

ASSEMBLY INSTRUCTIONS

Lift&slide hardware

System A, C, G, K

Timber



ONLY FOR
CERTIFIED SPECIALISTS!

Contents

Important information	3 - 4
Key	5
Application ranges	6
Calculation formulae for system A	7
Calculation formulae for system C	8
Calculation formulae for system G	9
Calculation formulae for system K	10
Sash height calculation formulae	11 - 12
Sash hardware overview	13
Frame hardware overview	14
Frame installation	15
Connecting plates drilling-hole pattern	15
Croppable connecting plates drilling-hole pattern	16
Screw fixing version 1	17 - 18
Screw fixing version 2	19 - 20
Overlap gasket and connection strip bottom	21
Overlap gasket and connection strip top	22
Frame assembly	23
Foamed rubber seals	24
Gasket tracks	25 - 27
Sash installation	28
Drilling and routing pattern for HS handles and drive gear	28
Drilling and milling jig for HS handle	29
Hook casing routing pattern	30
Roller installation 200 kg + 300 kg	31
Roller installation 400 kg	32
Roller installation for narrow casements	33 - 34
Drive gear assembly	35 - 36
Drive gear damper	37 - 38
Handle fitting	39
Sash gasket	40
Gasket tracks	41 - 44
Foamed rubber and overlap gasket strip system C	45
Sash and frame installation	46
Guide tracks and sash installation	46 - 47
Locking bolt	48
Locking bolt system C	49
Striker plate for hook gear system	50
Grease hook drive gear	51
Striker plate for hook gear system C	52
Installation of accessories	53
Standard buffer stop	53
Guide and roller track buffer stop	54
Locking block	55
Low threshold tread board walkway area	56
Fixed sash low threshold tread board	57 - 58



Important information

Target group

This documentation is intended exclusively for specialist companies and certified specialists. The work described may only be carried out by specialist personnel.

Instructions for use and safety

Assemble all hardware parts professionally as described in this manual and observe all safety instructions.

Overloading or improper operation of the lift and slide hardware may cause the sash to jump out of its guide, fall out and cause serious injury. If overloading of the lift and slide hardware is expected under special circumstances, such as in Schools, Kindergartens etc., this must be prevented using the appropriate measures,

e.g.

- Adjustment of the buffer stop to reduce the opening width, or
- Installation of a profile cylinder to prevent improper use.

Please observe the terms of our functional warranty (<https://www.maco.eu/assets/757752>) as well as the conditions of our surface warranty for MACO TRICOAT-PLUS hardware (<https://www.maco.eu/assets/757779>).

Observe the “Guidelines and Instructions on Product and Liability (GIPL)” of the Quality Association of Locks and Hardware. This policy describes all safety-related issues for end-users for window and balcony door topics. (Download available on the website of the Quality Association of Locks and Hardware).

For MACO lift and slide hardware HS, the application ranges given on page 6 must not be exceeded. In addition, specifications for the lift and slide door hardware, in particular on possible restrictions on sash dimensions and sash weight, must be strictly adhered to.

Assemble the complete hardware only from MACO hardware parts and the required accessories.

When using Accoya (registered trademark of Titan Wood Limited) and acid-treated woods (e.g. Oak, Teak, Larch), use only the TRICOAT-PLUS fittings.

Use the specified screw sizes as specified in this guide.

Turn the screws straight (unless otherwise stated) and do not over-tighten, otherwise smooth operation of the hardware may be impaired.

Fix the screws of the supporting components (e.g. rollers, running rail and guide rail) in the reinforcement profile.

Around the rollers, ensure a positive transfer of the compressive forces onto the reinforcement profile!

With the spacer-block setting, observe the technical guideline No. 3 of the glazier trade “Blocking of glazing units”.

Do not use acid-curing sealants, as these can lead to corrosion of the hardware parts.



Keep the runner of the roller track, the threshold and all folds free of deposits and dirt, and in particular of cement or plaster residues. Avoid direct moisture on the hardware and contact of the hardware with acidic cleaning agents.

Attach the operating label in a clearly visible manner to the built-in lift and slide sash. The operating label can be found in the base carton.

Do not make any constructive changes to the hardware parts.

If you are not sure, please ask your MACO contact person for advice.

Certification

The MACO hardware mentioned in the assembly instructions are tested and regularly monitored in standardised tests in accordance with EN 13126. The achieved standards Class H3 does not refer to the individual element system. Due to a wide range of influencing factors, individual element systems may experience minor deviations from standardised testing, such as:

- the influence of processing tolerances
- the effect of assembly tolerances after the installation of the element in the building
- the use of accessories (e.g. weather seals, sealing rails, handles, etc.)
- the use of additional equipment (e.g. sliding damper, swing-check damper, operating force reduction, etc.) and/or attachments (e.g. Aluminium shells, sun protection on the sash, insect protection)
- external environmental influences (e.g. humidity, sunlight, high or low temperatures, temperature fluctuations, etc.) or
- room-side influences (moisture, aggressive cleaning agents, etc.)

Key



HS Lift&slide unit



FH Sash height



FB Sash width



RAB Frame outer width



RAH Frame outer height



L Total length



GM Handle height



DM Backset drive gear

Dimensions in [mm]: All dimensions without units are specified in [mm]

Application ranges

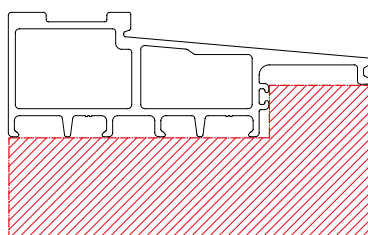
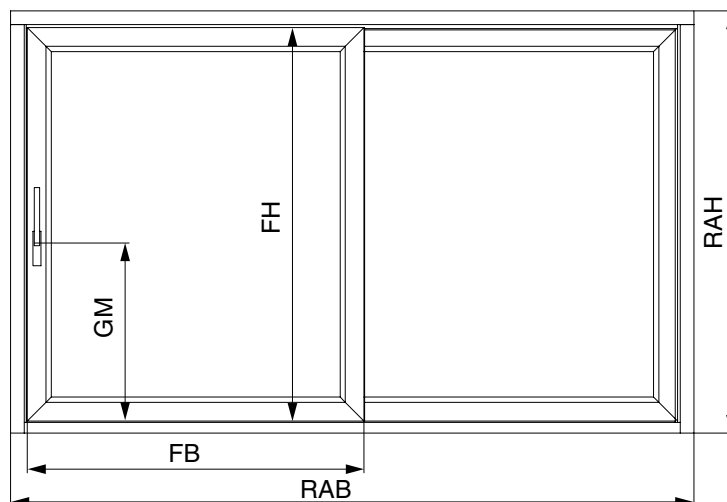

Warning!

GRP threshold must be lined so that it is pressure resistant!



Statics warning!

The window manufacturer is responsible for the static dimensioning as well as the lining of the GRP threshold based on the profile design and the wood type!

Code	Designation	Unit	150 kg	300 kg	400 kg
FB	Sash width	[mm]	630 - 2200	720 - 3385	1200 - 3385
FH	Sash height	[mm]	745 - 2860*		
FB : FH	Sash ratio	-	1 : 2,5 max.		
DM	Backset	[mm]	27.5 / 37.5		
GM	Handle height (drive gear size 1-2)	Tall roller track	[mm]	410	
		Flat roller track	[mm]	400	
	Handle height (drive gear size 3-5)	Tall roller track	[mm]	1010	
		Flat roller track	[mm]	1000	

* in special cases up to 3860 mm is possible

Calculation formulae for system A

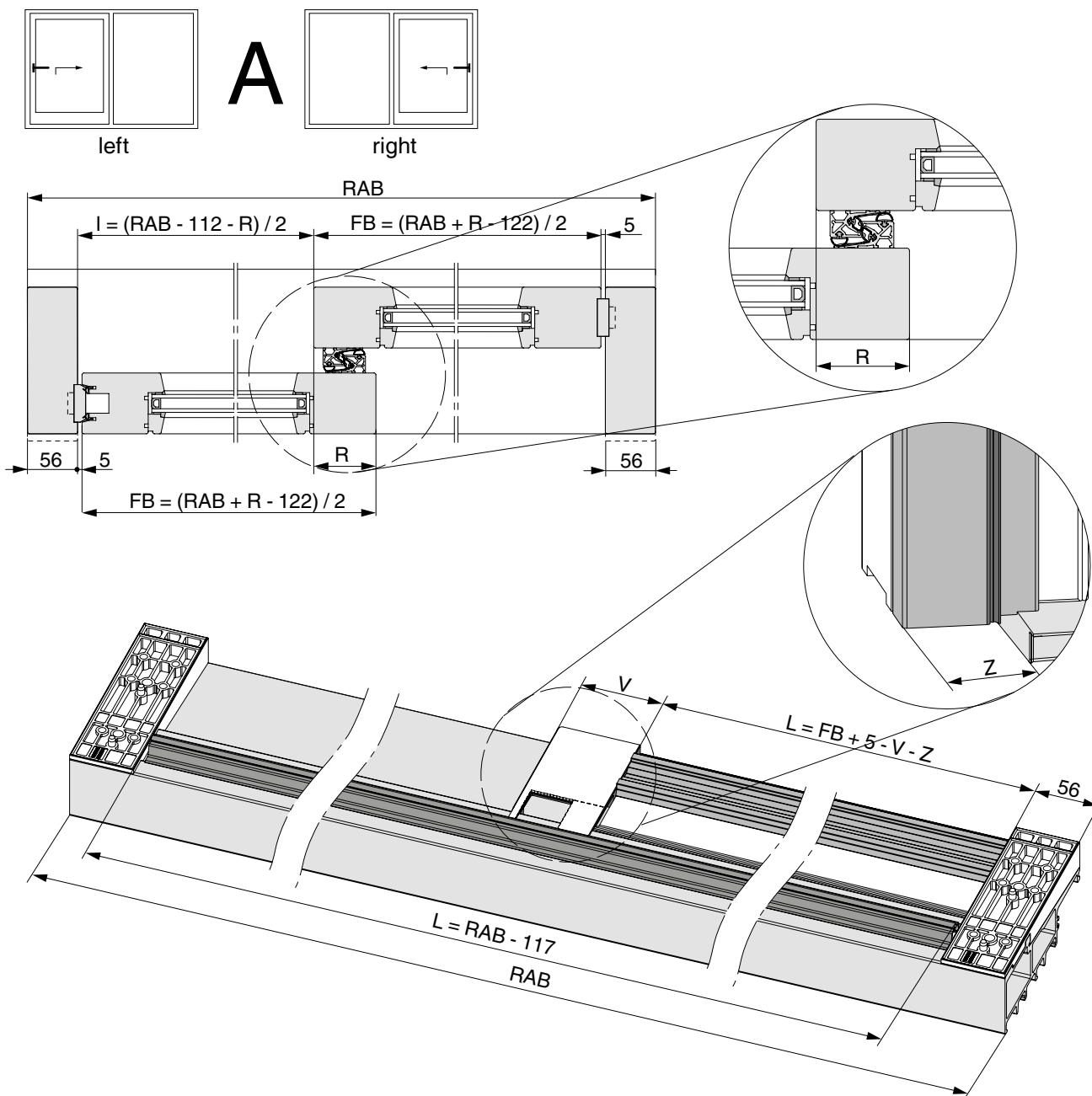

$V = 88,5$	$V = 65$
$Z = 0$	$Z = 34$

Calculation formulae for system C

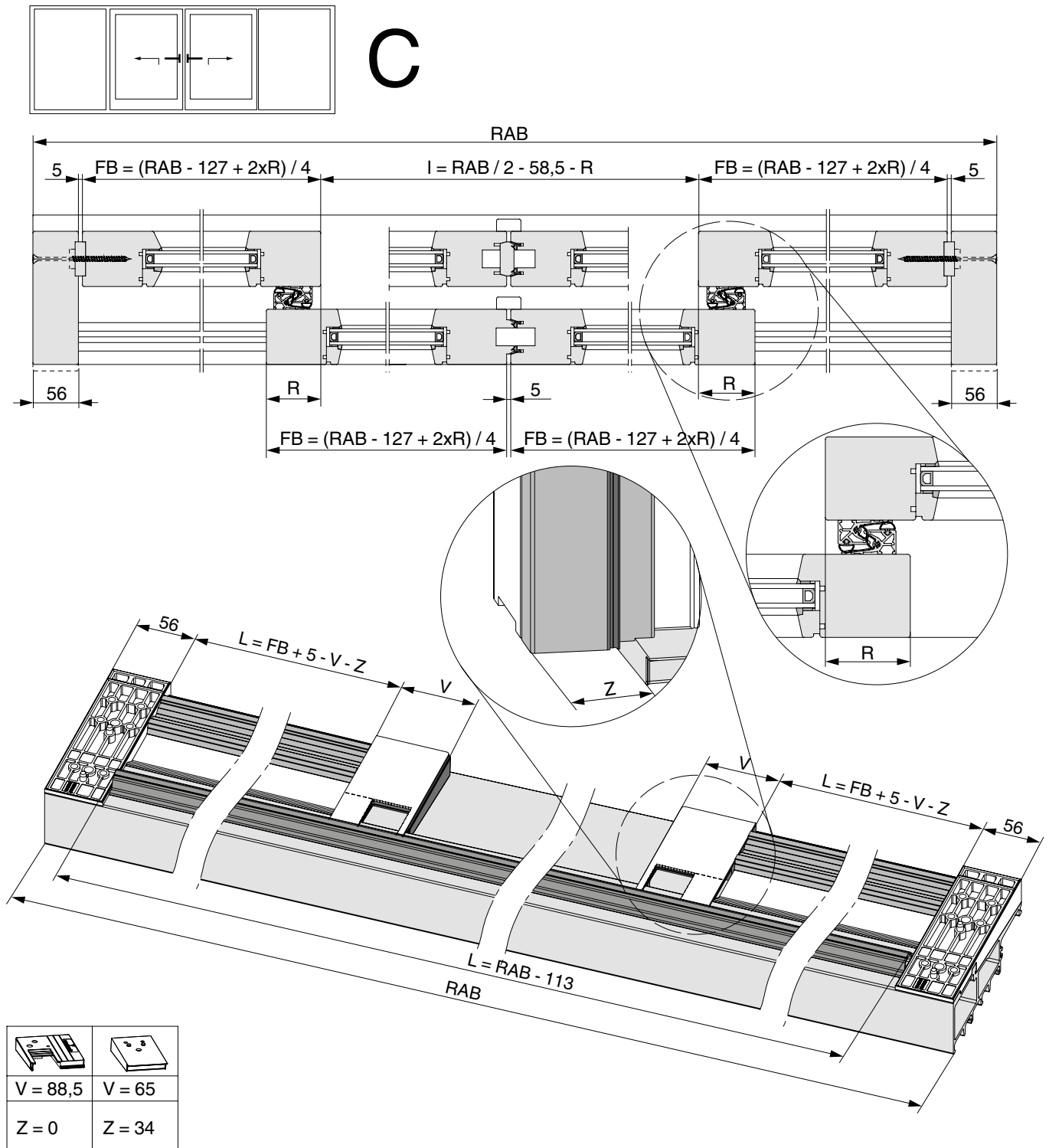

Calculation formulae for system G

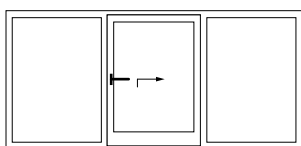

G

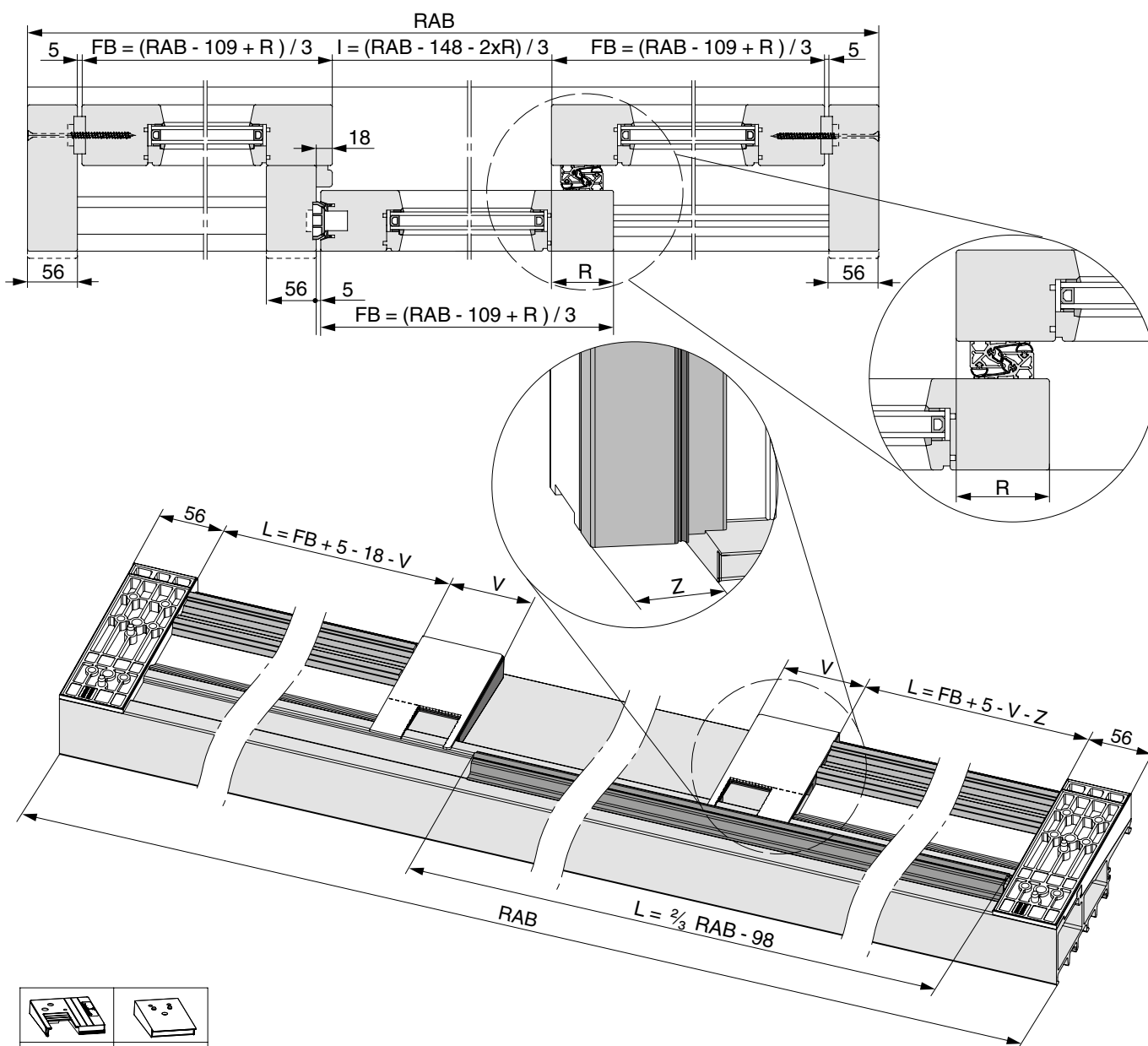

V = 88,5	V = 65
Z = 0	Z = 34

Calculation formulae for system K



K

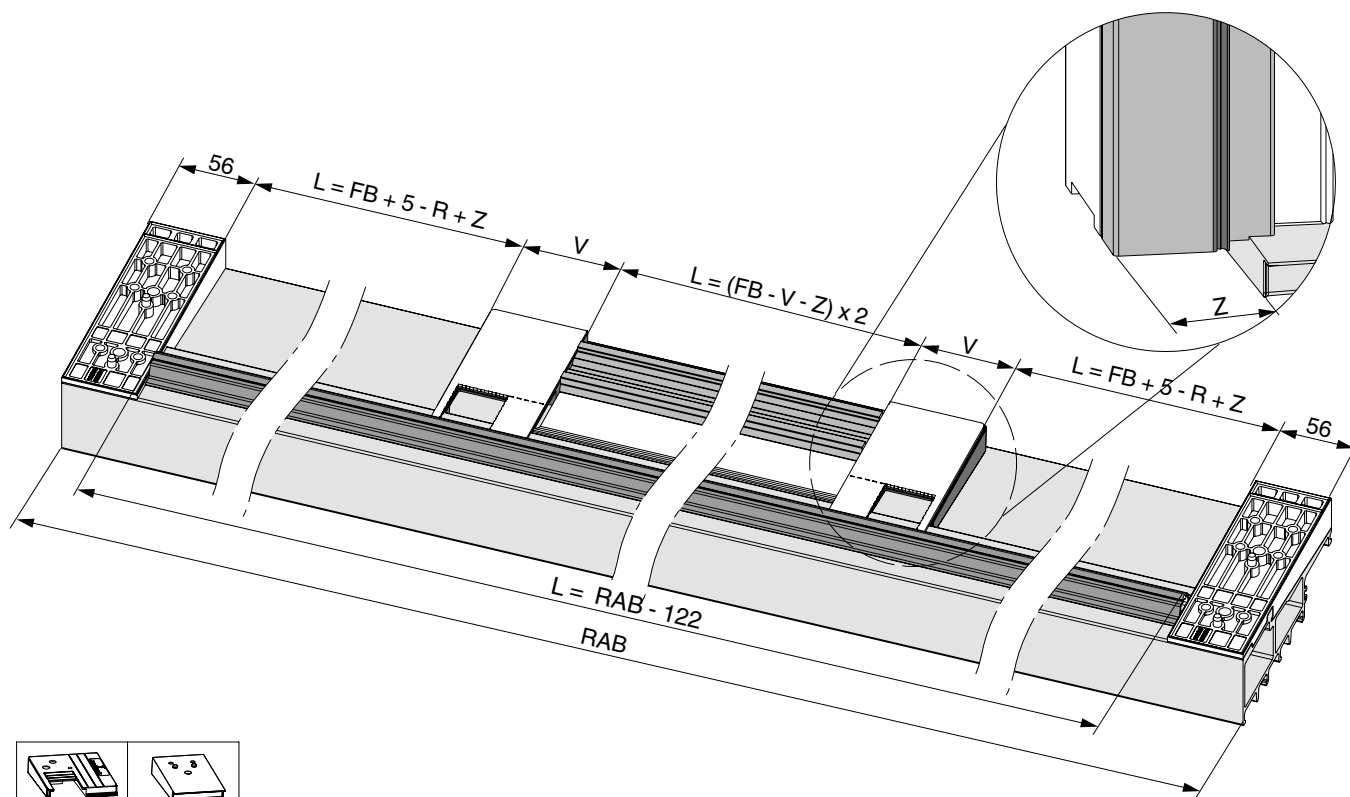
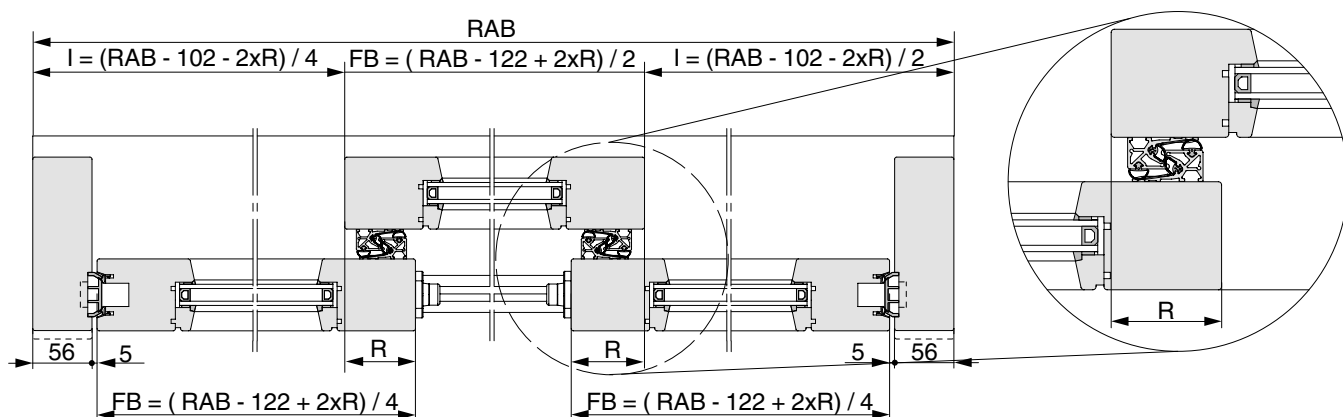





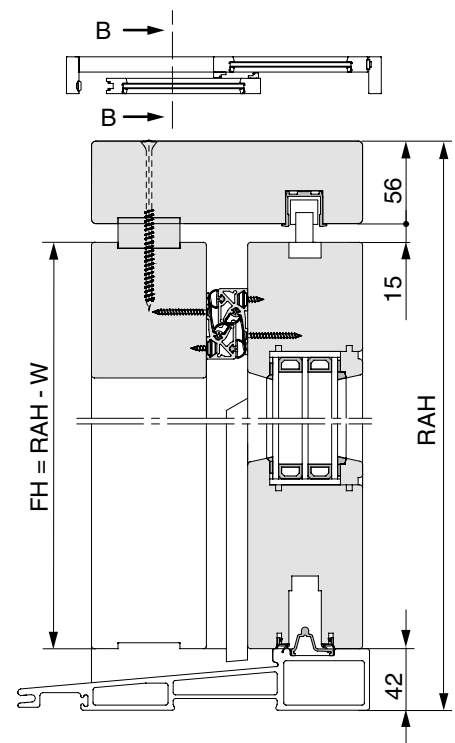
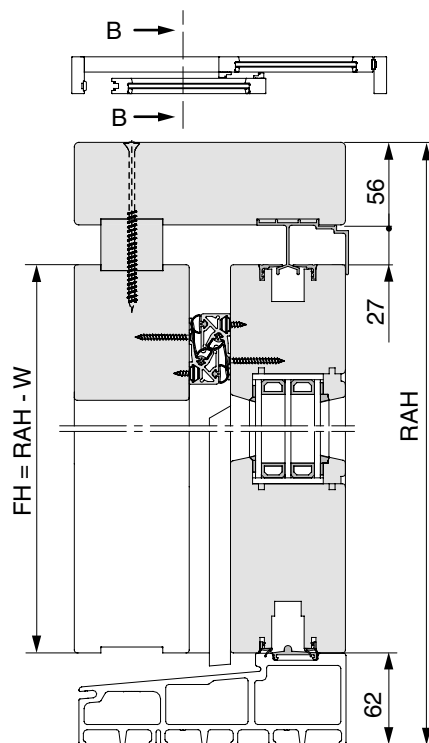
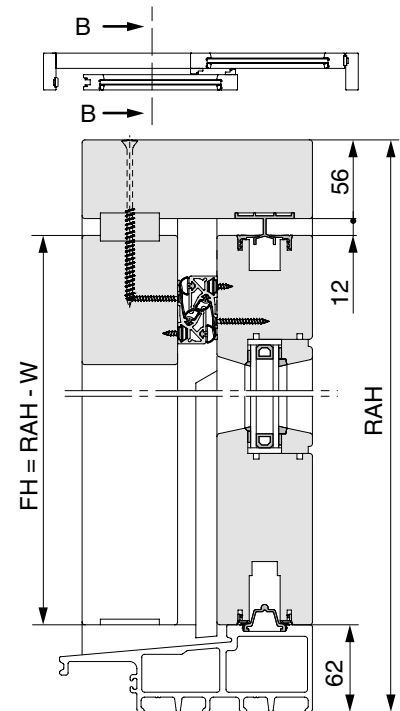
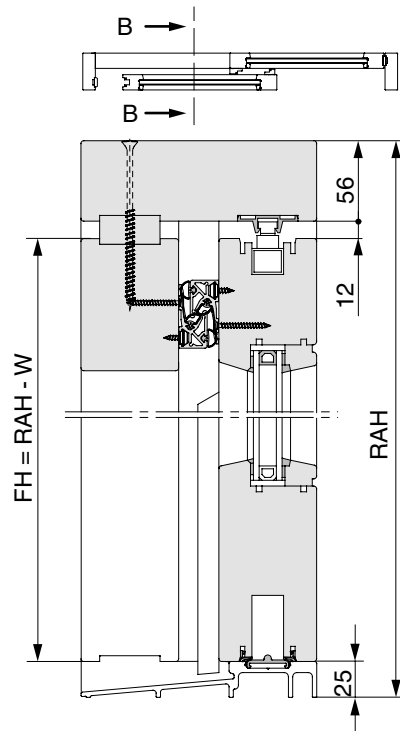



$V = 88,5$	$V = 65$
$Z = 0$	$Z = 34$

Sash height calculation formulae

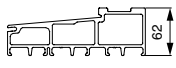
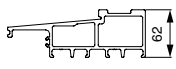

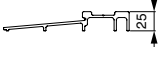
Sash height calculation formulae

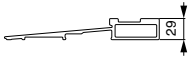
W				
 	130	130	145	133
 	93	93	108	96
	110	110	125	113
	97	97	112	100

Sash hardware overview

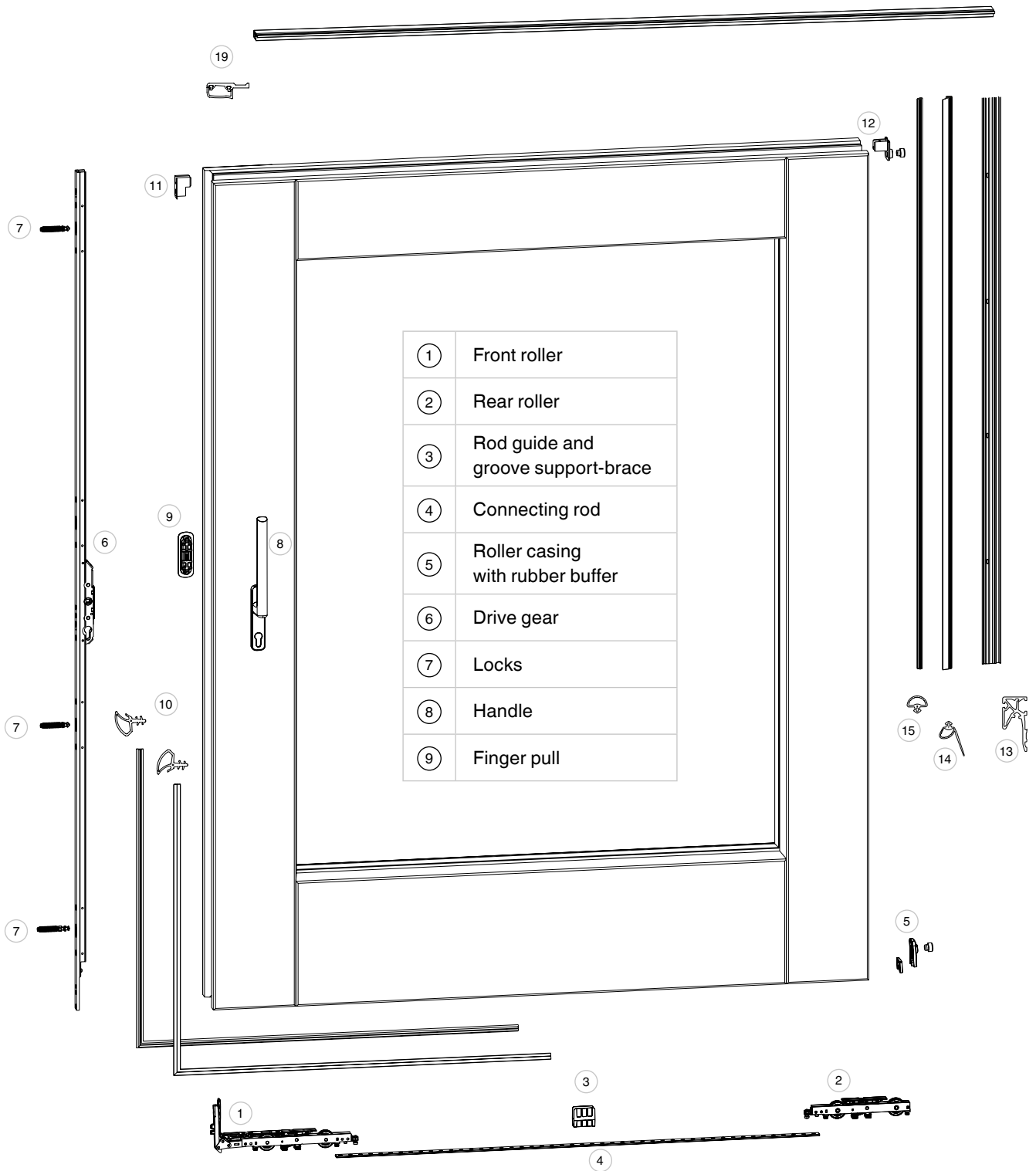

Frame hardware overview

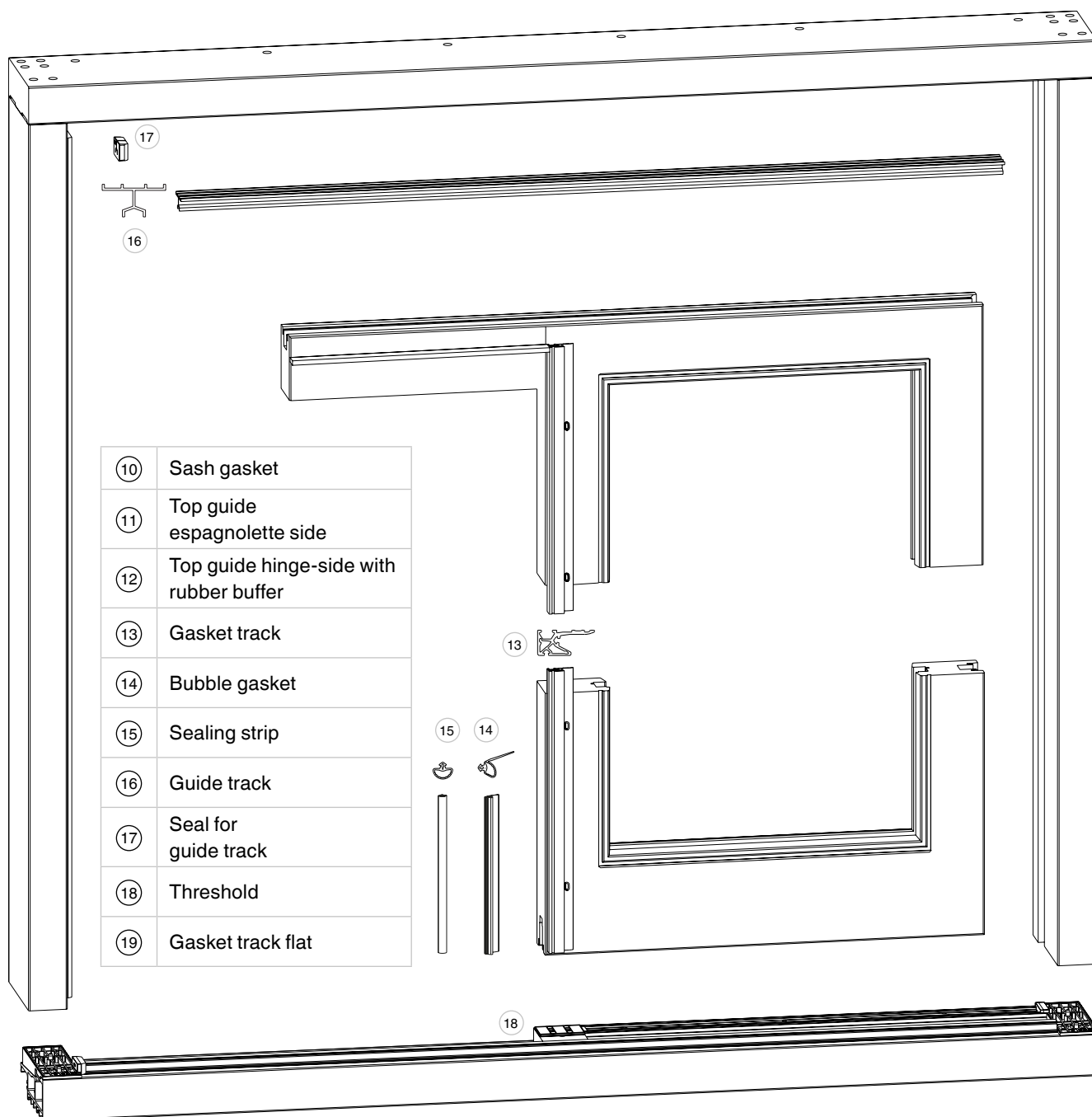

Frame installation

Connecting plates drilling-hole pattern

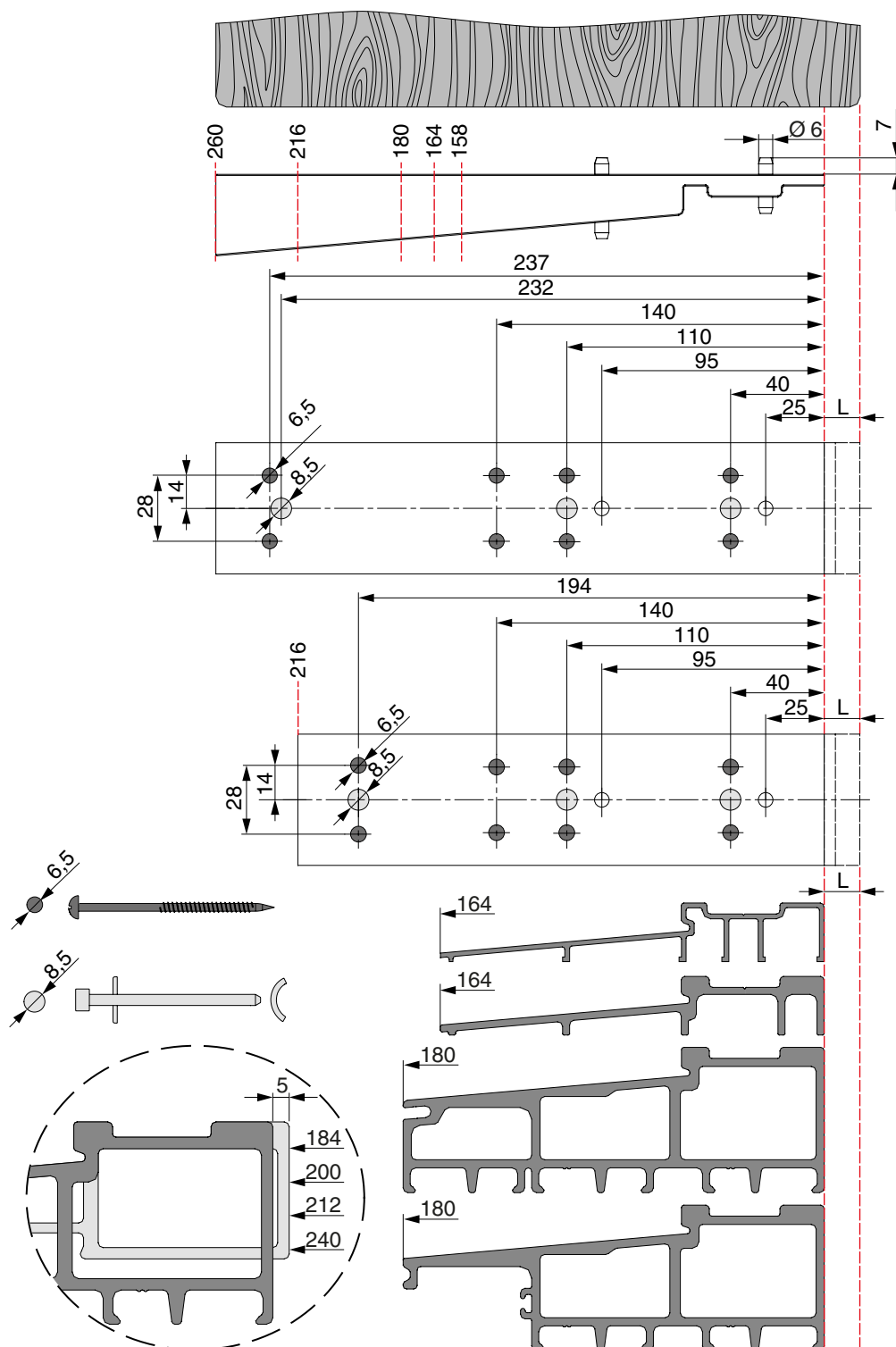

Frame installation

Croppable connecting plates drilling-hole pattern

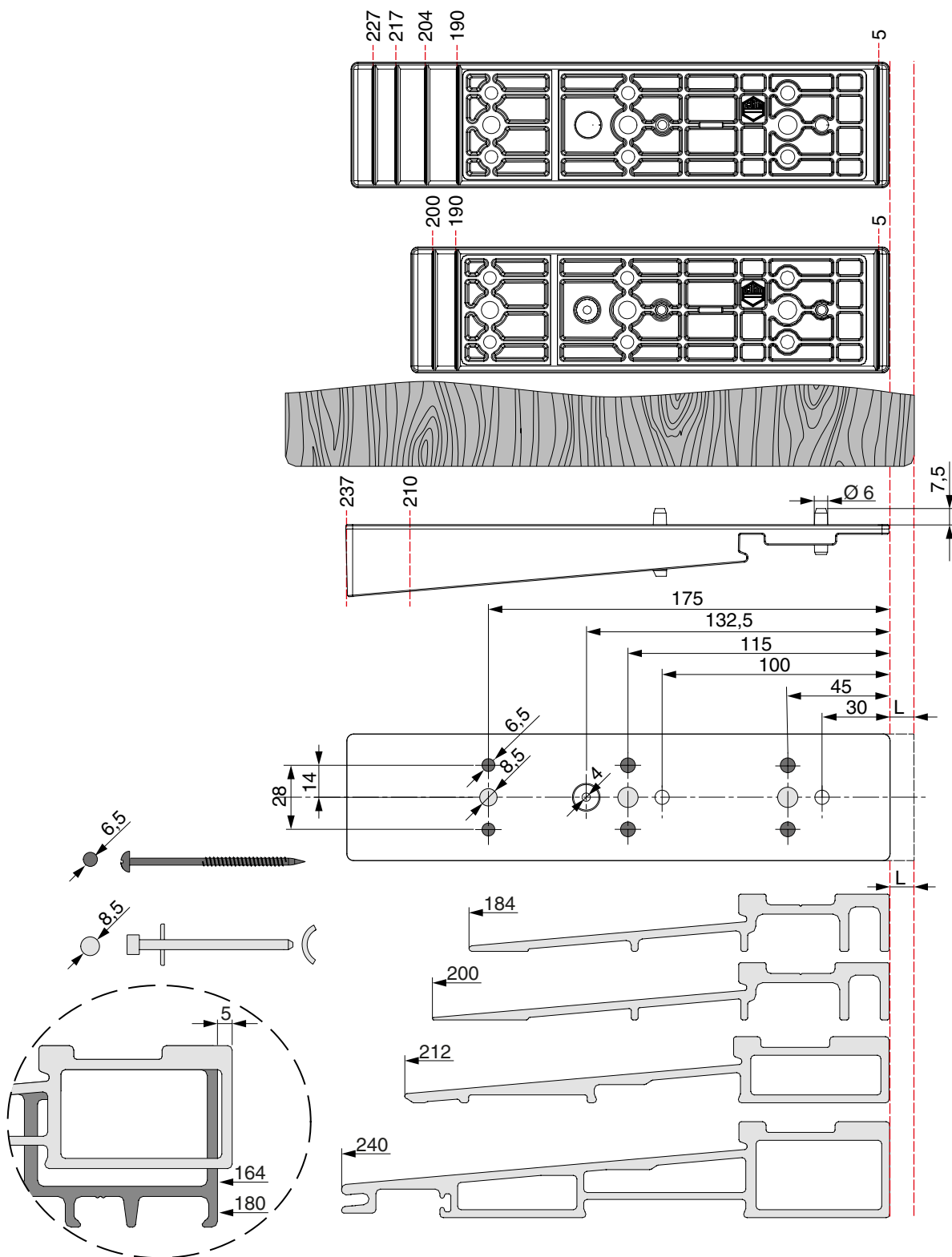

Frame installation

Screw fixing version 1

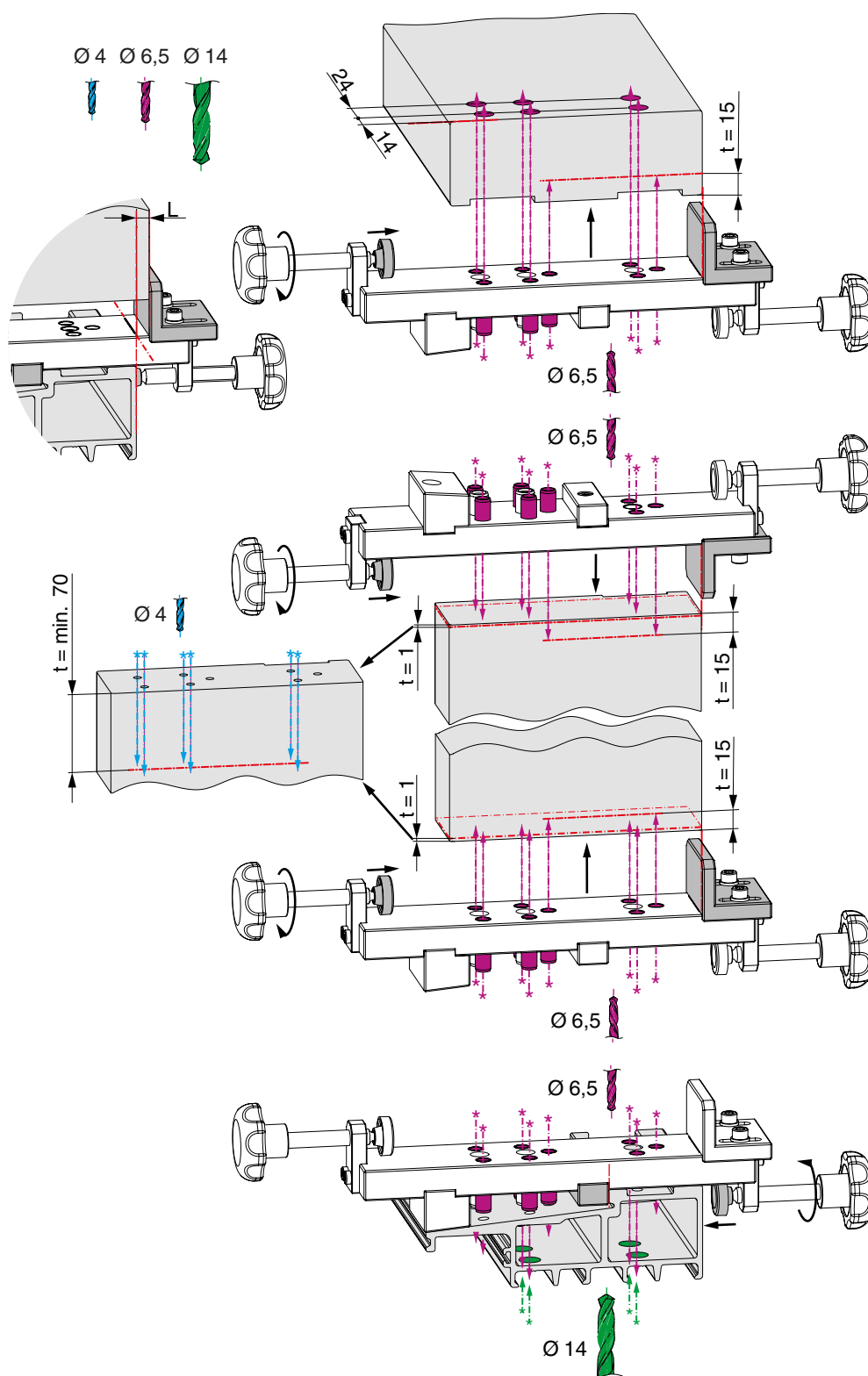

Ø 6 x 120

Ø 6 x 100

Ø 6,8 x 30

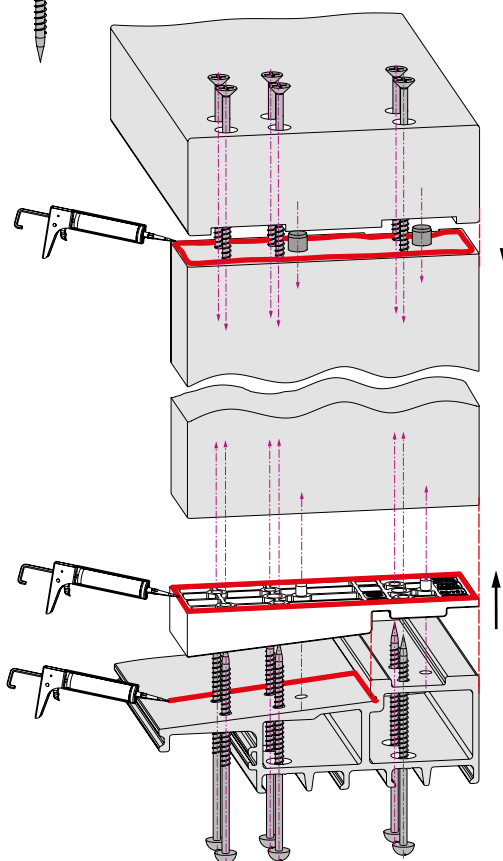
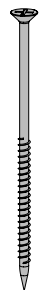

Frame installation

Screw fixing version 2

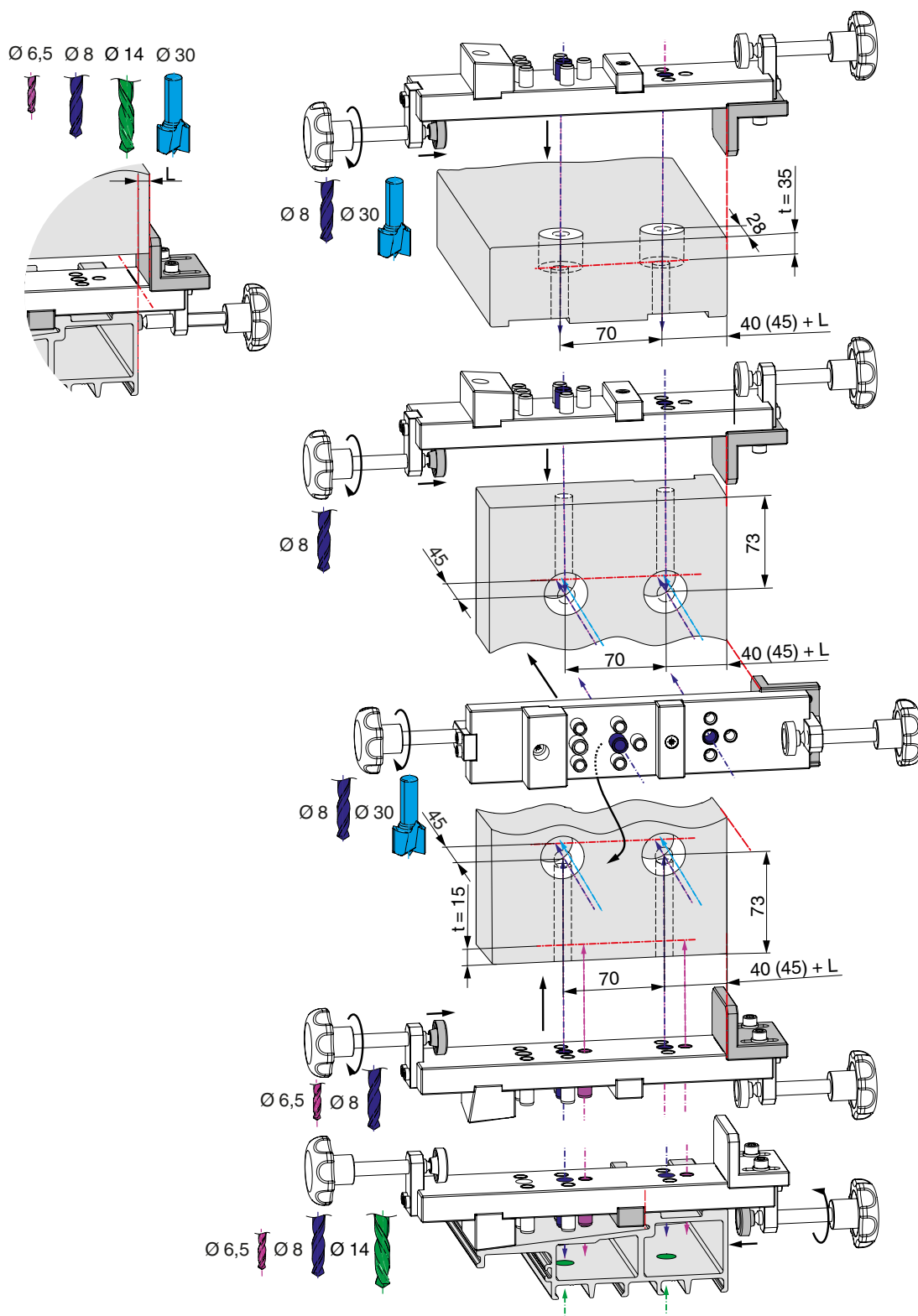

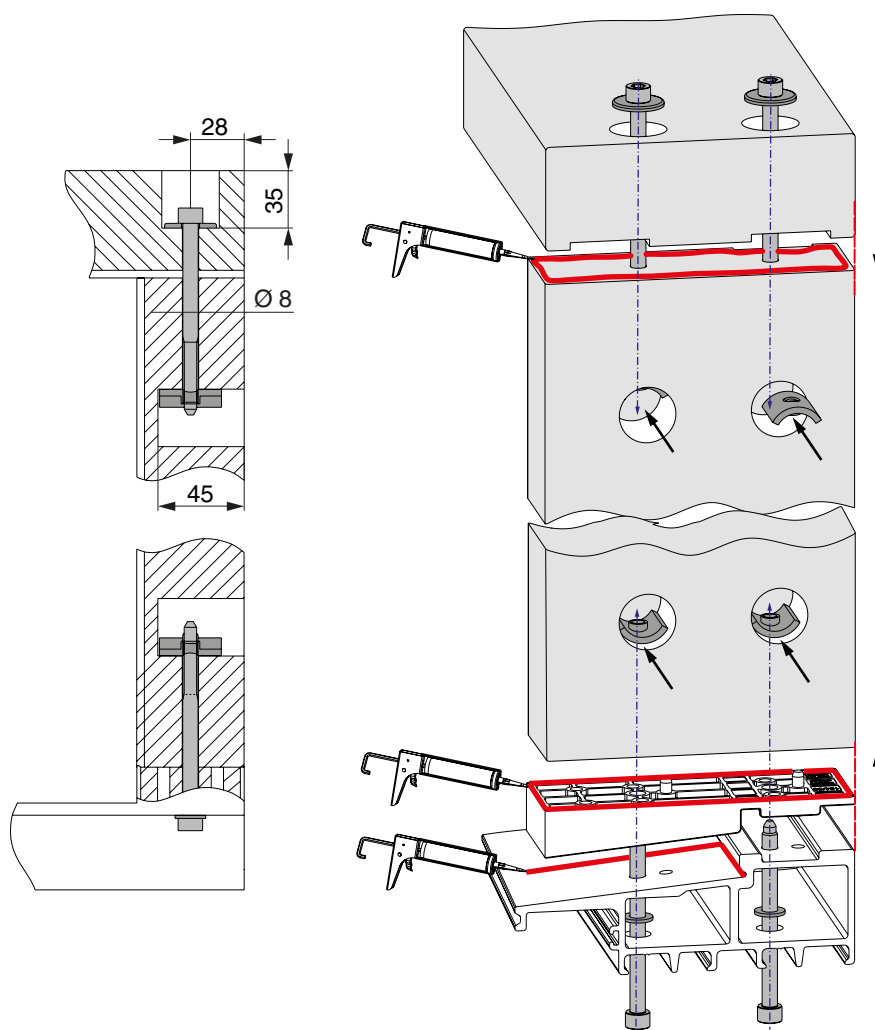

Frame installation

Overlap gasket and connection strips, bottom

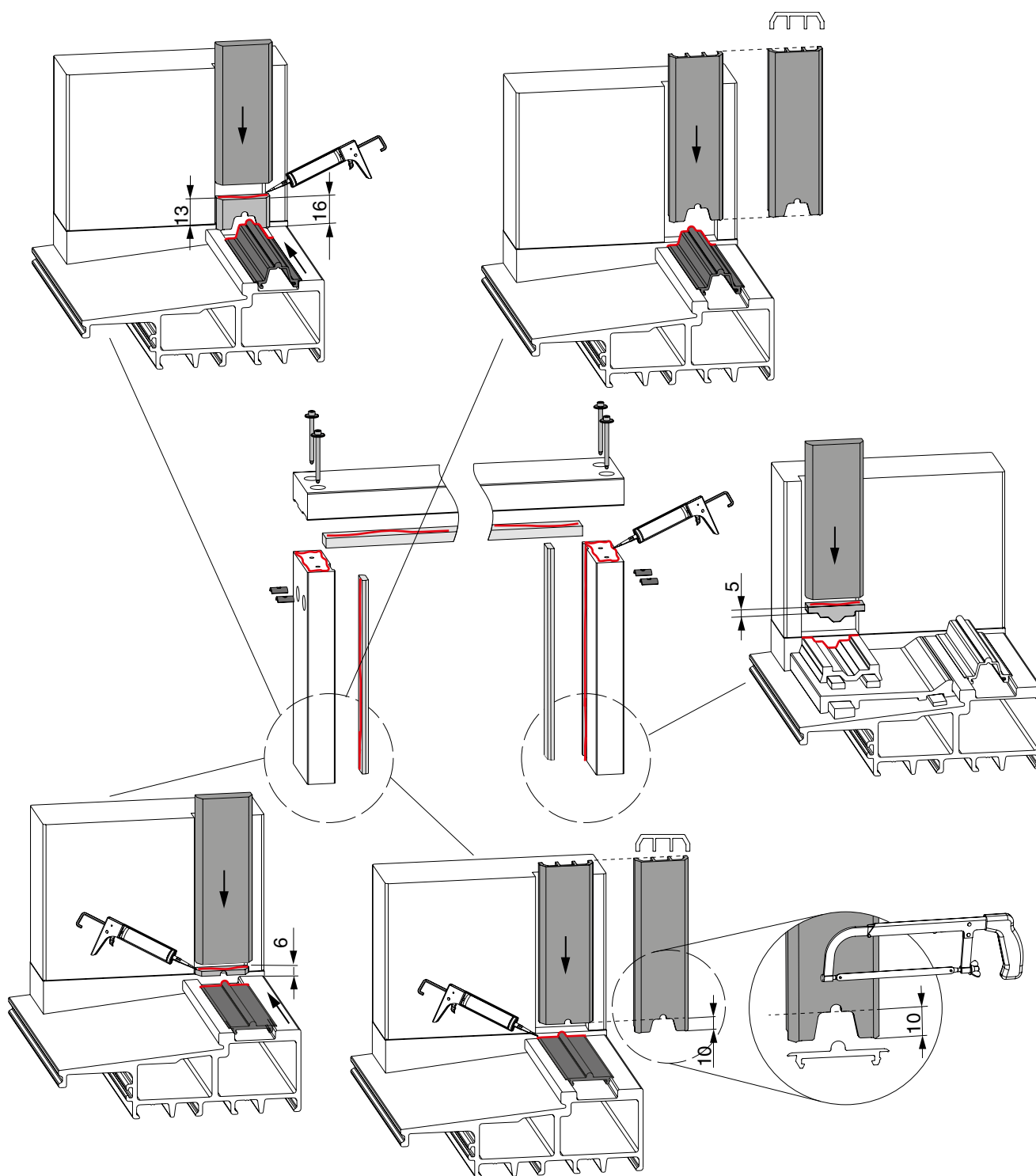

Frame installation

Overlap gasket and connection strips, top

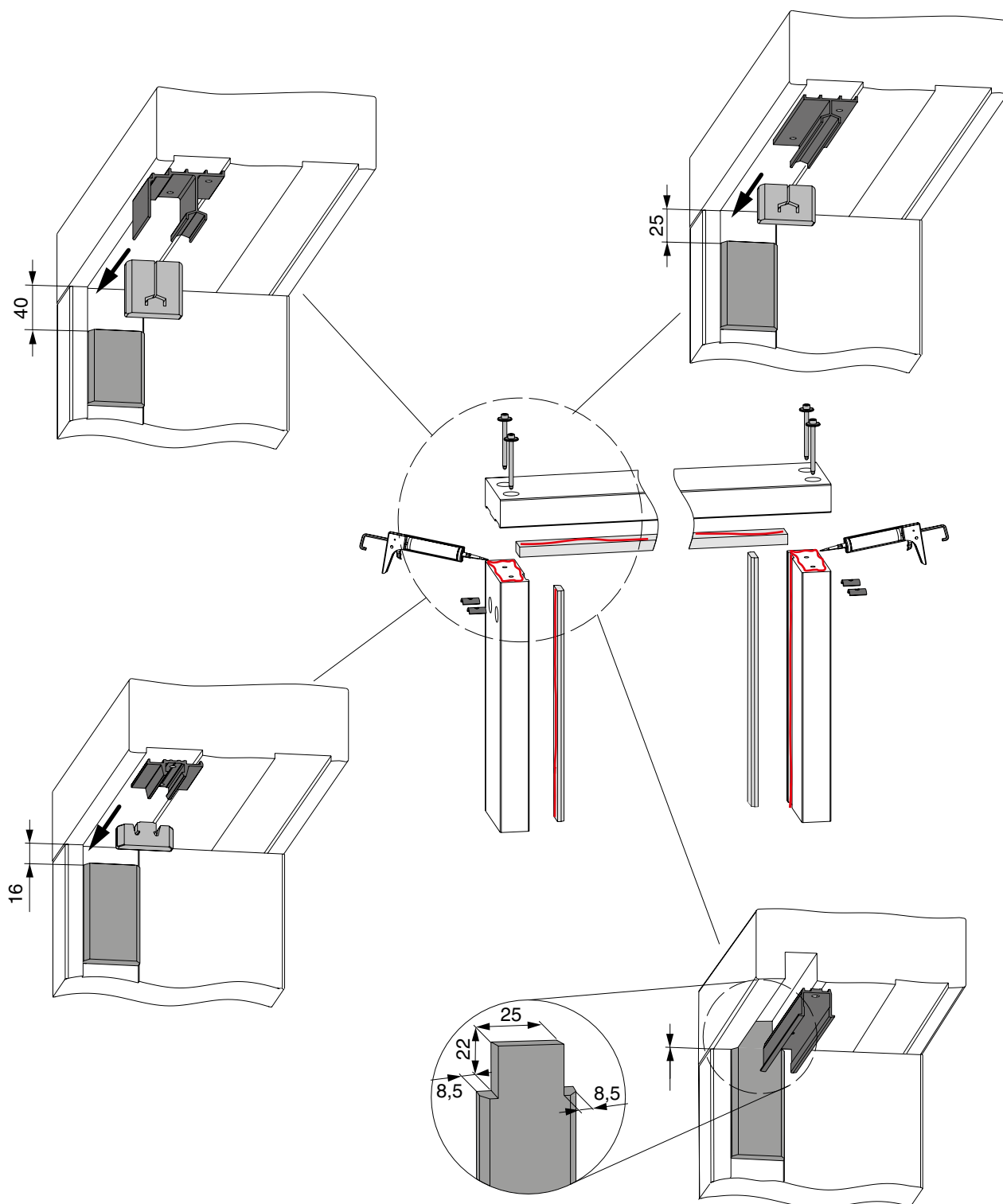

Frame installation

Frame assembly

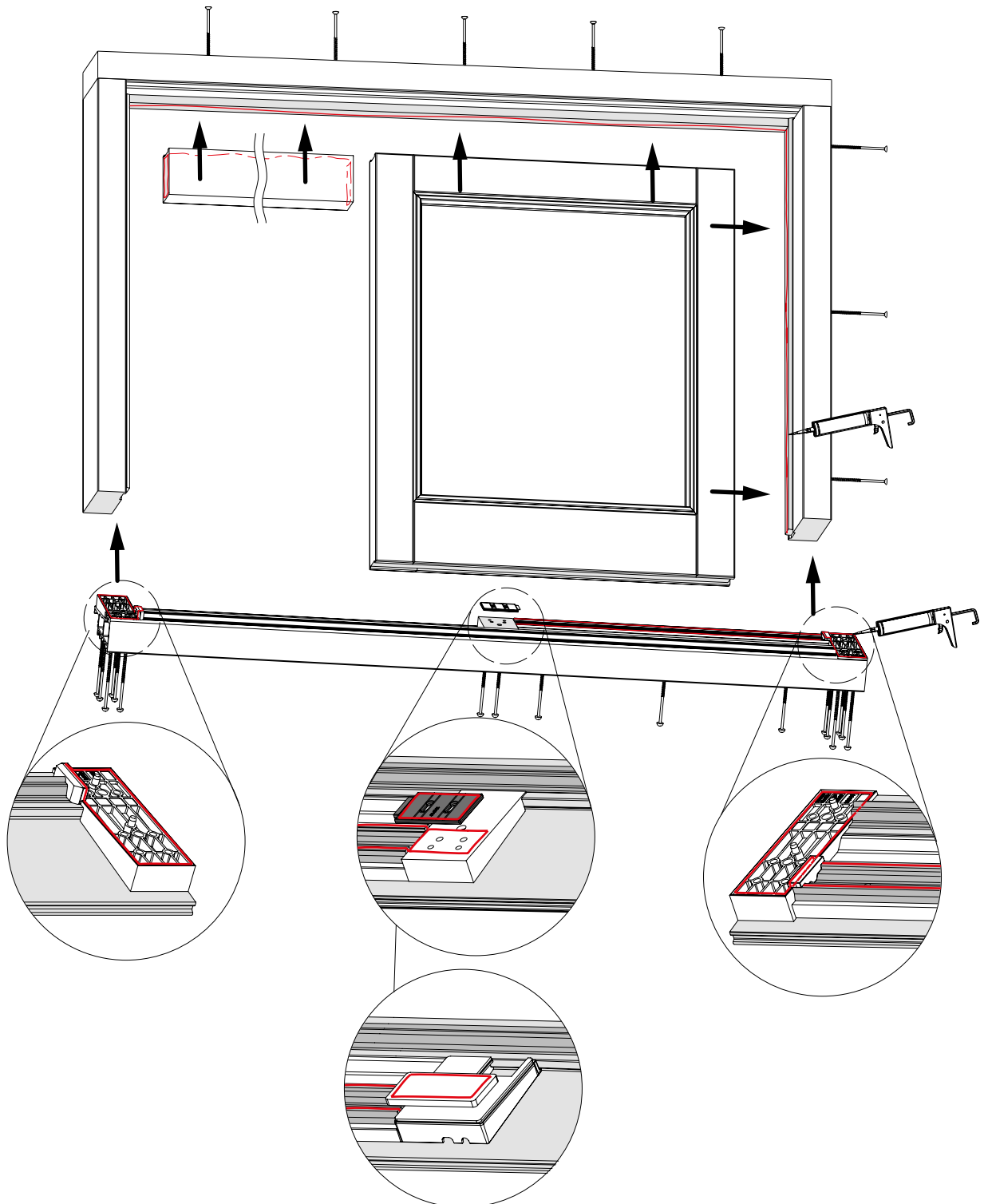

Frame installation

Rubber seals

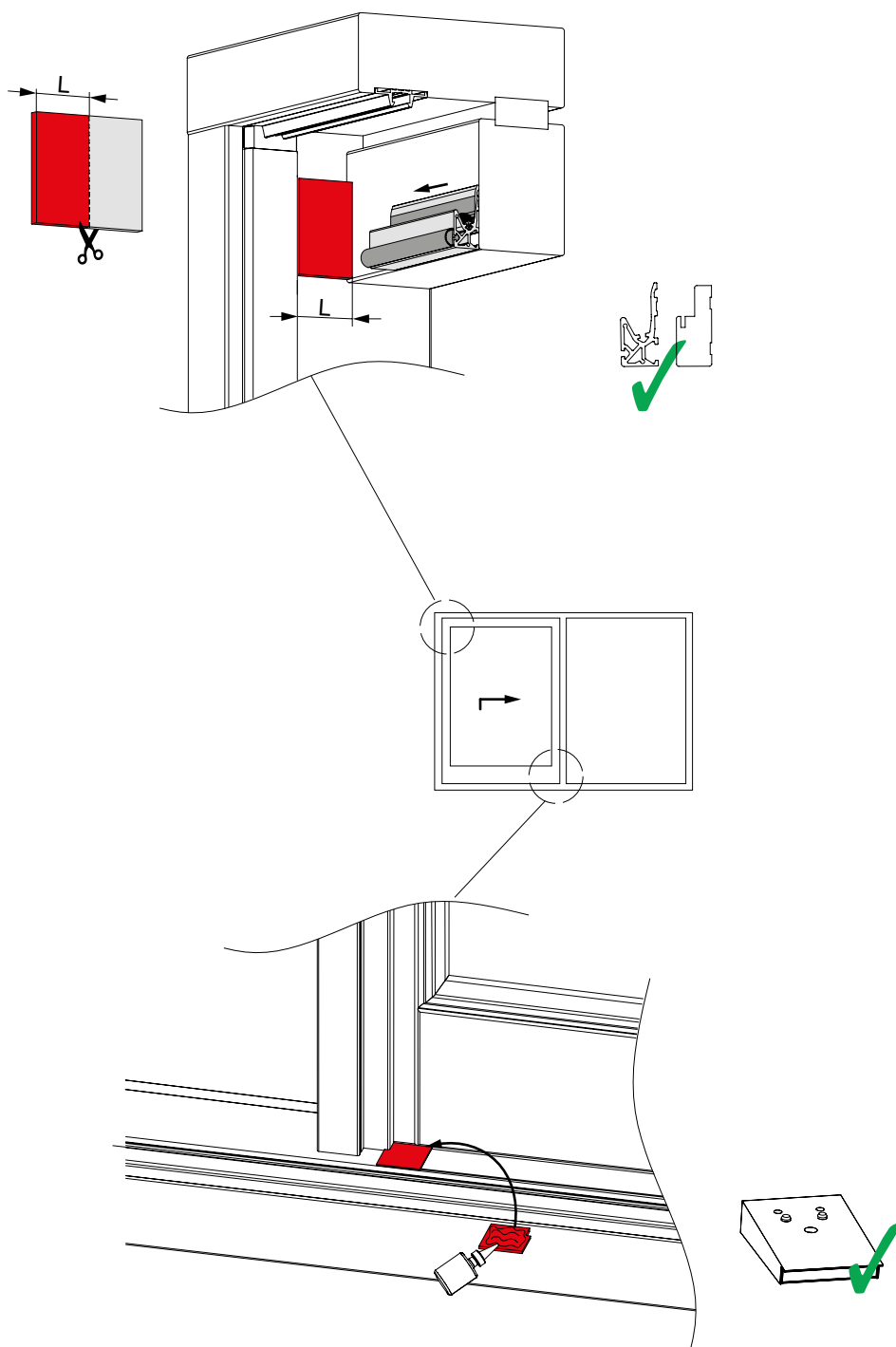

Frame installation

Gasket tracks

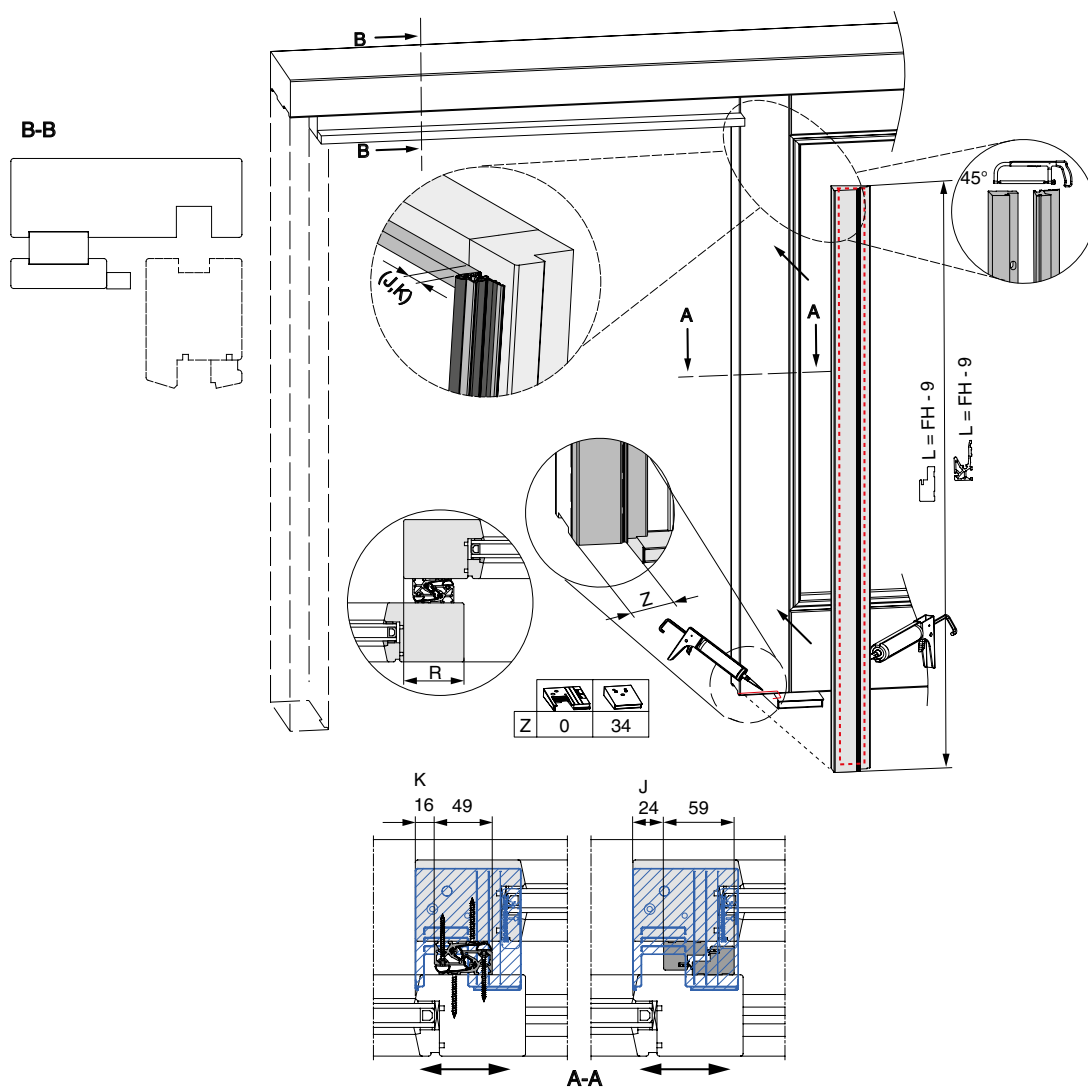

Frame installation

Gasket tracks



Timber

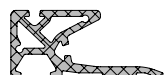
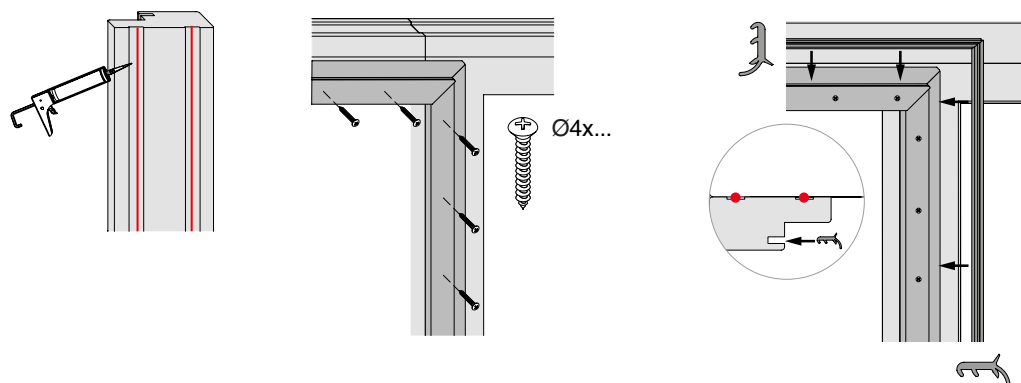

PVC

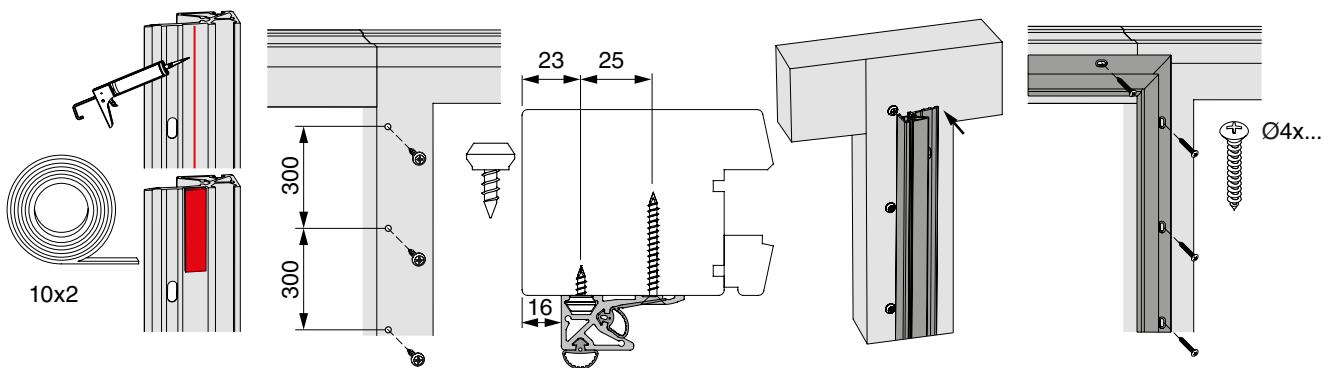
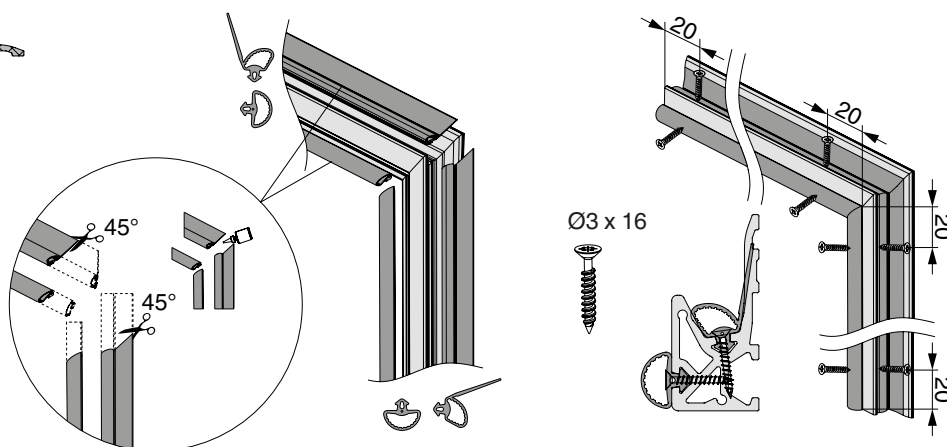

Sash installation

Drilling and routing pattern for HS handles and drive gear

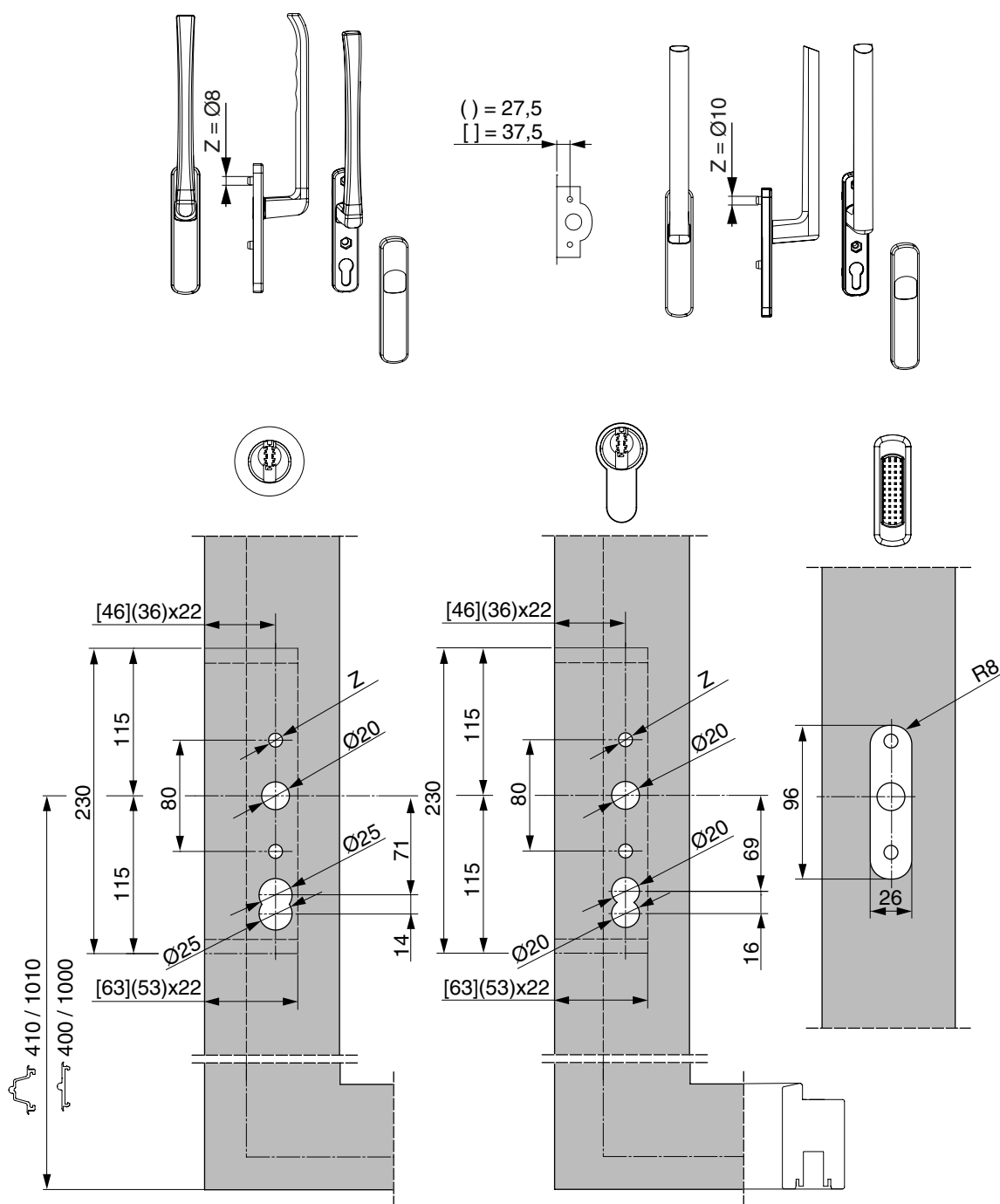

Sash installation

Drilling and milling jig for HS handle

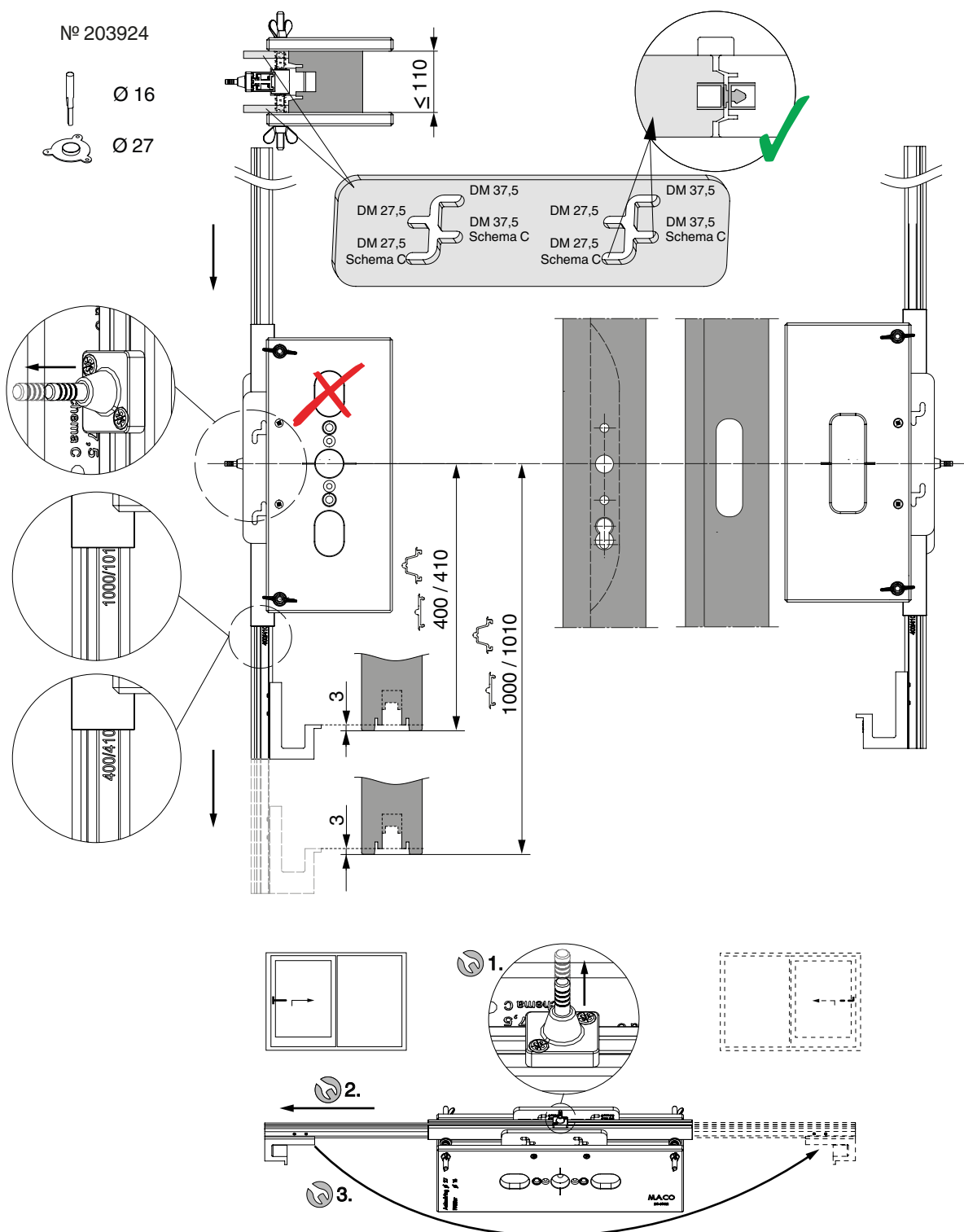

Sash installation

Hook casing routing pattern

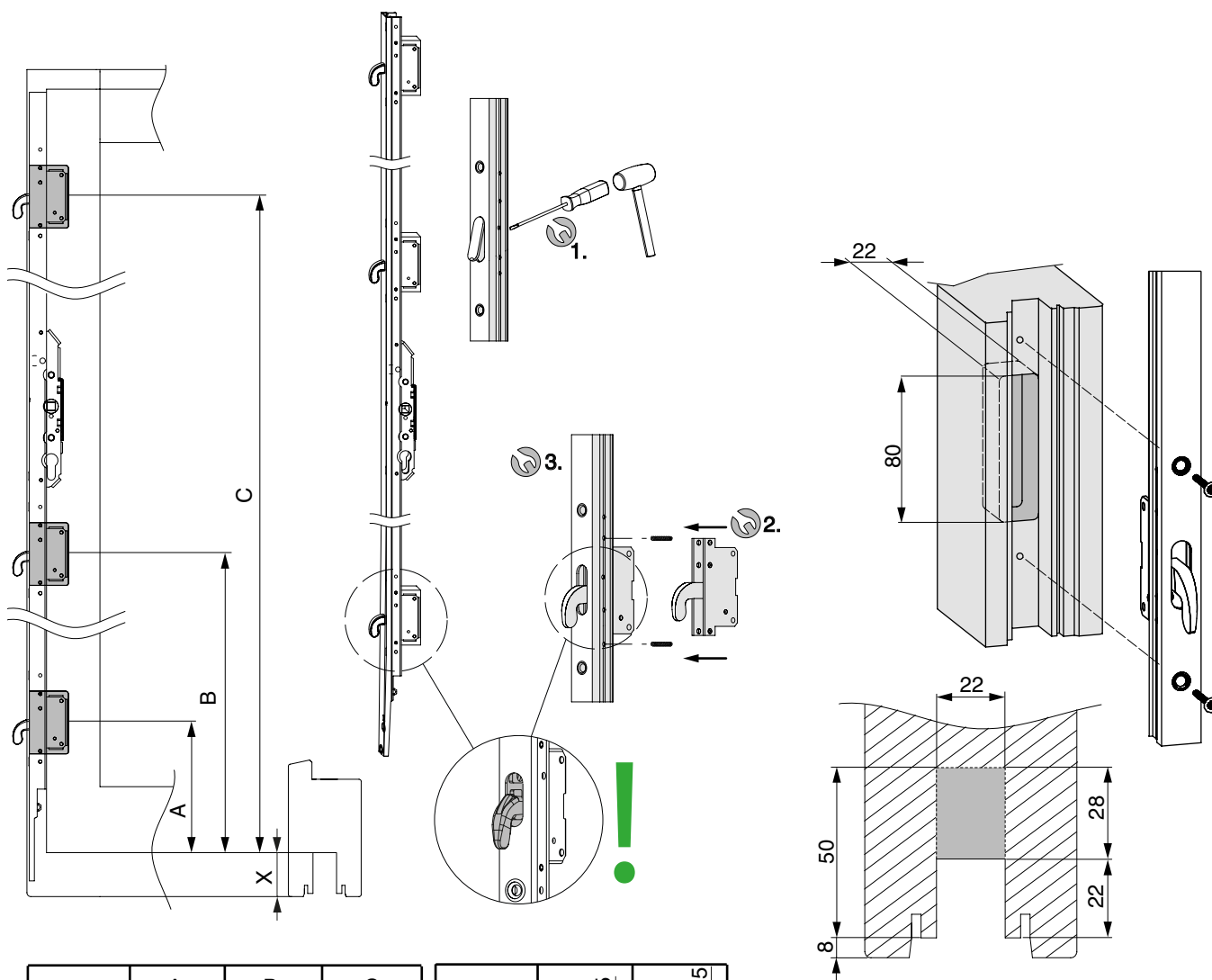

	A	B	C
Gr. 1	166	536	-
Gr. 2-3	166	1036	-
Gr. 4	166	754	1634
Gr. 5	166	1166	2066
Gr. 6	166	1366	2466
Gr. 7	166	1366	2466

X	5	15
200 kg	35	45
300 kg	46	56

Sash installation

Roller installation 200 kg + 300 kg

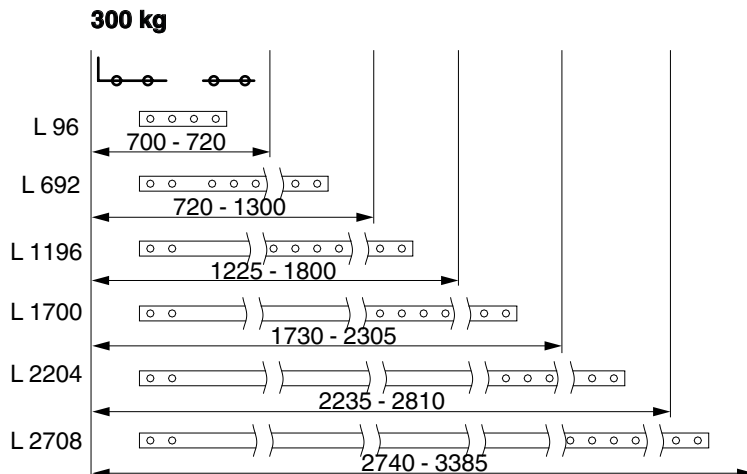
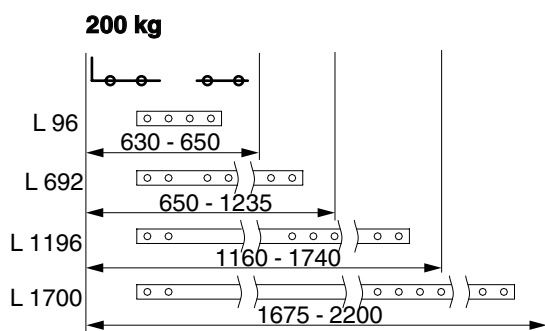
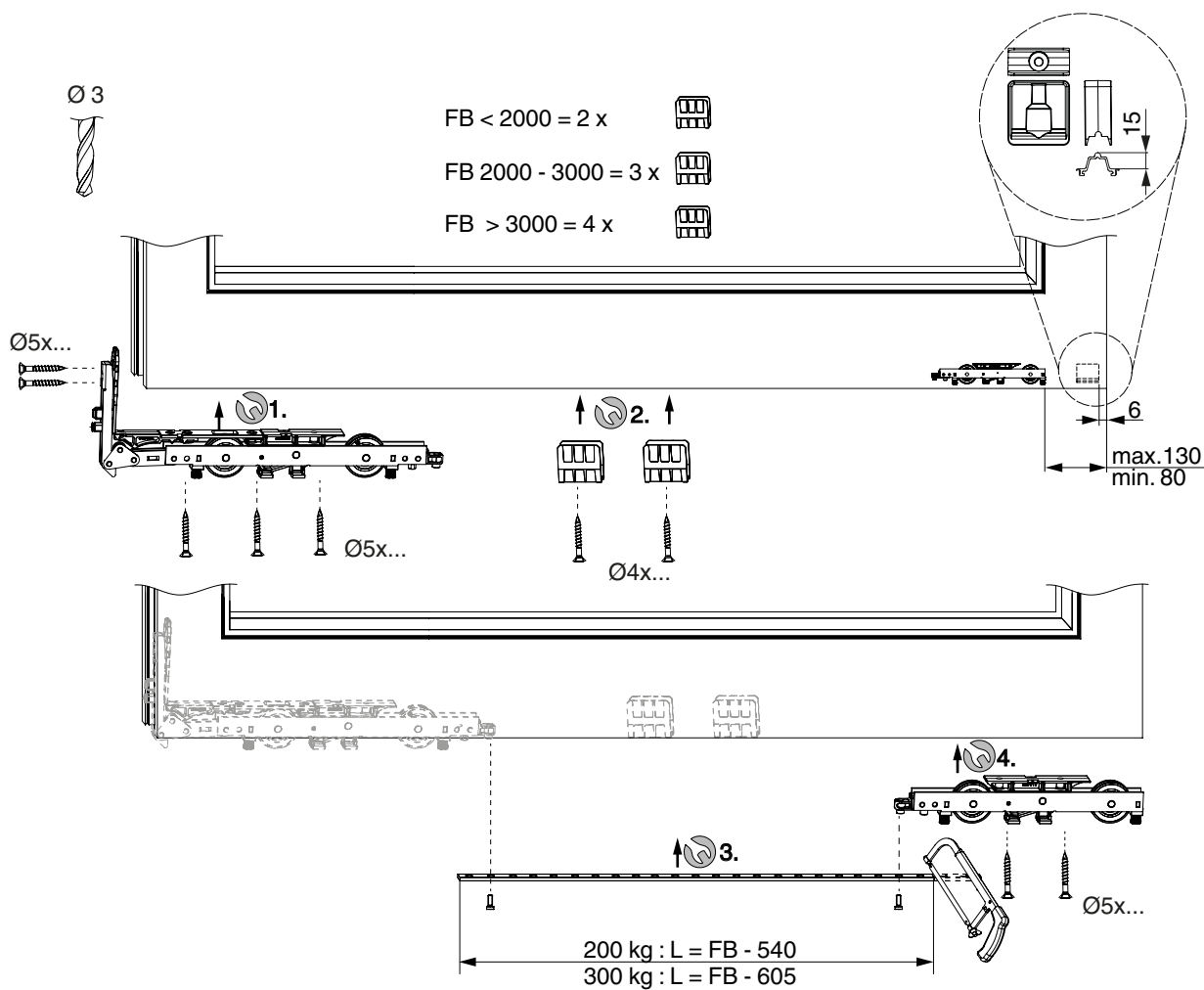

Sash installation

Roller installation 400 kg

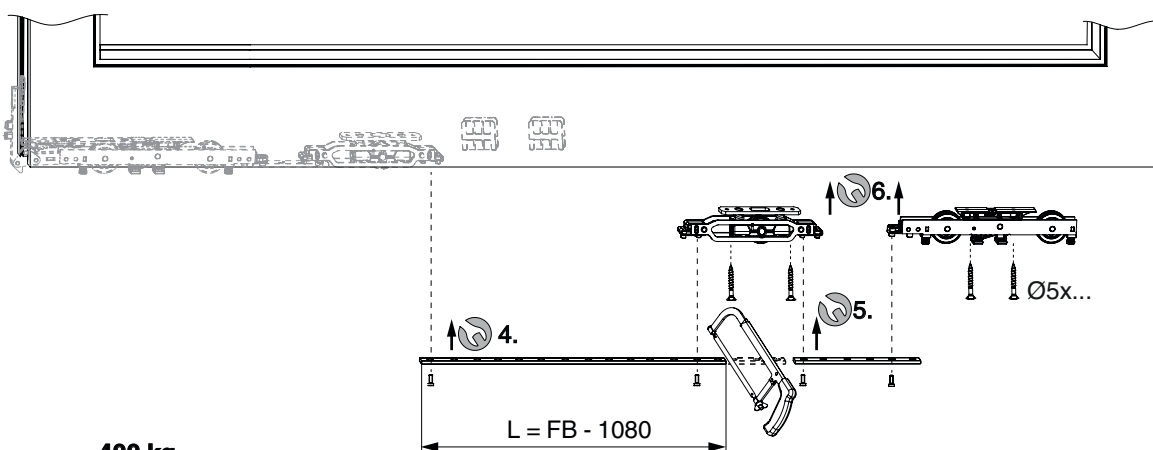
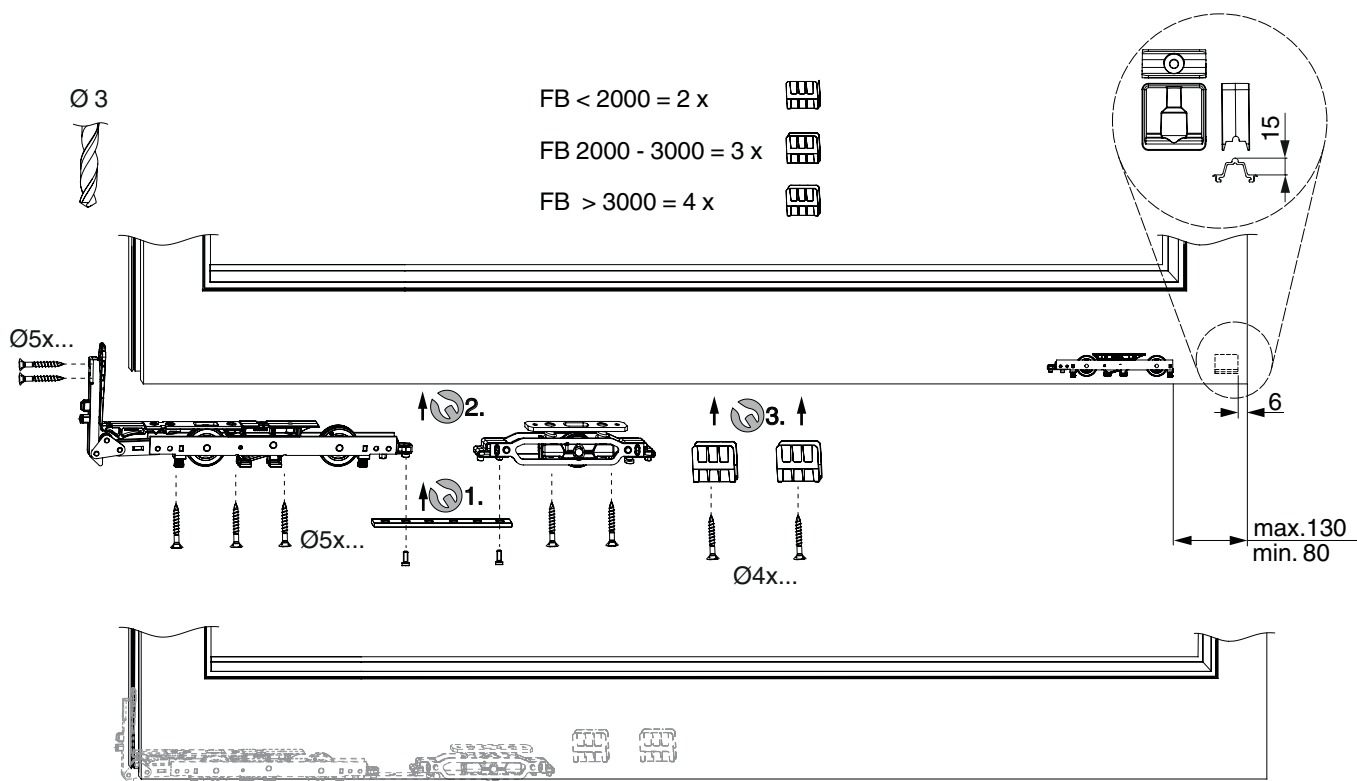

400 kg

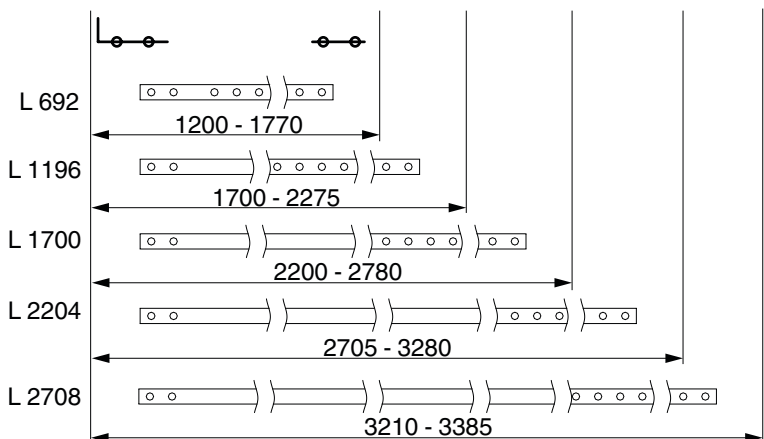

Sash installation

Roller installation for narrow casements

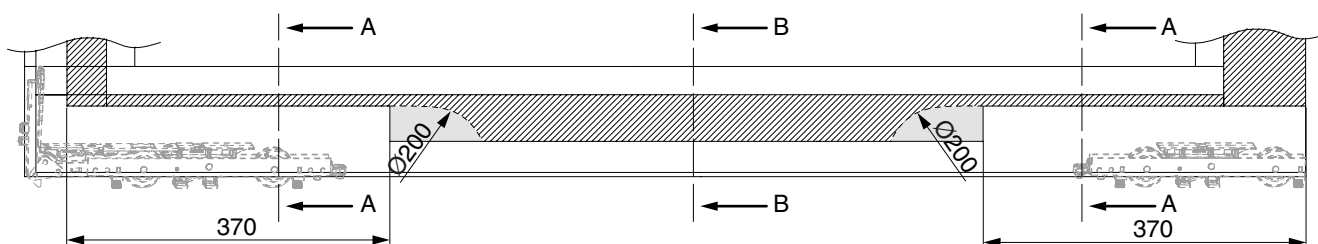

≤ 300

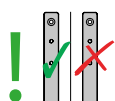

8 - 22
≥ 22

A-A

B-B

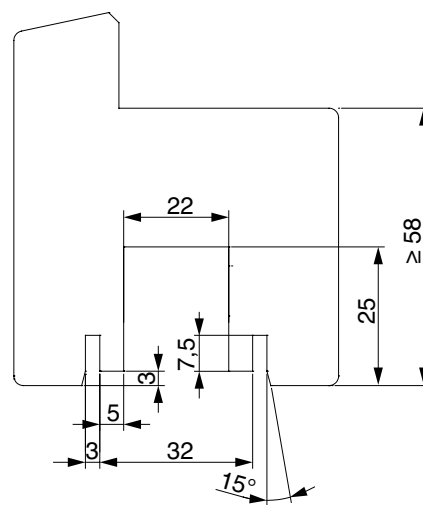
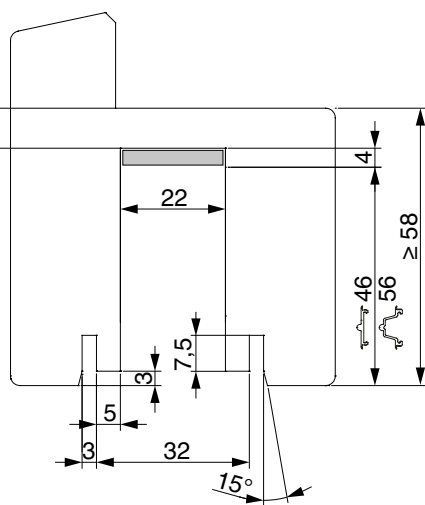

Sash installation

Roller installation for narrow casements

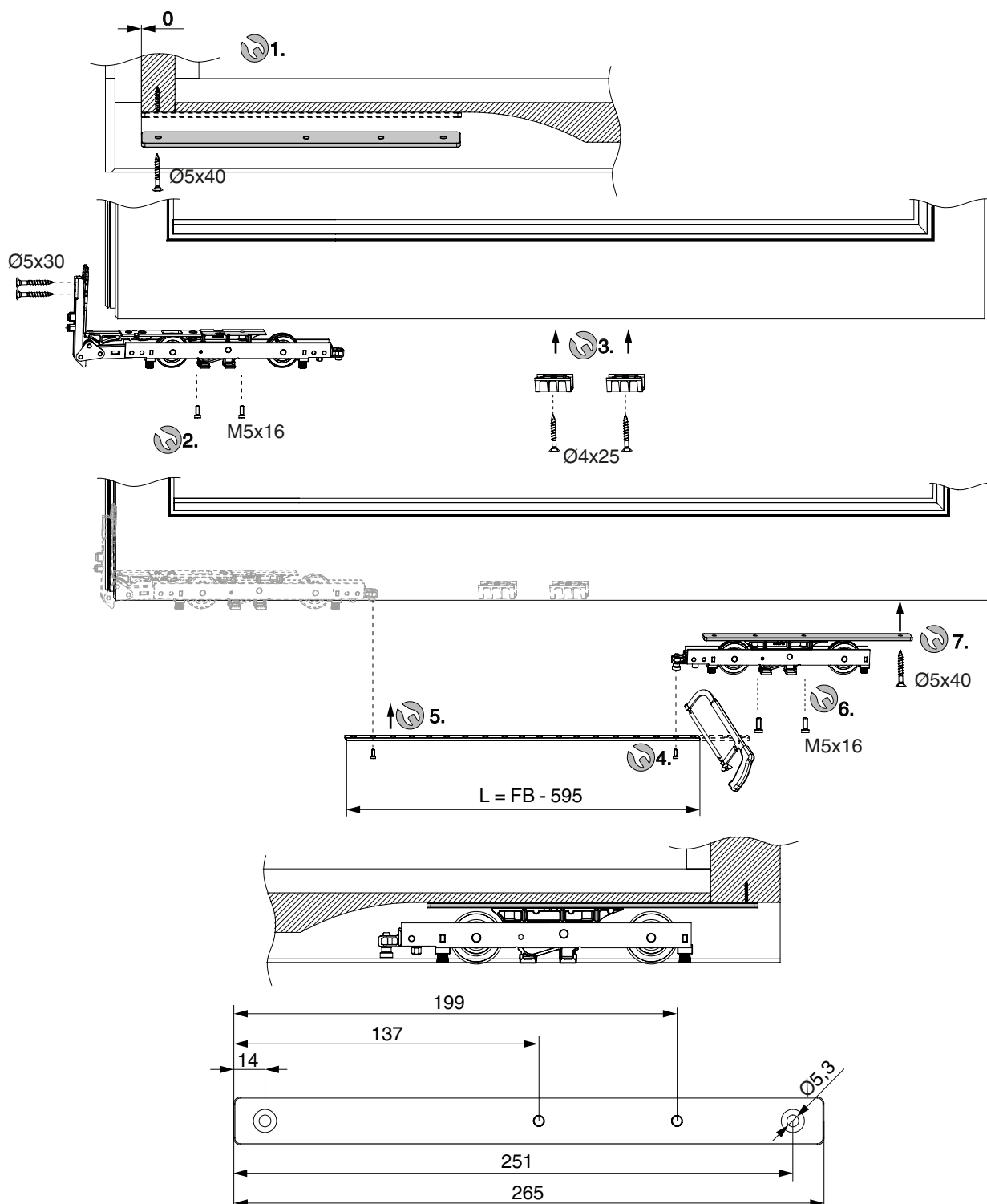

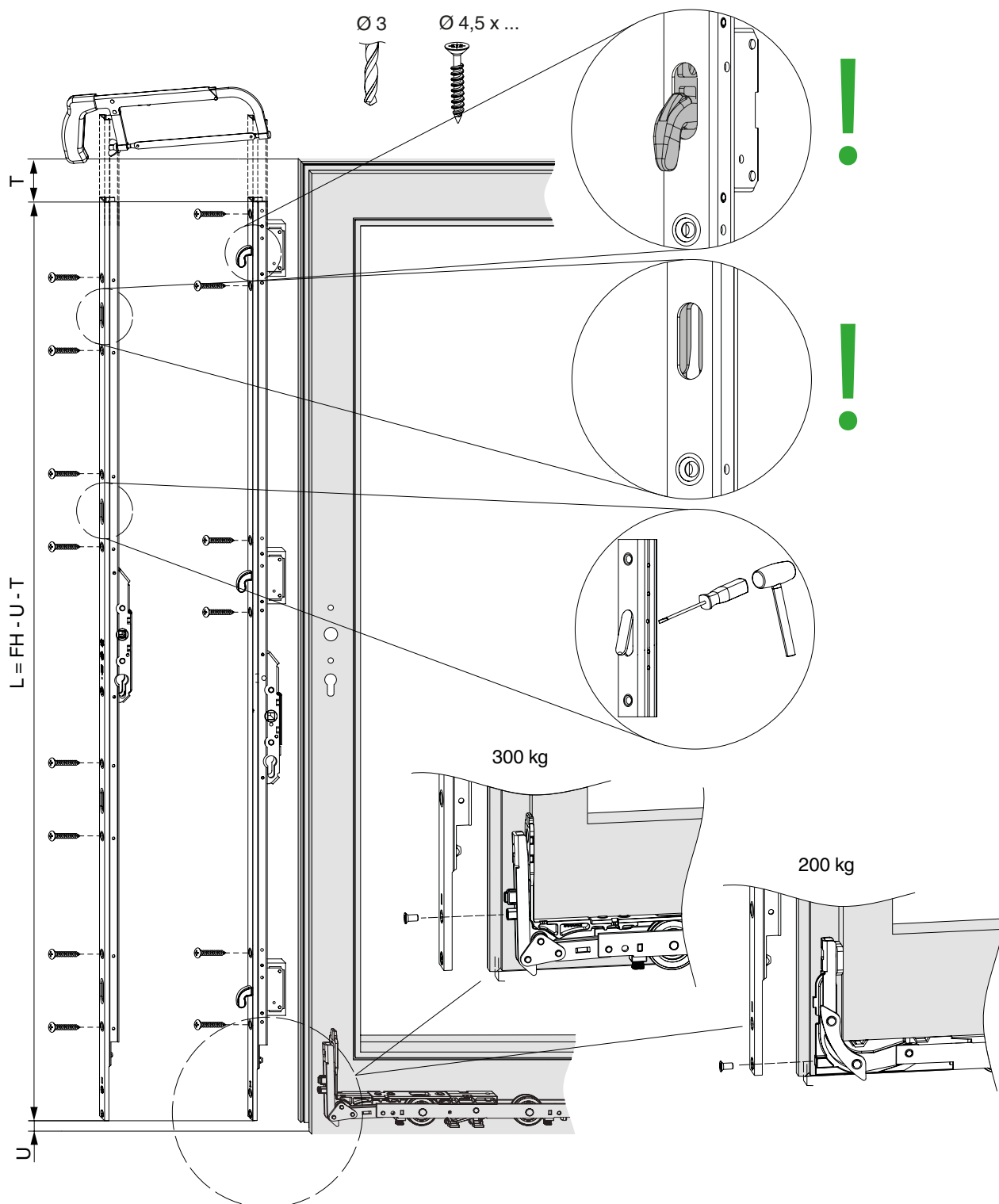

Sash installation

Drive gear assembly

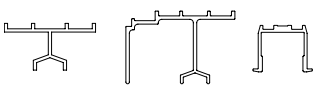

Sash installation

Drive gear assembly

	T = 50	T = 60
		
U = 10	60	70
	70	80

Handle fastening on drive gear with counter nut

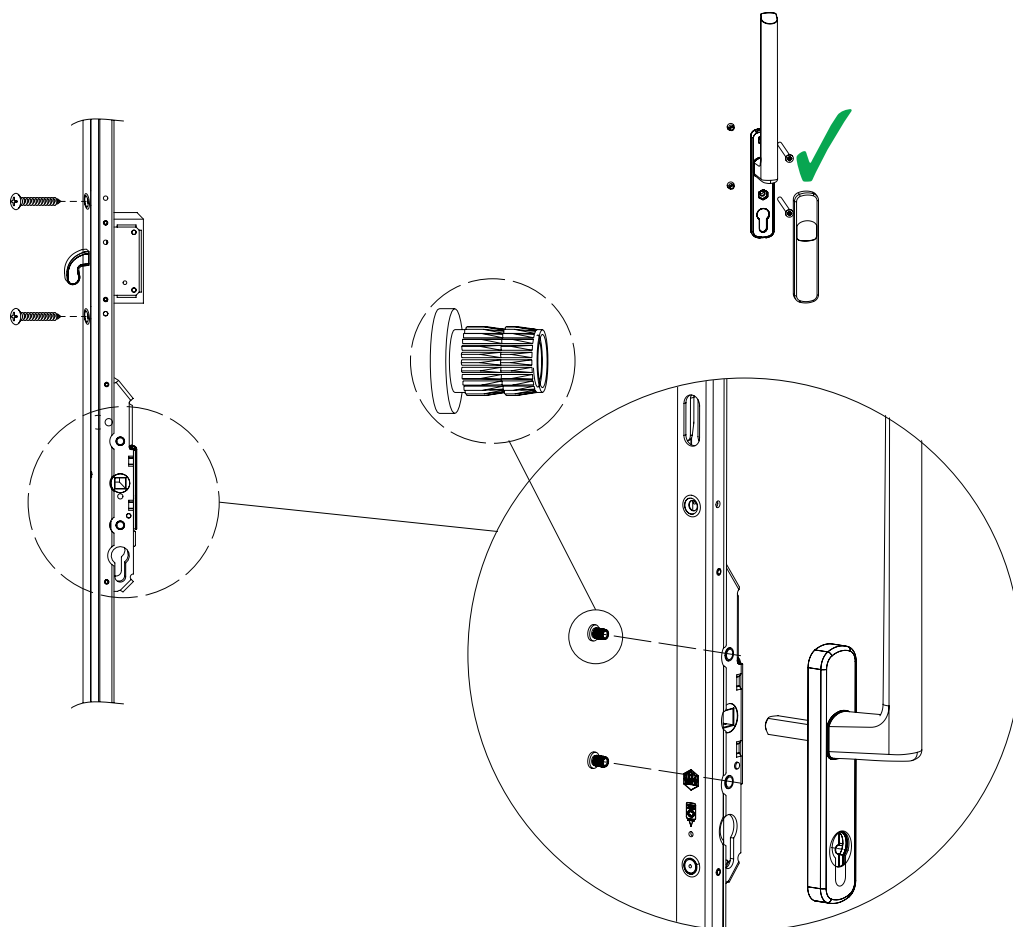

Sash installation

Drive gear damper

Warning!

If a damper is used, the application range is reduced by around 145 mm!
This item is recommended with sash weights over 200 kg.



Warning!

Distance piece provided by customer.

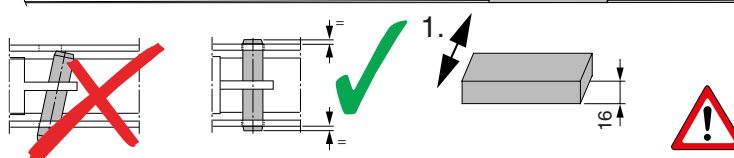
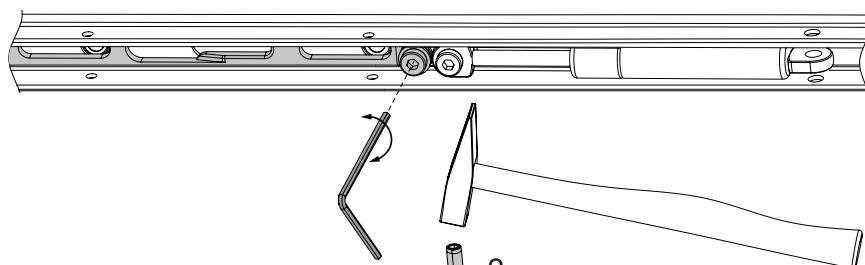
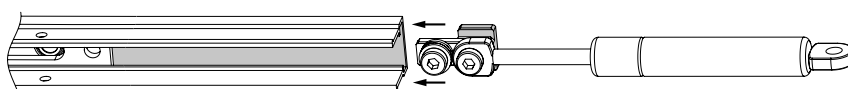
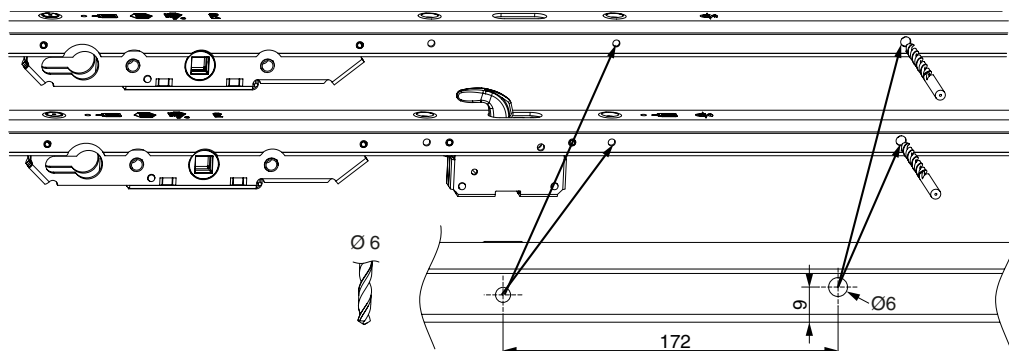

Sash installation

Drive gear damper

Warning!

A If locking monitoring is used, the application range is reduced by around 60 mm!

B If locking monitoring and a damper is used, the application range is reduced by around 190 mm!



Warning!

Distance piece provided by customer.

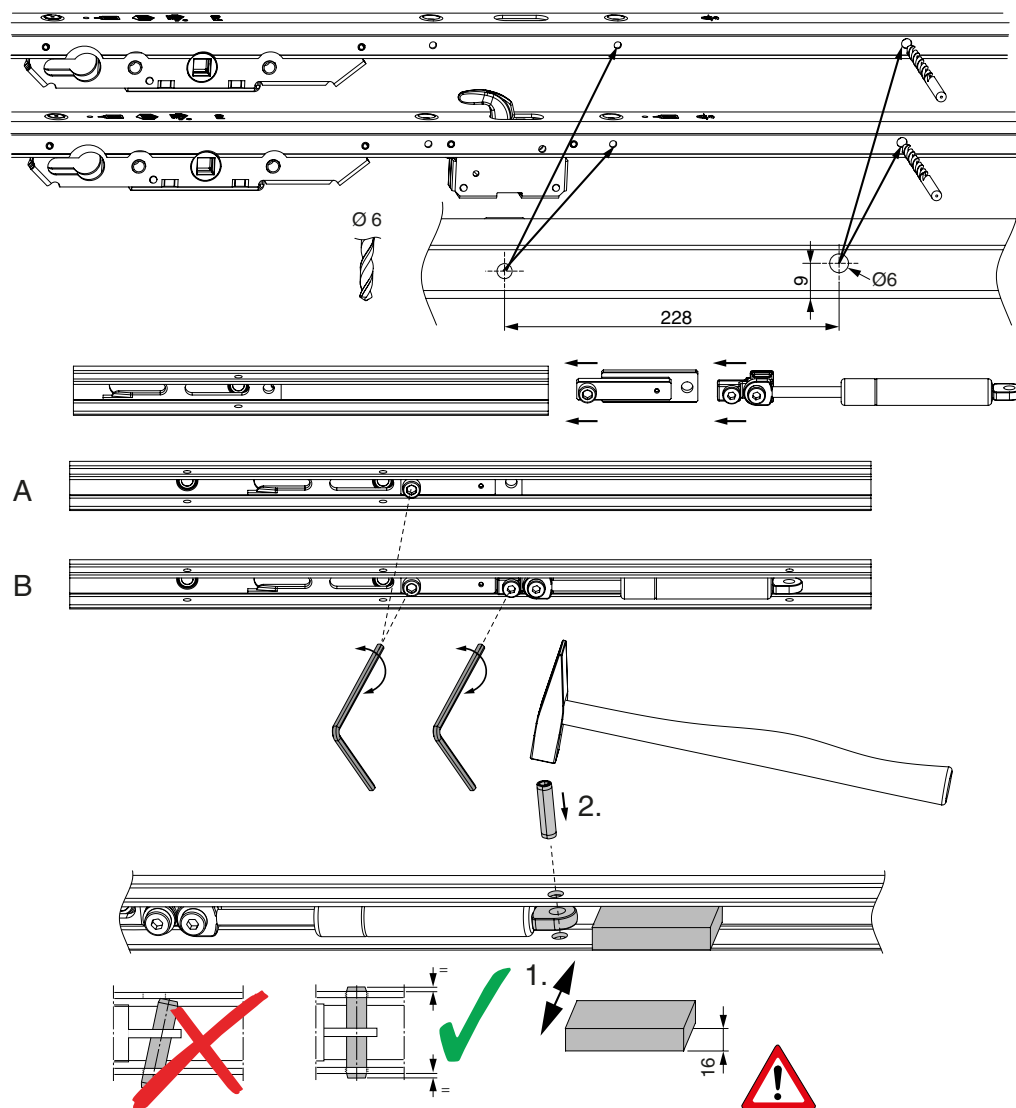

Sash installation

Handle fitting

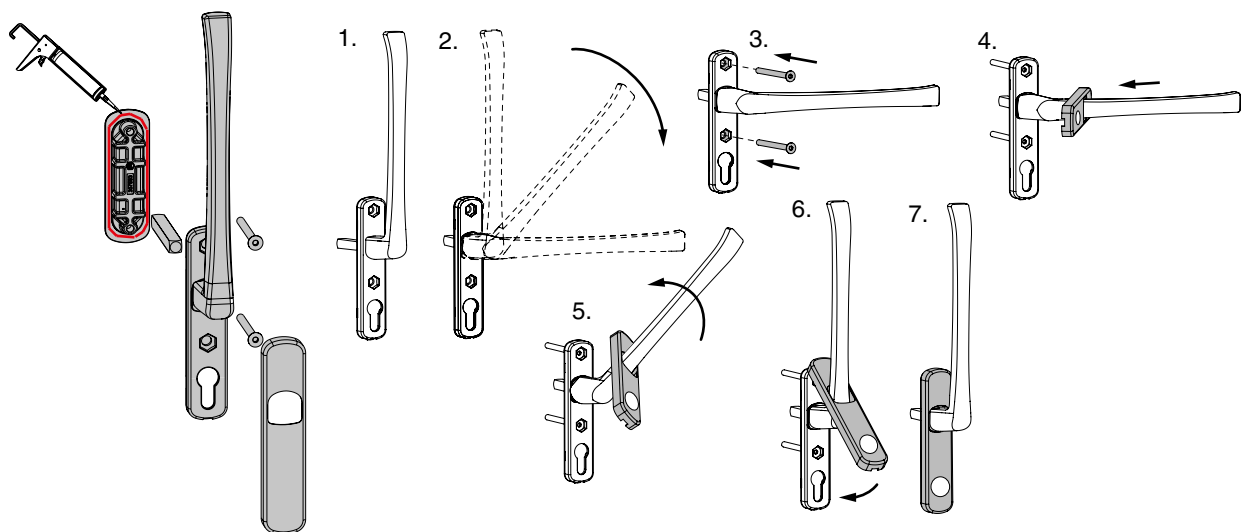
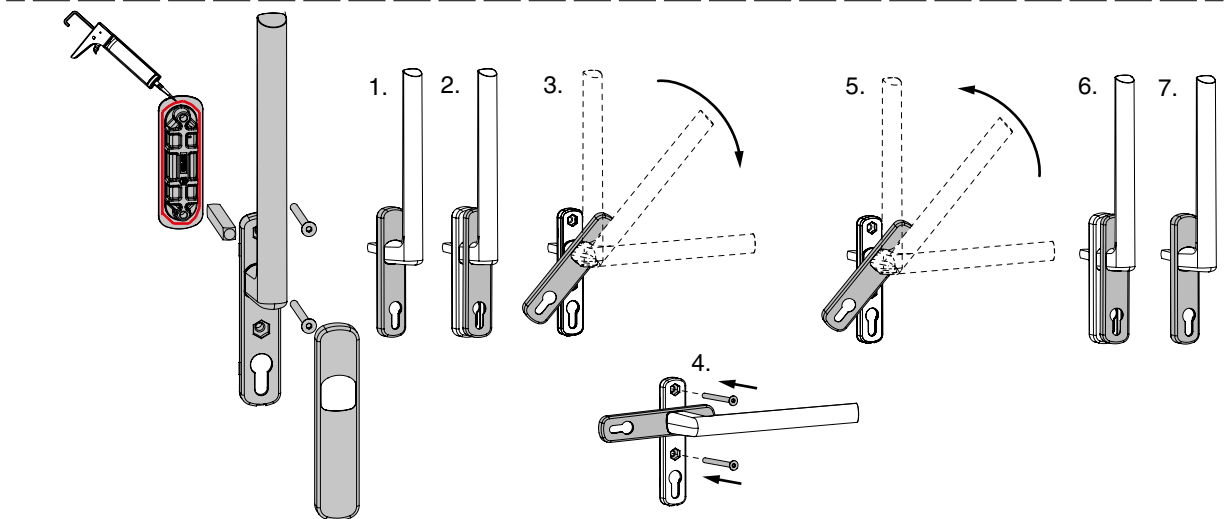
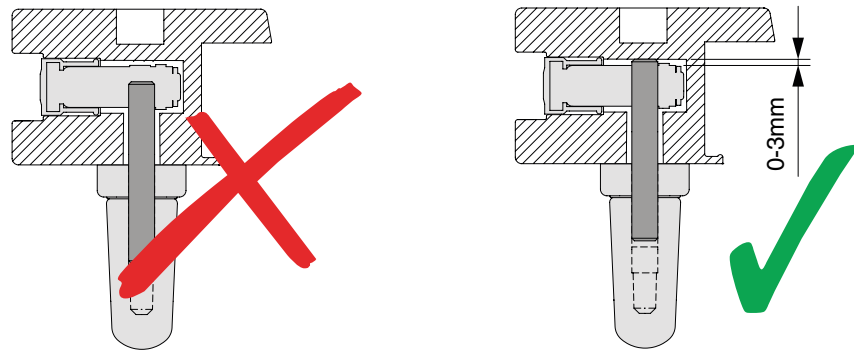

Sash installation

Sash gasket

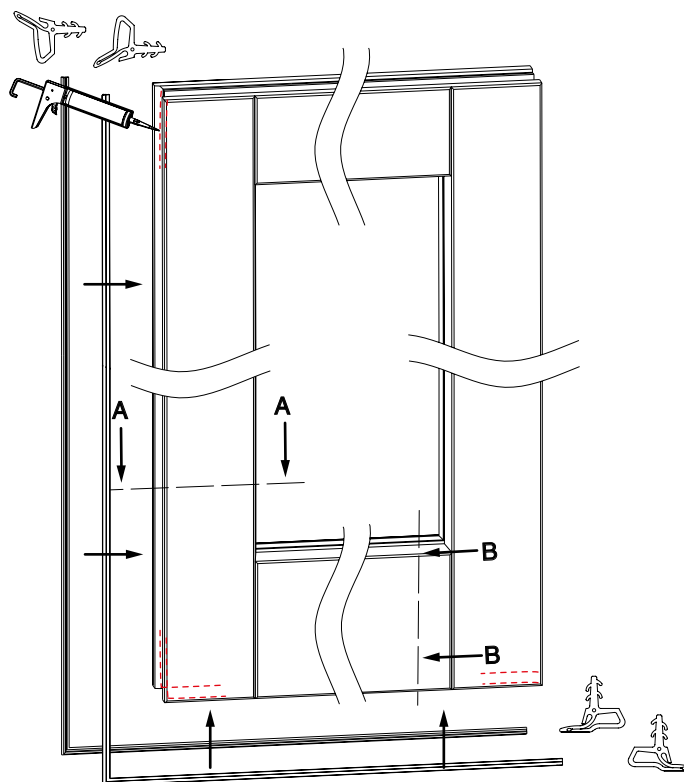

A-A

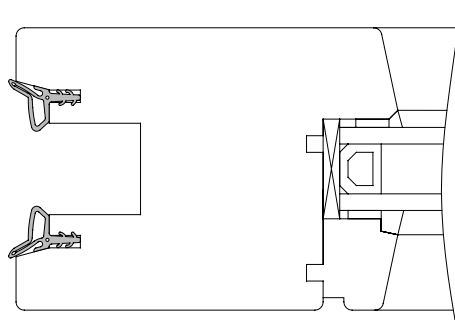

B-B

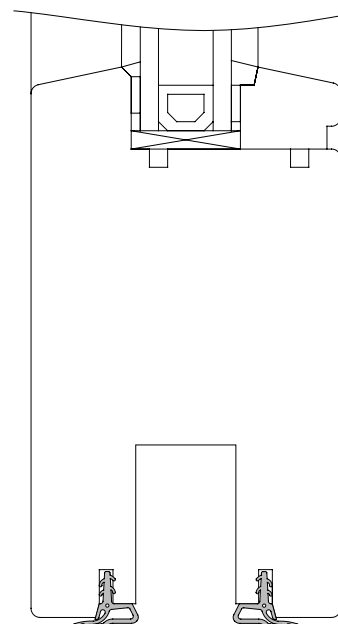

Sash installation

Gasket tracks

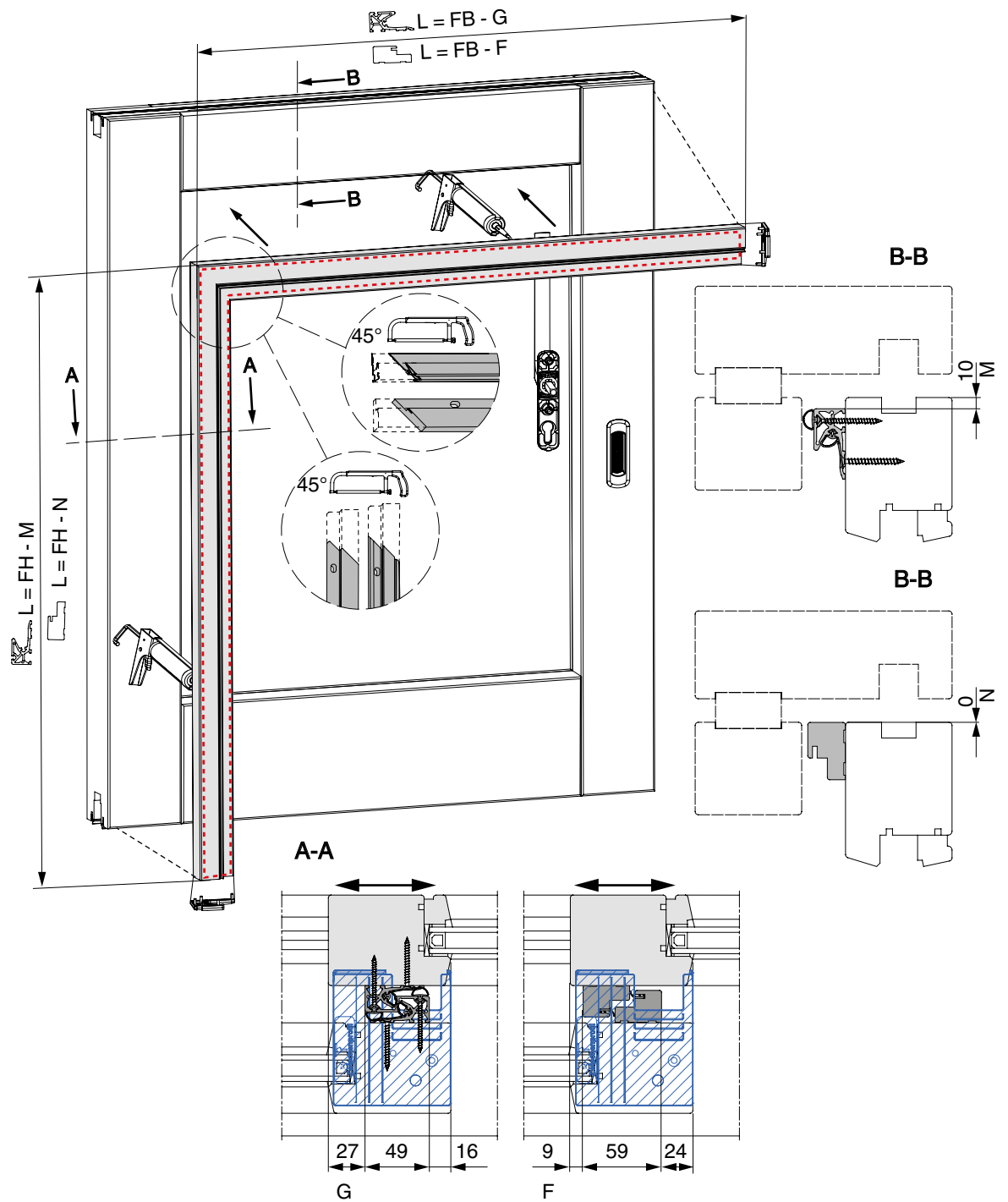

Sash installation

Gasket tracks

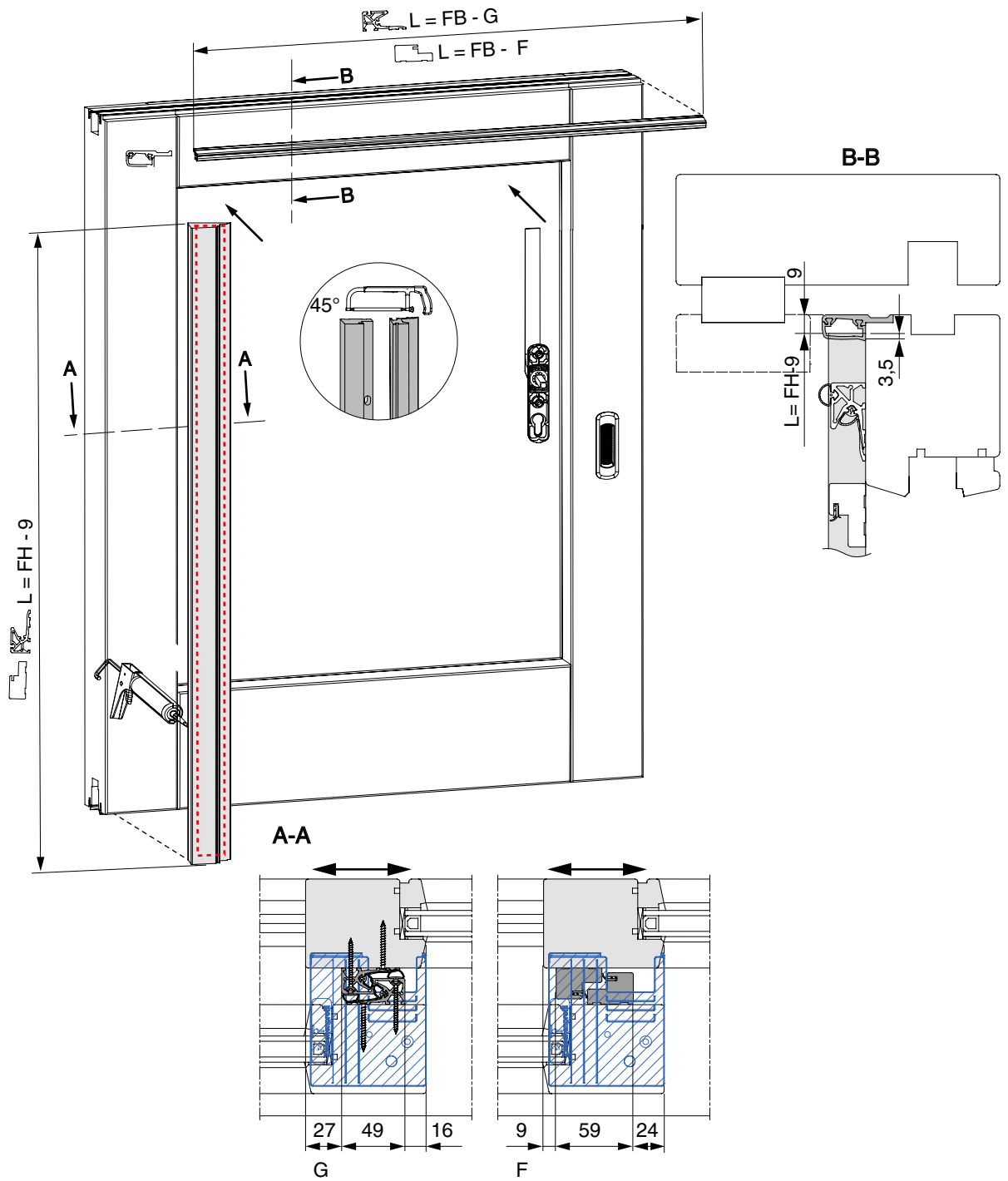

Sash installation

Gasket tracks

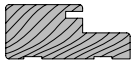

Timber

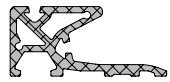
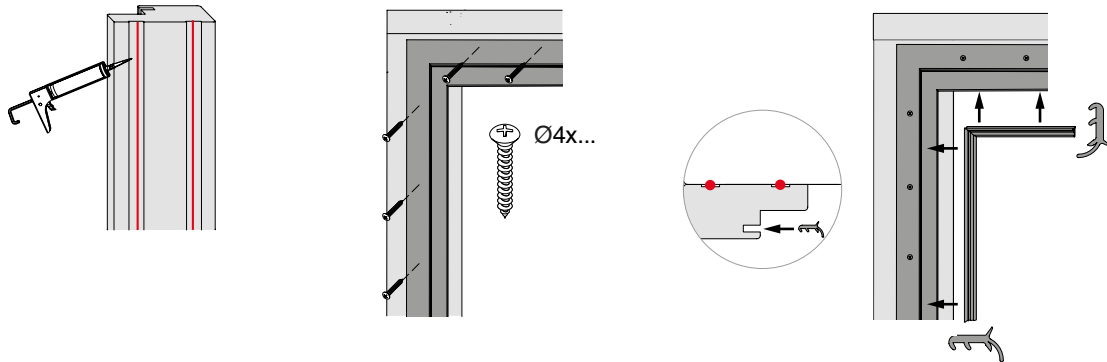

PVC

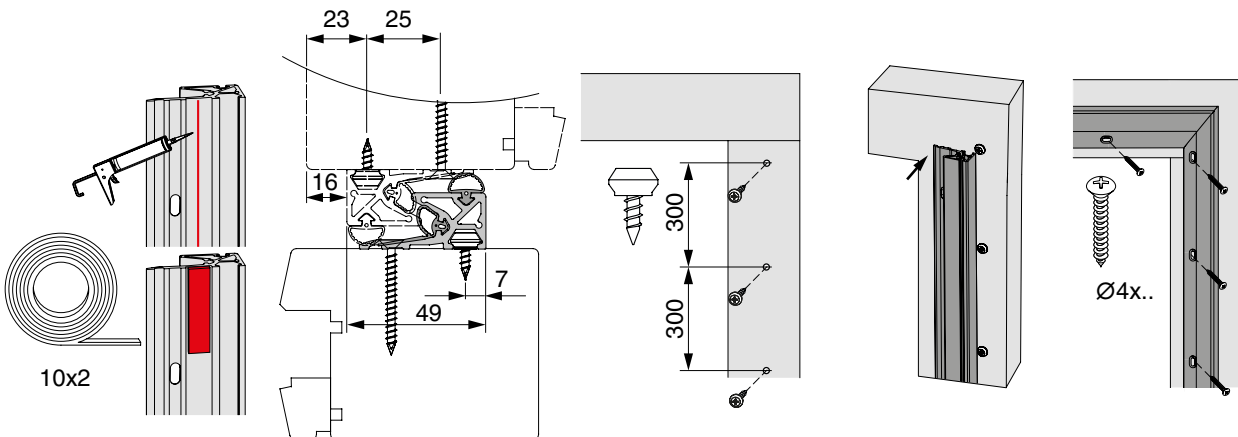
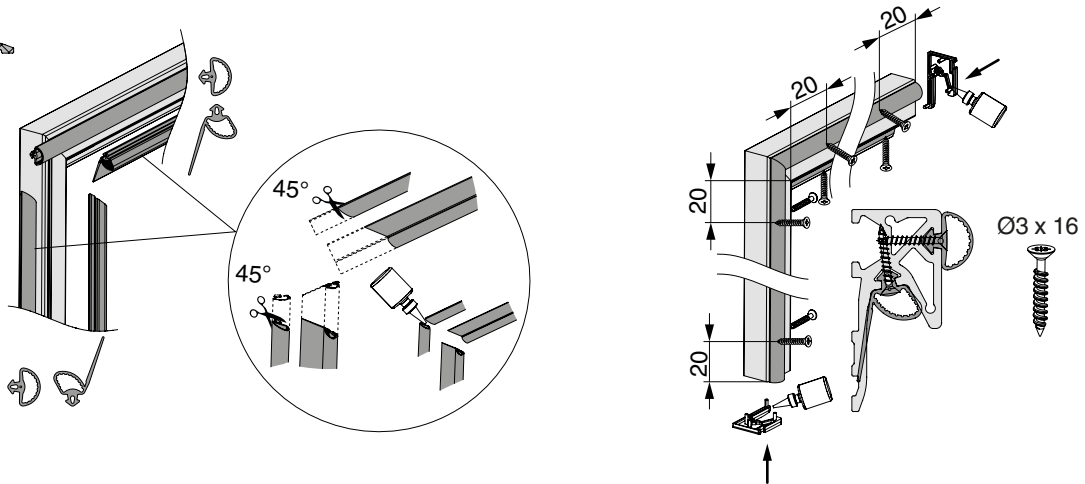

Sash installation

Gasket tracks

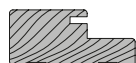

Timber

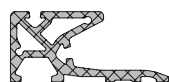

PVC

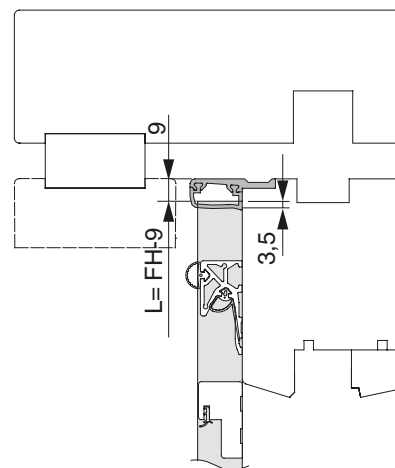
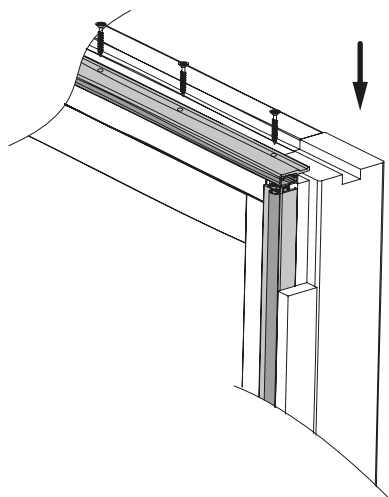
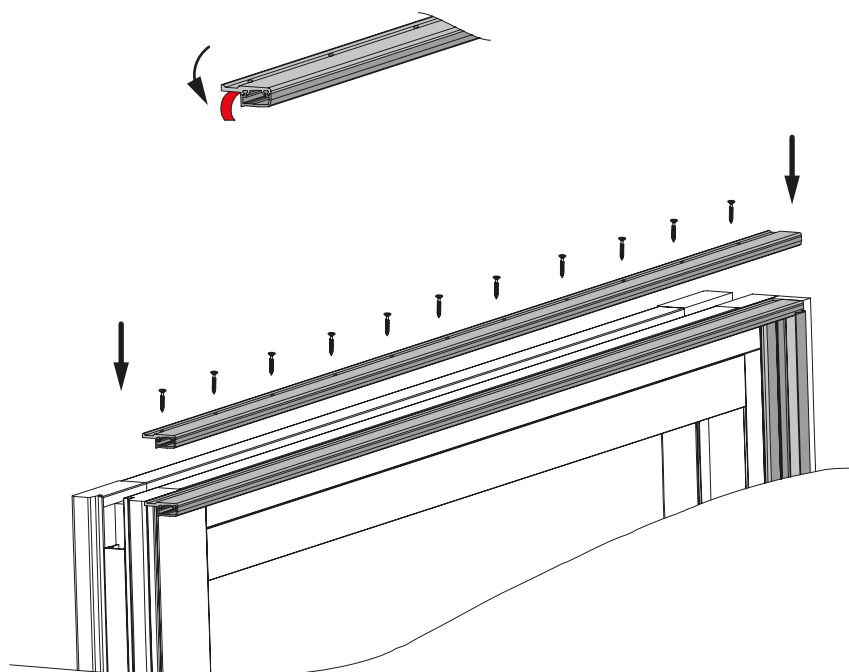

Sash installation

Foamed rubber and overlap gasket strip system C

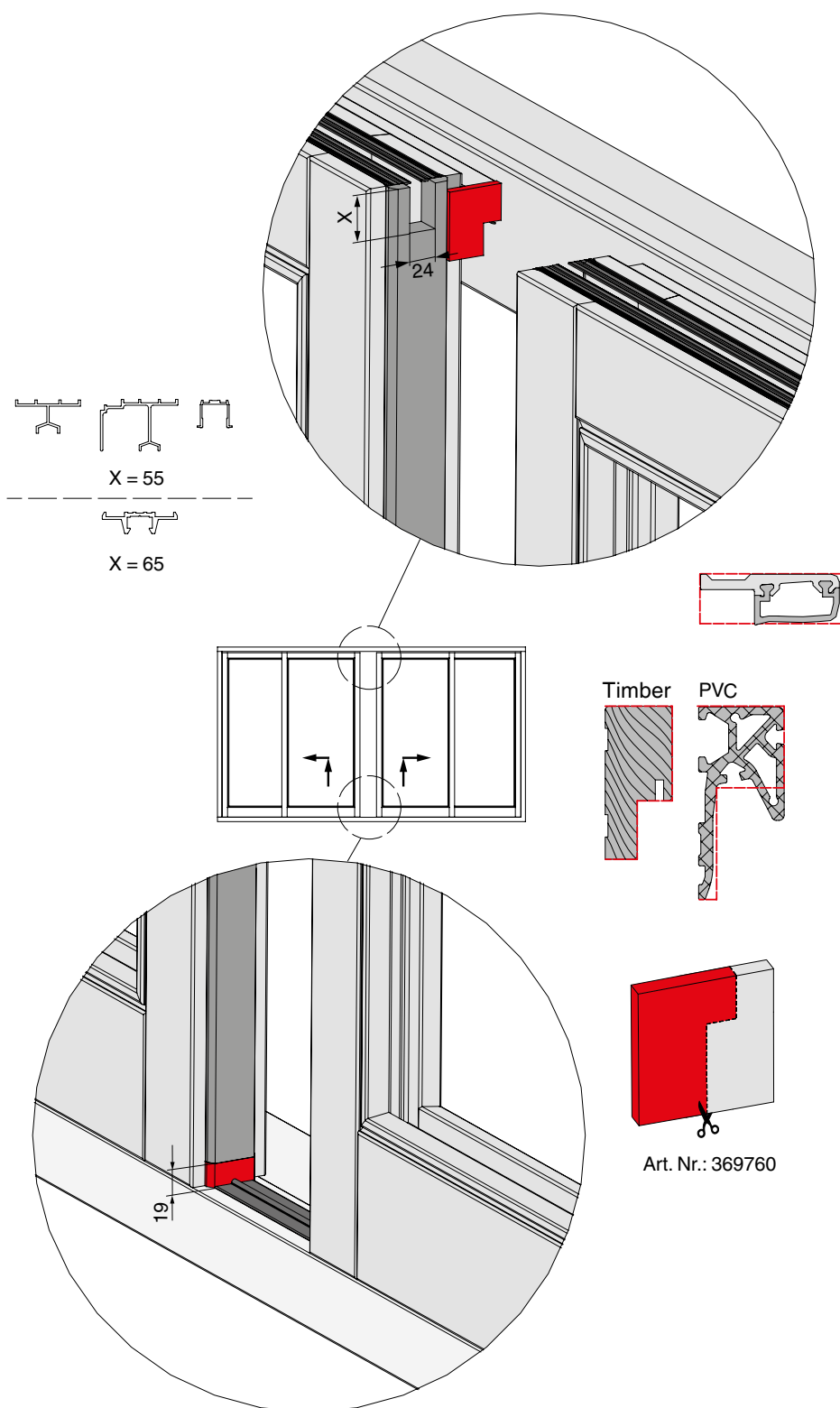

Sash and frame installation

Guide tracks and sash installation

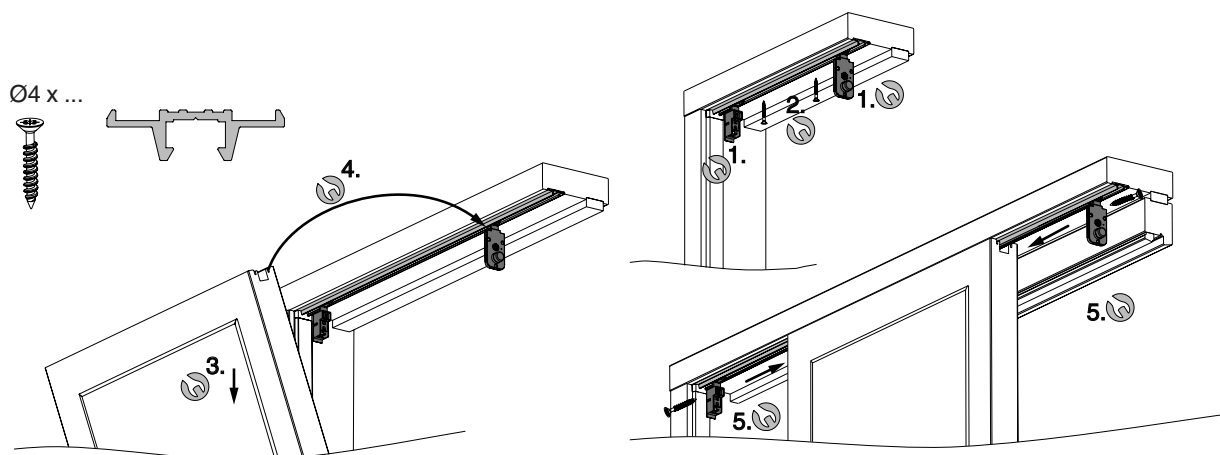
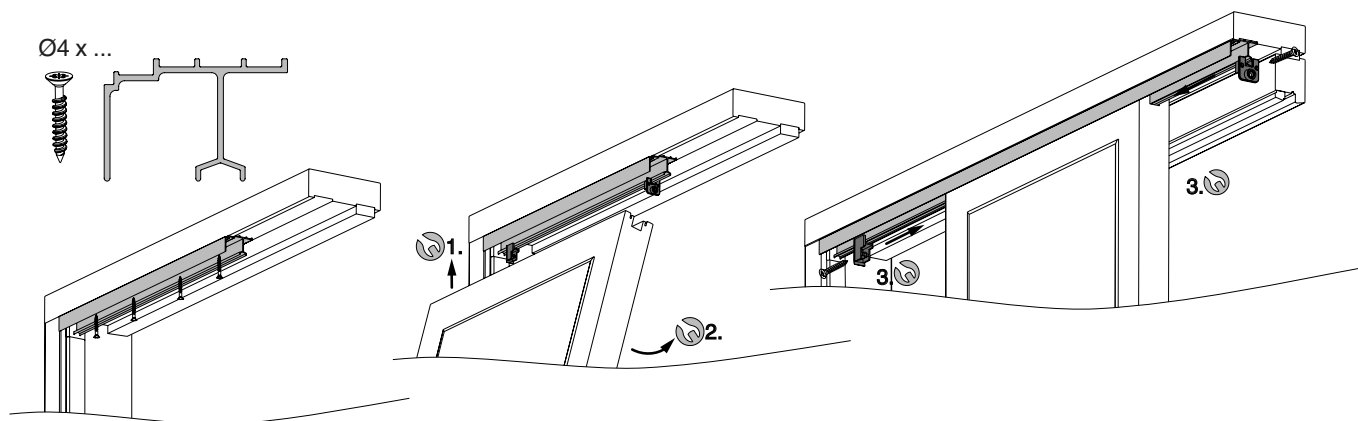
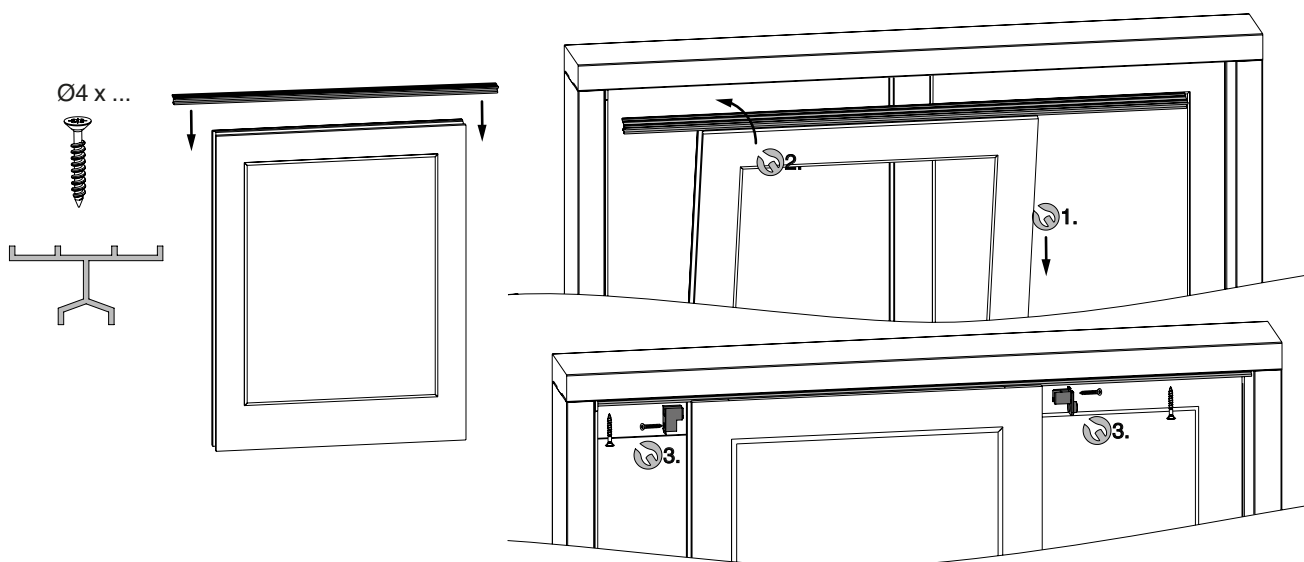

Sash and frame installation

Guide tracks and sash installation

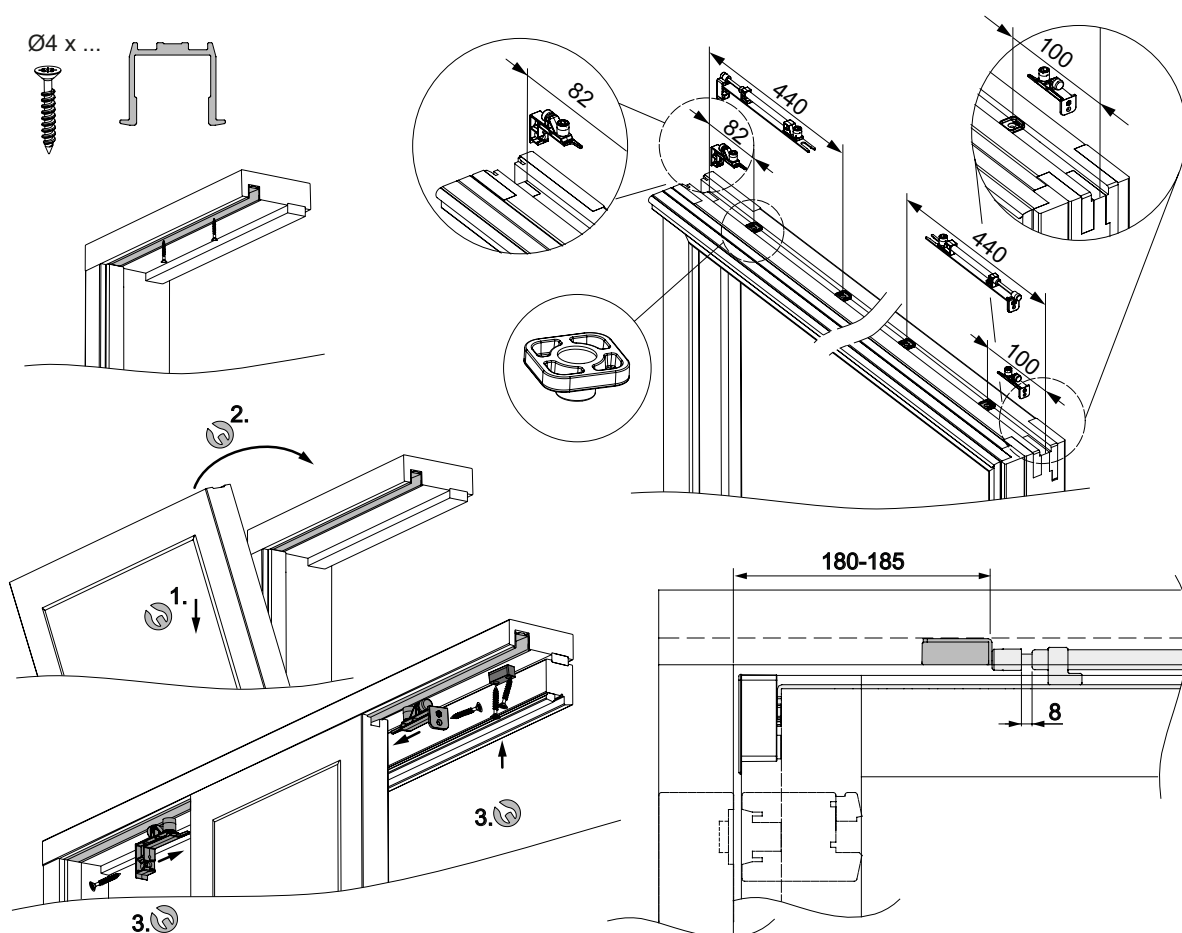
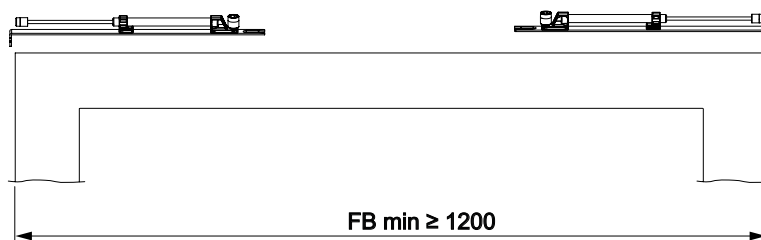
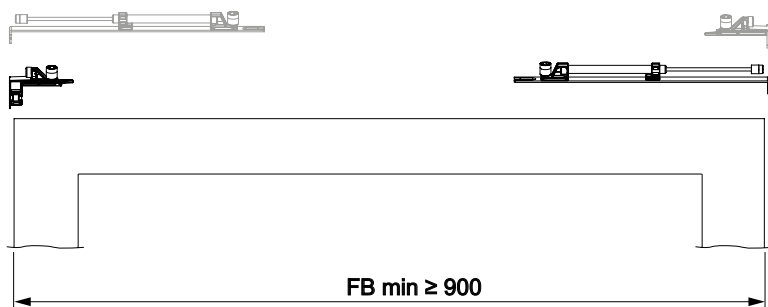

Sash and frame installation

Locking bolt

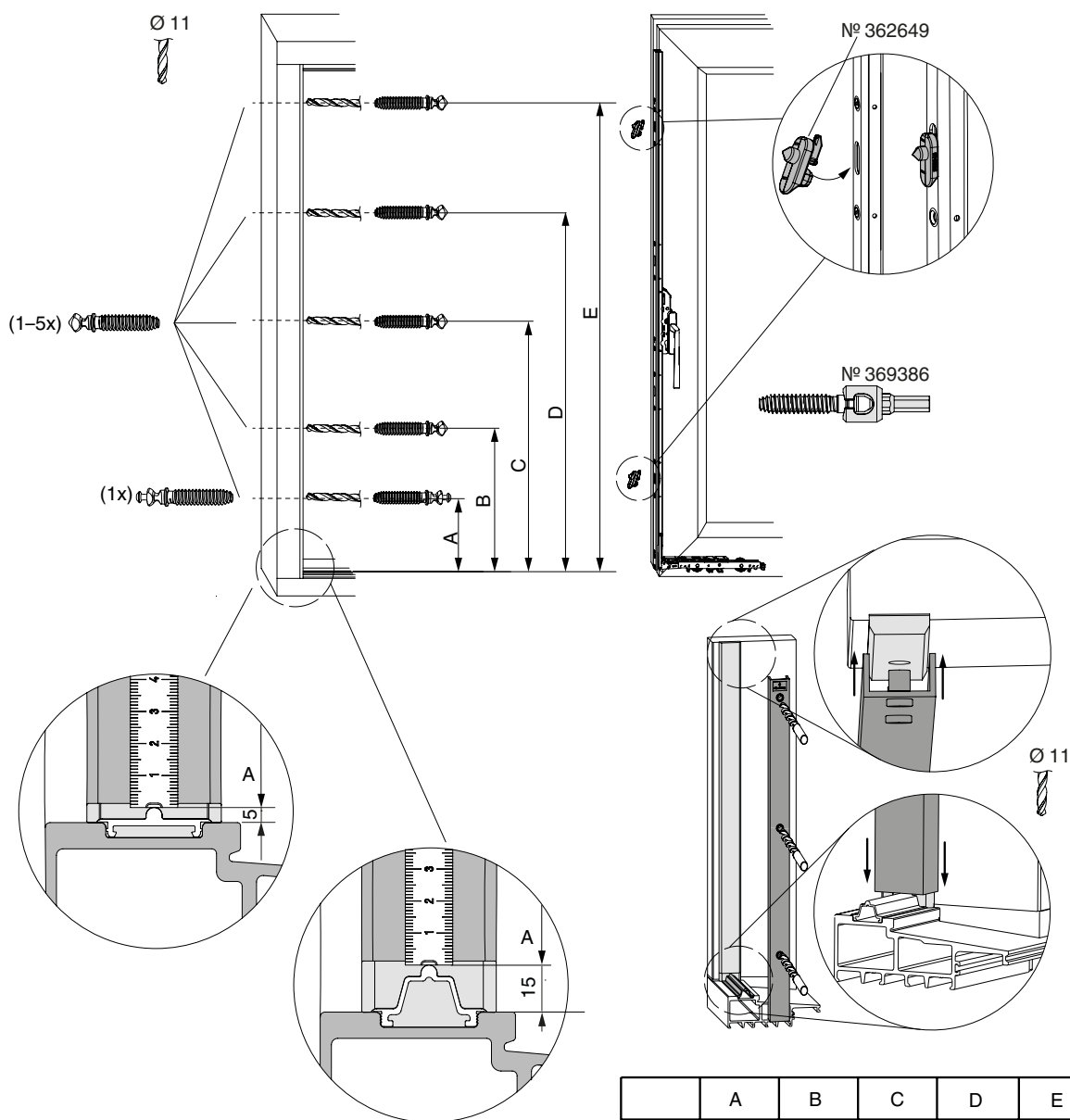

System C

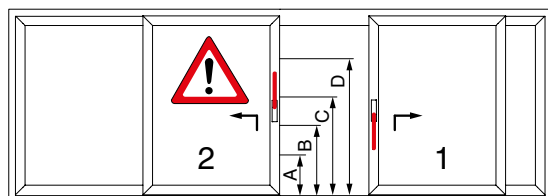

	A	B	C	D	E
Gr. 1	202	-	-	-	592
Gr. 2	202	-	-	592	1107
Gr. 3	202	-	702	1192	1507
Gr. 3,5	202	-	702	1192	1707
Gr. 4	202	-	702	1192	1907
Gr. 5	202	-	702	1192	2307
Gr. 6	202	702	1192	1907	2707
Gr. 7	202	702	1192	2307	3107

Sash and frame installation

Locking bolt system C

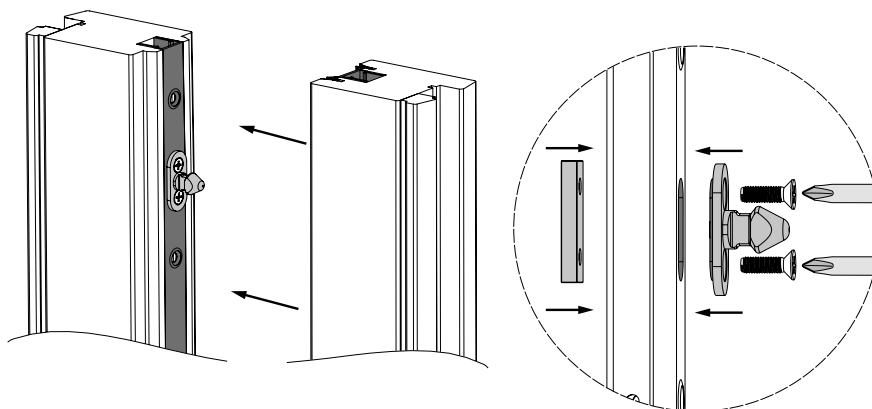
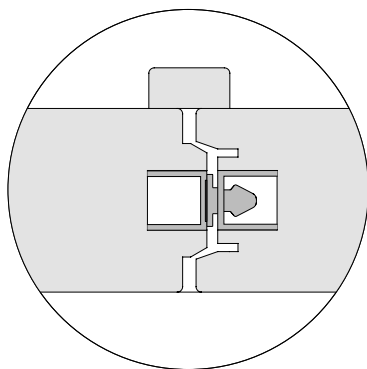
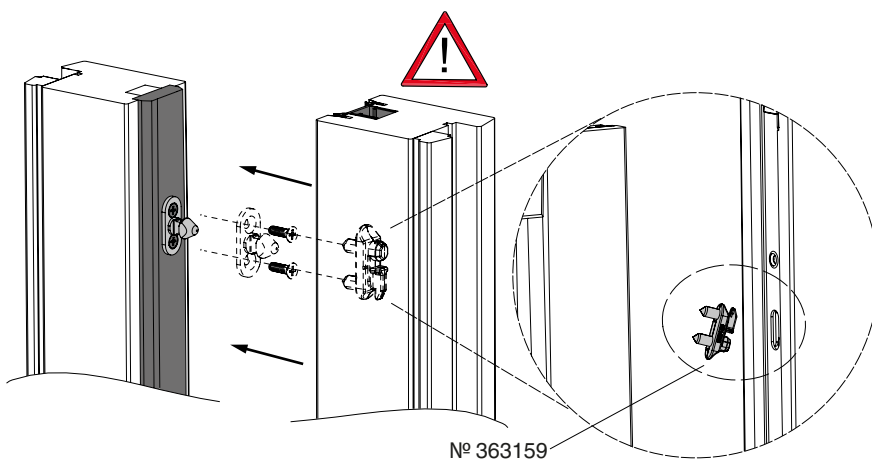
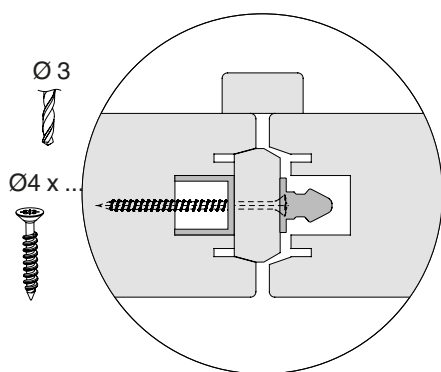
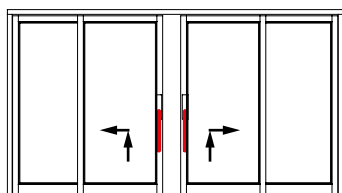

Sash and frame installation

Striker plate for hook gear system



Warning!

The installation length must always be selected so that the MACO logo is positioned at the top!



Warning!

Turn the striker plate by 180°!
If the striker plates are set too high, there is a risk that the handle will be tilted, the production tolerance can be compensated by turning the striker plate (dimension Z).

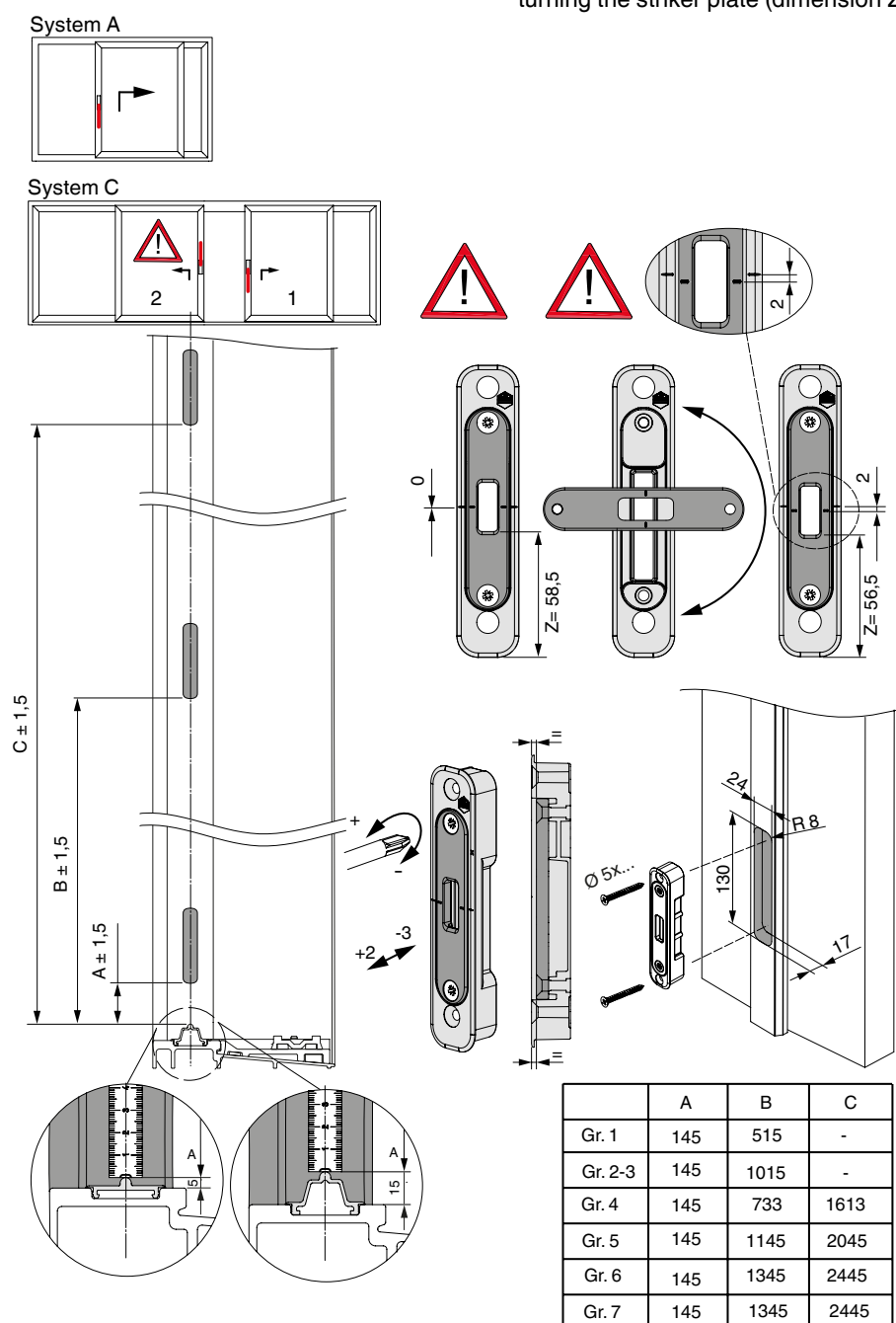

Sash and frame installation

Grease hook drive gear

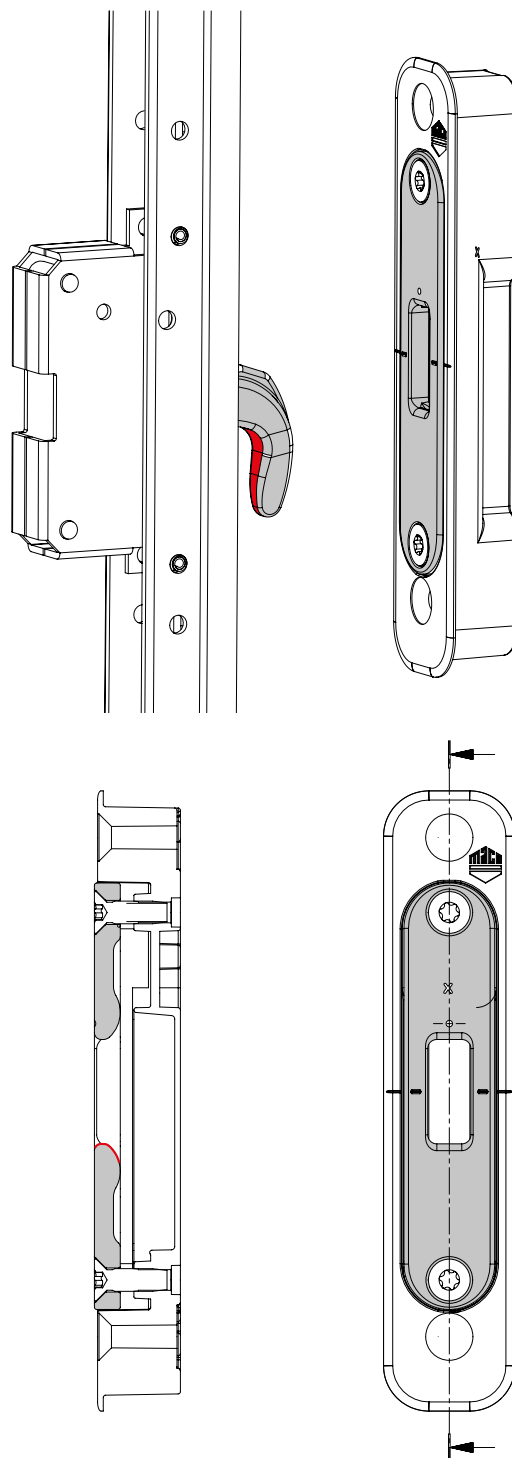

Grease for hardware:
Lubricant with PTFE in spray form, for example, OKS 3751 or equivalent

Sash and frame installation

Striker plate for hook gear system C

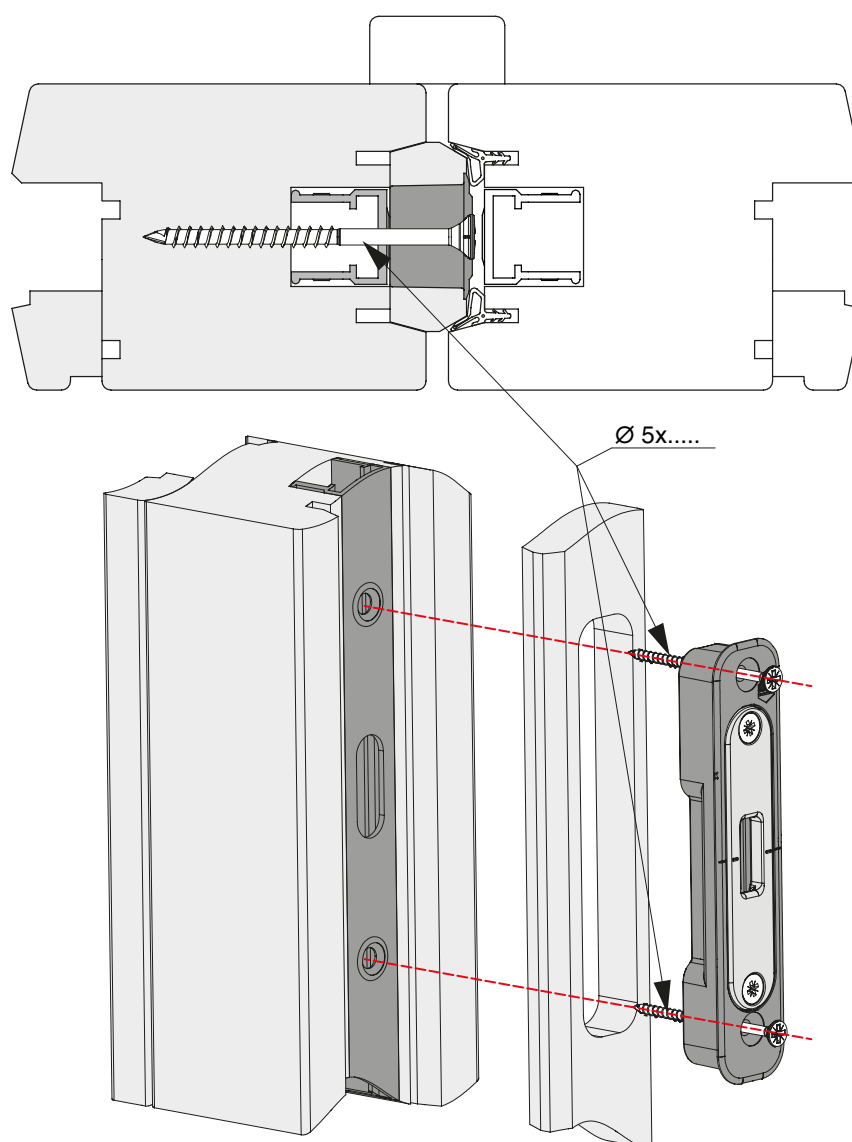

Installation of accessories

Standard buffer stop

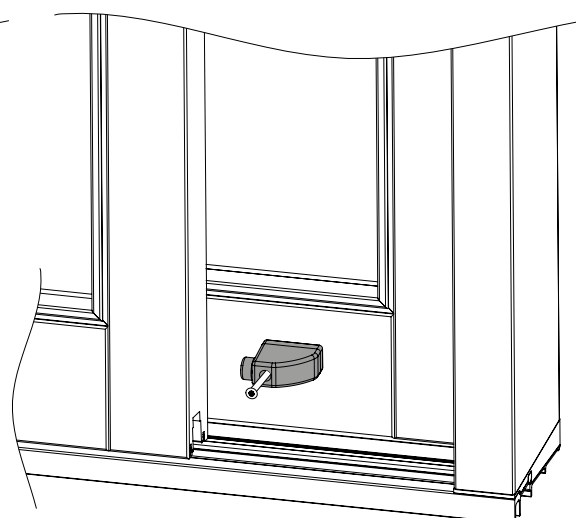
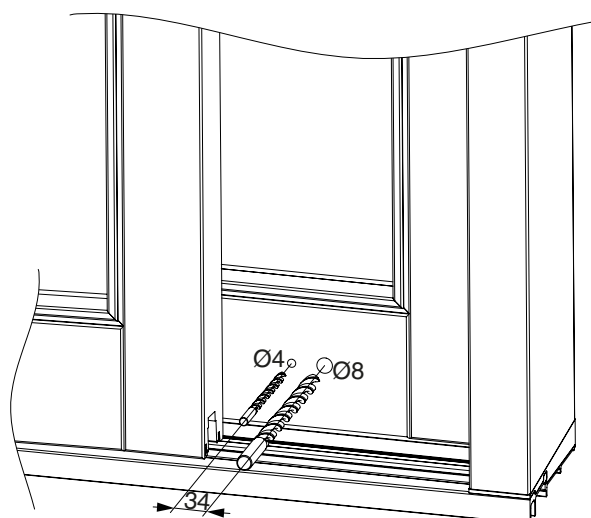
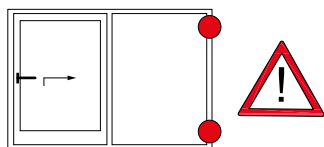
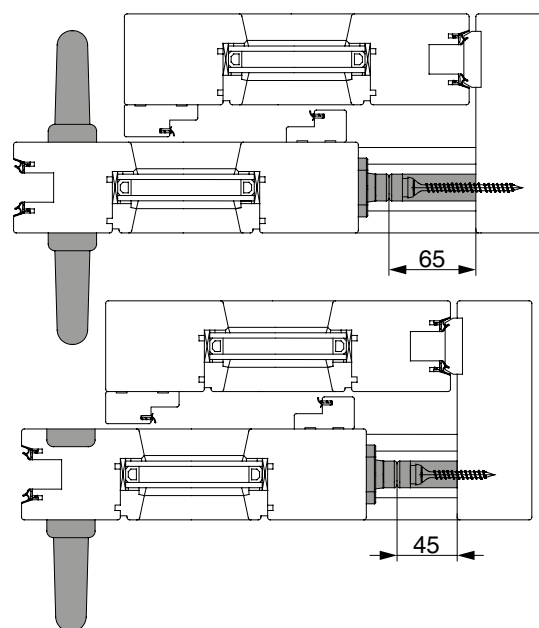
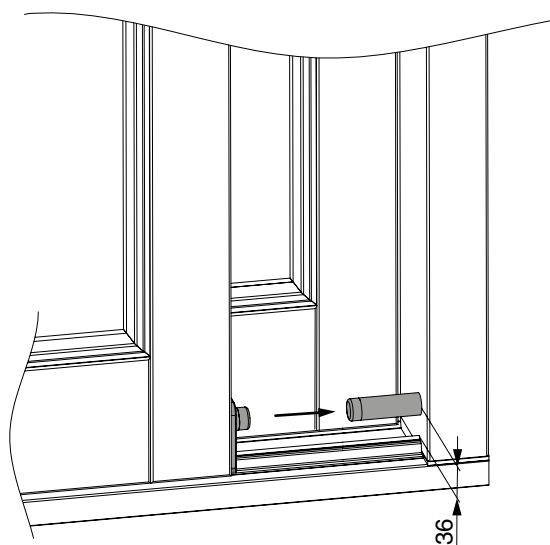

Installation of accessories

Guide and roller track buffer stop

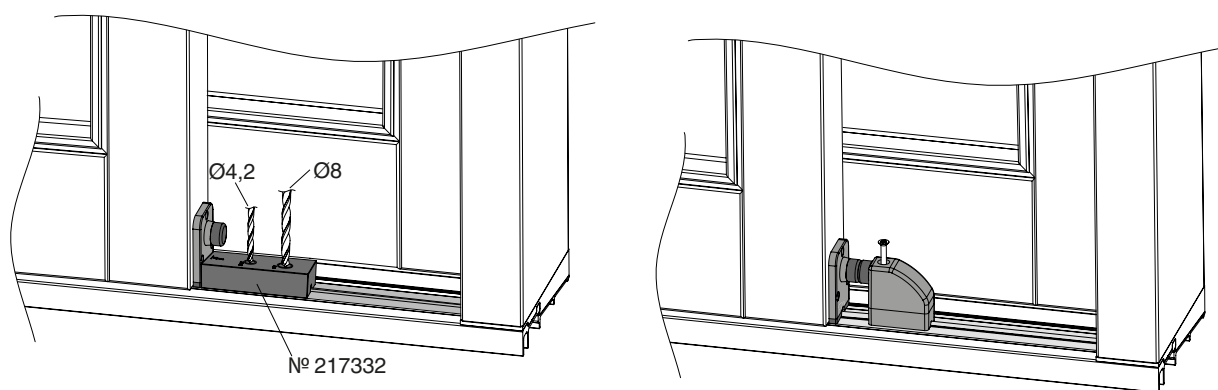
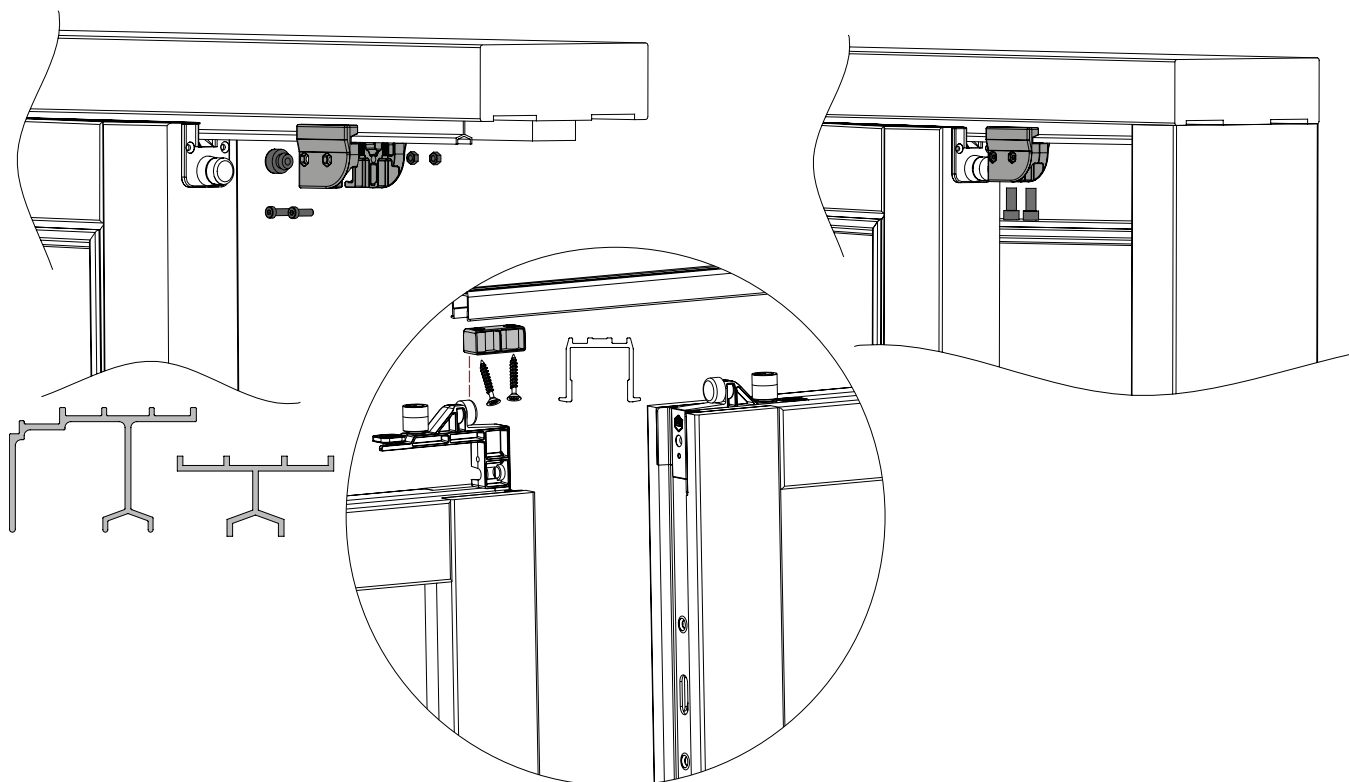

Installation of accessories

Locking block

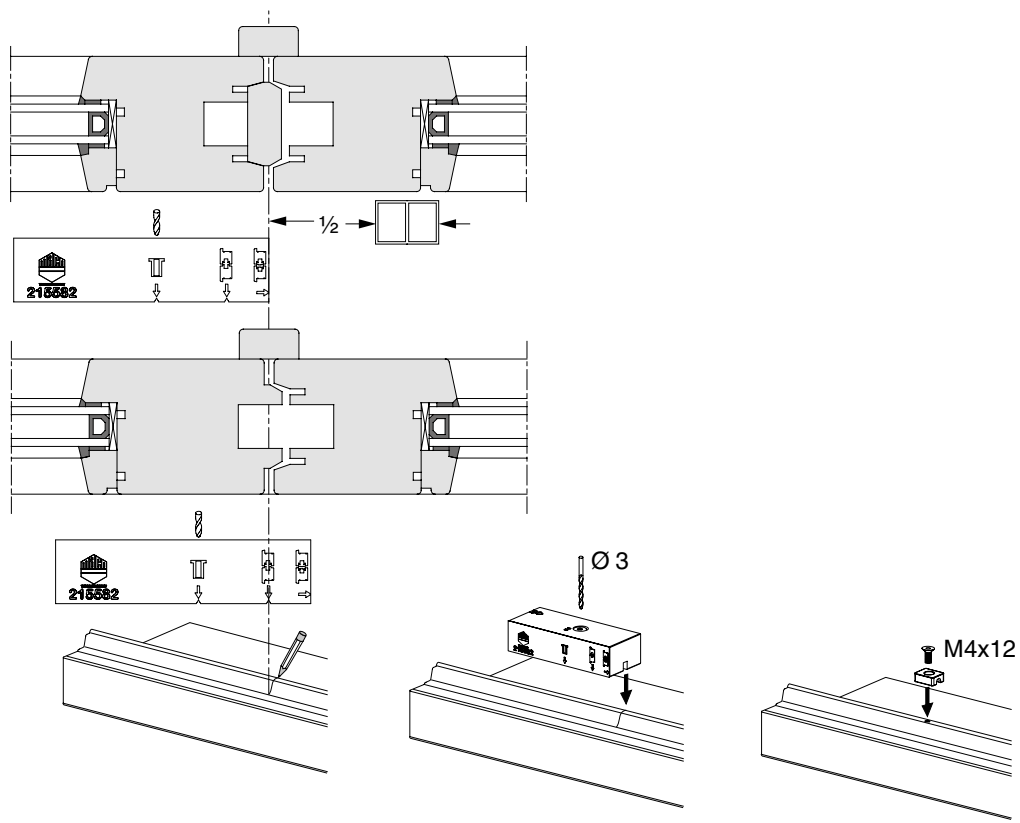

200 kg

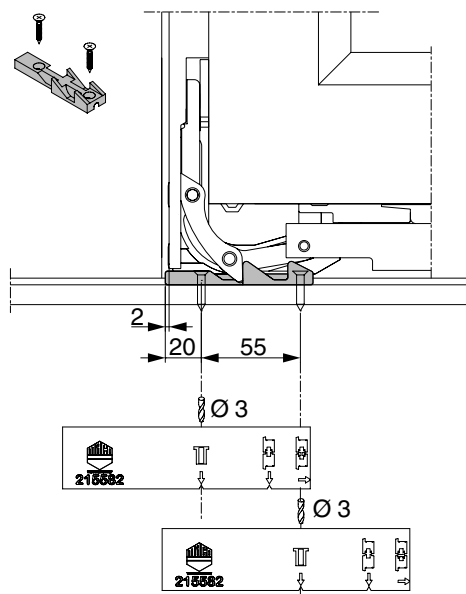

300/400 kg

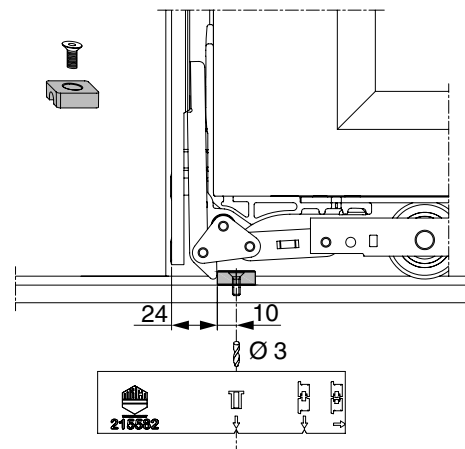

Installation of accessories

Low threshold tread board walkway area

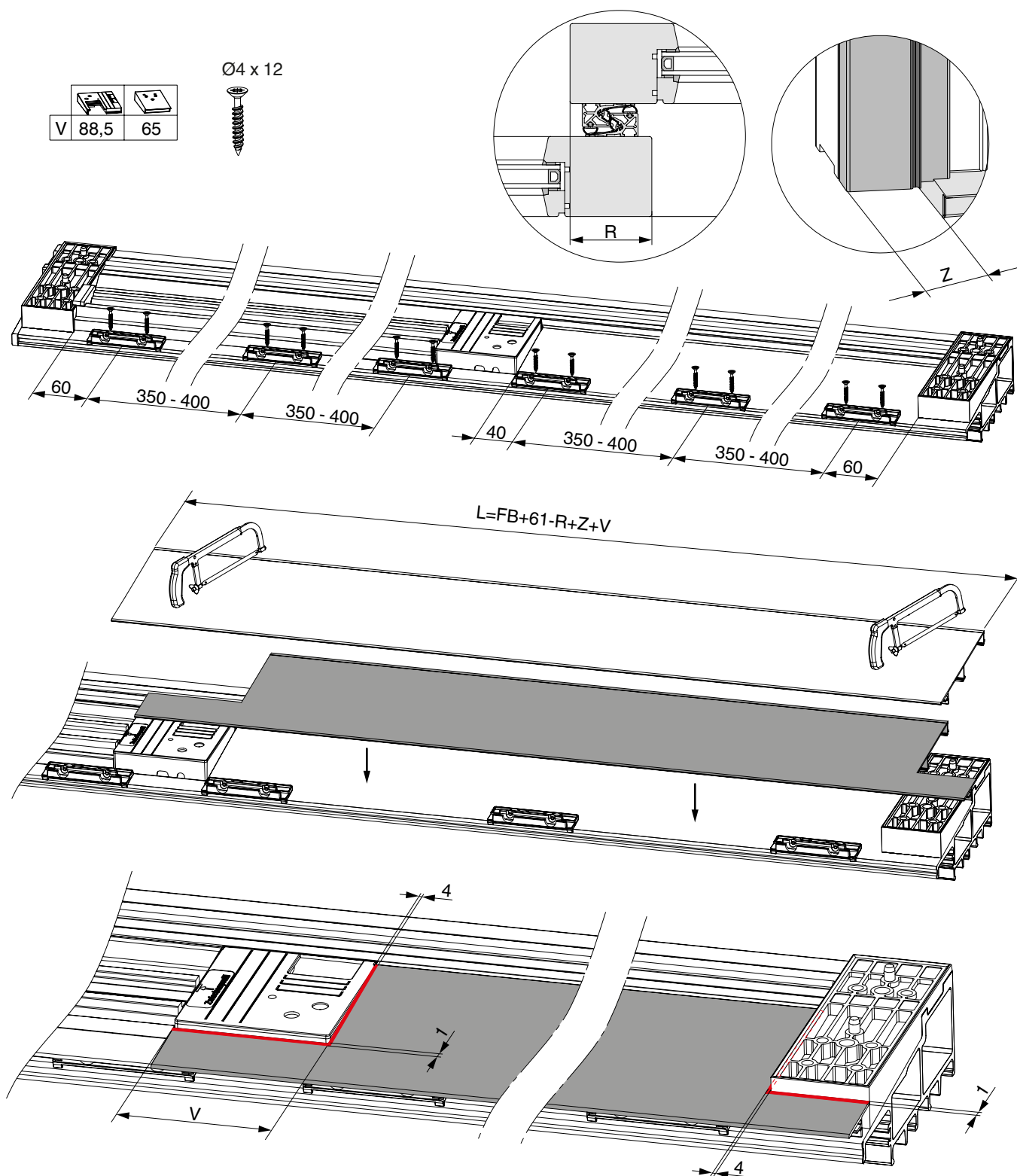

Installation of accessories

Fixed sash low threshold tread board

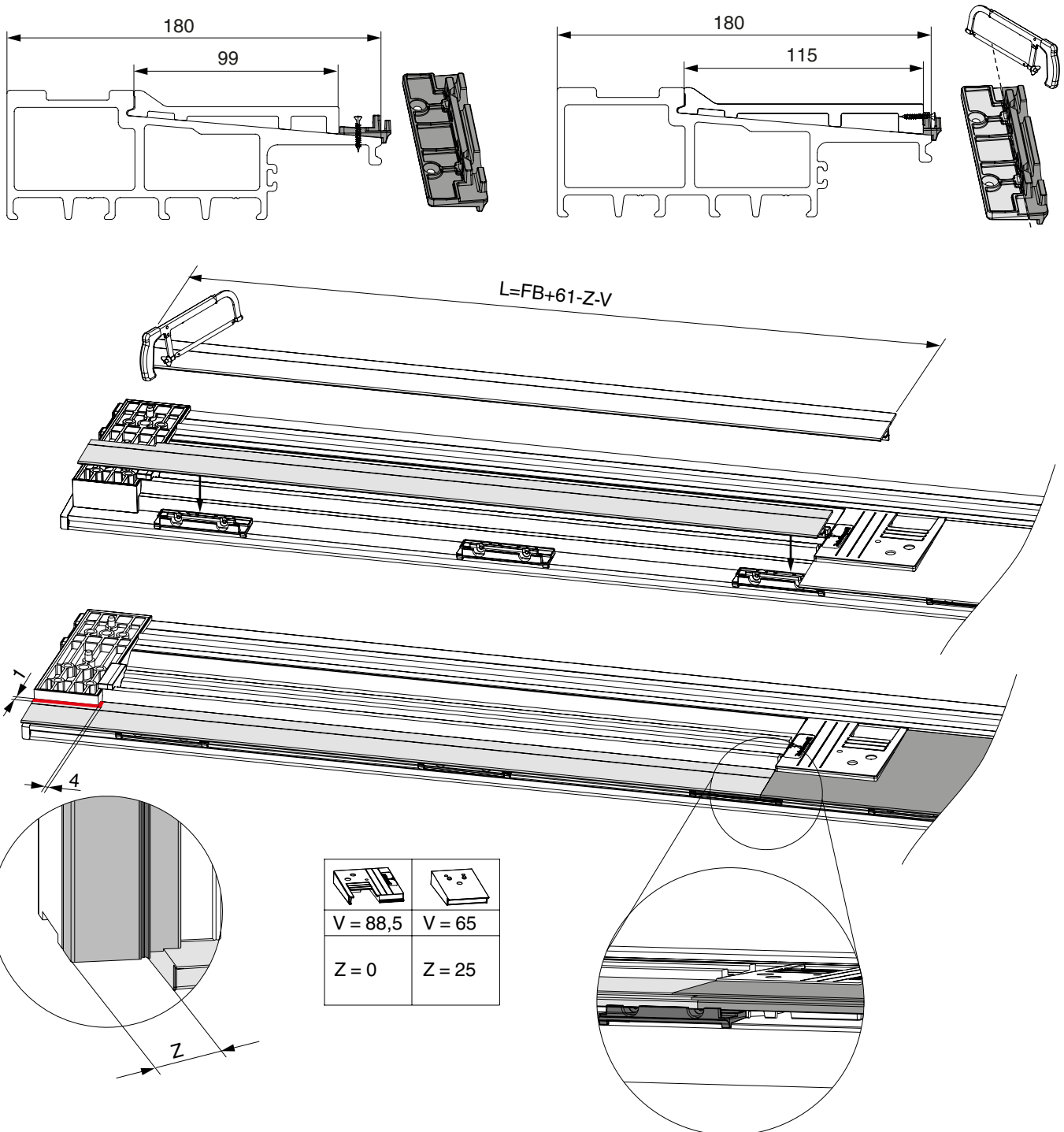



Lower sliding sash in opened position!

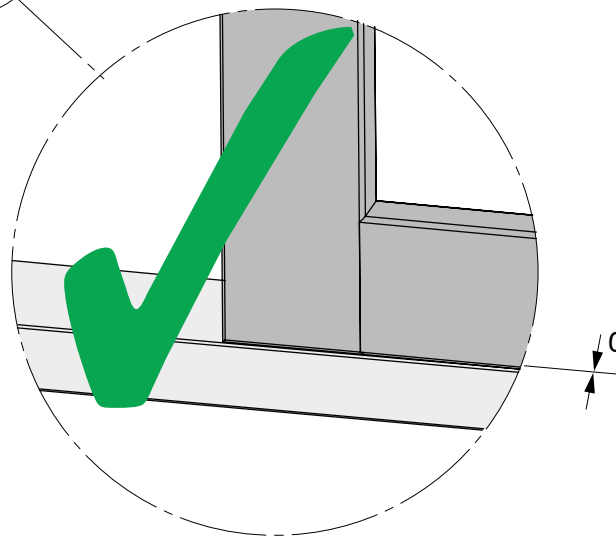
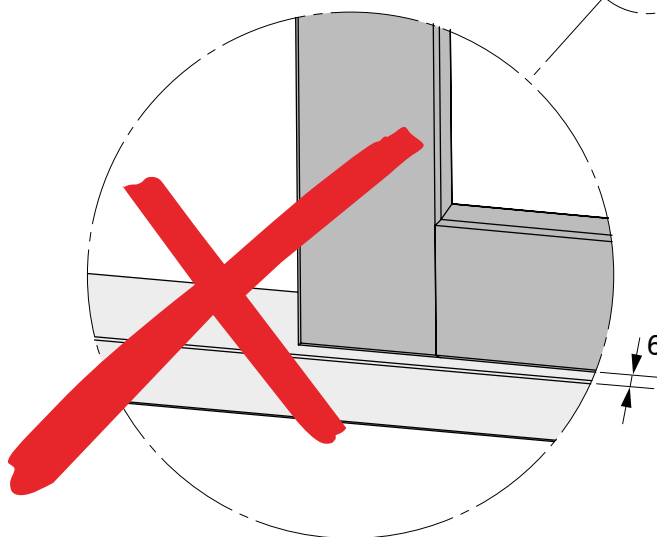
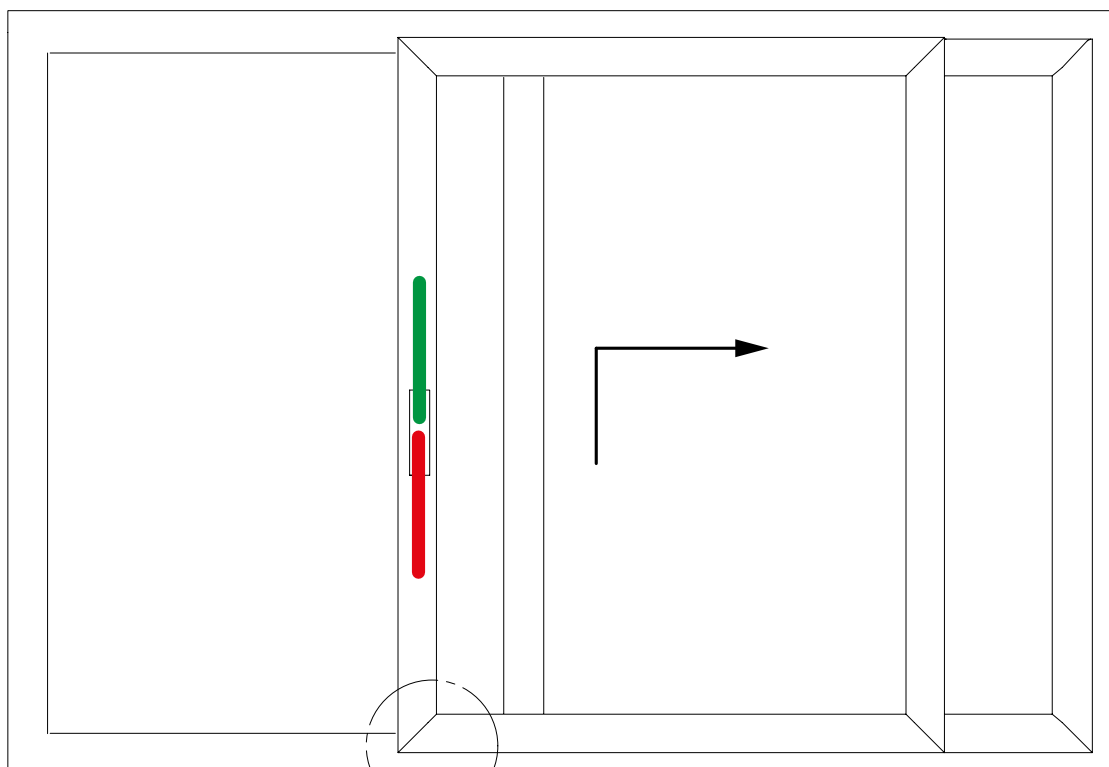

Notes

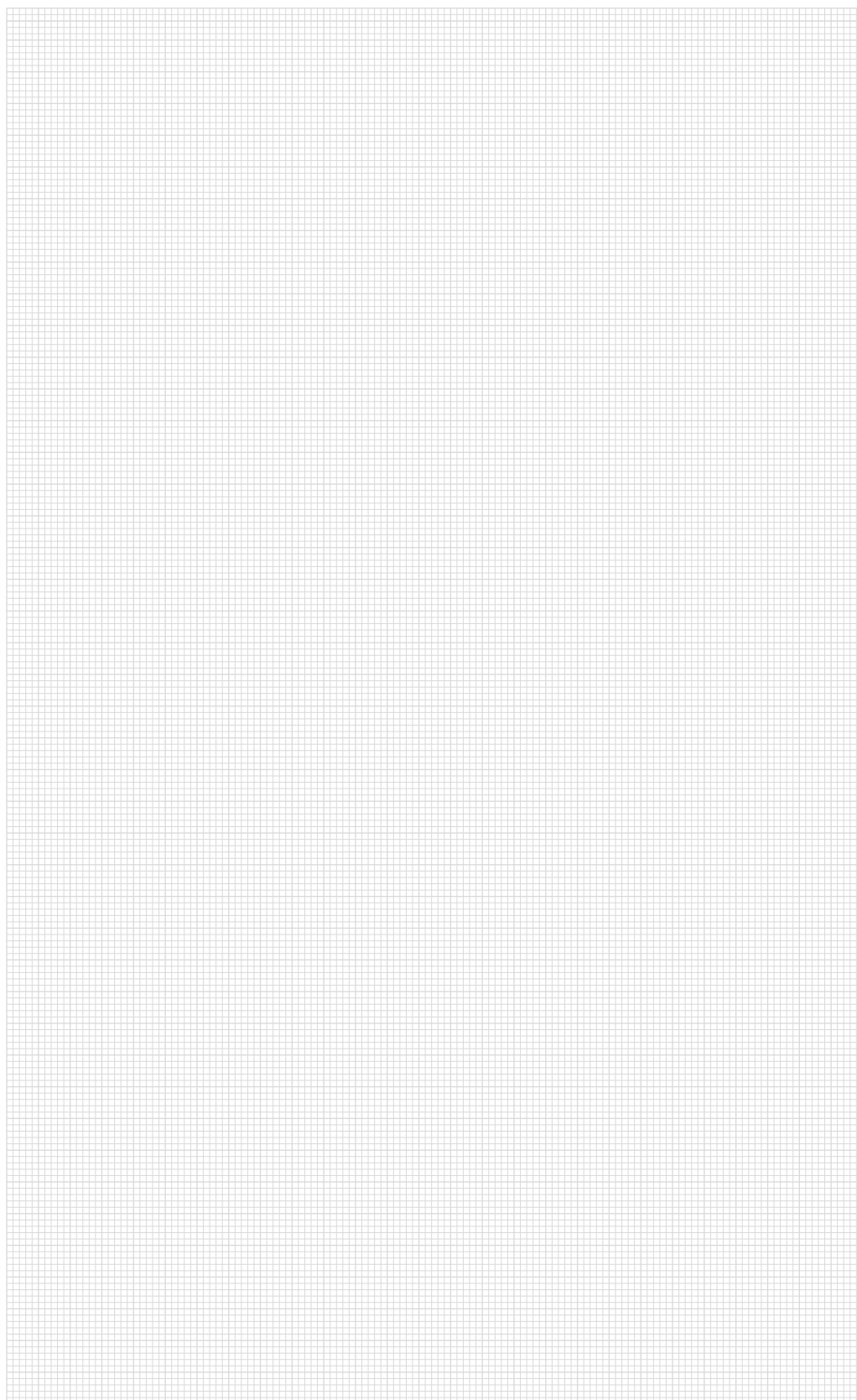
A large rectangular area filled with a fine grid pattern, intended for taking notes.

**MACO
RAIL-SYSTEMS**



**MAYER & CO
BESCHLÄGE GMBH**

Alpenstraße 173
A-5020 Salzburg

Tel.: +43 662 6196-0
E-Mail: maco@maco.eu
www.maco.eu

Created: 08/2014 - Changed: 19.08.2020

Order no. 757077EN

All rights reserved and subject to change.

This print document is revised regularly.
The latest version is available at
<https://www.maco.eu/assets/757077en>
or scan the QR code.

