

Architectural mechanical equipment

Electronic controls - SL60 Actuator



Electric actuator model SL60 with self-aligning tilting movement with rigid stem, complete with brackets and accessories for outward opening windows. Functions at 230V~50Hz, or at 24V DC. Maximum load applicable 600N. Designed for parallel connection of two or more actuators with end of stroke microswitches. Run lengths available 180 - 230 - 350 - 550 - 750 mm. The device is marked with the CE seal and complies with the following directives: CEE 89/336, CEE 73/23 and subsequent amendments.

Key Features

- Self aligning tilting movement
- Fitting accessories for top hung windows
- Available in 240v or 24v
- Adjustable strokes: 180-230-350-550-750 mm
- Preset for the connection in parallel of 2 or more actuators, with end stroke microswitches.
- Max. traction and thrust force of 600N

contact us for more details:

8.15 - 16.45 (mon-thurs)

8.15 - 13.15 (fri)

Tel: +44 (0)1268 522861

Fax: +44 (0)1268 282994

www.clearlinearchitectural.com

Kongsberg Automotive

Christopher Martin rd.

Basildon

Essex

SS14 3ES

England



ISSUE DATE: March 09

Architectural mechanical equipment

Electronic controls - SL60 Actuator

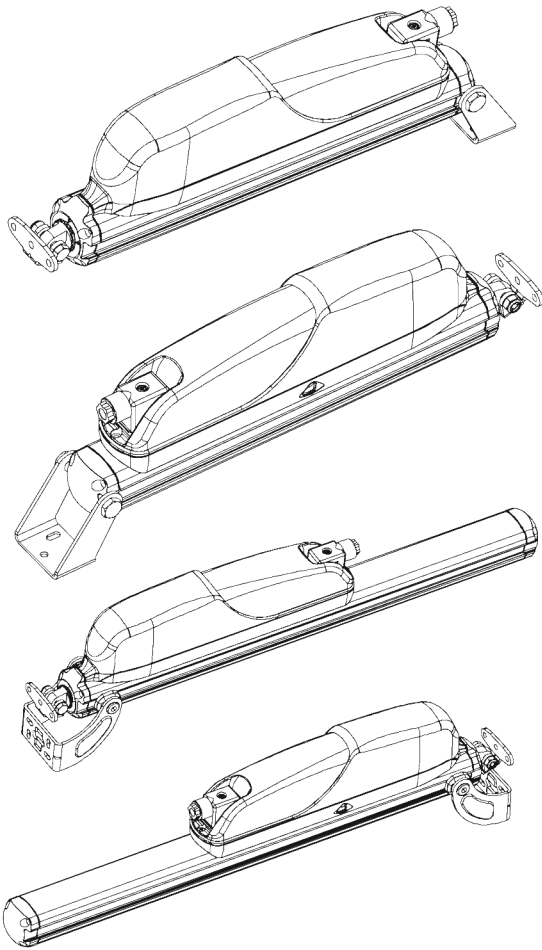

Machine composed by an electronically operated geared motor and a thrust actuator, which can be assembled, to reduce warehousing costs.



Rapid hooking system between electronically operated geared motor and thrust actuator.



Easy and fast assembly and adjustment thanks to the pathways for the connection of the strong steel support.

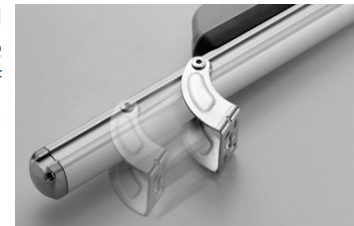

Electric parts in double insulation (no ground cable required)

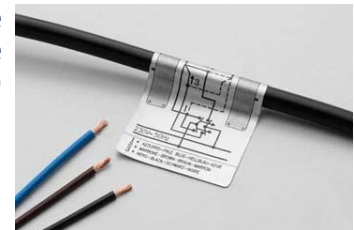

High protection degree IP 55.

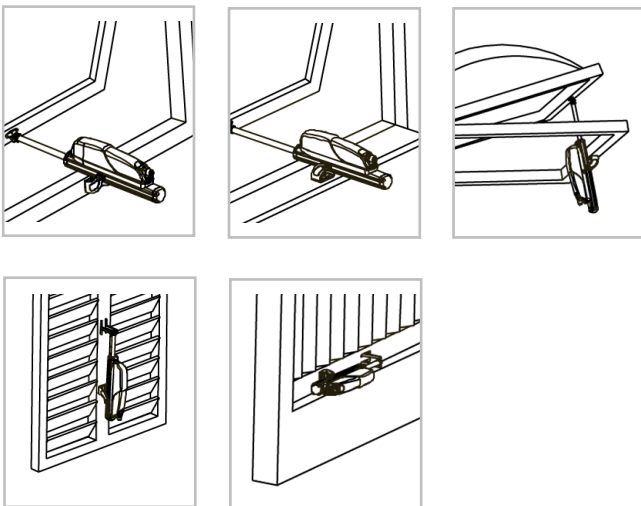

contact us for more details:

8.15 - 16.45 (mon-thurs)

8.15 - 13.15 (fri)

Tel: +44 (0)1268 522861

Fax: +44 (0)1268 282994

www.clearlinearchitectural.com

Kongsberg Automotive

Christopher Martin rd.

Basildon

Essex

SS14 3ES

England

Architectural mechanical equipment

Electronic controls - SL60 Actuator

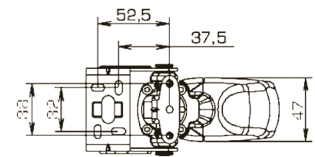
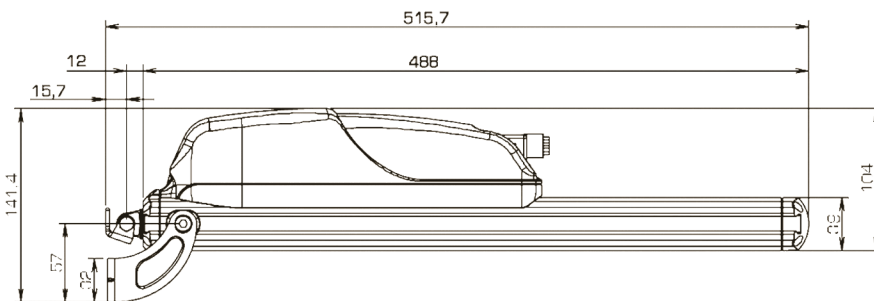
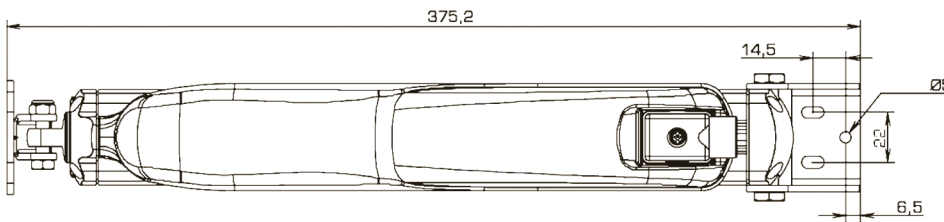
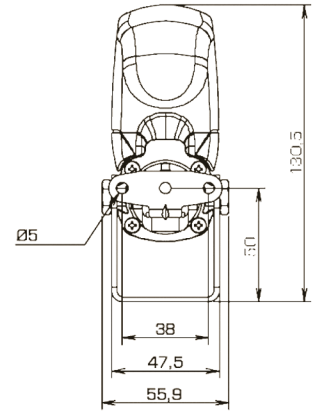
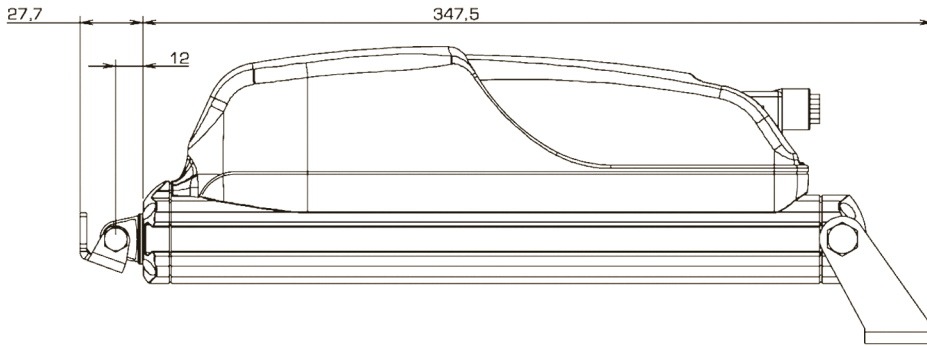

contact us for more details:

8.15 - 16.45 (mon-thurs)

8.15 - 13.15 (fri)

Tel: +44 (0)1268 522861

Fax: +44 (0)1268 282994

www.clearlinearchitectural.com

Kongsberg Automotive

Christopher Martin rd.

Basildon

Essex

SS14 3ES

England



ISSUE DATE: March 09

TeleflexMorse reserve the right to modify their products without notice including their specifications, equipment and accessories

Architectural mechanical equipment

Electronic controls - SL60 Actuator

Technical Specification - T50 Rack Actuator

	SL60/230		SL60/24
Power supply voltage	230V ~ 50 Hz		24V d.c.
Max. recommended load in thrust/traction position		600N	
Available strokes		180-230-350-550-750mm	
Rated absorbent current	0.33A		1.5A
Idle translation speed	12mm/sec		7mm/sec
Duration of the idle stroke		stroke/idle translation speed	
Double electrical insulation	yes		-
Service type		S2 of 3min	
Operating temperature		-5 + 50 °C	
Protection degree of electrical devices		IP 55	
Connection of 2 or more actuators in parallel		YES	
End of stroke		micro-switch	
Dimensions		variable from 337 to 907x47x104mm	

contact us for more details:

8.15 - 16.45 (mon-thurs)

8.15 - 13.15 (fri)

Tel: +44 (0)1268 522861

Fax: +44 (0)1268 282994

www.clearlinearchitectural.com

Kongsberg Automotive

Christopher Martin rd.

Basildon

Essex

SS14 3ES

England



ISSUE DATE: March 09