

Hardware system of modular design for stackable wooden partitions up to 100 and 150 kg (220 and 330 lbs.) per panel.

Description

Thanks to the modular track system and its unrivalled cornering technique, HAWA-Variotec 150/H enables the quick realization of all design concepts for room partitions. This hardware system allows straight top tracks/bottom guide channels and curved segments of 15, 30, 45, 60, 75 and 90 degrees to be combined to form customized configurations. Different trolleys are required depending on the door weight (100 or 150 kg / 220 or 330 lbs.).

Test certificates of the Landesgewerbeanstalt Bayern (LGA) in Nuremberg confirm the hardware system's high functionality and resistance to wear.

In principle, a version without bottom guide channels is possible. However, we recommend using them since this makes opening and closing the partitions more convenient.

Applications

This hardware system is suitable for use wherever high quality and quiet operation are called for, e.g. in hotels, restaurants, banks, open-plan offices and exclusive interior designs.

Features of the HAWA-Variotec 150/H

- Modular system
- Trolley with two-point guide
- Progressively adjustable height +6/ -3 mm ($\frac{15}{64}$ " / $\frac{1}{8}$ ")
- Extremely light and smooth cornering
- Minimum axis radius 4000 mm (13'1 $\frac{1}{2}$ ")
- Maximum sliding door weight 150 kg (330 lbs.)
- Secure locking
- Small space requirement in stacking area

Layout examples



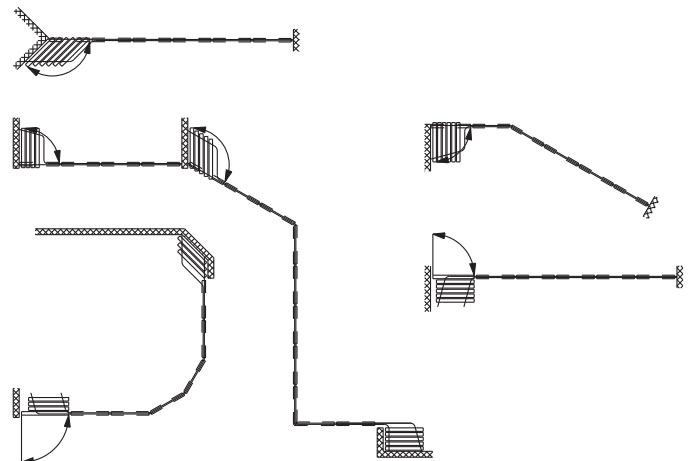

The layout examples shown below demonstrate the many varied and creative application possibilities of the HAWA-Variotec 150/H hardware system.

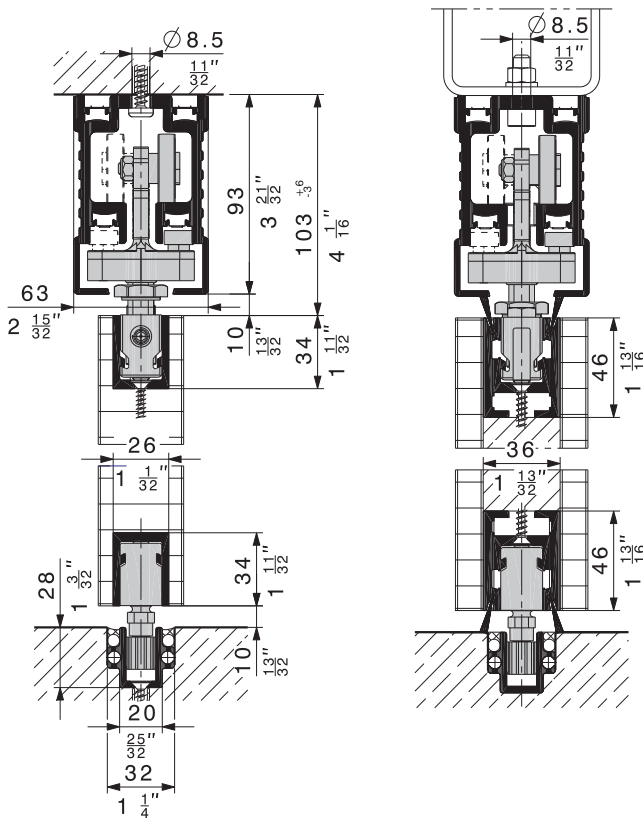
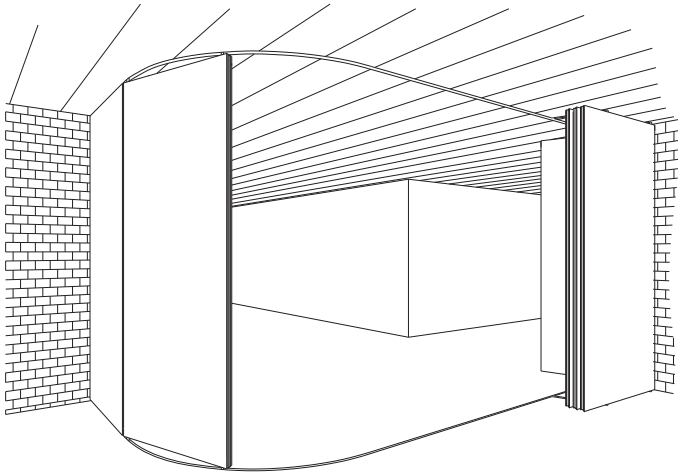



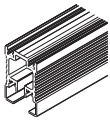
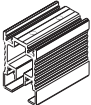



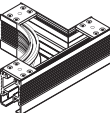
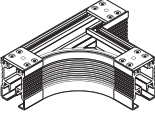



Subject to modification. Metric specifications are exact. Inches are approximate.



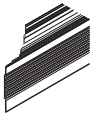



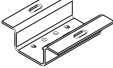

Top tracks

Caution: Hole positions vary.			code
	Single top track, alu plain anodized	6000 mm (19'8 $\frac{7}{32}$ ")	15358
		cut to size	15360
	Dual top track, alu plain anodized, predrilled	6000 mm (19'8 $\frac{7}{32}$ ")	15361
		cut to size	15362
	Servicing unit, dismantable	100 mm (3 $\frac{151}{16}$ ")	15380
	Inner curve top track, segment, alu plain anodized	15°	15377
		30°	15375
		45°	15373
		60°	15371
		75°	15369
		90°	15367
		angle according to indication	19801
	Outer curve top track, segment, alu plain anodized	15°	15376
		30°	15374
		45°	15372
		60°	15370
		75°	15368
		90°	15366
		angle according to indication	19800
	Top track dual curved segment, for changing direction, alu plain anodized	15°	15718
		30°	15719
		45°	15720
		60°	15721
		75°	15722
		90°	15723
		angle according to indication	18667
	Top track curved segment, parking area branch, parking area left, alu plain anodized	45°	17551
		60°	15845
		75°	15843
		90°	15841
	Top track curved segment, parking area branch, parking area right alu plain anodized	45°	17552
		60°	15846
		75°	15844
		90°	15842



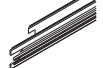



Top tracks – accessories

Caution: Hole positions vary.			code
	Cover plate for dual top track, complete		15439
	Top fixing plate for single top track		15414
	Top fixing plate for 2 x single top track		15383
	Coupler for top track, galvanized steel		17232
	Matching segment dual top track, 45°-90°, left		16173
	Matching segment dual top track, 45°-90°, right		16174
	Top track stop for single track		13779
	Top track stop for dual track		13780
	Connecting bracket for ceiling structure, without fixing parts		17045
	Assembly parts for connecting bracket for ceiling structure		19321

Bottom guide channels and accessories

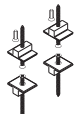
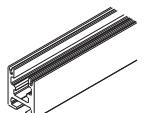
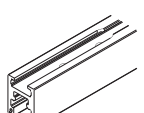
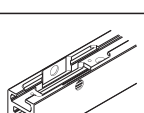
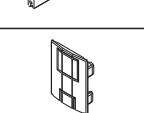
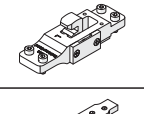
Caution: Hole positions vary.			code
	Bottom guide channel, alu plain anodized, predrilled	6000 mm (19'8 $\frac{7}{32}$ ")	13688
		cut to size	13690
	Curved bottom guide channel, alu plain anodized, predrilled	15°	13644
		30°	13647
		45°	13650
		60°	13653
		75°	13656
		90°	13659
		angle according to indication	19645
	Bottom guide channel special dual curved segment, Rm127, alu plain anodized		16778
	Matching segment bottom guide channel 45°-90°, left		16779
	Matching segment bottom guide channel 45°-90°, right		16779
	Connecting bolt, Ø 6 x 40 mm ($\frac{1}{4}$ " x 1 $\frac{19}{32}$ "), stainless steel		13759

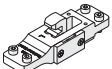
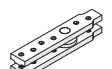
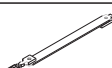
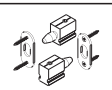
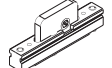
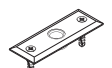
Sliding pivot door – components

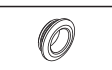
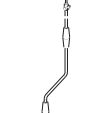
		code	
	Two-wheeled trolley, M14, with plastic-tired wheels and suspension plate [sliding pivot doors up to 90 kg (198 lbs.) and 3000 (9'10 1/8") height]	13821	
	Holding device, sliding swing door / sliding pivot door, for top tracks with integrated cover	15398	
	Stop plate complete for sliding swing door / sliding pivot door,	15429	
	Contact plate for sliding pivot door	14265	
	Suspension profile, cut to size, alu unanodized, predrilled	14232	
	Suspension profile, cut to size, alu unanodized, predrilled, for sliding pivot door, with cutout for strike plate	14260	
	Suspension profile, cut to size, alu unanodized, undrilled, for sliding pivot door, with cutout for strike plate	14261	
	Suspension profile, cut to size, alu unanodized, predrilled, for sliding pivot door, with cutout for lock	14233	
	Suspension profile, cut to size, alu unanodized, predrilled, for sliding pivot door, with cutout for deadbolt lock	14234	
	Suspension profile cover cap, plastic black	14211	
	Lock complete, for sliding pivot door	left	14213
		right	14214
	Pivot bearing, for sliding pivot door	14197	
	Door stop, for sliding pivot door	14207	
	Centering assembly for sliding pivot door	14264	
	Deadbolt lock 13 mm (17/32"), galvanized steel,, for sliding pivot door	14087	
	Strike plate/pivot bearing, chromium-plated steel	14088	
	Key for deadbolt lock, 10721, 10726, 13144	10723	
	Slip-fit rose, brass dull nickel finish	13858	
	Short connecting rod for door height up to ≤ 2500 mm (8'2 7/16")	14164	
	Long connecting rod for door height up to ≥ 2500 mm (8'2 7/16")	14165	

Door types

Different door types can be combined to accommodate customized design preferences and creative solutions



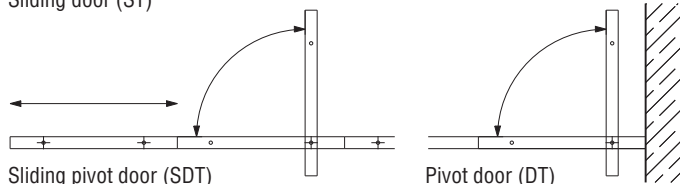

Sliding door (ST)



Sliding pivot door (SDT)

Pivot door (DT)

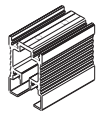
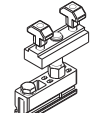
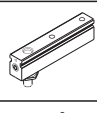
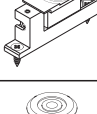
Pivot door – components



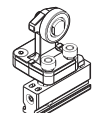
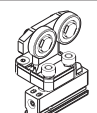
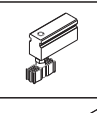
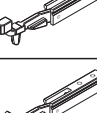
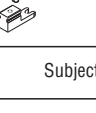

		code
	Servicing unit, dismantable, 100 mm (3 15/16")	15380
	Pivot bearing for swing door and pivot door (without top track)	16196
	Driver, vertically adjustable, for pivot door	16325
	Thrust bearing adjustable, Inox, for fitting into bottom guide channel	22299
	Thrust bearing sleeve, Ø 30 mm (1 3/16"), for pivot door	16326

Sliding door – components

		code
	Single-wheeled trolley, M14, with plastic-tired ball bearing wheels and suspension plate (for maximum sliding door weights 100 kg (220 lbs.))	13778
	Two-wheeled trolley, M14, with plastic-tired ball bearing wheels and suspension plate (for maximum sliding door weights 150 kg (330 lbs.))	13818
	Guide plastic, 14 mm (9/16")	13781
	Floor locking lever	19820
	Floor locking lever 0–18°	19822

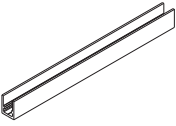
Subject to modification. Metric specifications are exact. Inches are approximate.

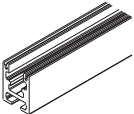
Suspension profiles and cover caps

Caution: Hole positions vary.			code
	Multi-purpose suspension and retainer profile, alu plain anodized, predrilled	cut to size	10347
	Top fixed suspension	350 mm (1'1 ²³ / ₃₂ ")	11004
	Cover cap for top fixed suspension, plastic anthracit-grey RAL 7016, for profile 10347/11004		20907
	Multi-purpose suspension and retainer profile, alu plain anodized, predrilled	cut to size	14232
	Suspension profile cover cap, plastic black, for profile 14232		14211

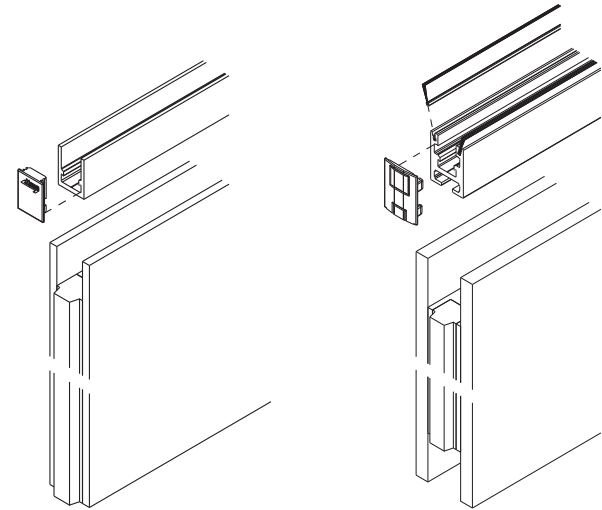

Suspension profiles and cover caps



Suspension profile: 10347 / 11004
Cover cap: 20907

Suspension profile: 14232
Cover cap: 14211
Brush seal : 16797 / 13791

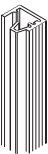
Seal profile / rubber profile

Deployment between the sliding doors			code
	Seal profile, alu plain anodized, predrilled	6000 mm (19'8 ⁷ / ₃₂ ")	14223
		cut to size	13528
	Rubber profile, black	20 m roll (65'7 ¹³ / ₃₂ ")	15340
		cut to size	13571

Panel centering

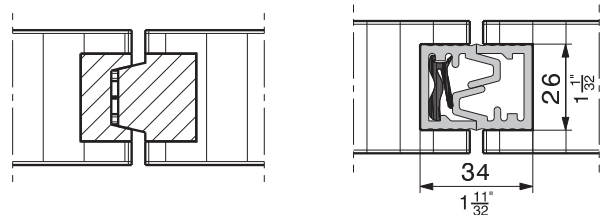

Door panels must be centred to ensure flush fitting.



Version A
With customer-supplied wooden strips

Version B
With HAWA seal profile, plain anodised aluminium (13528) including black rubber profile (13571)

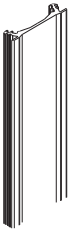
Protective edge trims / brush seal

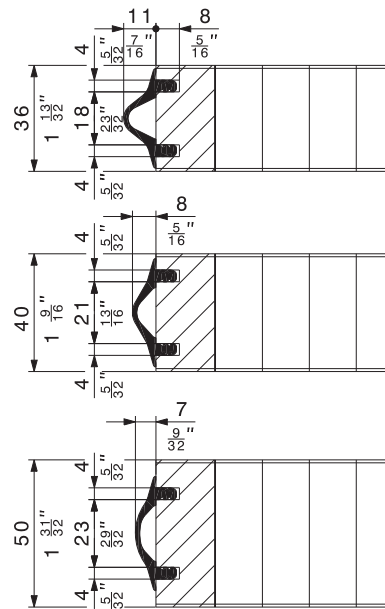

		roll	code
	HAWA-protective edge trim, black, similar RAL 7021	5 m (16'4 ²⁷ / ₃₂ ")	10626
		10 m (32'9 ²³ / ₃₂ ")	12325
	HAWA-protective edge trim, brown, similar RAL 8024	5 m (16'4 ²⁷ / ₃₂ ")	10627
		10 m (32'9 ²³ / ₃₂ ")	12326
	HAWA-protective edge trim, cream-white, similar RAL 9001	5 m (16'4 ²⁷ / ₃₂ ")	10649
		10 m (32'9 ²³ / ₃₂ ")	12327
HAWA-protective edge trim, beige, similar RAL 1001	5 m (16'4 ²⁷ / ₃₂ ")	15620	
	10 m (32'9 ²³ / ₃₂ ")	15621	
	Brush seal 2.6/18 x 920 mm (¹ / ₈ " x ²³ / ₃₂ " x 3'0 ⁷ / ₃₂ ")		16797
	Brush seal 2.6/18 x 1200mm (¹ / ₈ " x ²³ / ₃₂ " x 3'11 ¹ / ₄ ")		13791

Protective edge trims





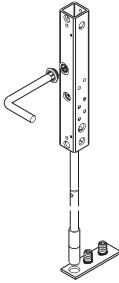
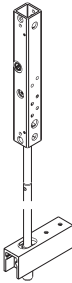
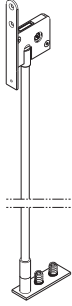
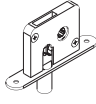

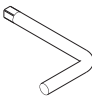

Subject to modification. Metric specifications are exact. Inches are approximate.

Locks

		code
	HAWA-Doorfix Bar bolt lock, galvanized steel Backset 18 mm ($\frac{23}{32}$ ") Socket square/hexagonal 7/8 mm Total lift of push rod: 46 mm ($1\frac{13}{16}$ ") Double turn, 1 st level 28 mm ($1\frac{11}{16}$ ") 2 nd level 18 mm ($\frac{23}{32}$ ") Operation height: 980 mm or 830 mm ($3'2\frac{19}{32}$ " or $2'8\frac{11}{16}$ "),complete Push rod can be shortened. The bar bolt lock can be operated from the door surface as well as from the front with a square/hexagonal key. Assembly dimensions: → page 80	15077
	HAWA-Doorfix Bar bolt lock, galvanized steel Backset 18 mm ($\frac{23}{32}$ ") Socket square/hexagonal 7/8 mm Total lift of push rod: 46 mm ($1\frac{13}{16}$ ") Double turn, 1 st level 28 mm ($1\frac{11}{16}$ ") 2 nd level 18 mm ($\frac{23}{32}$ ") Operation height: 980 or 830 mm ($3'2\frac{19}{32}$ " or $2'8\frac{11}{16}$ ") complete Assembly dimensions: → page 80	14188
	Bar bolt lock Backset 42.5 mm ($1\frac{11}{16}$ ") Socket square/hexagonal, 7/8 mm Total lift of push rod: 18 mm ($\frac{23}{32}$ ") Operation height: 960 mm ($3'1\frac{13}{16}$ ") complete The bar bolt lock can be operated from the door surface with a square/hexagonal key.	19592
	Dead bolt lock, galvanized steel, 13 mm ($\frac{17}{32}$ ") Backset 29.5 mm ($1\frac{5}{32}$ ") Socket square/hexagonal 7/8 mm	10726
	HAWA-bar bolt lock, 13 mm ($\frac{17}{32}$ ") Galvanized steel Backset 34.5 mm ($1\frac{11}{32}$ ")	profile cylinder 17 mm ($\frac{11}{16}$ ") 16695 round cylinder 22 mm ($\frac{7}{8}$ ") 16696 square/hexagon socket 7/8 mm 16697
	Bar bolt lock, with guide pin	profile cylinder 17 mm ($\frac{11}{16}$ ") 18478 round cylinder 22 mm ($\frac{7}{8}$ ") 18479 square/hexagon socket 7/8 mm 18388
		Bar bolt lock with retention pin
Bar bolt lock with guide pin and fixing parts		
	Pivot bearing or deadbolt lock 13 mm ($\frac{17}{32}$ "), galvanized steel, for sliding pivot door	

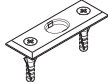
Locks – accessories

		code
	Key for deadbolt lock to 10721, 10726, 13144	10723
	Thumbturn, chromium finish for panel thickness 35 to 40 mm ($1\frac{3}{8}$ " to $1\frac{19}{32}$ ")	13789
	Thumbturn, chromium finish for panel thickness 41 to 57 mm ($1\frac{5}{8}$ " to $2\frac{1}{4}$ ")	19806
	Floor-mounted sleeve, dull chromium-plated brass	13858
	Strike plate, chromium-plated steel	13130
	Floor-mounted sleeve with oblong hole and chromium plated brass spring cover, Ø 36 mm ($1\frac{7}{16}$ ")	13787
	Rosette for floor-mounted sleeve 13787	17326

Example 1: Locking at handle height

Bar bolt lock code 19592 allows locking the sliding door at handle height.

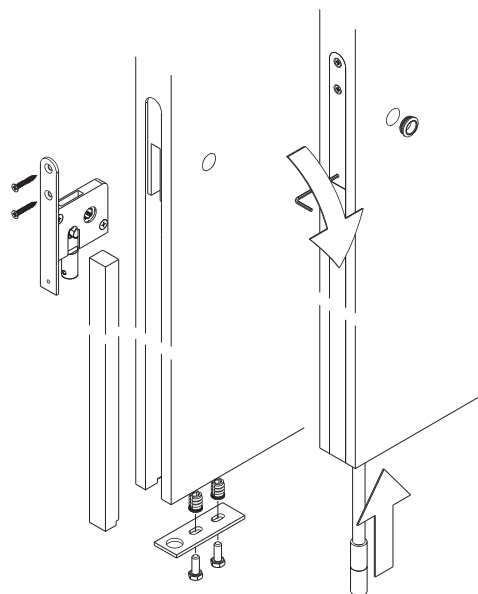
Example 2: Floor locking

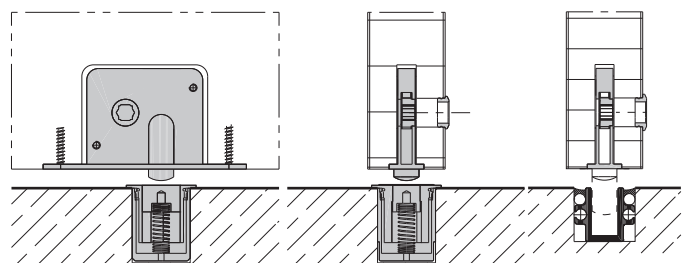

The deadbolt lock code 10726 provides unobtrusive, barely visible locking at the panel bottom edge.



Locking with floor-mounted sleeve code 13787

Locking with bottom guide channel

Tools

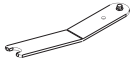
		code
	Fork spanner SW 22/12/13 mm ($\frac{7}{8}$ / $\frac{15}{32}$ / $\frac{17}{32}$), pivot door vertical adjustment	15409
	Fork spanner SW 17/8/13 mm ($\frac{11}{16}$ / $\frac{5}{16}$ / $\frac{17}{32}$)	15459
	Wrench, hexagon 5 mm ($\frac{7}{32}$), SW 11 mm ($\frac{7}{16}$)	17110

Services

	code
Cutout, bar bolt lock for 17 mm ($\frac{11}{16}$), 22 mm ($\frac{7}{8}$), square/hexagon socket	22985
Cutout in suspension profile for bar bolt lock	14241
Cutout for holding device for top tracks with integrated cover	15421

Quote preparation and design

We require the following details to prepare a quote and design version for you:

- Clearance dimensions
- Quantity of sliding doors
- Quantity of pivot doors
- Quantity of sliding pivot doors
- Door width
- Door height
- Door thickness

Order specifications

- Quantity and type of components for sliding doors, pivot doors and sliding pivot doors
- Quantity, type and length of top track
- Quantity and type of top track accessories
- Quantity, type and length of bottom guide channel
- Quantity and type of bottom guide channel accessories
- Quantity and length of seal profile
- Quantity and length of rubber profile
- Quantity, type and length of HAWA-protective edge trim
- Quantity and type of locks
- Quantity and type of lock accessories

Planning / installation

For planning and installation purposes, please use the installation drawing code 21718 (parallel) or 21719 (90°)
 (→ www.hawa.ch → HAWA-Productfinder)