

Modular hardware system for elegant all-glass sliding walls weighing up to 100 or 150 kg (220 or 330 lbs.) per panel.

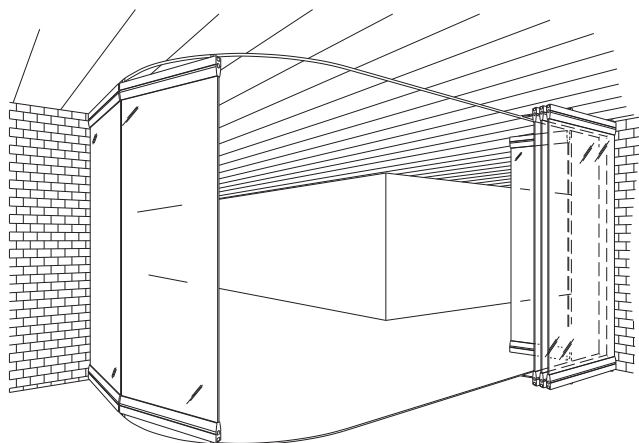

Example of application

- Sliding door
- Standard profile
- Bar bolt lock
- Closure in bottom sleeve
- Glass ESG¹

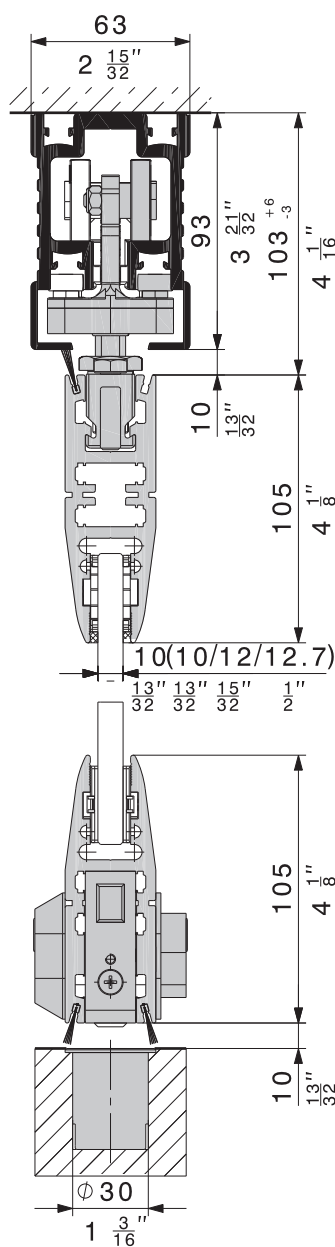

Description

The HAWA-Variotec 150/GV is a hardware system with outstanding running properties around curved structures. Thanks to a trolley with 2-point suspension, glass sliding walls can be moved extremely quietly and smoothly along curved tracks. With its advanced technology, it is also regarded as unique among sliding hardware systems. Sliding revolving doors and sliding swinging doors can be integrated at any desired point. This system ensures that you can quickly and easily provide ideal complete solutions, including fixed glass for room separation.

Applications

This hardware system is suitable for use wherever high quality, elegance and quiet operation are called for, e.g. in shopping centres, hotels, restaurants, banks, airports, railway stations, industrial premises, winter garden, administrative buildings, etc.

Features of the HAWA-Variotec 150/GV

- Modular system
- Trolley with 2-point guide wheels
- Progressive vertical adjustment (+6/-3 mm)
- Extremely smooth and quiet cornering
- Elegant top-fixed suspension and glass retainer
- Precision glazing
- Minimum axis radius, 4000 mm (13'1 $\frac{1}{2}$ ")
- All components installed in profile
- Secure locking mechanism
- Minimal space requirement in stacking area
- Top track with facing

Glass cutouts

Both glass ESG¹ and VSG² can be used.

- Glass thickness sliding door ESG¹: 10/12/12,7 mm ($\frac{13}{32}$ / $\frac{15}{32}$ / $\frac{15}{32}$ / $\frac{1}{2}$ "), thickness tolerance $\pm 0,3$ mm
- Glass thickness sliding door VSG²:
 2x5 $\pm 0,2$ mm \rightarrow film thickness 0,76 / 1,52 mm
 2x6 $\pm 0,2$ mm \rightarrow film thickness 0,38 / 0,76 mm
- All glass edges are seamed; maximum 1 mm ($\frac{1}{16}$ ") in the glass cutout
- VSG² permissible with max. offset of 2 mm ($\frac{3}{32}$ ") in the glass cutout

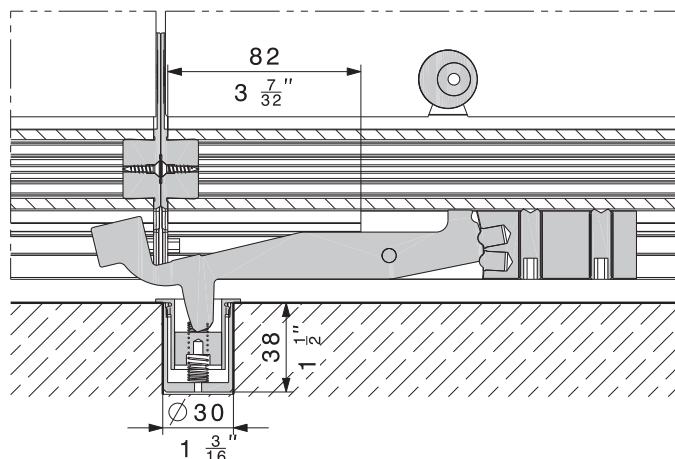

¹ fully tempered monolithic glass

² fully tempered laminated glass

Subject to modification. Metric specifications are exact. Inches are approximate.

Further examples of application

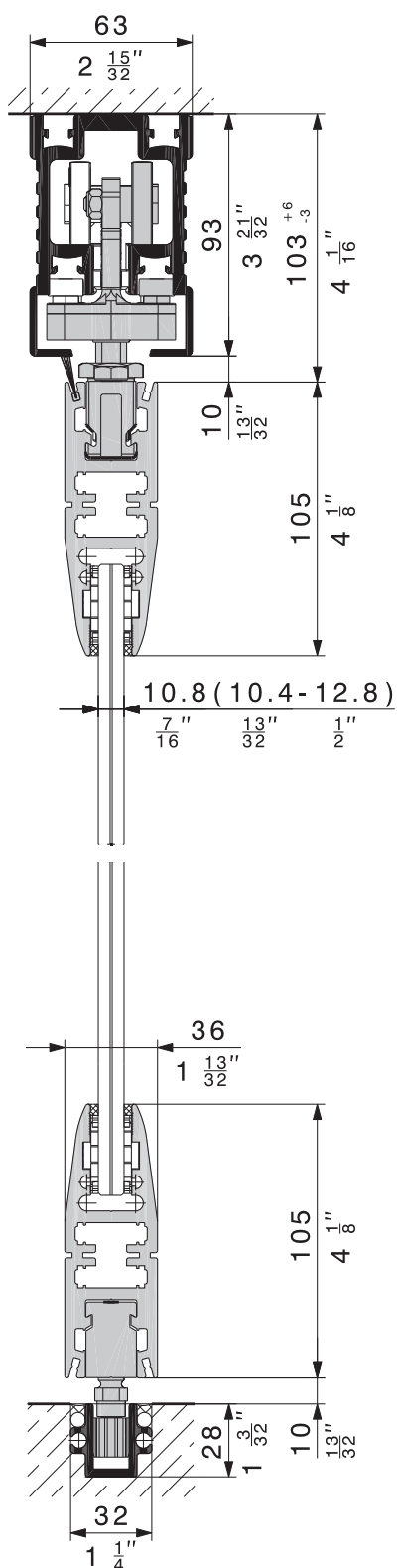

- Sliding door
- Standard profile
- Guide slider in bottom guide channel
- Without locking mechanism
- Glass VSG²

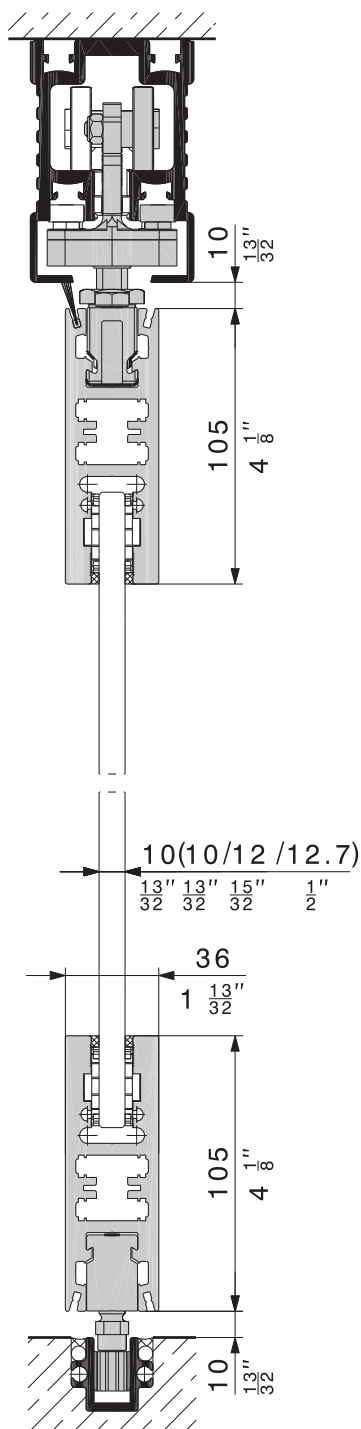

- Sliding door
- Straight profile, 105 mm (4 5/8")
- Guide slider in bottom guide channel
- Without locking mechanism
- Glass ESG¹

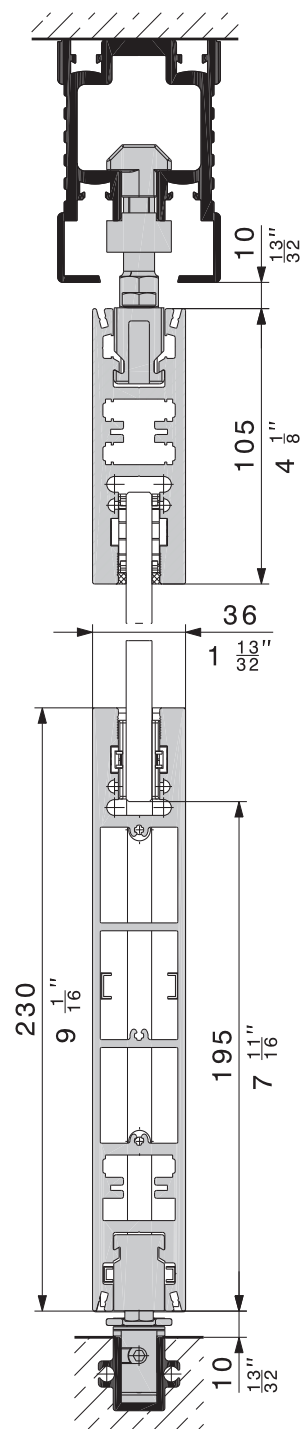

- Pivot door
- Top, straight profile, 105 mm (4 5/8")
- Bottom, straight profile, 230 mm (9 1/16")
- Without locking mechanism
- Glass ESG¹

Layout examples

The layout examples shown here clearly demonstrate the flexibility of the HAWA-Variotec 150/GV, as well as the creative potentials it offers. This system permits the use of fixed glass fittings, swinging doors, sliding swinging doors and curved installations, etc. Each track can be customized on request for almost every curvature radius. The minimum axis radius for curved all-glass sliding walls is 4000 mm (13'1 1/2").

Countless floor plans – 4 examples:

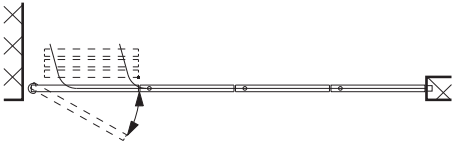

Straight installation with parallel stacking and pivot door

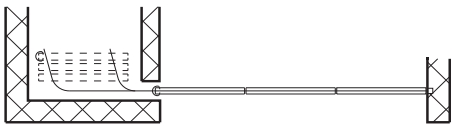

Straight installation with parallel stacking and locking door

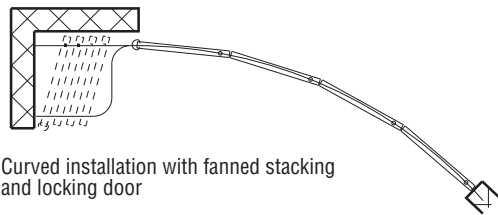

Curved installation with fanned stacking and locking door

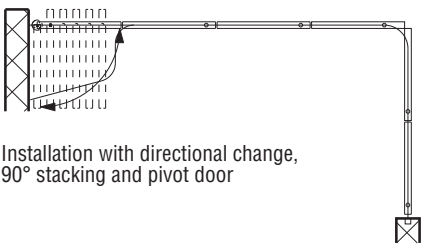

Installation with directional change, 90° stacking and pivot door

Space-saver

The mobility of HAWA-Variotec 150/GV makes it possible to save a considerable amount of space. It can stack doors in even the tiniest of spaces. Layout options are limitless thanks to two cover cap designs.

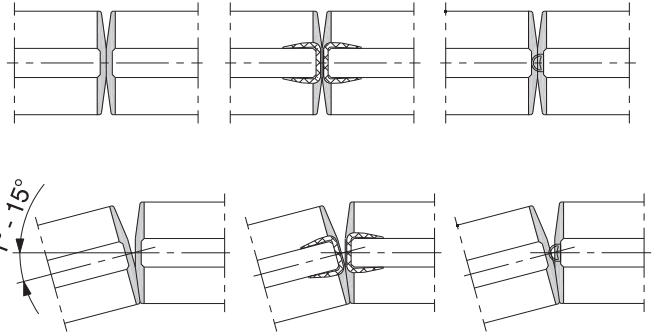

Straight and curved installations, and installations with a directional change of up to 15°, can be implemented using the standard cover cap 19903

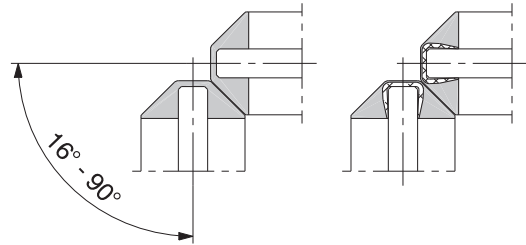

Cover cap 13587 is required for installations with directional changes between 16° and 90°

Door types

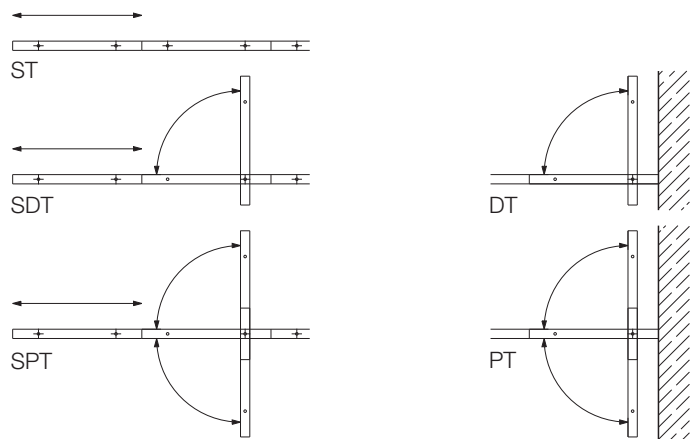

ST	Sliding door
SDT	Sliding pivot door
SPT	Sliding swing door
DT	Pivot door
PT	Swing door

Subject to modification. Metric specifications are exact. Inches are approximate.

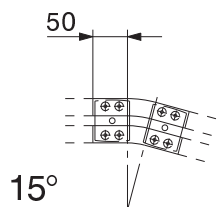

Cornering technology

With this sliding-door hardware system it is possible for straight top tracks with integrated facing and curved sections with or without interior facing to be assembled in combinations of 15, 30, 45, 60, 75 and 90 degrees according to individual requirements. Special customized versions can also be provided. The minimum radius is 4000 mm (13'1 1/2"). This flexibility permits simple storage, as well as planning and modifications at short notice.

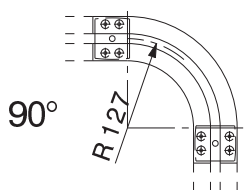
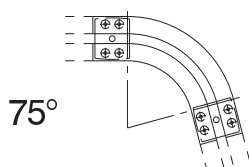
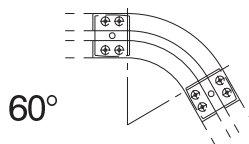
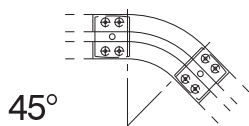
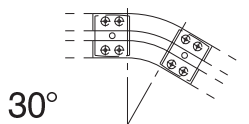

Parking area with concealed interior

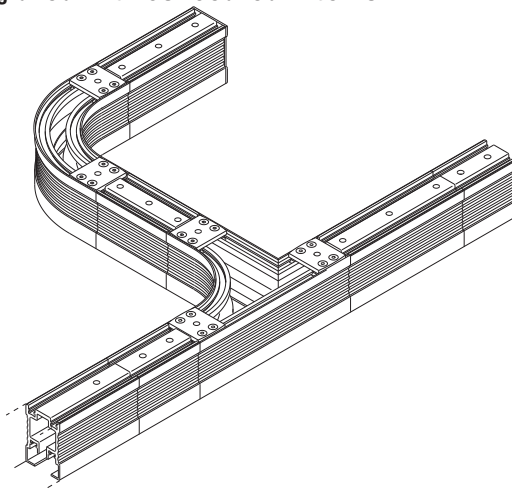

Parking area without concealed interior

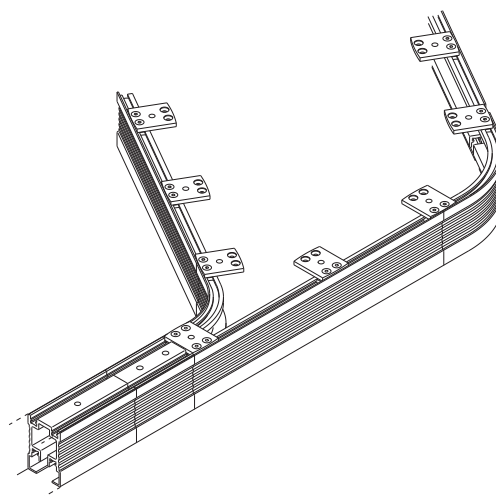

Connecting bracket for ceiling structure

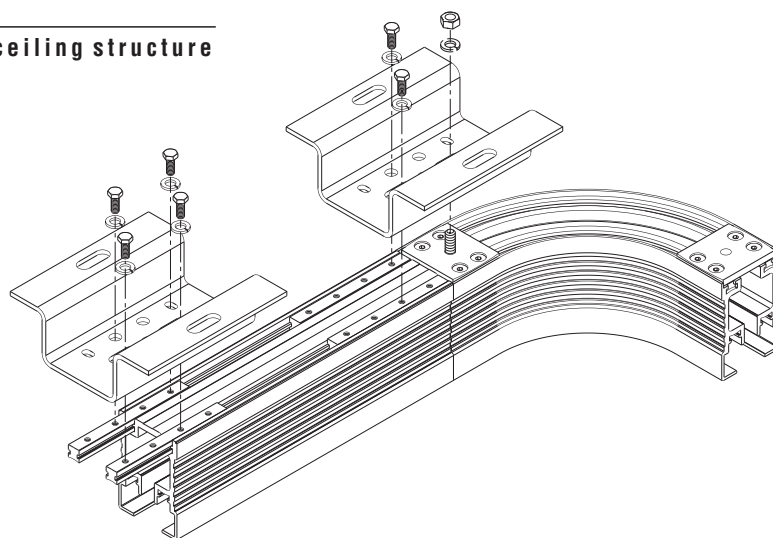

Glass retention eccentric

A glass retention eccentric with side wedge permits optimum and simple attachment of the glass. Before installation, the glass ESG¹ or VSG² have to be prepared with cutouts.

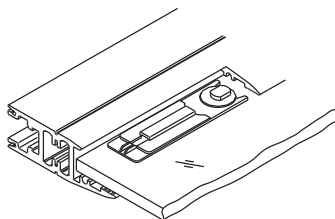

Seals and glass edge protection

The system permits the integration of horizontal and vertical seals; these can also be fitted retrospectively. A transparent glass edge protection profile and the self-adhesive rubber profile are recommended to protect vertical glass edges. The latter not only protects the glass edge, but also reduces draughts to a minimum.

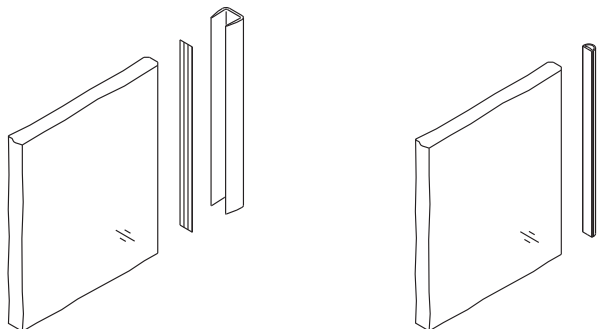

The glass edge protection profile is made of transparent plastic and is fitted to the glass edge with double-sided adhesive tape.

The self-adhesive rubber profile in black or translucent reduces draughts to a minimum and protects the glass edge.

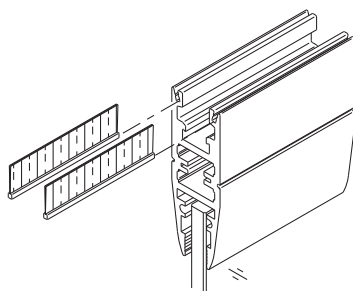

The horizontal brush seal is inserted into the suspension profile and protects against draughts.

Glass suspension and retainer profile

Unobtrusive operating elements such as locks, top-fixed suspension and guide plates are integrated into the profile. The only visible component is a glass retainer which is of highly attractive design.

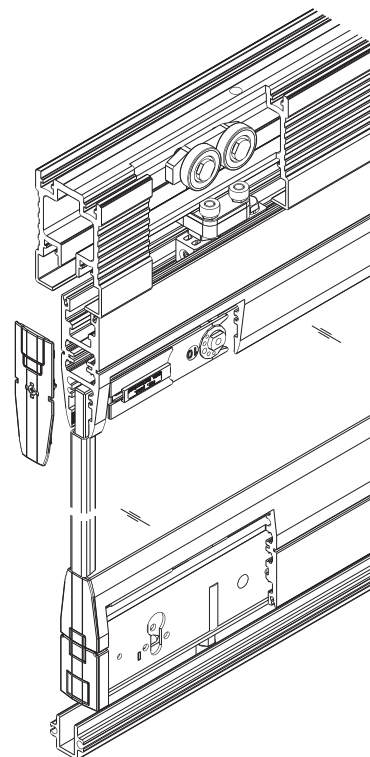

Better safe than sorry

One- or two-bolt safety lock is available for securing all-glass sliding doors: single-turn with toughened bars and 20 mm ($\frac{25}{32}$ " feed, cylinder aperture 17 mm ($\frac{11}{16}$ " or 22 mm ($\frac{7}{8}$ "), or with square/hexagon socket. Closure in bottom sleeve with spring-loaded cover or in the bottom guide channel.

Accessories

Item codes and parts illustrations: → next pages.

Order specifications

(Layout sketches of closed wall and available stacking space, with dimensions)

- Vertical cross-section of upper and lower situation
- Length and height of complete glass front
- Door width
- Door height
- Thickness of glass
- Type of stacking
- Quantity of sliding doors
- Quantity of pivot doors
- Quantity of swing doors
- Quantity of sliding pivot doors
- Quantity of sliding swing doors
- Type of glass protective edge profile

Order specifications











Please contact us for planning and installation documentation. (→ www.hawa.ch → Systemplanner)

¹ fully tempered monolithic glass

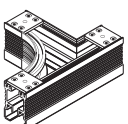
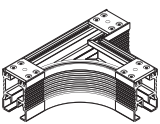

² fully tempered laminated glass

Subject to modification. Metric specifications are exact. Inches are approximate.

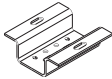

Top tracks

			code		
	Single top track, alu plain anodized	6000 mm (19'8 ⁷ / ₃₂ ")	15358		
		cut to size	15360		
	Dual top track, alu plain anodized, predrilled	6000 mm (19'8 ⁷ / ₃₂ ")	15361		
		cut to size	15362		
	Servicing unit, dismantable	100 mm (3 ¹⁵ / ₁₆ ")	15380		
	Cover plate for dual top track, alu plain anodized		15439		
	Inner curve top track, alu plain anodized	15°	15377		
		30°	15375		
		45°	15373		
		60°	15371		
		75°	15369		
		90°	15367		
	Inner top track special curved segment Rm127, alu plain anodized	angle according to indication	19801		
	Outer curve top track, alu plain anodized	15°	15376		
		30°	15374		
		45°	15372		
		60°	15370		
		75°	15368		
		90°	15366		
			Outer top track special curved segment Rm127, alu plain anodized	angle according to indication	19800
	Top track dual curved segment, for change in direction, alu plain anodized	15°	15718		
		30°	15719		
		45°	15720		
		60°	15721		
		75°	15722		
		90°	15723		
			Top track-special dual curved segment Rm127, alu plain anodized	angle according to indication	18667
			Top track curved segment, parking area branch, parking area left, alu plain anodized	45°	17551
60°	15845				
75°	15843				
90°	15841				
	Top track curved segment, parking area branch, parking area right, alu plain anodized	45°	17552		
		60°	15846		
		75°	15844		
		90°	15842		
	Top-fixing plate, alu plain anodized		15414		
	Top-fixing plate, galvanized steel, for welding		15383		
	Coupler to top track, gavanized steel		17232		

Connectin bracket for ceiling structur

		code
	Connectin bracket for ceiling structur, without fixing parts	17045
	Assembly parts for connecting bracket for ceiling structure	19321



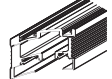

Track stops

		code
	Top track stop complete, for single top track	13779
	Top track stop complete, for dual top track	13780

Matching segment for dual top track

		code
	Matching segment for dual top track 45°-90° left	16173
	Matching segment for dual top track 45°-90° right	16174

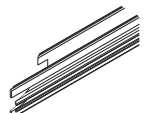
Bottom guide channels

			code
	Bottom guide channel, alu plain anodized, predrilled	6000 mm (19'8 ⁷ / ₃₂ ")	13688
		cut to size	13690
	Curved bottom guide channel, alu plain anodized, predrilled	15°	13644
		30°	13647
		45°	13650
		60°	13653
		75°	13656
		90°	13659
			Bottom guide channel special curved segment Rm127, alu plain anodized
	Matching segment for bottom guide channel 45°-90°	left	16778
		right	16779
	Grooved dowel pin, gavanized steel		13759

Subject to modification. Metric specifications are exact. Inches are approximate.

Glass suspension and retainer profiles

		mm/inch	code
	Glass suspension and retainer profile, alu unanodized	6500 (21'3 ²⁹ / ₃₂)	13576
		cut to size	13681
	Glass suspension and retainer profile, alu unanodized (straight profile)	6500 (21'3 ²⁹ / ₃₂)	23441
		cut to size	23442
	Glass suspension and retainer profile, alu unanodized, incl. lock cutout	1070 (3'6 ¹ / ₈)	17300
	Glass suspension and retainer profile, alu unanodized, incl. lock cutout (straight profile)	1070 (3'6 ¹ / ₈)	23477
	Glass suspension and retainer profile, alu plain anodized, brushed	6500 (21'3 ²⁹ / ₃₂)	16669
		cut to size	19868
Installations with sliding swing and sliding pivot doors cannot be carried out with anodized profiles ex stock.			
	Glass suspension and retainer profile, alu plain anodized, brushed (straight profile)	6500 (21'3 ²⁹ / ₃₂)	23440
		cut to size	23443
	Glass suspension and retainer profile, alu unanodized, height 230 mm	4500 (14'9 ³ / ₁₆)	19180
		cut to size	19066
	Suspension profile, alu unanodized	6500 (21'3 ²⁹ / ₃₂)	13682
		cut to size	13683
	Suspension profile, alu plain anodized, brushed	6500 (21'3 ²⁹ / ₃₂)	21833
		cut to size	21834
	Glass suspension profile, alu unanodized	6500 (21'3 ²⁹ / ₃₂)	13684
		cut to size	13685
	Glass suspension profile, alu plain anodized, brushed	6500 (21'3 ²⁹ / ₃₂)	21835
		cut to size	21836
	Glass suspension profile, alu unanodized (straight profile)	6500 (21'3 ²⁹ / ₃₂)	23445
		cut to size	23446
	Glass suspension profile, alu plain anodized, brushed (straight profile)	6500 (21'3 ²⁹ / ₃₂)	23503
		cut to size	23504
	Set of glass fixing parts, for 1 sliding door (4 pieces)	ESG ¹ 10 mm (¹³ / ₃₂)	13900
		ESG ¹ 12 mm (¹⁵ / ₃₂)	13901
		ESG ¹ 12,7 mm (¹ / ₂)	13902
	Set of glass fixing parts, for 1 sliding door (4 pieces)	VSG ² 2x5 mm (¹ / ₃₂)	21263
		VSG ² 2x6 mm (¹ / ₄)	23542
	Fork spanner to glass holder insert		13817
	Installation tool for blocking keys 10/12/12.7 mm (¹³ / ₃₂ / ¹⁵ / ₃₂ / ¹ / ₂) glass		13710

Safety locks

		mm/inch	code
	One-bolt safety lock	profile cylinder 17 mm (¹¹ / ₁₆)	13856
		round cylinder 22 mm (⁷ / ₈)	13857
		square/hexagon socket 7/8 mm	13855
	Two-bolt safety lock	profile cylinder 17 mm (¹¹ / ₁₆)	13785
		round cylinder 22 mm (⁷ / ₈)	13786
		square/hexagon socket 7/8 mm	13784
	One-bolt safety lock with bottom guide pin	profile cylinder 17 mm (¹¹ / ₁₆)	13999
		round cylinder 22 mm (⁷ / ₈)	14000
		square/hexagon socket 7/8 mm	14076
	Bar bolt lock, with retention pin, stainless steel WNR 1.4301/AISI 304	profile cylinder 17 mm (¹¹ / ₁₆)	21225
	Thumbturn, chromium finish, with square pin 7 x 25 mm (⁹ / ₃₂ x ³¹ / ₃₂)		13789
	Security rose 12 mm (¹⁵ / ₃₂), for profile cylinder 17 mm (¹¹ / ₁₆), chromium-nickel steel		14147
	Floor-mounted sleeve with oblong hole and chromium-plated brass spring		13787
	Rosette for floor-mounted sleeve 13787		17326
	Strike plate, chromium-plated steel		13130

Protective transparent edge trims

		glass	mm/inch	code
	Protective transparent edge profile, plastic	10 mm (¹³ / ₃₂)	3000 (9'10 ¹ / ₈)	13822
			6000 (19'8 ⁷ / ₃₂)	13600
		12 mm (¹⁵ / ₃₂)	3000 (9'10 ¹ / ₈)	13908
			6000 (19'8 ⁷ / ₃₂)	13907
		12,7 mm (¹ / ₂)	3000 (9'10 ¹ / ₈)	13912
			6000 (19'8 ⁷ / ₃₂)	13911
	Rubber profile self-adhesive, for 8/10 mm (⁵ / ₁₆ / ¹³ / ₃₂) glass thickness, glass distance 4 mm (⁵ / ₃₂)	black	5 m roll (16'4 ²⁷ / ₃₂)	19442
			10 m roll (32'9 ²³ / ₃₂)	19443
			50 m roll (164'0 ¹ / ₂)	19444
		translucent	5 m roll (16'4 ²⁷ / ₃₂)	19445
			10 m roll (32'9 ²³ / ₃₂)	19446
			50 m roll (164'0 ¹ / ₂)	19447

Brush seals



















		mm/inch	code
	Double-sided adhesive tape for protective transparent edge profile	50 m roll (164'0 ¹ / ₂)	13988
	Brush seal 2.6/18 mm (¹ / ₈ / ²³ / ₃₂)	920 mm (3'0 ⁷ / ₃₂)	16797
		1200 mm (3'11 ¹ / ₄)	13791

¹ fully tempered monolithic glass









² fully tempered laminated glass

Subject to modification. Metric specifications are exact. Inches are approximate.

Components for sliding door













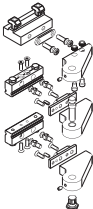

		code
	Single-wheeled trolley, M14, with plastic-tired wheel and suspension plate (sliding doors up to 100 kg [220 lbs.])	13778
	Two-wheeled trolley, M14, with plastic-tired wheels and suspension plate (sliding doors up to 150 kg [330 lbs.])	13818
	Guide, rattle proof, with plastic slider 13 mm ($\frac{17}{32}$) and suspension block	13781
	Centering piece, single unit, alu plain anodized	19818
	Centering assembly 0–18°	16629
	Centering assembly 15°–90° complet	17599
	Centering assembly 15°–90° complet (straight profile)	23516
	Centering assembly with pivot	18271
	Cover cap, incl. fixing screw	black 19903
	Cover cap, incl. fixing screw (for straight profile)	black 23470
	Cover cap for 230 mm ($9\frac{1}{16}$) tall profile	black 19884
	Cover cap for 230 mm ($9\frac{1}{16}$) tall profile, matches floor locking lever and centering assembly	black 19885
	Suspension profile cover cap, plastic	black 13585
	Glass suspension profile cover cap, plastic	black 13586
	Glass suspension profile cover cap, plastic (for straight profile)	black 23437
	Cover cap complete for door performing change in direction	black 13587
	Cover cap complete for door performing change in direction (for straight profile)	black 23471
	Cover cap for 230 mm ($9\frac{1}{16}$) tall profile, for changes in direction	black 19886

Components for sliding door











		code	
	Deadbolt lock 13 mm ($\frac{17}{32}$), with guide pin, galvanized steel	14171	
	Deadbolt lock	galvanized steel	14087
		inox	17130
	Thumbturn, alu plain anodized, with square pin 7x25 mm ($\frac{9}{32}$ x $\frac{31}{32}$)	13789	
	Floor locking lever	19820	
	Floor locking lever 0–18°	19822	
	Bottom locking device 18°–90°, left, lateral operation (HAC)	20608	
	Bottom locking device 18°–90°, right, lateral operation (HAC)	20609	
	Fork spanner SW 17/8/13 for trolley 70 kg (154 lbs.)	15459	
	Fork spanner SW 22/12/13 for trolley 100–150 kg (220–330 lbs.)	15409	
	Wrench, hexagon 5 mm ($\frac{7}{16}$), SW 11 mm ($\frac{7}{16}$)	17110	

Subject to modification. Metric specifications are exact. Inches are approximate.



















Components for pivot door

		code	
	Servicing unit, dismountable, 100 mm (3 ¹⁵ / ₁₆)	15380	
	Top pivot, without track element	16196	
	Carrier, adjustable vertically, for pivot door	16325	
	Thrust bearing, adjustable, (with bottom guide channel)	22299	
	Thrust bearing sleeve, Ø 30 mm (1 ³ / ₁₆) for pivot door	16326	
	Pivot door catch complete	17897	
	Exterior pivot bearing	16798	
	Cover cap, incl. fixing screw	black	19903
	Cover cap, incl. fixing screw (for straight profile)	black	23470
	Suspension profile cover cap, plastic	black	13585
	Glass suspension profile cover cap, plastic	black	13586
	Glass suspension profile cover cap, plastic (for straight profile)	black	23437
	Cover cap complete for door performing change in direction	black	13587
	Cover cap complete for door performing change in direction (for straight profile)	black	23471





Components for swing door

		code	
	Servicing unit, detachable, pivot fixing	15380	
	Top pivot, without track element	16196	
	Driver for swing door with commercial bottom door closer	13276	
	Cover cap, incl. fixing screw	black	19903
	Cover cap, incl. fixing screw (for straight profile)	black	23470
	Suspension profile cover cap, plastic	black	13585
	Glass suspension profile cover cap, plastic	black	13586
	Glass suspension profile cover cap, plastic (for straight profile)	black	23437
	Cover cap complete for door performing change in direction	black	13587
	Cover cap complete for door performing change in direction (for straight profile)	black	23471











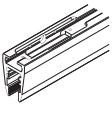
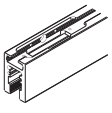

Components for sliding pivot door

		code	
	Two-wheeled trolley, M14, with plastic-tired wheels and suspension plate (sliding pivot doors up to 90 kg [198 lbs.] and 3000 [9'10 ¹ / ₈ "] height)	13821	
	Holding device	15398	
	Stop plate	15429	
	Suspension profile 1100 mm (3'7 ⁵ / ₁₆ "), with cutout, alu unanodized	13868	
	Glass suspension profile 1100 mm (3'7 ⁵ / ₁₆ "), with cutout, alu unanodized	left	13861
		right	13862
	Lock complete	left	13823
		right	13824
	Pivot bearing, galvanized steel	13827	
	Cover cap, incl. fixing screw	black	19903
	Cover cap, incl. fixing screw (for straight profile)	black	23470
	Suspension profile cover cap, plastic (top)	black	14211
	Suspension profile cover cap, plastic (bottom)	black	13585
	Glass suspension profile cover cap, plastic	black	13586
	Glass suspension profile cover cap, plastic (for straight profile)	black	23437
	Deadbolt lock	galvanized steel	14087
		inox	17130
	Strike plate, chromium-plated steel	14088	
	Hexagon key with plastic T-handle, 8/80 mm (⁵ / ₁₆ " / 3 ⁵ / ₃₂ ")	13894	
	Short connecting rod for door height up to 2500 mm (8'2 ⁷ / ₁₆ ")	14164	
	Long connecting rod for door height over 2500 mm (8'2 ⁷ / ₁₆ ")	14165	
	Surface-mounted top door closer GEZE TS 3000V with slide rail TS 5000	15515	

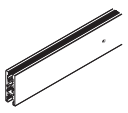







Components for sliding pivot door

		code
	Limit stop and baseplate to surface-mounted top door closer	15457
	Limit stop and baseplate to surface mounted top door closer (for straight profile)	24470
	Limit stop to surface-mounted top door closer	15451
	Locking unit for surface-mounted top door closer	15516
	Opening limiter for mounted top door closer	15517
	Instruction	14074

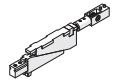
Components for sliding swing door

		code	
	Single-wheeled trolley, M14, with plastic-tired wheels and suspension plate (sliding swing doors up to 90 kg [198 lbs.] and 3000 [9'10 ¹ / ₈ "] height)	13820	
	Holding device	15398	
	Stop plate	15429	
	Suspension profile 1100 mm (3'7 ⁵ / ₁₆ "), with cutout, alu unanodized	13868	
	Suspension profile 1100 mm (3'7 ⁵ / ₁₆ "), with cutout, alu plain anodized, brushed	21837	
	Glass suspension profile 1100 mm (3'7 ⁵ / ₁₆ "), with cutout, alu unanodized	left	13861
		right	13862
	Glass suspension profile, 1100 mm (3'7 ⁵ / ₁₆ "), with cutout, alu plain anodized, brushed	left	21838
		right	21839
	Glass suspension profile 1100 mm (3'7 ⁵ / ₁₆ "), with cutout, alu unanodized (straight profile)	left	23505
		right	23506
	Glass suspension profile, 1100 mm (3'7 ⁵ / ₁₆ "), with cutout, alu plain anodized, brushed (straight profile)	left	23507
		right	23508
	Glass suspension/retainer profile 1100 mm (3'7 ⁵ / ₁₆ "), with cutout, alu unanodized	left	13872
		right	13873
	Glass suspension/retainer profile 1100 mm (3'7 ⁵ / ₁₆ "), with cutout, alu plain anodized, brushed	left	21840
		right	21841
	Glass suspension/retainer profile 1100 mm (3'7 ⁵ / ₁₆ "), with cutout, alu unanodized (straight profile)	left	23480
		right	23481
	Glass suspension/retainer profile 1100 mm (3'7 ⁵ / ₁₆ "), with cutout, alu plain anodized, brushed (straight profile)	left	23478
		right	23479
	Lock complete, for sliding swing door	left	13823
		rechts	13824
	Pivot bearing, galvanized steel	13827	
	Cover cap, incl. fixing screw	black	19903
	Cover cap, incl. fixing screw (straight profile)	black	23470
	Suspension profile cover cap, plastic (top)	black	14211
	Suspension profile cover cap, plastic (bottom)	black	13585

Components for sliding swing door



		code	
	Glass suspension profile cover cap, plastic	black	13586
	Glass suspension profile cover cap, plastic (straight profile)	black	23437
	Coupling mechanism to floor door closer, galvanized steel		13825
	Floor door closer GEZE TS 520 with special axis for sliding swing door		13798
	Cover plate to floor door closer, chrome-nickel steel		13799
	Adapter for DORMA floor door closer		14178
	Connecting handle 8 mm (5 ¹ / ₁₆ ")		15659
	Short connecting rod for door height up to 2500 mm (8'2 ⁷ / ₁₆ ")		14164
	Long connecting rod for door height over 2500 mm (8'2 ⁷ / ₁₆ ")		14165
	Instruction		14074

Subject to modification. Metric specifications are exact. Inches are approximate.

Profile processing

		left	right
Cutout for safety lock, for double cylinder	17 mm ($\frac{11^m}{16}$)	17987	17988
	22 mm ($\frac{7^m}{8}$)	17989	17990
Cutout for safety lock, for double cylinder (straight profile)	17 mm ($\frac{11^m}{16}$)	23482	23483
	22 mm ($\frac{7^m}{8}$)	23484	23485
Cutout for safety lock, for single cylinder	17 mm ($\frac{11^m}{16}$)	17993	17994
	22 mm ($\frac{7^m}{8}$)	17995	17996
Cutout for safety lock, for single cylinder (straight profile)	17 mm ($\frac{11^m}{16}$)	23486	23487
	22 mm ($\frac{7^m}{8}$)	23488	23489
Cutout for safety lock, square/hexagon socket		17991	17992
Cutout for safety lock, square/hexagon socket (straight profile)		23490	23491
Cutout for deadbolt lock for sliding pivot door		14085	14086
Cutout for deadbolt lock for sliding pivot door (straight profile)		23492	23493
Cutout deadbolt lock with guide pin		14186	14187
Cutout deadbolt lock with guide pin (straight profile)		23494	23495
Cutout for deadbolt lock, for side fixing		17973	17974
Cutout for deadbolt lock, for side fixing (straight profile)		23496	23497
Cutout for coupling mechanism for sliding swing door		14040	14041
Cutout for coupling mechanism for sliding swing door (straight profile)		23498	23499
Cutout lock for glass suspension profile SDT/SPT		14042	14043
Cutout lock for glass suspension profile SDT/SPT (straight profile)		23509	23510
Cutout for bottom locking device, lateral operation		20724	20725
Cutout for TGP, external pivot, opening inwards		16709	16710
Cutout for TGP, external pivot, opening inwards (straight profile)		23500	23501
Cutout for dual top track, for external pivot, opening inwards		16713	16714
Suspension profile processing for top door closer		15411	15416
Retainer profile processing for top door closer		15412	15415
Retainer profile processing for limit stop to surface mounted top door closer, axis of rotation (straight profile)		23511	23512
Retainer profile processing for surface mounted top door closer (straight profile)		24475	24476
Lock cutout incl. drilling for single cylinder 17 mm ($\frac{11^m}{16}$)		23150	23149
Lock cutout incl. drilling for single cylinder 17 mm ($\frac{11^m}{16}$) (straight profile)		23700	23699
Lock cutout in glass suspension/retainer profile 230 mm ($9\frac{1^m}{16}$), for double cylinder	17 mm ($\frac{11^m}{16}$)	19901	19902
	22 mm ($\frac{7^m}{8}$)	19017	19018
Schlossausfräsung in Trag- und Glashalteprofil 230 mm, zu Zapfenschloss		19019	19020
Lock cutout incl. drilling for 17 mm ($\frac{11^m}{16}$) double cylinder			19615
Lock cutout incl. drilling for 17 mm ($\frac{11^m}{16}$) double cylinder (straight profile)			23502
Cutout for holding device for top tracks with integrated cover			15421

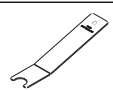
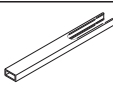
Tools

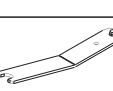
		code
	Fork spanner to glass holder insert	13817
	Installation tool for blocking keys 10/12/12.7 mm ($\frac{13^m}{32}$ / $\frac{15^m}{32}$ / $\frac{1^m}{2}$) glass	13710
	Fork spanner SW 17/8/13 for trolley 70 kg (154 lbs.)	15459
	Fork spanner SW 22/12/13 for trolley 100–150 kg (220–330 lbs.)	15409
	Wrench, hexagon 5 mm ($\frac{7^m}{16}$), SW 11 mm ($\frac{7^m}{16}$)	17110

Surface treatments

	code
Basic treatment fee to surface treatment, lump sum per colour	16741
Powdercoated to RAL tone No.	14163
Plain anodized, polished, brushed	14626
Stainless-steel effect, hard anodized, brushed, polished, mat finish	14378
Stainless-steel effect, nickel plated, brushed, mirror finish	14631
Chrome mirror finish	14630

Services

	code
Bending and assembly of dual top track with special radius HAWA-Variotec	17294
Bending of top tracks and bottom guide channels for HAWA-Variotec special curved segments	16041
Machine set-up time for each profile	16040
Curving and preparing all special radii, per track	16038
Preliminary mounting parking area	15653
Additional packing share for each Variotec/Combitec parking area	15654
Project processing/CAD planning, per hour	14035
Installation assistance per day, without expenses, net	17111
Installation assistance per hour, without expenses, net	17112

Stationary glass HAWA-Fixed Glass

You can combine fixed glass designs and sliding doors to form a harmonious unit using our supplementary HAWA-Fixed Glass hardware components. In this way you can ensure the best possible prerequisites for providing a uniform complete solution.

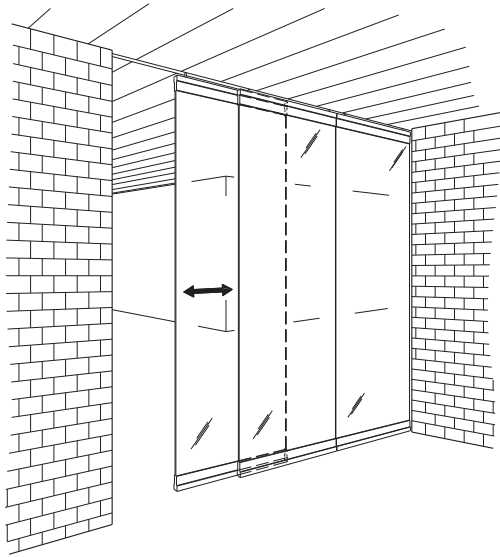

Stationary glass HAWA-Fixed Glass

		code
	Top fixing plate set for fixed glass, with hanger bolt M12, HAWA-Variotec 150/GV	14688
	Retainer device for fixed glass with dual top track	15803
	Bottom profile, alu plain anodized, undrilled	6000 mm (19'8 7/32")
		cut to size

Order specifications for HAWA-Fixed Glass

- Number and type of top-fixing plate sets
- Length of bottom profile

Planning/installation

For planning and installation purposes, please use the installation drawing code 15805. (→ www.hawa.ch → HAWA-Productfinder)

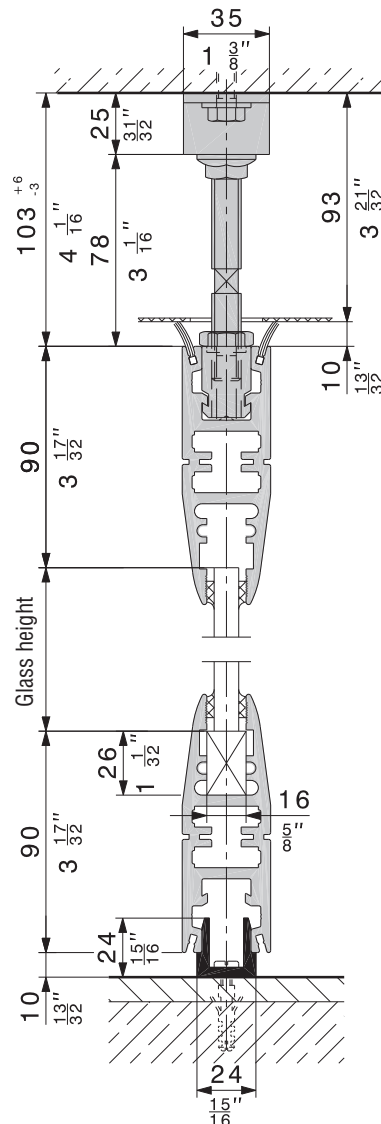
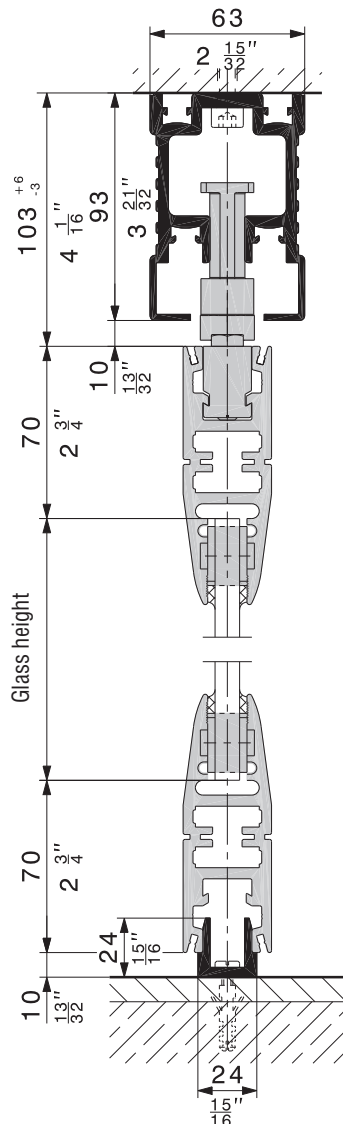

Subject to modification. Metric specifications are exact. Inches are approximate.



Subject to modification. Metric specifications are exact. Inches are approximate.