

LOFTZONE

STOREFLOOR

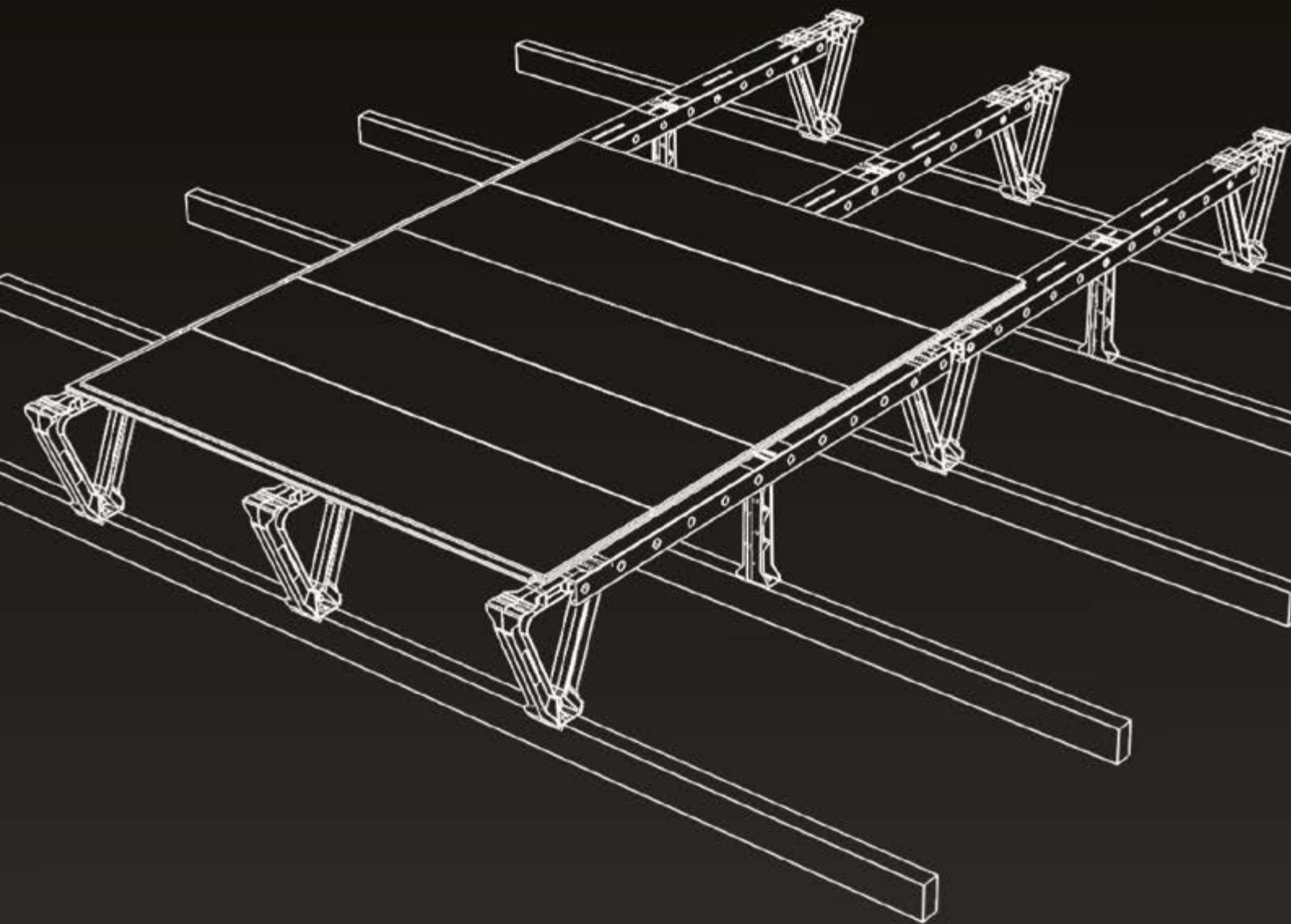

INSTALLATION INSTRUCTIONS

Attention

- Whilst working in a loft space with insulation we recommend wearing personal protective equipment. Insulation fibre can cause skin irritation and inhalation should also be avoided.
- Take care when using a ladder to access a loft space and place walk boards where access is required to install the deck.
- Ensure you do not step on the plasterboard ceiling as there is a risk of falling through.
- Loft spaces are confined and can have restricted headroom. Temperatures in lofts can be very high in summer and very cold in winter.
- Avoid contact with, or damaging, electric cables and pipework. If you choose the configuration correctly, you can span over such obstructions.
- StoreFloor should be used for the storage of light items due to the loading limit of the existing roof structure. Maximum weight loading on the StoreFloor is 25kg/m², unless you are sure your loft joists can bear greater loads. If in doubt about the strength of your joists, please consult a structural engineer about the loading limit of your existing roof structure.
- StoreFloor is not a replacement for a permanent fixed floor and is designed for occasional access only.
- Take care whilst working in a loft to ensure the plasterboard ceiling does not crack.

Before you begin

- Only install this product in a well-ventilated loft that is free from condensation.
- Ensure safe access to your loft and provide adequate lighting, taking care of trailing cables.
- Clear the area where StoreFloor will be located and load all materials into the loft, making sure they cannot slide back as you lift them up.
- Lay insulation between the joists, up to the top of the joist, if this has not already been done. Temporarily roll back any insulation above the joists; this will be replaced once StoreFloor is fitted.

NOTE: If you have downlighters in the floor of your loft, then provide adequate protection to these, by fitting a downlight insulation box over each light.

Parts Required

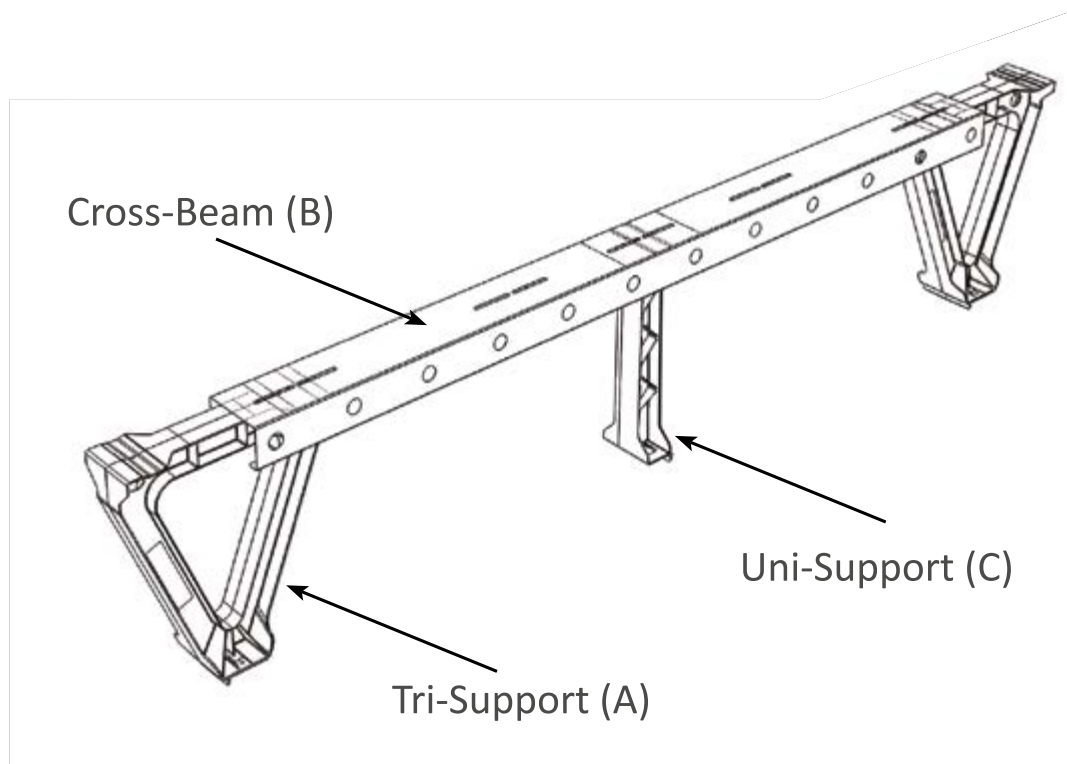

You will need 2 screws per Cross-Beam, 2 per Tri-Support and 2 per Uni-Support. We recommend 4 x 40mm (8 x 1½") wood screws. You can also use the same size screws to fix the loft boards on to the Cross-Beams.

Tools Required

Essential

- Gloves
- Appropriate Footwear
- Tape Measure
- Electric drill with screwdriver attachment

Recommended

- Mask
- Eye Protection
- Spare battery for electric cordless drill



Step 1

- Plan the configuration of your StoreFloor and where you would like it to be in your loft.
- Approximately set out where all the supports will be located ensuring they avoid obstructions in the loft, such as cables and pipes.

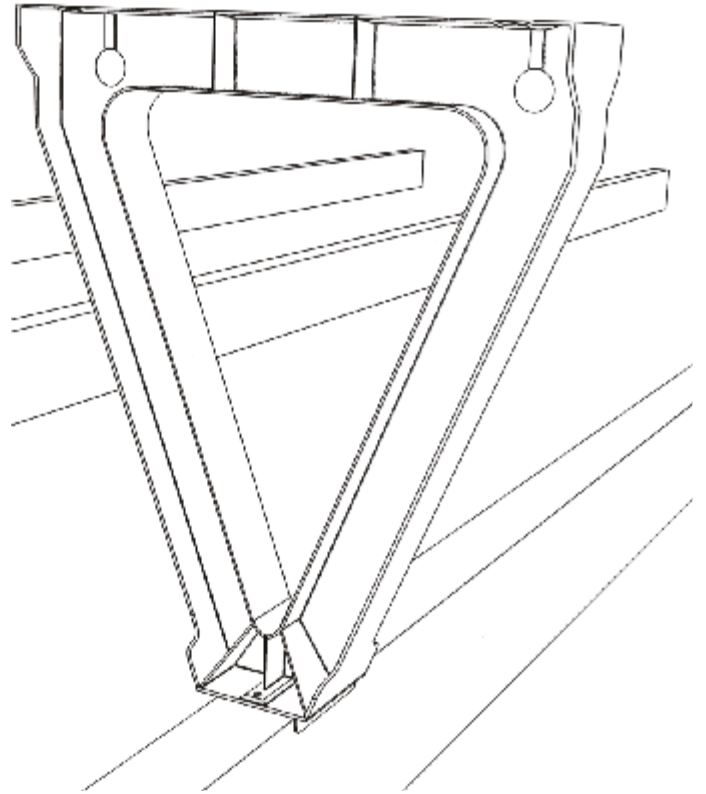

Step 2

- Screw in the first plastic Tri-Supports (A) to the joist.
- Ensure they are precisely 610mm apart, as measured centre-to-centre (if using a 1220mm standard loft board).
- Each Tri-Support should be fixed with two screws into the joist it sits on.
- If your joists are 600mm apart, then you will span over one joist between each row of Tri-Supports, as shown in the diagram. If your joists are 400mm apart, then you will span over two joists.

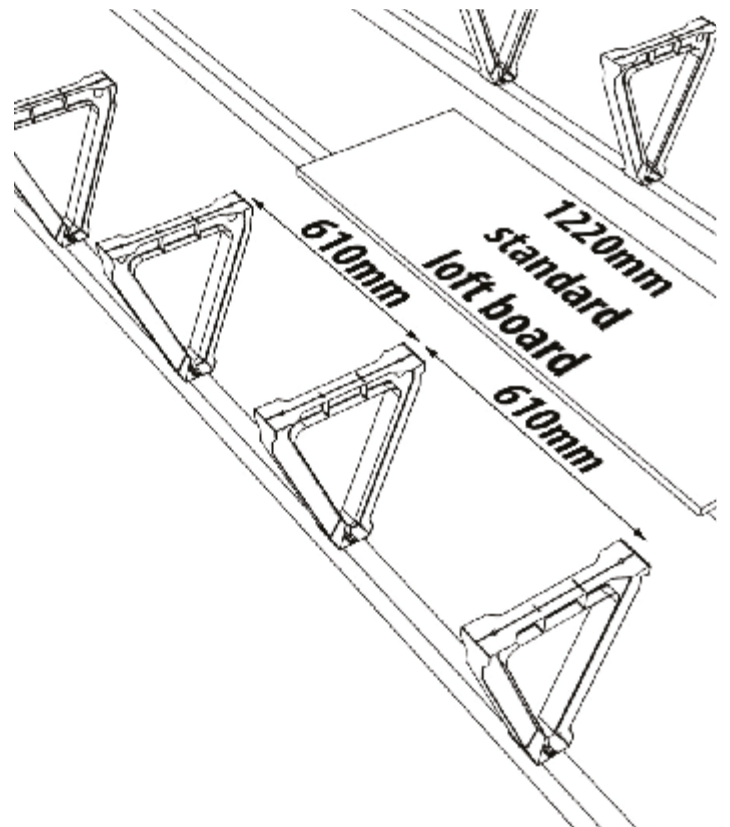

Step 3

- Slide the Cross-Beams (B) on to the Tri-Supports (A). It is not necessary for the Cross-Beams to slide right up to the middle of the Tri-Support.
- Once (A) & (B) are in position screw down firmly anywhere through the slit on the Cross-Beam into the pre-drilled hole in the top of the Tri-Support.

NOTE: It is normal for the Cross-Beams to be compressed down slightly into the support.

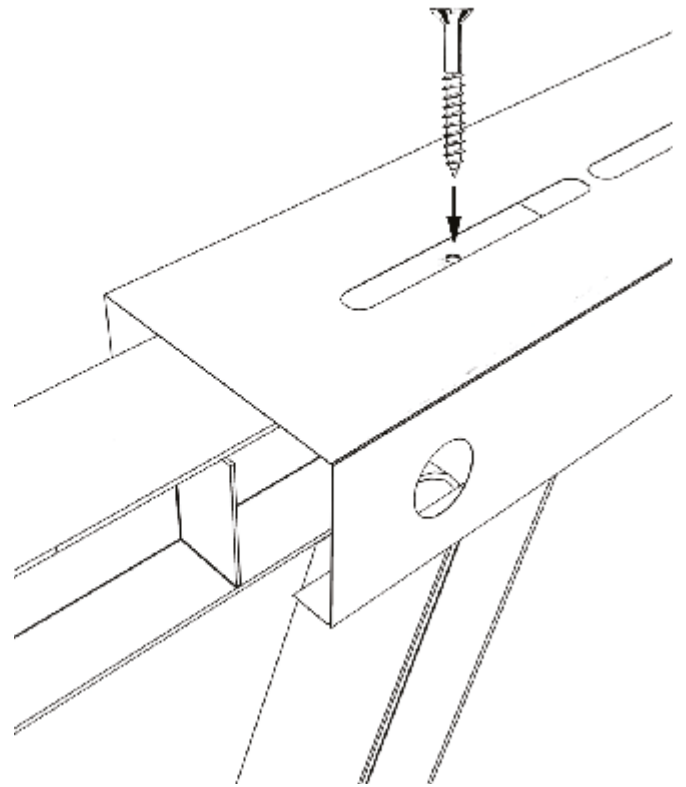

Step 4

- Install a Uni-Support (C) by placing it into the Cross-Beam and then rotating it into the locked position onto the joist.
- Screw down firmly through the slit on the Cross-Beam (B) into the pre-drilled hole in the top of the Uni-Support.
- Screw one screw securely to both the joist and the Cross-Beam. The screw can be inserted vertically or at an angle.
- Distribute the Uni-Supports evenly under the StoreFloor. We recommend one Uni-Support for every second Cross-Beam.

NOTE: Two holes are provided in the base of the Uni-Support but you only need one screw into the joist; we've provided two holes to make it easier to install from either side.

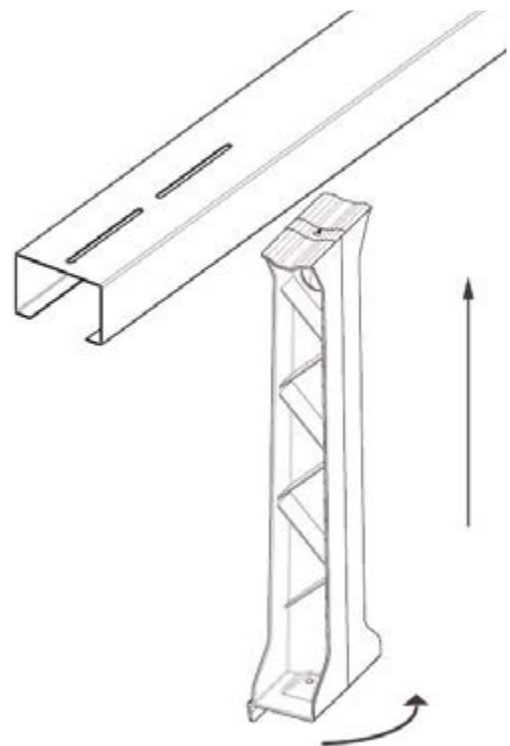

Step 5

- Now fit the full depth of insulation into position between the rows of Cross-Beams, making sure you don't leave gaps around the supports.
 - Screw the loft board flooring directly into the metal Cross-Beams, allowing for the tongue-and-groove fitting method of most loft boards. Do not try to fix the screws into the slits in the top of the Cross-Beams, but self-tap them into the metal directly. You may find it useful to use the hammer setting on your drill for this.
 - The boards should reach half-way across the 80mm width of the Cross-Beam; this is to allow a second board to butt up against it and for both boards to be supported by the same Cross-Beam. This is shown on the image on the front cover of this instructions booklet. At the ends of your deck, if you wish, you may prefer to let the board sit across the full width of the Cross-Beam. There is no need to stagger boards; the deck is strong enough without doing this.
-

Step 6 (optional)

- You can choose to make good the area around the loft hatch, with boards that are fixed vertically, as shown in this photo. However make sure you don't significantly block the airflow from eave-to-eave under the boards.



General tips and hints:

Ensure that there is an air gap between the bottom of the Cross-Beams and the top of the insulation; this is to allow air to flow from eave-to-eave across the top of the insulation and remove any moisture before it has a chance to condense on the underside of the boards.

- The area you choose for your StoreFloor doesn't need to be square or rectangular: some people prefer an 'L' or 'T' shape, or choose to have two StoreFloor areas, separated by a gap.
- It is not necessary to clear all your belongings from the loft before starting work. StoreFloor is built up in stages and so you can clear a small area, build the deck there, then place your belongings on to the new deck, before moving on to the next area.
- Height is reduced at the edges of your loft (the eaves), so you may not want to board all the way up to the very edge. You should also leave gaps for ventilation at the eaves.
- If you need to access anything fixed in the loft (e.g. a water tank, gas boiler or solar inverter), create a continuous path all the way from the loft hatch to the destination.
- StoreFloor is designed to protect up to 350mm of loft insulation, and can be fitted before, or after, the insulation. If there is no insulation, we advise fitting the first layer of insulation, up to joist height, followed by the StoreFloor supports and beams, followed by the rest of the insulation. If the full insulation is already present, then you will need to temporarily roll it to one side in the places where you want to fit the StoreFloor supports.
- If you change your mind, and want to add more raised flooring later on, it's easy to do. Extra parts are available to purchase individually.

Frequently asked questions

What size screws should I use?

We recommend 4x40mm wood screws. These can be screwed through the pilot holes provided in the supports, and also used to self tap through the boards into the metal of the Cross-Beams.

How many Uni-Supports do I need?

The Uni-Supports exist to provide extra stiffness to the deck and to spread the load on to more joists. We advise one Uni-Support fixed under every second Cross-Beam, spread out evenly underneath the deck. This is usually sufficient. However, if you want to load the deck heavily or access it very frequently, you may wish to fit extra Uni Supports, which are available to purchase individually.

What size joists will work?

The LoftZone system is designed to work with joists that are at least 32mm wide, and at least 50mm tall. Most loft joists are spaced at intervals of 400mm or 600mm and our Cross-Beams span these perfectly. However some houses have other, or uneven, joist spacing, and in these cases it may be necessary to cut the Cross-Beams to span the joists correctly, and to purchase additional supports. We recommend using tin snips or a saw to cut the Cross-Beams. They are very strong thanks to their design, but actually only 0.7mm thick.

What load can I put on the deck?

The LoftZone products have been independently tested to withstand loads of several hundred kilograms. However your loft joists are likely to be less strong than that, so we advise that you do not put more than 25kg per square metre continuously on any area of your deck, plus the weight of one person occasionally accessing the loft. Of course, many houses can exceed this, but we would recommend you consult a structural engineer before exceeding 25kg per square metre.

Some of my joists are uneven

A design feature of StoreFloor is that it spans over many joists. This makes it faster to install and also means that you can choose the layout to bridge over any uneven joists, where practical.

I'd like to create a non-standard sized-deck

It is possible to vary the size of a standard deck slightly, to achieve an exact fit, as follows:

- If you want to move the rows of beams closer together, you can simply do so by screwing the plastic Tri-Supports into the joists a little bit closer together.
- If you want to reduce the length of the Cross-Beams, it is possible to cut them, as described on the previous page. Remember to still support them at each end.

I am boarding the whole loft space and the last Cross-Beam of each run does not have enough space to slide on

Most people don't board right up to the edge, as they leave a gap for air flow around the edges. However if you do wish to do so then you can loosely slide the final sets of supports under the Cross-Beam, then position the Cross-Beam in place, before screwing everything together when all the items are in place.

What do I do if a row of Cross-Beams only just fits in my loft space and I don't have space to put a Tri-Support at the end?

In this case, we'd recommend putting a Uni-Support at the end of the row of beams. But make sure that you put the Tri-Support on the next-nearest joist.

I've decided I'd like to have someone else install this for me

Sure, that is no problem, contact us and we'll let you know the details of your nearest installer.

How do I include a loft ladder?

You have several options:

(1) You can use a concertina-style loft ladder which stows inside the hatch.



(2) You can fix a ladder on to a board at the top of the deck. In this case, we would strongly recommend that you support the hinge location with a Cross-Beam.



(3) You can fix a ladder on to a joist and stow it away from the deck.



(4) You can create a small platform at joist height to stow the ladder. But this means reducing or compressing insulation in that area.

