

# The superior **steel** rainwater system



Lindab Rainline™

Lightweight, cost-effective,  
easy to install and environmentally friendly



# About Lindab

With over half a century of experience in the development, manufacturing and marketing of sheet-metal products, Lindab has become one of the leading international players in the construction and HVAC industries.

In 1957, Lindab started out as a small sheet-metal shop in Lidhult, Sweden, and the year after Lindab moved to Båstad, on the Bjäre Peninsula in the south west of Sweden, where Lindab is situated today.

Lindab has since then expanded to a worldwide business with representation in 31 countries.

## It comes naturally

Lindab's business is based on long-term sustainable and environmentally friendly systems in steel and sheet metal. We focus on minimizing the use of raw materials, components, energy, packaging and transport. Today 90 per cent of our operations are certified according to ISO 14001. A full environmental declaration is available on request.

## Lindab's market presence

- 128 locations in 31 countries
- Local production units in 18 countries
- Over 1,000 Lindab distributors cover Europe and eastern/central USA
- Employs over 4,000 people
- Head Office on the beautiful Bjäre Peninsula in the south west of Sweden

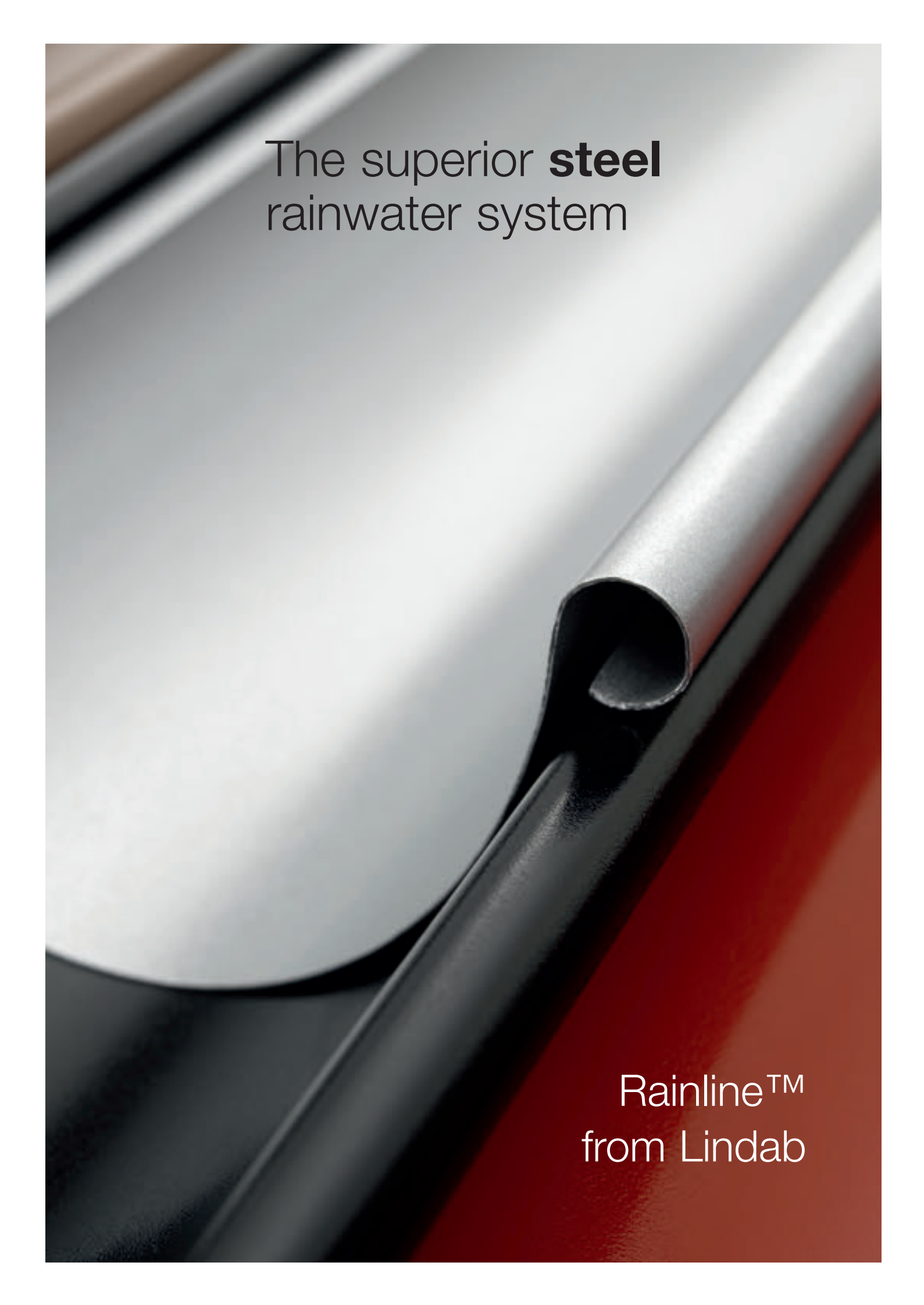

A close-up photograph of a steel rainwater pipe joint. The pipe is dark grey or black, and the joint is shown in a cross-section, revealing the internal structure. The background is a gradient of light grey to white, with a prominent red diagonal stripe running from the bottom right towards the center. The lighting is dramatic, highlighting the metallic texture and the sharp edges of the pipe.

The superior **steel**  
rainwater system

Rainline™  
from Lindab

# The steel rainwater system with the lowest CO<sub>2</sub> footprint

Lindab Rainline is the rain drainage system that offers the highest quality, with the lowest CO<sub>2</sub> footprint of any other system.

Rainline has been developed by professionals to combine durability, flexibility and ease of installation – and with steel's low cradle-to-grave CO<sub>2</sub> impact, it promises decades of performance.

A policy of continual research and development has made Rainline steel systems the top choice of tradesmen and DIY enthusiasts alike, with customer feedback ensuring that the Rainline system reflects the needs of the specifier, installer and end-user.

- 1 High-build polyester paint
- 2 Primer coating
- 3 Passivation layer
- 4 Zinc coating
- 5 Steel sheet

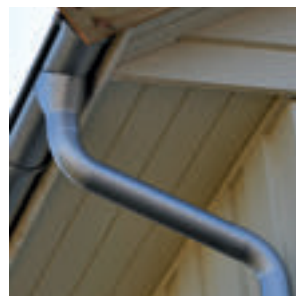
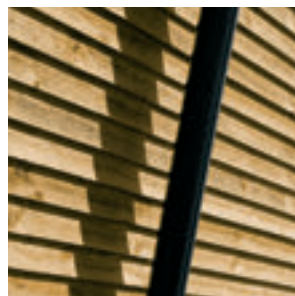
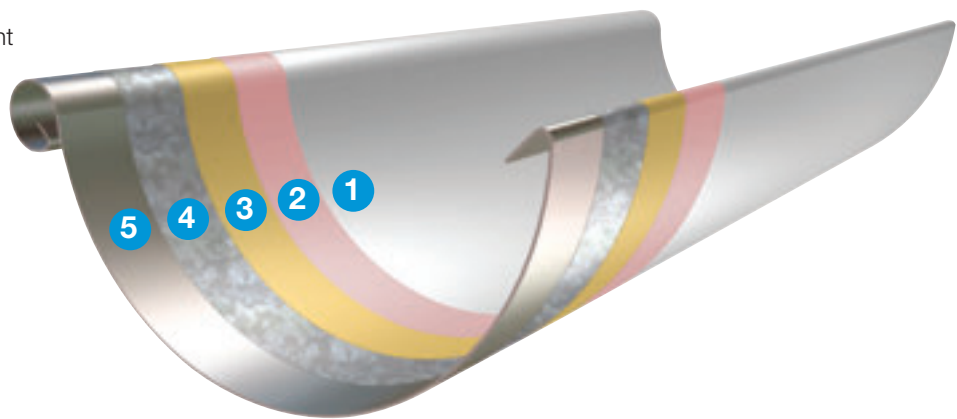

## Features and benefits of Lindab Rainline

### Made to last with the lowest cradle-to-grave impact

Steel is the ultimate material for roof-drainage systems. It is much lighter than cast iron, is easier to handle than aluminium and offers minimal thermal movement compared to plastic (which can move and crack causing leaks). Lindab's steel also has the lowest CO<sub>2</sub> impact of any competitor.

### Simplified construction

No specialist tools or skills are required; gutters and downpipes simply push together without the need for any sealants.

### Low maintenance

The only maintenance required is an occasional wipe or wash down. Easy assembly and installation guarantee a long service life.

### Vandal resistant

Highly resistant to attack from vandals – can be fixed flush to a wall to prevent anyone climbing up the downpipe.

### Material and colour choice

Steel is available in a choice of 10 standard colours (high-build polyester paint finishes) as well as plain galvanized and Aluzinc-coated finishes. Coated finishes are UV stable – will not fade or crack. The whole system is also available in pure natural copper.

### 15-year guarantee

Lindab Rainline High-Build Polyester coated products all come with a 15 year guarantee. As long as installation and warranty conditions have been followed any defects to the coating will be replaced.

*Plain galvanised material is not advised for projects in coastal regions where salt water can have a corrosive reaction. In these instances coated systems should be used.*

### Stylish design for a variety of buildings

Designed for large or small, classic or contemporary.

### Cost-effective solution

Competitively priced against leading plastic systems and inexpensive compared with aluminium and cast iron.

### Minimum environmental impact

Tests have proven that Rainline steel systems reflect the lowest cradle-to-grave impact by minimizing the use of raw materials, components, energy, packaging and transport.



# Choosing the right rainwater system has never been easier

Thanks to its many smart design solutions, Lindab Rainline has become the preferred roof drainage system by many professionals. With its unique hand-in-glove fit and overall quality it guarantees quick installation and a high functionality – for decades to come.

## 1. Smart bracket

This bracket can be adjusted to match any fascia board angle. Strong and extremely easy to fit.

## 2. Stop ends

These ends are self-sealing with an EPDM seal. They are non-handed, easily fitted with a single firm tap from a soft hammer.

## 3. Pipe holder

This holder is made from one piece of sheet steel, and mounts a pipe with one firm click and fixes with two screws.

## 4. Gutter joint

These joints are easy to fit, creating a very firm and durable joint. The joints are guaranteed leak-proof with a long-lasting EPDM seal.

## 5. Outlet

This versatile gutter outlet easily fits to the semi-circular shape of the gutter. A minimum of a 2-inch diameter hole needs to be drilled or cut out of the gutter before the outlet is assembled.



## We've got a colour that will suit you

Extra durable high-build polyester paint finishes



**Antique White**  
RAL 9002



**Black**  
RAL 9005



**Silver Metallic**  
RAL 9006



**Brown**  
RAL 8017



**Dark Grey**  
RAL 7011



**Copper Metallic**  
RAL 8003



**Tile Red**  
RAL 8004



**Dark Red**  
RAL 3009



**Anthracite Metallic**  
RAL 9007



**Pine Green**  
RAL 6020



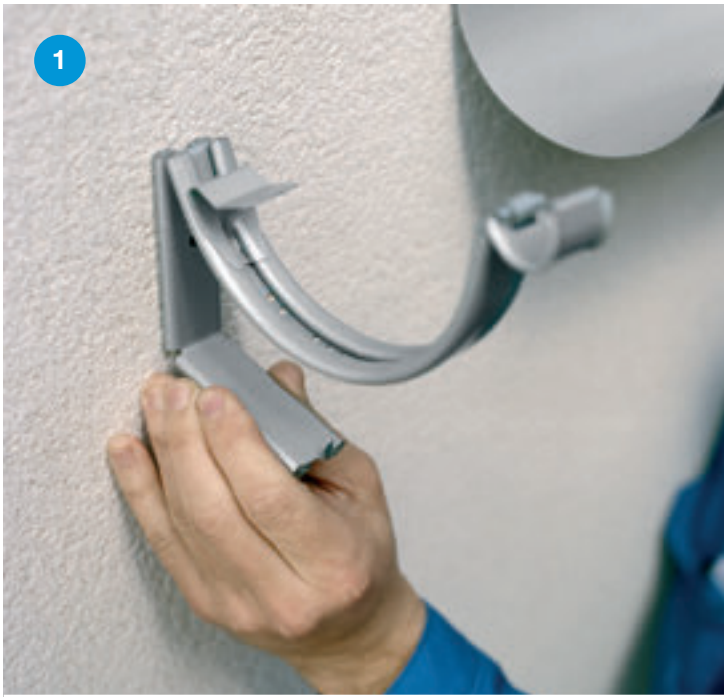

# We're here to help with advice and assistance

At Lindab Building Products, our aim is to match the reliability of our products with that of our service. Customer support is a core part of our business philosophy.

We are proud of the relationships we have developed with local authorities, housing associations, exclusive developers, contractors and end-users across the UK. We have only done this by adopting the right approach to both customers and end-users, and a focus on delivering products with a low CO<sub>2</sub> impact.

### Office support

We have dedicated customer support at our UK Head Office in the Midlands which can provide you with technical assistance, quotes, order entry and problem-solving solutions just by picking up the phone. Send us your building drawings and we will even do a "product take-off" for you free of charge.

### Field Support

We have a dedicated team of Area Managers who have been trained to the highest degree on our Rainwater System. Our team is available to visit you either on site or in your office/premises. We will give you full technical support on site and work closely with your designated contractor. Our team can also offer product demonstrations / seminars / CPDs at your place of work to enable you to make the right choice.

### Distribution

We can normally deliver standard items to you within 3-5 working days. Deliveries are made directly from our distribution centre in the Midlands. We also have a database of approved distributors across the UK which can help you with orders, quotes and arranging visits from our Area Managers.

For more information about our product range or to find your nearest stockist, please do not hesitate to contact us.

## Benefits of Rainline

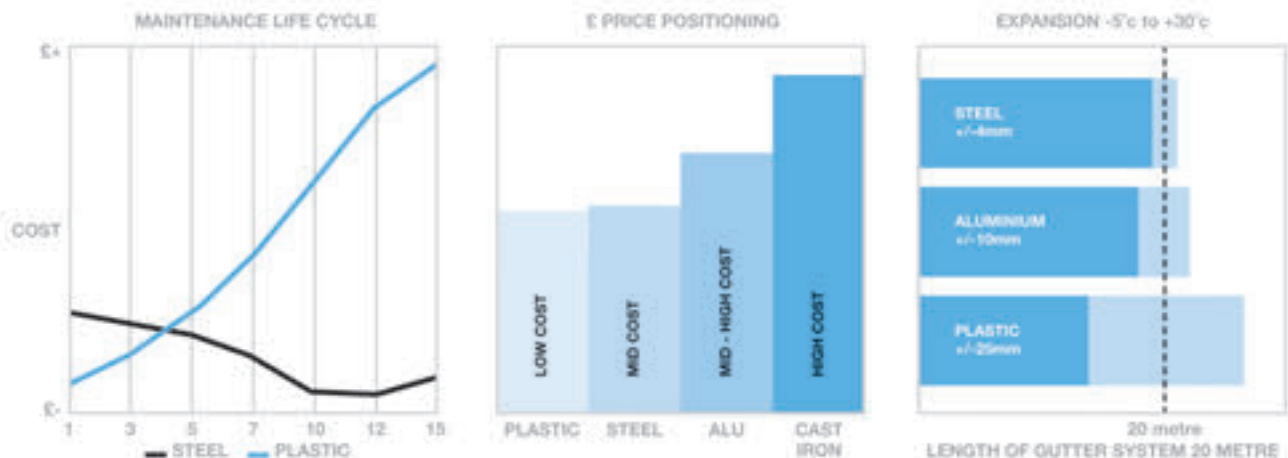

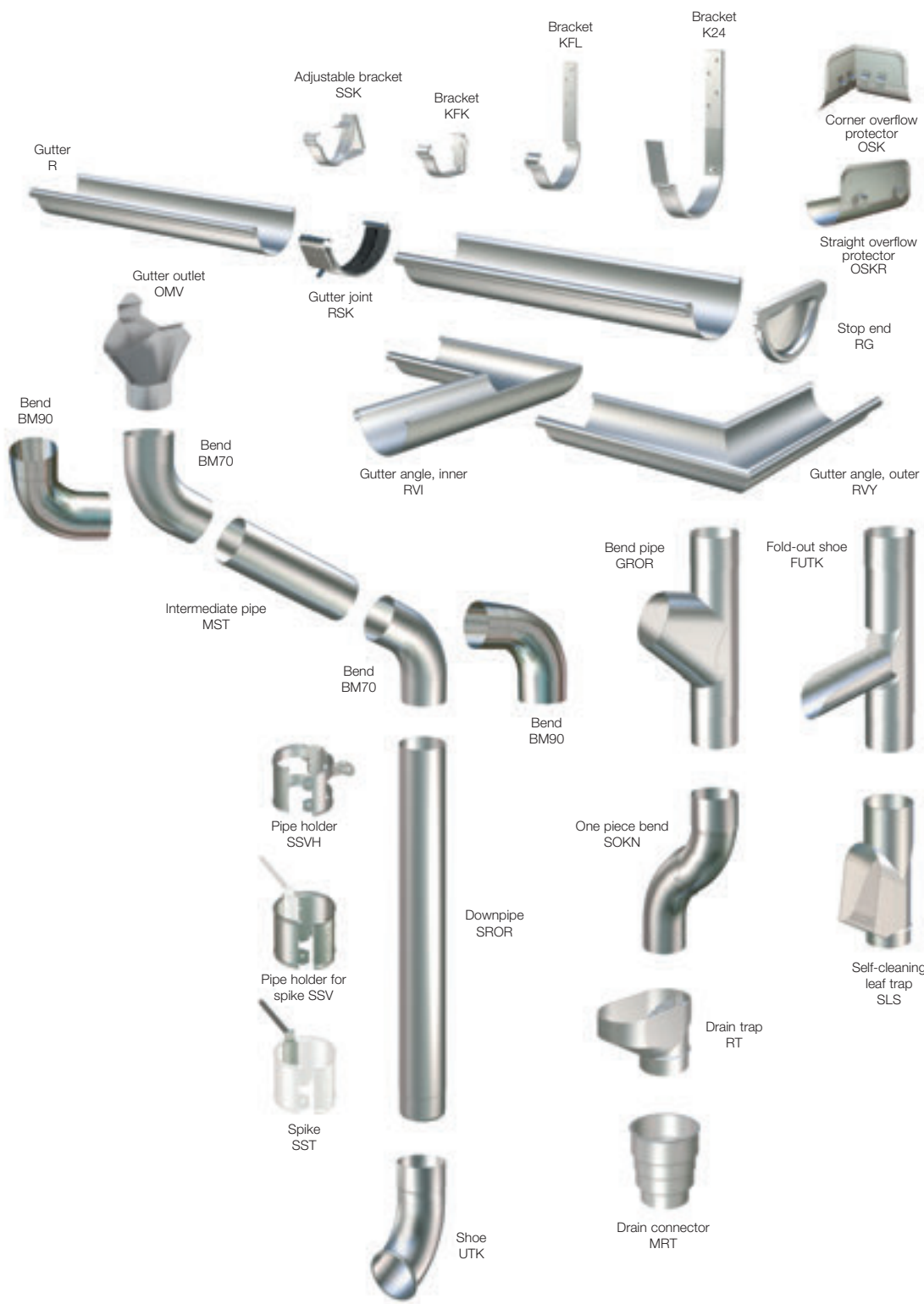

## Technical Facts **Half Round Gutter & Accessories**

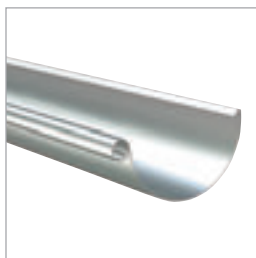

### R Half Round Gutter. Standard Length 3m

Size mm	D mm	d mm	Galv	Coated	Aluzinc
R100-3m	107	17	✓	✓	N/A
R125-3m	123	17	✓	✓	✓
R150-3m	155	17	✓	✓	✓
R190-3m	192	22	✓	✓	N/A

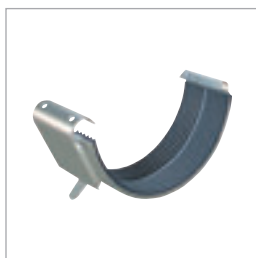
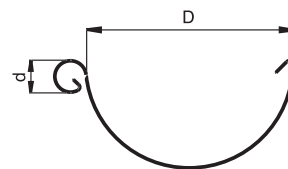

### RSK Gutter Joint with EPDM Rubber Seal

Size mm	Galv	Coated	Aluzinc
RSK-100	✓	✓	N/A
RSK-125	✓	✓	✓
RSK-150	✓	✓	✓

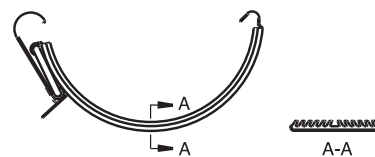

### KFK Fascia Bracket

Size mm	Galv	Coated	Aluzinc
KFK-100	✓	✓	N/A
KFK-125	✓	✓	N/A*
KFK-150	✓	✓	N/A*

\*Order in silver metallic.

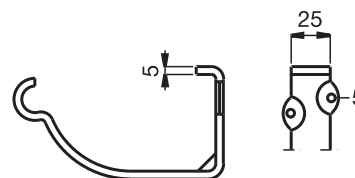

### K24 Fascia Bracket

Size mm	L mm	Galv	Coated	Aluzinc
K24-190	107	✓	✓	N/A

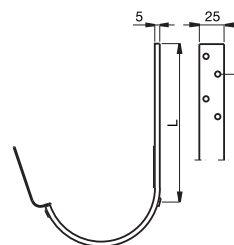

### SSK Adjustable Snap-On Bracket

Size mm	Galv	Coated	Aluzinc
SSK-100	N/A*	✓	N/A
SSK-125	N/A*	✓	N/A*
SSK-150	N/A*	✓	N/A*

\*Order in silver metallic.

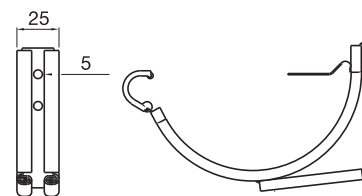

### KFL Rafter Bracket\*

Size mm	L mm	Galv	Coated	Aluzinc
KFL-100	196	✓	✓	N/A
KFL-125	196	✓	✓	N/A*
KFL-150	196	✓	✓	N/A*

\*Order in silver metallic.

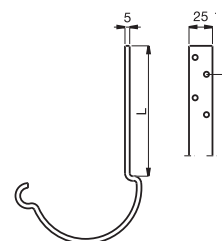

## Technical Facts **Half Round Gutter & Accessories**



### K33 Rafter Bracket

Size mm	L mm	Galv	Coated	Aluzinc
K33-190	337	✓	✓	N/A

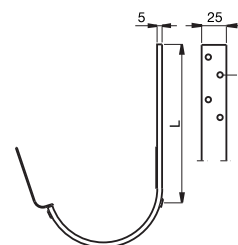

### RFKF Rise and Fall Bracket

Size mm	Thread mm	Spike mm	Galv	Coated	Aluzinc
RFKF-100	250	300	✓	✓	N/A
RFKF-125	250	300	✓	✓	N/A*
RFKF-150	250	300	✓	✓	N/A*

\*Order in silver metallic.



### RG Stop End, Self-Locking (Non-Handed) with EPDM Rubber Seal

Size mm	Galv	Coated	Aluzinc
RG-100	✓	✓	N/A
RG-125	✓	✓	✓
RG-150	✓	✓	✓

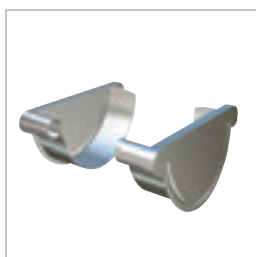
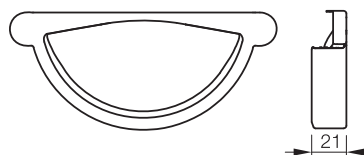

### RGV/RGH Stop End (Left/Right Handed)

Size mm	Galv	Coated	Aluzinc
RGV/H-190	✓	✓	N/A



### RVI 90° Gutter Angle: Inner

Size mm	L mm	Galv	Coated	Aluzinc
RVI-100	400	✓	✓	N/A
RVI-125	300	✓	✓	✓
RVI-150	300	✓	✓	✓
RVI-190	500	✓	✓	N/A

\*135° angle 50% extra / special angles 100% extra. 2 jointers required per angle.

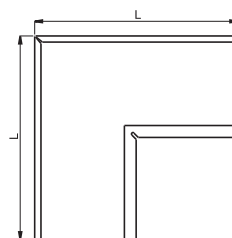

### RVY 90° Gutter Angle: Outer

Size mm	L mm	Galv	Coated	Aluzinc
RVY-100	295	✓	✓	N/A
RVY-125	160	✓	✓	✓
RVY-150	130	✓	✓	✓
RVY-190	285	✓	✓	N/A

\*135° angle 50% extra / special angles 100% extra. 2 jointers required per angle.

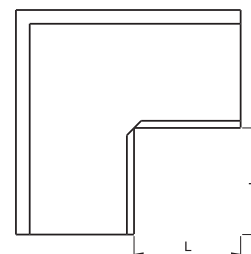

## Technical Facts Half Round Gutter & Accessories

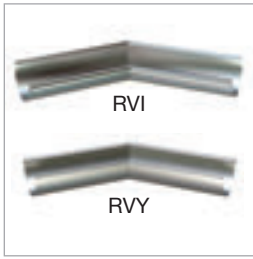

### RVI/RVY 135° Gutter Angle: internal

Size mm	Galv	Coated	Aluzinc
RVI/RVY-100	✓	✓	N/A
RVI/RVY-125	✓	✓	✓
RVI/RVY-150	✓	✓	✓

Special angles 100% extra. 2 jointers required per angle

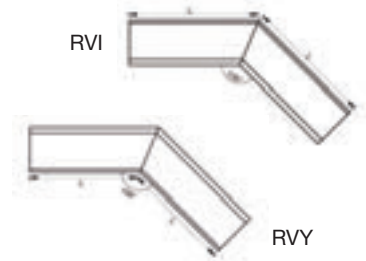

### OSK Corner Overflow Protector

Size mm	Galv	Coated	Aluzinc
OSK	✓	✓	✓

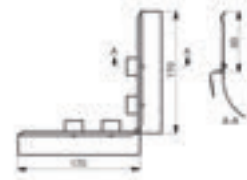

### OSKR Straight Overflow Protector

Size mm	Galv	Coated	Aluzinc
OSKR-125	✓	✓	✓
OSKR-150	✓	✓	✓

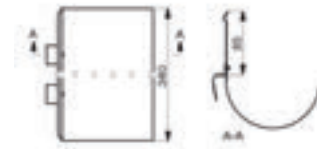

### OMV Gutter Outlet

Size mm	A mm	Galv	Coated	Aluzinc
OMV-100	151	✓	✓	N/A
OMV-125	174	✓	✓	✓
OMV-150	207	✓	✓	✓
OMV-190	180	✓	✓	N/A

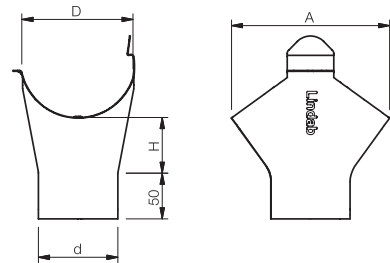

## Technical Facts Down Pipe & Accessories



### SROR Down Pipe: Standard Length 3m

Size mm	Galv	Coated	Aluzinc
SROR-75	✓	✓	✓
SROR-87	✓	✓	✓
SROR-100	✓	✓	✓
SROR-120	✓	✓	N/A

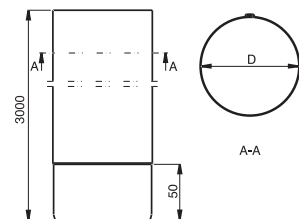

### SSVH Down Pipe Bracket

Size mm	Galv	Coated	Aluzinc
SSVH-75	✓	✓	✓
SSVH-87	✓	✓	✓
SSVH-100	✓	✓	✓
SSVH-120	✓	✓	N/A

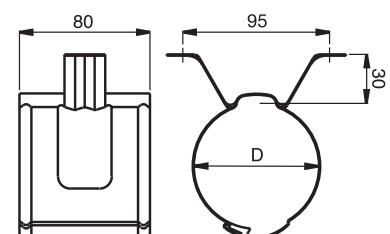

Technical Facts **Down Pipe & Accessories**



**SSV Pipe Holder for Spike**

Size mm	Galv	Coated	Aluzinc
SSV-75	✓	✓	✓
SSV-87	✓	✓	✓
SSV-100	✓	✓	✓
SSV-120	✓	✓	N/A



**SST Spike (Only available in Galv)**

Size mm	Galv	Coated	Aluzinc
SST-125	✓	N/A	N/A
SST-175	✓	N/A	N/A
SST-250	✓	N/A	N/A
SST-300	✓	N/A	N/A



**MST Intermediate Pipe x 1m**

Size mm	Galv	Coated	Aluzinc
MST-75	✓	✓	✓
MST-87	✓	✓	✓
MST-100	✓	✓	✓
MST-120	✓	✓	N/A

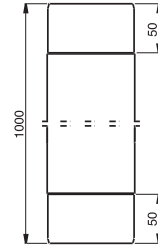

**MSTR Rod Access Pipe x 1m**

Size mm	Galv	Coated	Aluzinc
MSTR-75	✓	✓	✓
MSTR-87	✓	✓	✓
MSTR-100	✓	✓	✓
MSTR-120	✓	✓	N/A

Inspection door available in plain Galv as standard. Can be colour matched at extra cost.

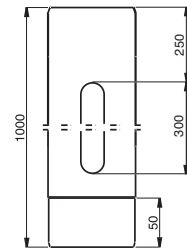

**BM 70° Pipe Bend (2 bends per offset required)**

Size mm	R mm	Galv	Coated	Aluzinc
BM70-75	90	✓	✓	✓
BM70-87	100	✓	✓	✓
BM70-100	125	✓	✓	✓
BM70-120	125	✓	✓	✓

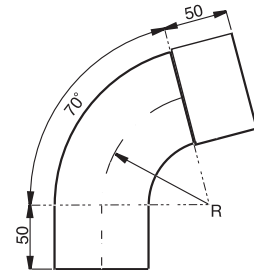

**BM 90° Pipe Bend (2 bends per offset required)**

Size mm	R mm	Galv	Coated	Aluzinc
BM90-75	90	✓	✓	✓
BM90-87	N/A	✓	✓	✓
BM90-100	N/A	✓	✓	✓

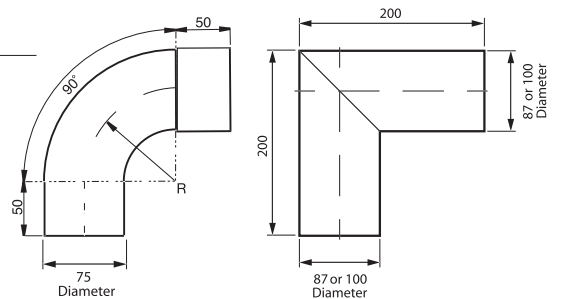

Technical Facts **Down Pipe & Accessories**



**UTK Pipe Shoe**

Size mm	R mm	L mm	Galv	Coated	Aluzinc
UTK-75	105	165	✓	✓	✓
UTK-87	105	170	✓	✓	✓
UTK-100	105	175	✓	✓	✓
UTK-120	125	205	✓	✓	N/A

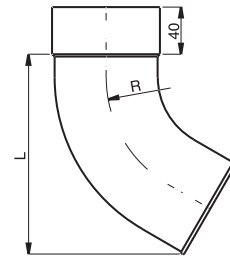

**SRORM Pipe Connector**

Size mm	Galv	Coated	Aluzinc
SRORM-75	✓	✓	N/A*
SRORM-87	✓	✓	N/A*
SRORM-100	✓	✓	N/A*

\*Order in silver metallic.

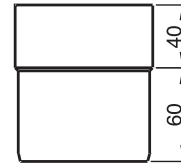

**GROR Branch**

Size mm	Galv	Coated	Aluzinc
GROR-75	✓	✓	✓
GROR-87	✓	✓	✓
GROR-100	✓	✓	✓

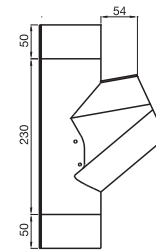

**FUTK Adjustable Shoe (manual)**

Size mm	Galv	Coated	Aluzinc
FUTK-75	✓	✓	✓
FUTK-87	✓	✓	✓
FUTK-100	✓	✓	✓

Conventional rainwater filter and diverter available in plastic, see top of page 11.

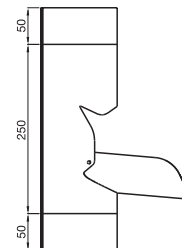

**SOKN One Piece Bend**

Size mm	Galv	Coated	Aluzinc
SOKN-75	✓	✓	✓
SOKN-87	✓	✓	✓
SOKN-100	✓	✓	✓

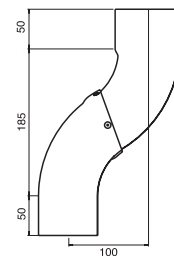

Technical Facts **Down Pipe & Accessories**



**VATKR-R Small Rectangular Water Hopper**

Size mm	Galv	Coated	Aluzinc
VATKR-75	✓	✓	N/A
VATKR-87	✓	✓	N/A
VATKR-100	✓	✓	N/A
VATKR-120	✓	✓	N/A

Only available in selected colours.

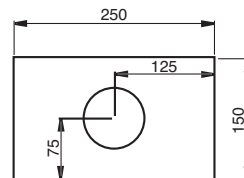

**VATKL-L Large Square Water Hopper**

Size mm	Galv	Coated	Aluzinc
VATKL-75	✓	✓	✓
VATKL-87	✓	✓	✓
VATKL-100	✓	✓	✓
VATKL-120	✓	✓	N/A

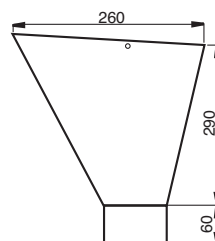

**RT Drain Trap for Down Pipes (HD polythene)**

Leaf strainer. The lower diameter fits standard ground drainage pipes.

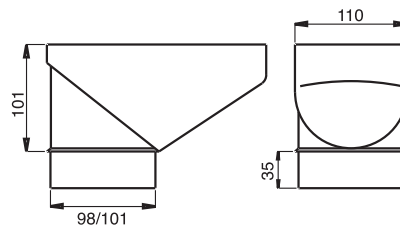

**SLS Self-Cleaning Leaf Trap (HD polythene)**

Self-cleaning leaf strainer. The lower diameter fits standard ground pipes.

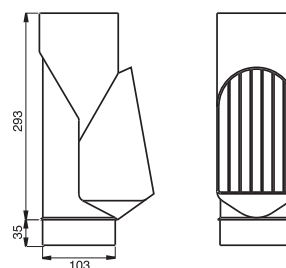

**MRT Drainage Connector (HD polythene)**

Drainage adapter. For connection to ground pipes with other dimensions than standard.

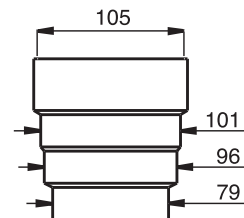

**Accessories continue on back page**



Technical Facts **Accessories**



**Rain Water Diverter**

Size mm	Material	Colours
Suits pipe dia 75mm & 87mm	Plastic	Black & White



**Leafline Gutter Brush – Length 3M**

**Description**

Leafline Gutter Brushes help maintain water flow by keeping it clear of leaves, twigs, birds and rodents.

**Size (diameters)**

100mm  
125mm  
150mm

**Colour**

Black

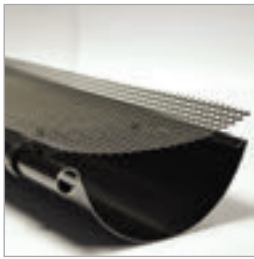

**Gutter Leaf Guard – Length 10M (HD polythene)**

**Description**

Gutter Leaf Guard (23 clips included) Additional black or white clips can be ordered



**KBO Bracket Bender**

**Description**

Bracket Bender for KFL Rafter bracket



**Fixing Screws (50 per bag)**

**Colour**

Galv finish only

**Size**

4.8mm x 25mm



**Touch-Up Paint**

**Description**

STIFT Touch-up paint .0121 litre  
BF-250 Touch-up paint .250 litre

**Lindab Ltd  
Building Products Division**

Shenstone Trading Estate  
Bromsgrove Road  
Halesowen  
West Midlands  
B63 3XB

Tel: (0121) 585 2780  
Fax: (0121) 585 2782  
Email: buildingproducts.sales@lindab.co.uk  
Web: www.lindab.co.uk



www.lindab.co.uk