

ZUCCHINI MR - MEDIUM RATING BUSBAR

Available in sizes from 160 to 1000 A, MR (medium rating) busbar is ideal for power distribution in medium to large installations and rising mains in commercial buildings.

MR is available with aluminium or copper conductors and has a large range of tap-off boxes from 16 to 1000 A, allowing the supply and protection of a wide range of loads using devices such as fuses, MCBs and MCCBs.

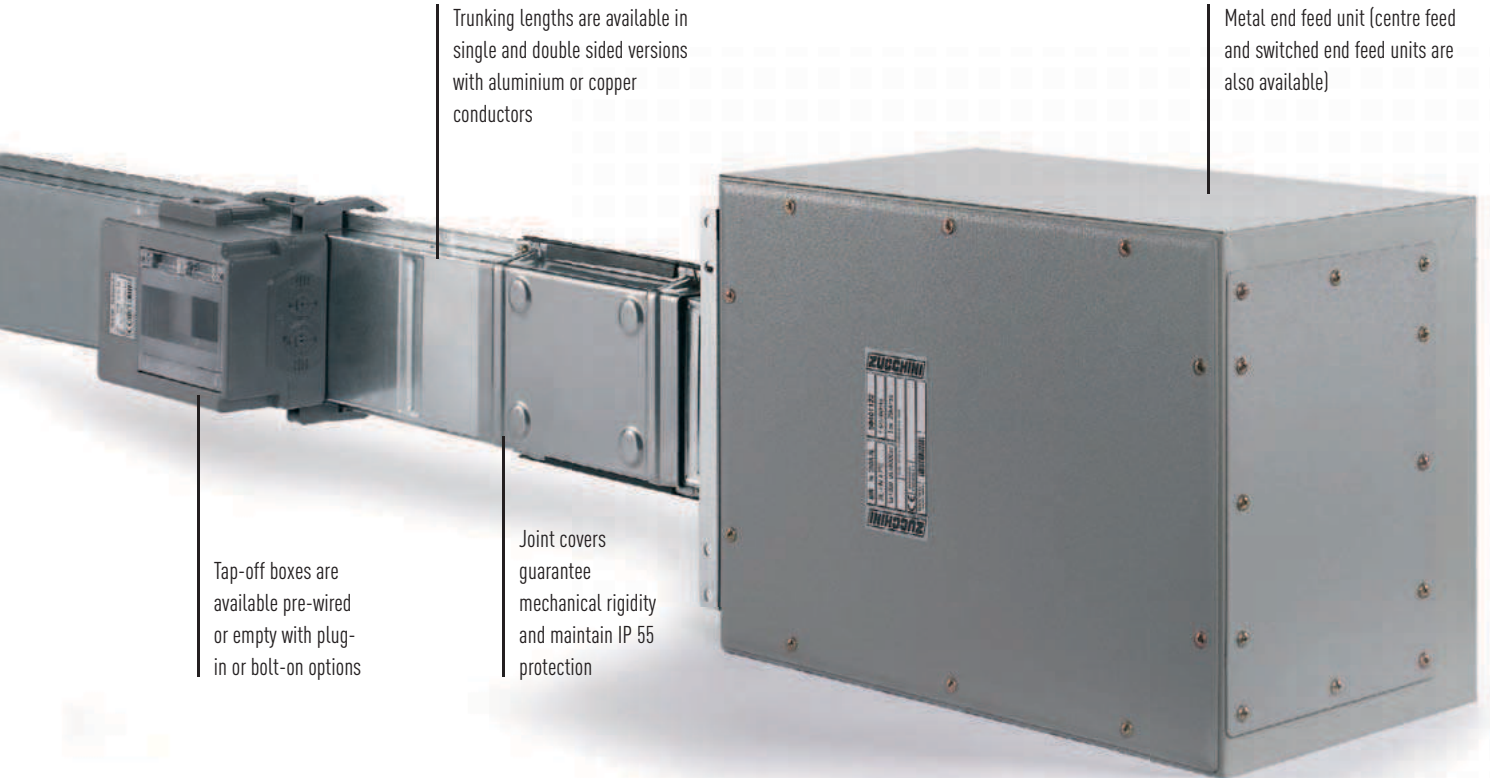



Trunking lengths are available in single and double sided versions with aluminium or copper conductors

Metal end feed unit (centre feed and switched end feed units are also available)

Tap-off boxes are available pre-wired or empty with plug-in or bolt-on options

Joint covers guarantee mechanical rigidity and maintain IP 55 protection



SWITCHBOARD - TRANSFORMER FEED UNIT

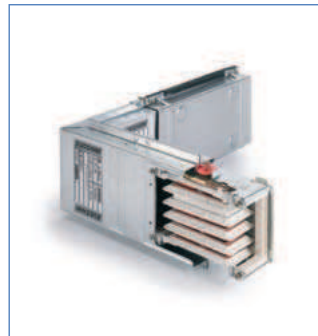

HORIZONTAL ELBOW



VERTICAL ELBOW



TAP-OFF BOXES



Lowering lifetime installation costs

MR features a monobloc electrical jointing system. The shearhead bolt on the monobloc allows for fast assembly of the run and guarantees long-term reliability and safety.

As well as being quick to install, Zucchini MR busbar is easy to upgrade if existing installations need to be modified. The vast choice of elbows, tees and other accessories make any configuration possible, with bespoke solutions also available on request.

MR medium rating busbar

medium power 160 - 1000 A

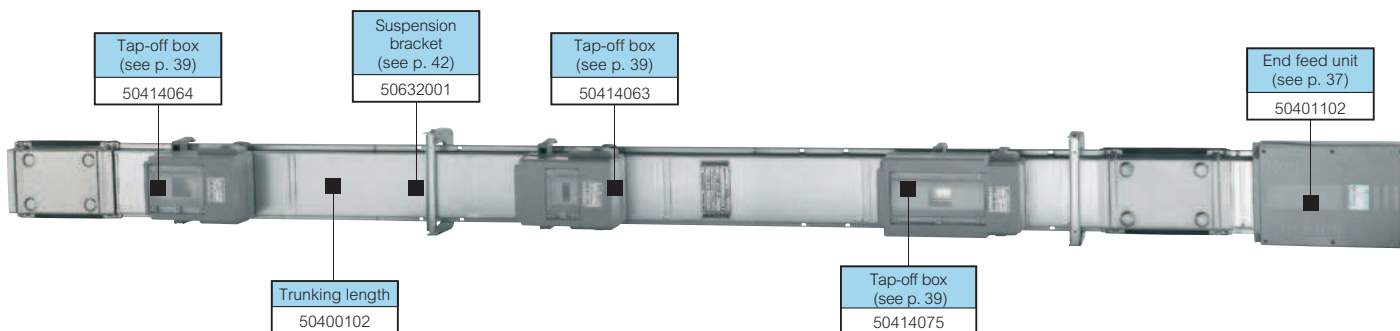

Dimensions and technical information **p. 43**

Measuring bespoke dimensions **p. 49**

Technical data **p. 52-56**

IP 55 (according to BS EN 60529)

Flame retardant in compliance with IEC 60332-3. Fully compliant with BS EN 60439-2

Rated currents are at an average ambient temperature of 40° C (over and above the required standard of 35° C)

Pack	Cat. Nos.		Trunking lengths – 3 m		
			For vertical runs or riser applications. Special lengths between 400 mm and 3 m are available upon request		
			With 3 + 3 outlets		
			Tap-off outlets are spaced every 1.0 m on both sides (6 positions per 3 m length)		
				Weight (kg)	
	Aluminium	Copper	Rating (A)	Aluminium	Copper
1	50400101		160	19.9	–
1	50400102	55400102	250	20.9	25.7
1	50400103	55400103	315	22.8	28.1
1	50400104	55400104	400	33.8	36.9
1	50400108		500	37.5	–
1	50400105	55400105	630	41.7	56.0
1	50400106	55400106	800	44.3	72.1
1	50400107 ¹	55400107	1000	46.8	83.7
			With 5 outlets on one side		
			Suitable for rising mains (see p. 50)		
				Weight (kg)	
			Rating (A)	Aluminium	Copper
1	50400251		160	19.9	–
1	50400252	55400252	250	20.9	25.7
1	50400253	55400253	315	22.8	28.1
1	50400254	55400254	400	33.8	36.9
1	50400258		500	37.5	–
1	50400255	55400255	630	41.7	56.0
1	50400256	55400256	800	44.3	72.1
1	50400257 ¹	55400257	1000	46.8	83.7
			Without outlets		
			Feeder lengths. A tap-off point is only possible on the junction between two lengths (see bolt-on tap-off boxes p. 41)		
				Weight (kg)	
			Rating (A)	Aluminium	Copper
1	50400241		160	19.9	–
1	50400242	55400242	250	20.9	25.7
1	50400243	55400243	315	22.8	28.1
1	50400244	55400244	400	33.8	36.9
1	50400248		500	37.5	–
1	50400245	55400245	630	41.7	56.1
1	50400246	55400246	800	44.3	72.1
1	50400247 ¹	55400247	1000	46.8	83.7

Pack	Cat. Nos.		Trunking lengths – bespoke dimensions	
			Please specify required length when ordering (see p. 49 – how to measure bespoke dimensions)	
			1501 to 2999 mm lengths with 2 + 2 outlets	
			Tap-off outlets in fixed position on both sides	
				Rating (A)
1	Aluminium	Copper	50400151	160
1	50400152	55400152	50400153	250
1	50400153	55400153	50400154	315
1	50400154	55400154	50400158	400
1	50400158		50400155	500
1	50400155	55400155	50400156	630
1	50400156	55400156	50400157 ¹	800
1	50400157 ¹	55400157		1000
			1501 to 2999 mm lengths without outlets	
			Feeder lengths. A tap-off point is only possible on the junction between two lengths (see bolt-on tap-off boxes p. 41)	
				Rating (A)
1	50400121		50400122	160
1	50400122	55400122	50400123	250
1	50400123	55400123	50400124	315
1	50400124	55400124	50400128	400
1	50400128		50400125	500
1	50400125	55400125	50400126	630
1	50400126	55400126	50400127 ¹	800
1	50400127 ¹	55400127		1000

Key : How to select the correct configuration and finish
 All examples on this page show 4 conductor galvanised lengths
 No. of conductors and finish is dictated by the red number
 0 = 4 conductors. Galvanised 2 = 4 conductors. Painted
 1 = 5 conductors. Galvanised 3 = 5 conductors. Painted
 Replace 0 with 1, 2, or 3 if required

1 : The 1000 A aluminium is supplied painted as standard

MR medium rating busbar

medium power 160 - 1000 A

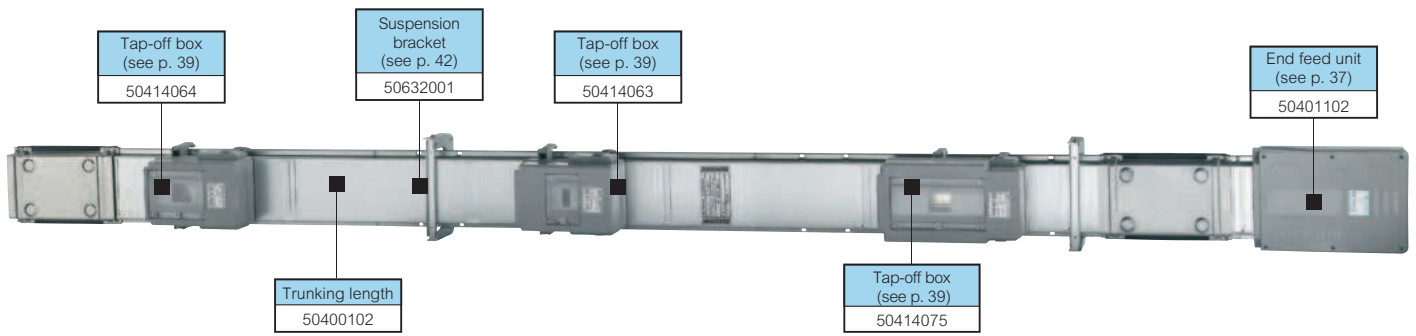

Dimensions and technical information **p. 43-44**
 Measuring bespoke dimensions **p. 49**
 Technical data **p. 52-56**

IP 55 (according to BS EN 60529)
 Flame retardant in compliance with IEC 60332-3. Fully compliant with BS EN 60439-2
 Rated currents are at an average ambient temperature of 40° C (over and above the required standard of 35° C)

Pack	Cat. Nos.		Rating (A)
Trunking lengths – bespoke dimensions (continued)			
Please specify required length when ordering (see p. 49 – how to measure bespoke dimensions)			
1 000 to 1 500 mm lengths with 1 + 1 outlets			
Tap-off outlets in fixed position on both sides			
	Aluminium	Copper	Rating (A)
1	50400141		160
1	50400142	55400142	250
1	50400143	55400143	315
1	50400144	55400144	400
1	50400148		500
1	50400145	55400145	630
1	50400146	55400146	800
1	50400147 ¹	55400147	1 000
600 to 1 500 mm lengths without outlets			
Feeder length. A tap-off point is only possible on the junction between two lengths (see bolt-on tap-off boxes p. 41)			
			Rating (A)
1	50400111		160
1	50400112	55400112	250
1	50400113	55400113	315
1	50400114	55400114	400
1	50400118		500
1	50400115	55400115	630
1	50400116	55400116	800
1	50400117 ¹	55400117	1 000

Pack	Cat. Nos.		Rating (A)
Trunking lengths with fire barriers			
With external fire barriers			
Please specify the required position of the external fire barrier when ordering (see p. 44)			
	Aluminium	Copper	Rating (A)
1	554EFB01		160
1	554EFB01	554EFB01	250
1	554EFB01	554EFB01	315
1	554EFB02	554EFB01	400
1	554EFB02		500
1	554EFB02	554EFB02	630
1	554EFB02	554EFB02	800
1	554EFB02	554EFB02	1 000
With internal fire barriers			
Please specify the required position of the internal fire barrier when ordering (see p. 44)			
			Rating (A)
1	554IFB01		160
1	554IFB02	554IFB01	250
1	554IFB03	554IFB02	315
1	554IFB04	554IFB05	400
1	554IFB06		500
1	554IFB07	554IFB04	630
1	554IFB08	554IFB06	800
1	554IFB09	554IFB07	1 000
Tap-off outlet cover IP 55			
1	50403601		Suitable for all MR versions 6 for each length Weight : 0.10 kg

1 : The 1000 A aluminium is supplied painted as standard

Key : How to select the correct configuration and finish
 All examples on this page show 4 conductor galvanised lengths
 No. of conductors and finish is dictated by the red number
 0 = 4 conductors. Galvanised 2 = 4 conductors. Painted
 1 = 5 conductors. Galvanised 3 = 5 conductors. Painted
 Replace 0 with 1, 2, or 3 if required

MR medium rating busbar

single elbows

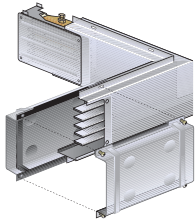

Horizontal elbow – right hand

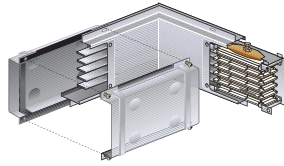

Horizontal elbow – left hand

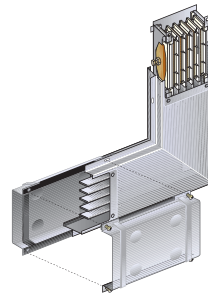

Vertical elbow – right hand

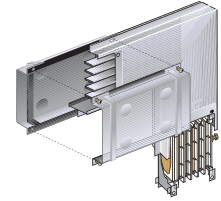

Vertical elbow – left hand



Dimensions and technical information **p. 44**
Measuring bespoke dimensions **p. 49**

MR is fully compliant with BS EN 60439-2

Rated currents are at an average ambient temperature of 40° C (over and above the required standard of 35° C)

Angles are 90° as standard. Other angles available on request. IP 55 (according to BS EN 60529)

Pack	Cat. Nos.		Single elbows – standard dimensions (300 + 300 mm)		
	Aluminium	Copper	Rating (A)	Weight (kg) Aluminium Copper	
1	50400301		160	8.1	–
1	50400302	55400302	250	8.2	9.2
1	50400303	55400303	315	8.4	9.6
1	50400304	55400304	400	14.5	11.0
1	50400308		500	14.9	–
1	50400305	55400305	630	15.4	18.7
1	50400306	55400306	800	15.7	21.4
1	50400307 ¹	55400307	1000	16.0	23.3
			Horizontal elbow – left hand		
			Rating (A)	Weight (kg) Aluminium Copper	
1	50400311		160	8.1	–
1	50400312	55400312	250	8.2	9.2
1	50400313	55400313	315	8.4	9.6
1	50400314	55400314	400	14.5	11.0
1	50400318		500	14.9	–
1	50400315	55400315	630	15.4	18.7
1	50400316	55400316	800	15.7	21.4
1	50400317 ¹	55400317	1000	16.0	23.3
			Vertical elbow – right hand		
			Rating (A)	Weight (kg) Aluminium Copper	
1	50400401		160	8.1	–
1	50400402	55400402	250	8.2	9.2
1	50400403	55400403	315	8.4	9.6
1	50400404	55400404	400	14.5	11.0
1	50400408		500	14.9	–
1	50400405	55400405	630	15.4	18.7
1	50400406	55400406	800	15.7	21.4
1	50400407 ¹	55400407	1000	16.0	23.3
			Vertical elbow – left hand		
			Rating (A)	Weight (kg) Aluminium Copper	
1	50400411		160	8.1	–
1	50400412	55400412	250	8.2	9.2
1	50400413	55400413	315	8.4	9.6
1	50400414	55400414	400	14.5	11.0
1	50400418		500	14.9	–
1	50400415	55400415	630	15.4	18.7
1	50400416	55400416	800	15.7	21.4
1	50400417 ¹	55400417	1000	16.0	23.3

Pack	Cat. Nos.		Single elbows – bespoke dimensions
	Aluminium	Copper	Please specify required length when ordering
			Horizontal elbow – right hand 250 to 900 mm per arm
			Rating (A)
1	50400321		160
1	50400322	55400322	250
1	50400323	55400323	315
1	50400324	55400324	400
1	50400328		500
1	50400325	55400325	630
1	50400326	55400326	800
1	50400327 ¹	55400327	1000
			Horizontal elbow – left hand 250 to 900 mm per arm
			Rating (A)
1	50400331		160
1	50400332	55400332	250
1	50400333	55400333	315
1	50400334	55400334	400
1	50400338		500
1	50400335	55400335	630
1	50400336	55400336	800
1	50400337 ¹	55400337	1000
			Vertical elbow – right hand 300 to 900 mm per arm
			Rating (A)
1	50400421		160
1	50400422	55400422	250
1	50400423	55400423	315
1	50400424	55400424	400
1	50400428		500
1	50400425	55400425	630
1	50400426	55400426	800
1	50400427 ¹	55400427	1000
			Vertical elbow – left hand 300 to 900 mm per arm
			Rating (A)
1	50400431		160
1	50400432	55400432	250
1	50400433	55400433	315
1	50400434	55400434	400
1	50400438		500
1	50400435	55400435	630
1	50400436	55400436	800
1	50400437 ¹	55400437	1000

Key : How to select the correct configuration and finish
 All examples on this page show 4 conductor galvanised lengths
 No. of conductors and finish is dictated by the red number
 0 = 4 conductors. Galvanised 2 = 4 conductors. Painted
 1 = 5 conductors. Galvanised 3 = 5 conductors. Painted
 Replace 0 with 1, 2, or 3 if required

1 : The 1000 A aluminium is supplied painted as standard

MR medium rating busbar

double elbows

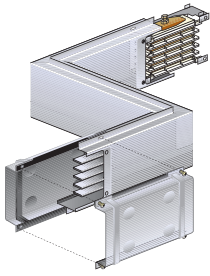

Horizontal elbow – right + left hand

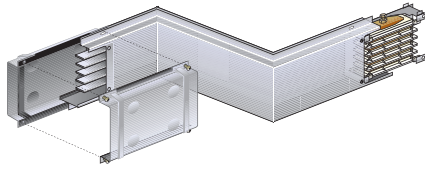

Horizontal elbow – left + right hand

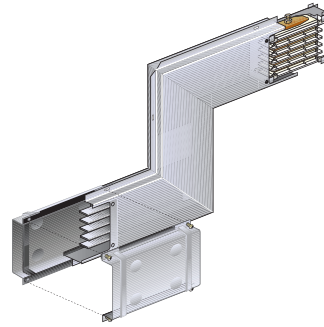

Vertical elbow – right + left hand

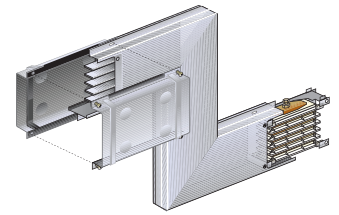





Vertical elbow – left + right hand

 **Dimensions and technical information p. 44**
Measuring bespoke dimensions p. 49

MR is fully compliant with BS EN 60439-2
Rated currents are at an average ambient temperature of 40° C (over and above the required standard of 35° C)
Angles are 90° as standard. Other angles available on request. IP 55 (according to BS EN 60529)

Pack	Cat. Nos.		Double elbows – standard dimensions (300 + 300 + 300 mm)		
	Aluminium	Copper	Rating (A)	Weight (kg)	
				Aluminium	Copper
1	50400341		160	10-29	–
1	50400342	55400342	250	10-55	12-23
1	50400343	55400343	315	11-06	12-97
1	50400344	55400344	400	18-37	15-72
1	50400348		500	19-50	–
1	50400345	55400345	630	20-55	25-77
1	50400346	55400346	800	21-20	30-88
1	50400347 ¹	55400347	1000	21-80	34-55
			Horizontal elbow – right + left hand		
			Rating (A)	Weight (kg)	
				Aluminium	Copper
1	50400351		160	10-29	–
1	50400352	55400352	250	10-55	12-23
1	50400353	55400353	315	11-06	12-97
1	50400354	55400354	400	18-37	15-72
1	50400358		500	19-50	–
1	50400355	55400355	630	20-55	25-77
1	50400356	55400356	800	21-20	30-88
1	50400357 ¹	55400357	1000	21-80	34-55
			Horizontal elbow – left + right hand		
			Rating (A)	Weight (kg)	
				Aluminium	Copper
1	50400441		160	10-29	–
1	50400442	55400442	250	10-55	12-23
1	50400443	55400443	315	11-06	12-97
1	50400444	55400444	400	18-37	15-72
1	50400448		500	19-50	–
1	50400445	55400445	630	20-55	25-77
1	50400446	55400446	800	21-20	30-88
1	50400447 ¹	55400447	1000	21-80	34-55
			Vertical elbow – right + left hand		
			Rating (A)	Weight (kg)	
				Aluminium	Copper
1	50400461		160	10-29	–
1	50400462	55400462	250	10-55	12-23
1	50400463	55400463	315	11-06	12-97
1	50400464	55400464	400	18-37	15-72
1	50400468		500	19-50	–
1	50400465	55400465	630	20-55	25-77
1	50400466	55400466	800	21-20	30-88
1	50400467 ¹	55400467	1000	21-80	34-55
			Vertical elbow – left + right hand		
			Rating (A)	Weight (kg)	
				Aluminium	Copper
1	50400451		160	10-29	–
1	50400452	55400452	250	10-55	12-23
1	50400453	55400453	315	11-06	12-97
1	50400454	55400454	400	18-37	15-72
1	50400458		500	19-50	–
1	50400455	55400455	630	20-55	25-77
1	50400456	55400456	800	21-20	30-88
1	50400457 ¹	55400457	1000	21-80	34-55

Pack	Cat. Nos.		Double elbows – bespoke dimensions		
	Aluminium	Copper	Please specify required length when ordering		
			Horizontal elbow – right + left hand		
			250 to 900 mm per arm		
			Rating (A)		
1	50400361		160		
1	50400362	55400362	250		
1	50400363	55400363	315		
1	50400364	55400364	400		
1	50400368		500		
1	50400365	55400365	630		
1	50400366	55400366	800		
1	50400367 ¹	55400367	1000		
			Horizontal elbow – left + right hand		
			250 to 900 mm per arm		
			Rating (A)		
1	50400371		160		
1	50400372	55400372	250		
1	50400373	55400373	315		
1	50400374	55400374	400		
1	50400378		500		
1	50400375	55400375	630		
1	50400376	55400376	800		
1	50400377 ¹	55400377	1000		
			Vertical elbow – right + left hand		
			300 to 900 mm per arm		
			Rating (A)		
1	50400461		160		
1	50400462	55400462	250		
1	50400463	55400463	315		
1	50400464	55400464	400		
1	50400468		500		
1	50400465	55400465	630		
1	50400466	55400466	800		
1	50400467 ¹	55400467	1000		
			Vertical elbow – left + right hand		
			300 to 900 mm per arm		
			Rating (A)		
1	50400471		160		
1	50400472	55400472	250		
1	50400473	55400473	315		
1	50400474	55400474	400		
1	50400478		500		
1	50400475	55400475	630		
1	50400476	55400476	800		
1	50400477 ¹	55400477	1000		

Key : How to select the correct configuration and finish
 All examples on this page show 4 conductor galvanised lengths
 No. of conductors and finish is dictated by the red number
 0 =  4 conductors. Galvanised 2 =  4 conductors. Painted
 1 =  5 conductors. Galvanised 3 =  5 conductors. Painted
 Replace 0 with 1, 2, or 3 if required

1 : The 1000 A aluminium is supplied painted as standard

MR medium rating busbar

combination vertical + horizontal elbows

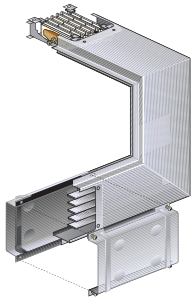

Combination vertical + horizontal elbow right + right hand

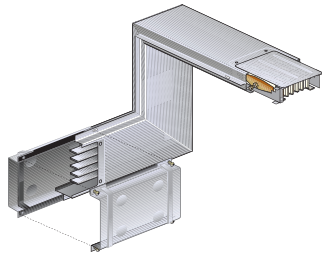

Combination vertical + horizontal elbow right + left hand

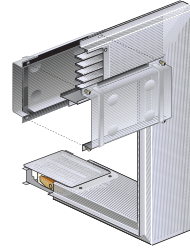

Combination vertical + horizontal elbow left + right hand

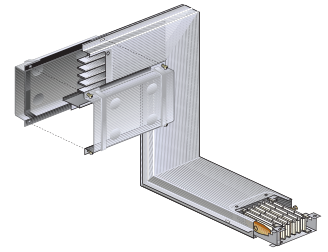

Combination vertical + horizontal elbow left + left hand

Dimensions and technical information p. 44
Measuring bespoke dimensions p. 49

MR is fully compliant with BS EN 60439-2
Rated currents are at an average ambient temperature of 40° C (over and above the required standard of 35° C)
Angles are 90° as standard. Other angles available on request. IP 55 (according to BS EN 60529)

Pack	Cat. Nos.		Combination vertical + horizontal elbows – standard dimensions (300 + 300 + 300 mm)		
	Aluminium	Copper	Rating (A)	Weight (kg)	
				Aluminium	Copper
1	50400501		160	10-29	–
1	50400502	55400502	250	10-55	12-23
1	50400503	55400503	315	11-06	12-97
1	50400504	55400504	400	18-37	15-72
1	50400508		500	19-50	–
1	50400505	55400505	630	20-55	25-77
1	50400506	55400506	800	21-20	30-88
1	50400507 ¹	55400507	1 000	21-80	34-55
			Right hand + left hand		
			Rating (A)	Weight (kg)	
				Aluminium	Copper
1	50400511		160	10-29	–
1	50400512	55400512	250	10-55	12-23
1	50400513	55400513	315	11-06	12-97
1	50400514	55400514	400	18-37	15-72
1	50400518		500	19-50	–
1	50400515	55400515	630	20-55	25-77
1	50400516	55400516	800	21-20	30-88
1	50400517 ¹	55400517	1 000	21-80	34-55
			Left hand + right hand		
			Rating (A)	Weight (kg)	
				Aluminium	Copper
1	50400521		160	10-29	–
1	50400522	55400522	250	10-55	12-23
1	50400523	55400523	315	11-06	12-97
1	50400524	55400524	400	18-37	15-72
1	50400528		500	19-50	–
1	50400525	55400525	630	20-55	25-77
1	50400526	55400526	800	21-20	30-88
1	50400527 ¹	55400527	1 000	21-80	34-55
			Left hand + left hand		
			Rating (A)	Weight (kg)	
				Aluminium	Copper
1	50400531		160	10-29	–
1	50400532	55400532	250	10-55	12-23
1	50400533	55400533	315	11-06	12-97
1	50400534	55400534	400	18-37	15-72
1	50400538		500	19-50	–
1	50400535	55400535	630	20-55	25-77
1	50400536	55400536	800	21-20	30-88
1	50400537 ¹	55400537	1 000	21-80	34-55

Pack	Cat. Nos.		Combination vertical + horizontal elbows – bespoke dimensions		
	Aluminium	Copper	Please specify required length when ordering		
			Right hand + right hand		
			300 to 900 mm per arm		
			Rating (A)		
1	50400541		160		
1	50400542	55400542	250		
1	50400543	55400543	315		
1	50400544	55400544	400		
1	50400548		500		
1	50400545	55400545	630		
1	50400546	55400546	800		
1	50400547 ¹	55400547	1 000		
			Right hand + left hand		
			300 to 900 mm per arm		
			Rating (A)		
1	50400551		160		
1	50400552	55400552	250		
1	50400553	55400553	315		
1	50400554	55400554	400		
1	50400558		500		
1	50400555	55400555	630		
1	50400556	55400556	800		
1	50400557 ¹	55400557	1 000		
			Left hand + right hand		
			300 to 900 mm per arm		
			Rating (A)		
1	50400561		160		
1	50400562	55400562	250		
1	50400563	55400563	315		
1	50400564	55400564	400		
1	50400568		500		
1	50400565	55400565	630		
1	50400566	55400566	800		
1	50400567 ¹	55400567	1 000		
			Left hand + left hand		
			300 to 900 mm per arm		
			Rating (A)		
1	50400571		160		
1	50400572	55400572	250		
1	50400573	55400573	315		
1	50400574	55400574	400		
1	50400578		500		
1	50400575	55400575	630		
1	50400576	55400576	800		
1	50400577 ¹	55400577	1 000		

Key : How to select the correct configuration and finish
 All examples on this page show 4 conductor galvanised lengths
 No. of conductors and finish is dictated by the red number
 0 = 4 conductors. Galvanised 2 = 4 conductors. Painted
 1 = 5 conductors. Galvanised 3 = 5 conductors. Painted
 Replace 0 with 1, 2, or 3 if required

1 : The 1000 A aluminium is supplied painted as standard

MR medium rating busbar

combination horizontal + vertical elbows

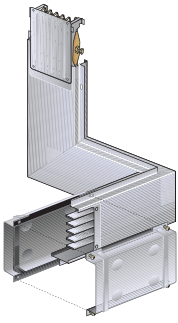

Combination horizontal + vertical elbows right + right hand

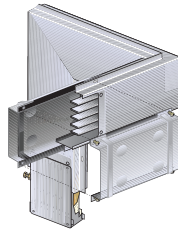

Combination horizontal + vertical elbows right + left hand

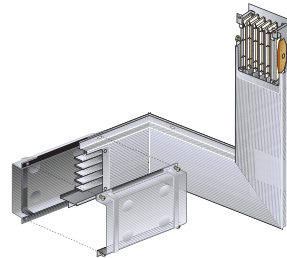

Combination horizontal + vertical elbows left + right hand

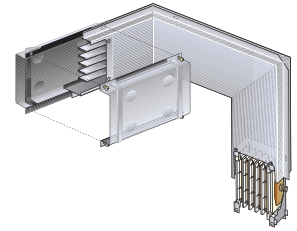

Combination horizontal + vertical elbows left + left hand



Dimensions and technical information **p. 44**
Measuring bespoke dimensions **p. 49**

MR is fully compliant with BS EN 60439-2
Rated currents are at an average ambient temperature of 40° C (over and above the required standard of 35° C)
Angles are 90° as standard. Other angles available on request. IP 55 (according to BS EN 60529)

Pack	Cat. Nos.		Combination horizontal + vertical elbows – standard dimensions (300 + 300 + 300 mm)		
	Aluminium	Copper	Rating (A)	Weight (kg)	
				Aluminium	Copper
1	50400601		160	10.29	–
1	50400602	55400602	250	10.55	12.23
1	50400603	55400603	315	11.06	12.97
1	50400604	55400604	400	18.37	15.72
1	50400608		500	19.50	–
1	50400605	55400605	630	20.55	25.77
1	50400606	55400606	800	21.20	30.88
1	50400607 ¹	55400607	1000	21.80	34.55
			Right hand + left hand		
			Rating (A)	Weight (kg)	
				Aluminium	Copper
1	50400611		160	10.29	–
1	50400612	55400612	250	10.55	12.23
1	50400613	55400613	315	11.06	12.97
1	50400614	55400614	400	18.37	15.72
1	50400618		500	19.50	–
1	50400615	55400615	630	20.55	25.77
1	50400616	55400616	800	21.20	30.88
1	50400617 ¹	55400617	1000	21.80	34.55
			Left hand + right hand		
			Rating (A)	Weight (kg)	
				Aluminium	Copper
1	50400621		160	10.29	–
1	50400622	55400622	250	10.55	12.23
1	50400623	55400623	315	11.06	12.97
1	50400624	55400624	400	18.37	15.72
1	50400628		500	19.50	–
1	50400625	55400625	630	20.55	25.77
1	50400626	55400626	800	21.20	30.88
1	50400627 ¹	55400627	1000	21.80	34.55
			Left hand + left hand		
			Rating (A)	Weight (kg)	
				Aluminium	Copper
1	50400631		160	10.29	–
1	50400632	55400632	250	10.55	12.23
1	50400633	55400633	315	11.06	12.97
1	50400634	55400634	400	18.37	15.72
1	50400638		500	19.50	–
1	50400635	55400635	630	20.55	25.77
1	50400636	55400636	800	21.20	30.88
1	50400637 ¹	55400637	1000	21.80	34.55

Pack	Cat. Nos.		Combination horizontal + vertical elbows – bespoke dimensions		
	Aluminium	Copper	Please specify required length when ordering		
			Right hand + right hand		
			300 to 900 mm per arm		
			Rating (A)		
1	50400641		160		
1	50400642	55400642	250		
1	50400643	55400643	315		
1	50400644	55400644	400		
1	50400648		500		
1	50400645	55400645	630		
1	50400646	55400646	800		
1	50400647 ¹	55400647	1000		
			Right hand + left hand		
			300 to 900 mm per arm		
			Rating (A)		
1	50400651		160		
1	50400652	55400652	250		
1	50400653	55400653	315		
1	50400654	55400654	400		
1	50400658		500		
1	50400655	55400655	630		
1	50400656	55400656	800		
1	50400657 ¹	55400657	1000		
			Left hand + right hand		
			300 to 900 mm per arm		
			Rating (A)		
1	50400661		160		
1	50400662	55400662	250		
1	50400663	55400663	315		
1	50400664	55400664	400		
1	50400668		500		
1	50400665	55400665	630		
1	50400666	55400666	800		
1	50400667 ¹	55400667	1000		
			Left hand + left hand		
			300 to 900 mm per arm		
			Rating (A)		
1	50400671		160		
1	50400672	55400672	250		
1	50400673	55400673	315		
1	50400674	55400674	400		
1	50400678		500		
1	50400675	55400675	630		
1	50400676	55400676	800		
1	50400677 ¹	55400677	1000		

Key : How to select the correct configuration and finish
All examples on this page show 4 conductor galvanised lengths
No. of conductors and finish is dictated by the red number
0 = 4 conductors. Galvanised 2 = 4 conductors. Painted
1 = 5 conductors. Galvanised 3 = 5 conductors. Painted
Replace 0 with 1, 2, or 3 if required

1 : The 1000 A aluminium is supplied painted as standard

MR medium rating busbar

horizontal tees and crossovers

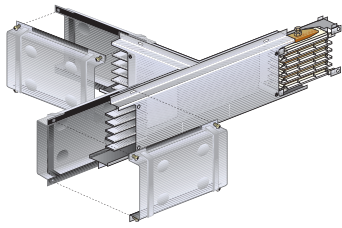

Horizontal tee right hand – female

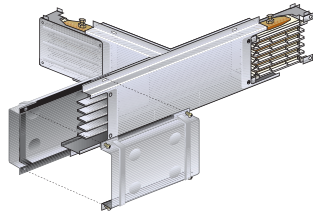

Horizontal tee right hand – male

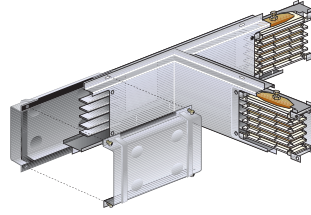

Horizontal tee left hand – female

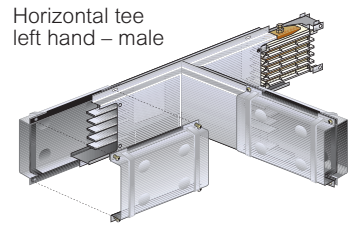

Horizontal tee left hand – male

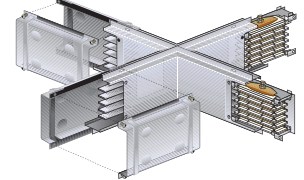

Crossover

Dimensions and technical information p. 45
Measuring bespoke dimensions p. 49

MR is fully compliant with BS EN 60439-2
Rated currents are at an average ambient temperature of 40° C (over and above the required standard of 35° C)
Angles are 90° as standard. Other angles available on request IP 55 (according to BS EN 60529)

Pack	Cat. Nos.		Horizontal tees – standard dimension (300 + 300 + 300 mm)		
	Aluminium	Copper	Rating (A)	Weight (kg)	
				Aluminium	Copper
1	50400701		160	11.2	–
1	50400702	55400702	250	11.4	12.8
1	50400703	55400703	315	11.8	13.4
1	50400704	55400704	400	18.4	15.7
1	50400708		500	19.5	–
1	50400705	55400705	630	20.0	24.4
1	50400706	55400706	800	20.5	28.5
1	50400707 ¹	55400707	1000	21.0	31.3
Right hand – male					
			Rating (A)	Weight (kg)	
				Aluminium	Copper
1	50400711		160	11.2	–
1	50400712	55400712	250	11.4	12.8
1	50400713	55400713	315	11.8	13.4
1	50400714	55400714	400	18.4	15.7
1	50400718		500	19.5	–
1	50400715	55400715	630	20.0	24.4
1	50400716	55400716	800	20.5	28.5
1	50400717 ¹	55400717	1000	21.0	31.3
Left hand – female					
			Rating (A)	Weight (kg)	
				Aluminium	Copper
1	50400721		160	11.2	–
1	50400722	55400722	250	11.4	12.8
1	50400723	55400723	315	11.8	13.4
1	50400724	55400724	400	18.4	15.7
1	50400728		500	19.5	–
1	50400725	55400725	630	20.0	24.4
1	50400726	55400726	800	20.5	28.5
1	50400727 ¹	55400727	1000	21.0	31.3
Left hand – male					
			Rating (A)	Weight (kg)	
				Aluminium	Copper
1	50400731		160	11.2	–
1	50400732	55400732	250	11.4	12.8
1	50400733	55400733	315	11.8	13.4
1	50400734	55400734	400	18.4	15.7
1	50400738		500	19.5	–
1	50400735	55400735	630	20.0	24.4
1	50400736	55400736	800	20.5	28.5
1	50400737 ¹	55400737	1000	21.0	31.3

Pack	Cat. Nos.	
	Aluminium	Copper
1	50400741	
1	50400742	55400742
1	50400743	55400743
1	50400744	55400744
1	50400748	
1	50400745	55400745
1	50400746	55400746
1	50400747 ¹	55400747
1	50400751	
1	50400752	55400752
1	50400753	55400753
1	50400754	55400754
1	50400758	
1	50400755	55400755
1	50400756	55400756
1	50400757 ¹	55400757
1	50400761	
1	50400762	55400762
1	50400763	55400763
1	50400764	55400764
1	50400768	
1	50400765	55400765
1	50400766	55400766
1	50400767 ¹	55400767
1	50400771	
1	50400772	55400772
1	50400773	55400773
1	50400774	55400774
1	50400778	
1	50400775	55400775
1	50400776	55400776
1	50400777 ¹	55400777

Horizontal tees – bespoke dimensions

Please specify required length when ordering
Arms can be 250 to 900 mm

Right hand – female

Rating (A)
160
250
315
400
500
630
800
1000

Right hand – male

Rating (A)
160
250
315
400
500
630
800
1000

Left hand – female

Rating (A)
160
250
315
400
500
630
800
1000

Left hand – male

Rating (A)
160
250
315
400
500
630
800
1000

Crossovers – standard dimension (300 + 300 + 300 + 300 mm)

	Aluminium	Copper	Rating (A)	Weight (kg)	
				Aluminium	Copper
1	50403001		160	15.5	–
1	50403002	55403002	250	15.7	17.6
1	50403003	55403003	315	16.1	18.4
1	50403004	55403004	400	27.5	21.1
1	50403008		500	29.3	–
1	50403005	55403005	630	29.1	35.2
1	50403006	55403006	800	29.5	40.2
1	50403007 ¹	55403007	1000	29.9	43.7

1 : The 1000 A aluminium is supplied painted as standard

Key : How to select the correct configuration and finish
All examples on this page show 4 conductor galvanised lengths
No. of conductors and finish is dictated by the red number
0 = 4 conductors. Galvanised 2 = 4 conductors. Painted
1 = 5 conductors. Galvanised 3 = 5 conductors. Painted
Replace 0 with 1, 2, or 3 if required

MR medium rating busbar feed units

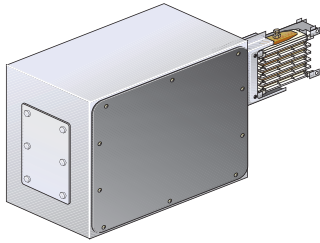

Feed unit left end

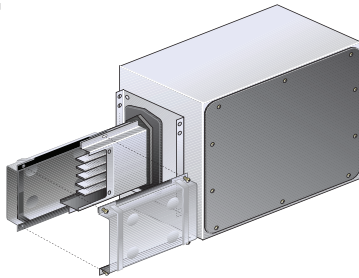

Feed unit right end

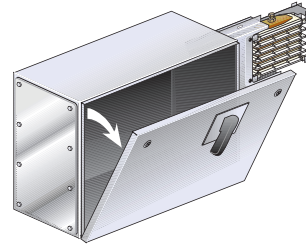

Right end up feed unit with AC23 switch disconnecter



End stop

Dimensions and technical information p. 45
Measuring bespoke dimensions p. 49

MR is fully compliant with BS EN 60439-2
 Rated currents are at an average ambient temperature of 40° C (over and above the required standard of 35° C)
 IP 55 (according to BS EN 60529)

Pack	Cat. Nos.		Feed units		
			Metal end feed units		
			For plates and hole dimensions refer to switchboard-transformer feed units with same rating (p. 38)		
			Left end		
	Aluminium	Copper	Rating (A)	Weight (kg)	
				Aluminium	Copper
1	50401131		160	17.74	—
1	50401132	55401132	250	17.76	18.47
1	50401133	55401133	315	17.83	18.70
1	50401134	55401134	400	23.22	19.58
1	50401138		500	23.20	—
1	50401135	55401135	630	23.63	26.07
1	50401136	55401136	800	23.70	27.80
1	50401137	55401137	1000	24.00	29.03
			Right end		
			Rating (A)	Weight (kg)	
				Aluminium	Copper
1	50401121		160	16.64	—
1	50401122	55401122	250	16.76	17.37
1	50401123	55401123	315	17.03	17.70
1	50401124	55401124	400	18.32	18.88
1	50401128		500	20.00	—
1	50401125	55401125	630	19.43	21.17
1	50401126	55401126	800	19.80	23.30
1	50401127	55401127	1000	20.20	24.83
			Plastic end feed units		
			Terminals accept cables up to 150 mm ² . For higher ratings attach cable lugs to spreaders provided		
			Left end		
	Aluminium	Copper	Rating (A)	Weight (kg)	
				Aluminium	Copper
1	50401111		160	6.80	—
1	50401112	55401112	250	6.85	7.20
			Right end		
			Rating (A)	Weight (kg)	
				Aluminium	Copper
1	50401101		160	5.70	—
1	50401102	55401102	250	5.85	6.10

Pack	Cat. Nos.		Feed units (continued)		
			End feed unit with AC23 switch disconnecter		
			This feed unit allows isolation of the line for maintenance		
			Right end up		
	Aluminium	Copper	Rating (A)	Weight (kg)	
				Aluminium	Copper
1	50403401		160	17.94	—
1	50403402	55403402	250	18.10	19.12
1	50403403	55403403	315	18.86	19.40
1	50403404	55403404	400	21.79	20.34
1	50403408		500	22.42	—
1	50403405	55403405	630	23.64	26.88
1	50403406	55403406	800	24.95	28.67
1	50403407	55403407	1000	26.50	29.95
			Right end down		
			Rating (A)	Weight (kg)	
				Aluminium	Copper
1	50403411		160	17.94	—
1	50403412	55403412	250	18.10	19.12
1	50403413	55403413	315	18.86	19.40
1	50403414	55403414	400	21.79	20.34
1	50403418		500	22.42	—
1	50403415	55403415	630	23.64	26.88
1	50403416	55403416	800	24.95	28.67
1	50403417	55403417	1000	26.50	29.95
			Left end up		
			Rating (A)	Weight (kg)	
				Aluminium	Copper
1	50403421		160	17.94	—
1	50403422	55403422	250	18.10	19.12
1	50403423	55403423	315	18.86	19.40
1	50403424	55403424	400	21.79	20.34
1	50403428		500	22.42	—
1	50403425	55403425	630	23.64	26.88
1	50403426	55403426	800	24.95	28.67
1	50403427	55403427	1000	26.50	29.95
			Left end down		
			Rating (A)	Weight (kg)	
				Aluminium	Copper
1	50403431		160	17.94	—
1	50403432	55403432	250	18.10	19.12
1	50403433	55403433	315	18.86	19.40
1	50403434	55403434	400	21.79	20.34
1	50403438		500	22.42	—
1	50403435	55403435	630	23.64	26.88
1	50403436	55403436	800	24.95	28.67
1	50403437	55403437	1000	26.50	29.95

End stops

Ensure IP 55 protection at the end of the run
 For right and left feed units
 160 – 315 A - for aluminium
 250 – 400 A - for copper
 400 – 1000 A - for aluminium
 630 – 1000 A - for copper

Key : How to select the correct configuration and finish
 All examples on this page show 4 conductor galvanised lengths
 No. of conductors and finish is dictated by the red number
0 = 4 conductors. Galvanised **2** = 4 conductors. Painted
1 = 5 conductors. Galvanised **3** = 5 conductors. Painted
 Replace 0 with 1, 2, or 3 if required

1 50403101

1 50403102

MR medium rating busbar

feed units (continued), in-line bus switcher and reducers

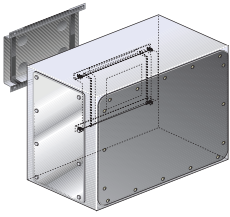

Centre feed unit

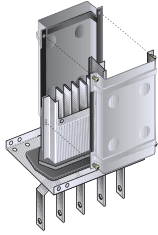

Switchboard-transformer feed units right hand

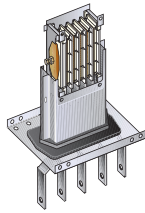

Switchboard-transformer feed units left hand

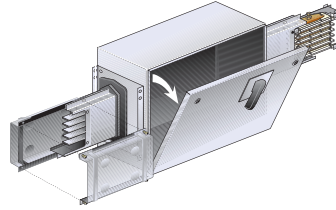

In-line bus switch right hand

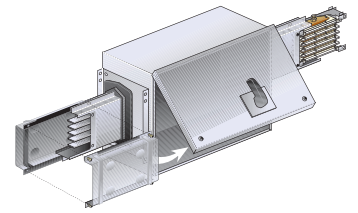

In-line bus switch left hand



Dimensions and technical information p. 45-46

MR is fully compliant with BS EN 60439-2

Rated currents are at an average ambient temperature of 40° C (over and above the required standard of 35° C)
IP 55 (according to BS EN 60529)

Pack	Cat. Nos.		Feed units (continued)		
			Centre feed units		
			Feeds a trunking system from an intermediate position along the run. Also used to reduce the volt drop of the line		
	Aluminium	Copper	Rating (A)	Weight (kg)	
1	50401201		160	Aluminium	Copper
1	50401202	55401202	250	17-27	—
1	50401203	55401203	315	18-13	19-12
1	50401204	55401204	400	18-88	19-40
1	50401208		500	22-06	20-34
1	50401205	55401205	630	22-65	—
1	50401206	55401206	800	23-24	26-88
1	50401207	55401207	1000	24-02	28-67
				25-70	29-95
			Switchboard-transformer feed units		
			Feed unit for direct connection of the busbar to a switchboard or to the low voltage terminals of a distribution transformer		
			Right hand		
			Rating (A)	Weight (kg)	
1	50401001		160	Aluminium	Copper
1	50401002	55401002	250	4-9	—
1	50401003	55401003	315	5-1	5-7
1	50401004	55401004	400	5-3	6-0
1	50401008		500	6-4	9-2
1	50401005	55401005	630	6-9	—
1	50401006	55401006	800	7-5	9-3
1	50401007	55401007	1000	7-9	11-4
				8-3	12-9
			Left hand		
			Rating (A)	Weight (kg)	
1	50401011		160	Aluminium	Copper
1	50401012	55401012	250	6-0	—
1	50401013	55401013	315	6-1	6-7
1	50401014	55401014	400	6-2	7-0
1	50401018		500	11-3	7-8
1	50401015	55401015	630	11-4	—
1	50401016	55401016	800	11-7	14-2
1	50401017	55401017	1000	11-8	15-9
				12-5	17-1

Pack	Cat. Nos.		In-line bus switches		
			Allows disconnection of part of a line, while the other is live		
			Right hand		
			Rating (A)	Weight (kg)	
	Aluminium	Copper		Aluminium	Copper
1	50401701		160	23-54	—
1	50401702	55401702	250	23-56	24-27
1	50401703	55401703	315	23-63	24-50
1	50401704	55401704	400	29-32	25-38
1	50401708		500	29-50	—
1	50401705	55401705	630	29-73	32-17
1	50401706	55401706	800	29-80	33-90
1	50401707	55401707	1000	32-11	35-13
			Left hand		
			Rating (A)	Weight (kg)	
1	50401721		160	Aluminium	Copper
1	50401722	55401722	250	23-54	—
1	50401723	55401723	315	23-56	24-27
1	50401724	55401724	400	23-63	24-50
1	50401728		500	29-32	25-38
1	50401725	55401725	630	29-50	—
1	50401726	55401726	800	29-73	32-17
1	50401727	55401727	1000	29-80	33-90
				32-11	35-13

Key : How to select the correct configuration and finish
 All examples on this page show 4 conductor galvanised lengths
 No. of conductors and finish is dictated by the red number
 0 = 4 conductors. Galvanised 2 = 4 conductors. Painted
 1 = 5 conductors. Galvanised 3 = 5 conductors. Painted
 Replace 0 with 1, 2, or 3 if required

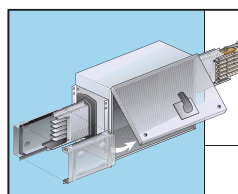







Rating reducers with disconnecter and fuse holder also available

Contact us on +44 (0) 845 600 6266

MR tap-off boxes : plug-in type up to 32 A



32 A plug-in tap-offs – Empty

Energy withstand 400 · 10³ A²s

Type 1 – Max. power losses 16 W						Type 2 – Max. power losses 20 W							
	Complete with 3 x CH10 fuse holders		Transparent hinged door and 4 mod. DIN rail		With 8 mod. DIN rail		Transparent hinged door and 8 mod. DIN rail		Transparent hinged door and 8 mod. DIN rail. Plus 3 N + 3 PE terminals		With 12 mod. DIN rail		Transparent hinged door and 12 mod. DIN rail
Cat. Nos.	50414062	50414063	50414061	50414064	50414241	50414071	50414075						
Weight (kg)	1.75	1.7	1.6	1.7	1.94	1.9	2.05						





32 A plug-in tap-offs – fitted complete with TYPE B MCBs

Energy withstand 400 · 10³ A²s

Type 1 – Max. power losses 16 W		Rating		3 x 1P	3 x (1P + N)	3P	4P
	Transparent hinged door and 8 mod. DIN rail	10 A	Cat. Nos.	50414101	50414102	50414103	–
			Weight (kg)	2.28	2.18	2.23	–
	Transparent hinged door and 4 mod. DIN rail	16 A	Cat. Nos.	–	–	50414129	50414130
			Weight (kg)	–	–	2.15	2.29
	Transparent hinged door and 8 mod. DIN rail. Plus 3 N + 3 PE terminals	16 A	Cat. Nos.	50414123	50414124	50414125	50414126
			Weight (kg)	2.46	2.38	2.42	2.56

32 A plug-in tap-offs – fitted complete with TYPE C MCBs

Energy withstand 400 · 10³ A²s

Type 1 – Max. power losses 16 W		Rating		3 x 1P	3 x (1P + N)	3P	4P	Ready for MCB
	Transparent hinged door and 4 mod. DIN rail	16 A	Cat. Nos.	–	–	50414127	50414128	–
			Weight (kg)	–	–	2.15	2.29	–
		32 A	Cat. Nos.	–	–	50414143	50414144	–
			Weight (kg)	–	–	2.18	2.36	–
	Transparent hinged door and 8 mod. DIN rail. Plus 3 N + 3 PE terminals	32 A	Cat. Nos.	–	–	50414141	50414142	–
			Weight (kg)	–	–	2.48	2.65	–
Type 2 – Max. power losses 20 W								
	Transparent hinged door and 8 mod. DIN rail. Plus 1 x 16 A 3P socket	16 A	Cat. Nos.	–	–	50414186	50414187	–
			Weight (kg)	–	–	2.78	2.92	–
		32 A	Cat. Nos.	–	–	50414191	50414192	–
			Weight (kg)	–	–	2.91	3.06	–
	Transparent hinged door and 8 mod. DIN rail. Plus 2 x 16 A 3P sockets	16 A	Cat. Nos.	–	–	50414184	50414185	50414282
			Weight (kg)	–	–	3.14	3.23	2.49
		32 A	Cat. Nos.	–	–	–	–	50414291
			Weight (kg)	–	–	–	–	2.59
	Transparent hinged door and 8 mod. DIN rail. Plus 3 x 16 A 2P + E sockets	16 A	Cat. Nos.	50414181	50414182	50414183	–	50414281
			Weight (kg)	3.05	3.2	3.18	–	2.55

MR tap-off boxes : plug-in type 32-630 A

MR tap-off boxes from 10 to 1 000 A can accommodate different protection devices, including fuses, MCBs or MCCBs. Can be operated when energised and under load conditions up to a rating of 32 A due to the integration of an isolating device within the cover. All insulating plastic components comply with the incandescent wire test (EN 60695-2-1) and have a V2 self extinguishing degree (UL94). Standard degree of protection is IP 55 without using additional protection kits. For dimensions, technical information and mounting instructions **see p. 47-48**

Plug-in tap-offs with fuse carriers (or empty) 63-400 A

	TYPE 3		TYPE 4					TYPE 5		
Rating	32 A	63 A	100 A	125 A		160 A	250 A	400 A		
Fuse Carrier	CH10 (Ø10·3 x 38)	TIA / TIS	TCP	Empty	NH 0	NH 00	NH 0	NH 1	(Neutral section 50%)	
									Empty	NH 1
Cat. Nos.	55655051	55055062	55055063	55055055	55055053	55055057	50404004	55655057	55655059	55655058
Weight (kg)	0·85	3·2	3·3	2·9	3·35	3·35	3·6	14·9	14·3	15·8

Plug-in tap-offs fitted with DIN rail and transparent hinged window 63-400 A

		TYPE 4				TYPE 5	
		Can fit some MCCBs		Not suitable for MCCBs			
Rating		4 mod. DIN rail	8 mod. DIN rail	8 mod. DIN rail	11 mod. DIN rail	7 mod. DIN rail	11 + 11 mod. DIN rail
63 A	Cat. Nos.	–	–	55055086	55055088	–	–
	Weight (kg)	–	–	3·2	3·6	–	–
125 A	Cat. Nos.	55055066	55055077	55055056	55055068	–	–
	Weight (kg)	3·0	3·0	3·2	3·6	–	–
160 A	Cat. Nos.	50404024	–	–	–	–	–
	Weight (kg)	3·6	–	–	–	–	–
400 A	Cat. Nos.	–	–	–	–	55055070	55055071
	Weight (kg)	–	–	–	–	13·4	15·3

Plug-in heavy duty metal tap-offs 63-630 A

		TYPE 6			TYPE 7	TYPE 8	
These PE + FE tap-off boxes have separate terminals for the two parallel earths (casing and conductor) PE = protection earth FE = functional earth							
	Rating	63 A	125 A	160 A	250 A	400 A	630 A
Empty version	Cat. Nos.	50414001	50414002	50414003	50414004	–	50414005
	Weight (kg)	8·60	8·80	8·80	23	–	25
With fuse holder	Cat. Nos.	50414021 CH22 (Ø22 x 58)	50414022 NH 00	50414023 NH 00	50414024 NH 2	50414026 NH 2	50414025 NH 3
	Weight (kg)	8·75	8·90	9·10	25	33	33
With switch disconnecter and fuseholder (AC23)	Cat. Nos.	50411601 NH 00	50411622 NH 00	50411623 NH 0	50411624 NH 1	50411625 NH 2	50411646 NH 3
	Weight (kg)	9·50	9·70	9·70	30	38	38



For dimensions, technical information and mounting instructions **see p. 47-48**

MR tap-off boxes : plug-in type 125-630 A - fully equipped

bolt-on type 630-1 000 A

Plug-in type

Fully equipped tap-offs – toggle handle MCCBs : 25-125 A

Tap-off rating	Breaker rating	3 pole MCCB with toggle handle	4 pole MCCB with toggle handle
125 A	25 A	55055066M3TA	55055077M4TA
	40 A	55055066M3TB	55055077M4TB
	63 A	55055066M3TC	55055077M4TC
	100 A	55055066M3TD	55055077M4TD
	125 A	55055066M3TE	55055077M4TE

MCCBs, R type and J type fuse carriers that meet EDF regulations are also available

**Contact us on
+44 (0) 845 600 6266**

Tap-off boxes can be supplied with Castel locks

**Contact us on
+44 (0) 845 600 6266**

Fully equipped tap-offs – rotary handle MCCBs : 25-630 A¹

Tap-off rating	Breaker rating	3 pole MCCB with rotary handle	4 pole MCCB with rotary handle	With free issue MCCB
125 A	25 A	50414003M3RA	50414003M4RA	50414003MFA
	40 A	50414003M3RB	50414003M4RB	50414003MFB
	63 A	50414003M3RC	50414003M4RC	50414003MFC
	100 A	50414003M3RD	50414003M4RD	50414003MFD
	125 A	50414003M3RE	50414003M4RE	50414003MFE
	160 A	50414003M3RF	50414003M4RF	50414003MFF
250 A	200 A	50414003M3RG	50414003M4RG	50414003MFG
	250 A	50414003M3RH	50414003M4RH	50414003MFH
630 A	400 A	50414003M3RI	50414003M4RI	50414003MFI
	630 A	50414003M3RJ	50414003M4RJ	50414003MFJ

Fully equipped tap-offs – with protection and multifunction meters : 63-160 A¹

Tap-off rating	Breaker rating	3 pole MCCB with multifunction meter	Fusible tap-off with multifunction meter
160 A	63 A	50414003M3MC	50414023FMC
	100 A	50414003M3MD	50414023FMD
	125 A	50414003M3ME	50414023FME
	160 A	50414003M3MF	50414023FMF

¹ : For MCCB technical data, see p. 118-125

Bolt-on type

Bolt-on tap-offs – with switch disconnecter and fuse holder (AC23)

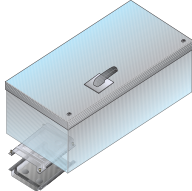
	Positioned in the joint between straight lengths As this connection affects live conductors, it cannot be carried out when the line is live – the line must be isolated	Busbar rating		Tap-off size		
				630 A – NH 3 TYPE 9	800 A – NH 4 TYPE 10	1 000 A – NH 4 TYPE 10
 Busbar system		Aluminium	630 A	Cat. Nos. 50401801	–	–
			Weight (kg)	59	–	–
			800 A	Cat. Nos. 50401802	50401804	–
			Weight (kg)	59	89	–
			1 000 A	Cat. Nos. 50401803	50401805	50401806
			Weight (kg)	59	89	89
Copper		Copper	630 A	Cat. Nos. 55401801	–	–
			Weight (kg)	59	–	–
			800 A	Cat. Nos. 55401802	55401804	–
			Weight (kg)	59	89	–
			1 000 A	Cat. Nos. 55401803	55401805	55401806
			Weight (kg)	59	89	89



For dimensions, technical information and mounting instructions see p. 47-48

MR medium rating busbar

fixing accessories

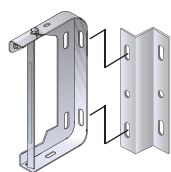

50632001 +
50632205



50403711

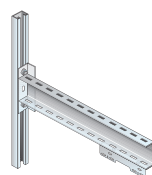

50632212

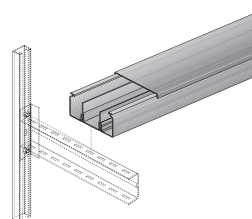

50630110

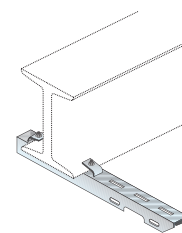

50632210 +
50632211



50403712

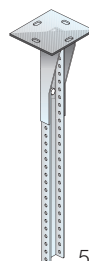

50632201 + 50632202

Dimensions and technical information p. 49
Measuring special dimensions p. 49

The MR series offers a wide range of brackets and fixing accessories that enable quick and simple installation for a wide range of applications. The MR series can be mounted on horizontal or vertical surfaces or mounted directly on to beams. Various spacers, spring suspension hangers and adjustable arms are available to meet the requirements of complex installations

Pack	Cat. Nos.	Fixing accessories for general and rising mains applications	Pack	Cat. Nos.	Fixing accessories for other applications
		Suspension brackets			Wall fixing bracket
		Use 1 bracket every 2 m			Adjustable height and depth arm. Bracket holder can be coupled with MS and MR brackets
1	50632001	Weight : 0.55 kg For use with aluminium rated 160, 250, 315 A and copper rated 250, 315, 400 A	1	50632212	Length (m) Weight (kg) Load on end point
1	50632003	Weight : 0.60 kg For use with aluminium rated 400, 500, 630, 800 A and copper rated 630, 800, 1 000 A	1	50632213	0.45 2.80 pmax=80 kg
		Wall spacer	1	50632214	0.55 3.00 pmax=68 kg
		Used when suspension bracket is fixed directly to the wall			0.75 3.50 pmax=50 kg
1	50632205	Weight : 0.05 kg			Ceiling fixing bracket kit
		Suspension hanger for rising main	1	50632201	Comprises a base to be fixed to the ceiling and various length struts that accept MR brackets
		For vertical trunking lengths. Suitable for rising mains up to 4 m and for weights up to 300 kg			Base
		Must be used in conjunction with Cat. Nos. 50632001 or 50632003			Length (m) Weight (kg)
		1 bracket at the base of the rising main			- 2.80
		Maximum use distance 4 m			Strut
1	50403711	Weight : 1.05 kg	1	50632202	Length (m) Weight (kg)
		Spring suspension hanger for rising main	1	50632203	0.50 3.00
		Use 1 hanger every 300 kg (see weight table, p. 148-149)	1	50632204	1.00 3.50
		Minimum use distance 4 m	1		2.00 3.50
1	50403712	Weight : 1.20 kg			Beam fixing bracket
					Comprises a beam shelf base and two beam clamps
					Beam shelf base
					Length (m) Weight (kg) Load on end point
			1	50632210	0.54 0.90 pmax=65 kg
			1	50632211	Beam clamp
					Triple cable channel
			1	50630110	110 x 60 mm with 3 sectors. PVC Length : 3 m

MR medium rating busbar

technical information

General features

MR is fully compliant with BS EN 60439-2, specifically, the rated current of Zucchini busbar trunking systems is always rated at the average ambient temperature of 40°C (the Standard requires 35°C), thus offering the market suitably oversized products

The busbar casing is made from hot-dipped galvanised sheet steel and forms a high strength outer structure, which also serves as the protective conductor (PE) for the MR version

NOTE : 1000 A is supplied painted as standard

The individual conductors are made from either electrolytic copper or electro tin-plated aluminium. Standard MR trunking is supplied with four equal size conductors (TP and N +PE) whereas the optional 5 conductor version includes an additional integral 100% earth bar (TP and N +E)

The degree of protection is IP 55 throughout the system

The normal recommended fixing centres for the MR range is 2.0 m

The jointing of MR lengths is done by overlapping two lengths and fastening the special locating screws. The 'monobloc' joint is then tightened by a double headed shear bolt to complete the electrical connection. A joint cover is then positioned to complete the joint

Trunking lengths – 3 m

The components and features of MR straight lengths are :

- a casing made of Senzimir quality galvanised steel used as protective earth (PE). NOTE : 1000 A is supplied painted as standard
- overall dimensions : 75 to 135 x 196 mm
- painted casing available on request (contact us on +44 (0) 845 600 6266)
- number of conductors : 4 with the same section (3P + N) with PE made from the casing or 5 when using MR full (3P + N + PE), available in the aluminium or electrolytic copper version with 99.9% purity
- conductors insulators are made of fiberglass reinforced plastic material, ensuring a V1 self-extinguishing degree (according to UL 94), in compliance with the glow-wire test according to IEC 60695-2-10
- tap-off outlets with a constant centre distance of 1 m on both sides of the busbar (3 + 3 outlets every 3 m), set up for being connected to plug-in type tap-off boxes. These outlets open and close automatically when inserting or pulling out a tap-off box
- 'monobloc' electric junction system made with a silver coated copper plate system to connect conductors and PE in a fast and reliable way. The 'monobloc' has shear-head bolts with a preset torque setting which ensure good, long-lasting electrical continuity
- all components and accessories in the MR range are IP 55
- the whole busbar is flame retardant in compliance with the IEC 60332-3 standard

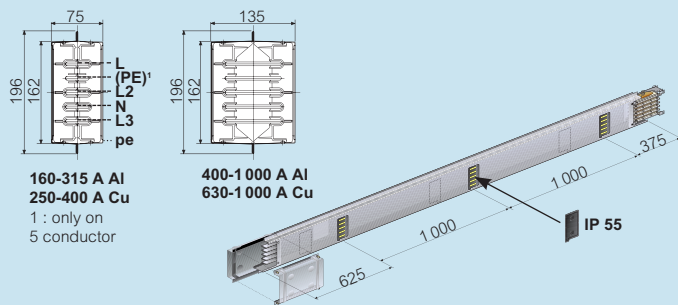

Trunking lengths – 3 m with 5 outlets on one side only

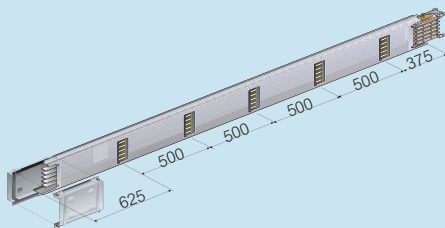

Trunking length – 3 m without outlets

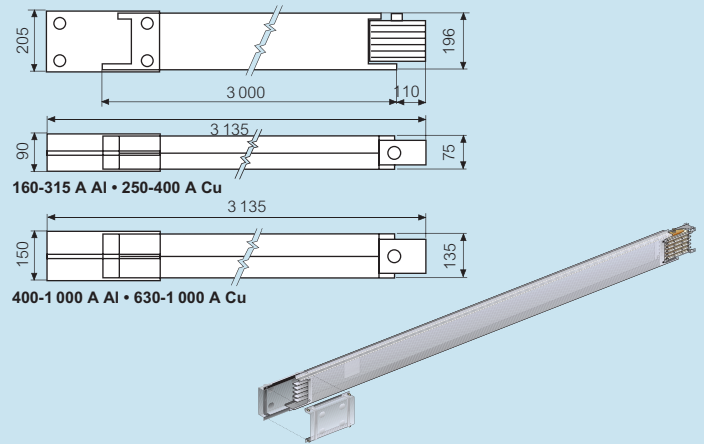

Tap-off outlet cover – IP 55



Trunking lengths – 1501 to 2999 mm with 2 + 2 outlets

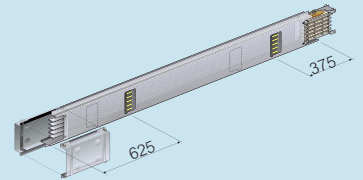

Trunking lengths – 1501 to 2999 mm without outlets

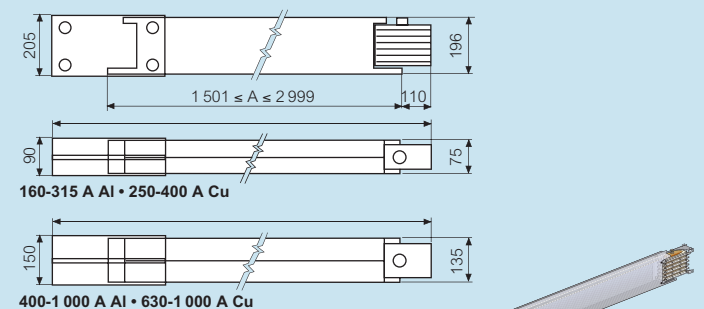

Trunking lengths – 1000 to 1500 mm with 1 + 1 outlets

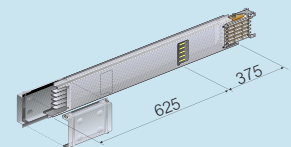

All dimensions (mm) are nominal

MR medium rating busbar

technical information (continued)

Trunking lengths – 600 to 1500 mm without outlets

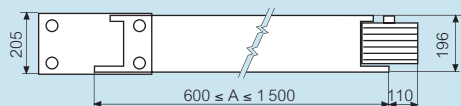

160-315 A Al • 250-400 A Cu



400-1 000 A Al • 630-1 000 A Cu

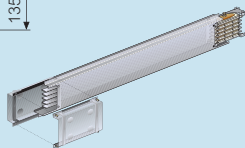

Trunking lengths with S120 fire barrier

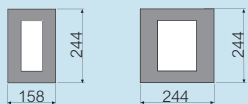

160-315 A Al
250-400 A Cu

400-1 000 A Al
630-1 000 A Cu

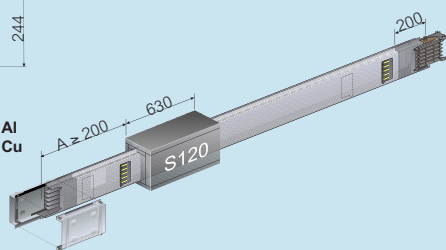

Single elbows – standard dimensions (300 + 300 mm)

90° as standard. Other angles available on request. IP 55 quick connection

Horizontal elbow

RH

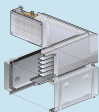

LH

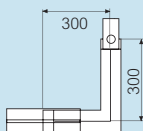
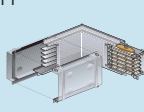

Vertical elbow

RH

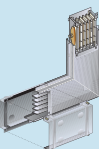

LH

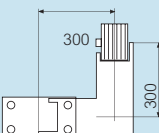
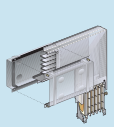

Bespoke dimensions

Measure from the long casing to the axis of the elbow (see measuring bespoke dimensions p. 49)

Special horizontal elbow

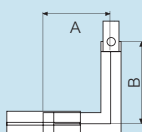

Bespoke dimensions (mm)

Min		Max
250 ≤	A	≤ 900
250 ≤	B	≤ 900

Special vertical elbow

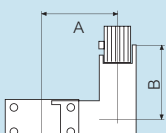

Bespoke dimensions (mm)

Min		Max
300 ≤	A	≤ 900
300 ≤	B	≤ 900

All dimensions (mm) are nominal

Double elbows

Standard dimensions (300 + 300 + 300 mm)

90° as standard. Other angles available on request. IP 55 quick connection

Bespoke dimensions

Measure from the long casing to the axis of the elbow

Double horizontal elbow

Right + left

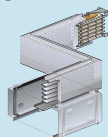

Left + right

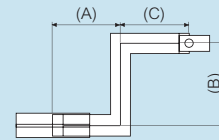
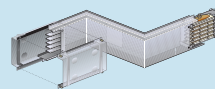

Bespoke dimensions (mm)

Min		Max
250 ≤	A, B, C	≤ 900

Double vertical elbow

Right + left

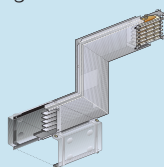

Left + right

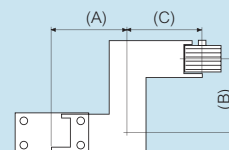
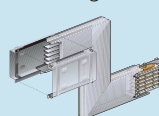

Bespoke dimensions (mm)

Min		Max
300 ≤	A, B, C	≤ 900

Vertical + horizontal elbows

RH + RH

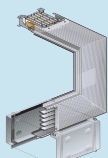

RH + LH

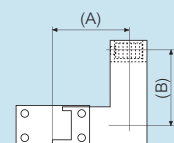
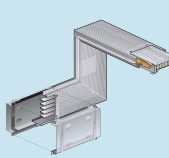

LH + RH

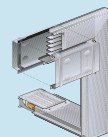

LH + LH

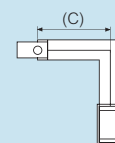
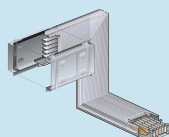

Bespoke dimensions (mm)

Min		Max
300 ≤	A, B, C	≤ 900

Horizontal + vertical elbows

RH + RH

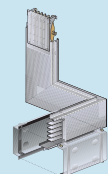

RH + LH

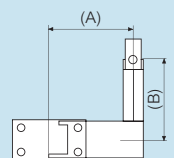
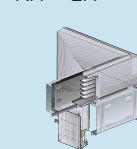

LH + RH

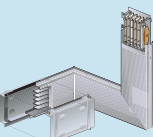

LH + LH

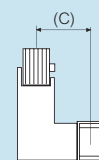
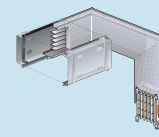

Bespoke dimensions (mm)

Min		Max
300 ≤	A, B, C	≤ 900

■ **Horizontal tee**

Standard dimensions (300 + 300 + 300 mm)

Right hand – female tee

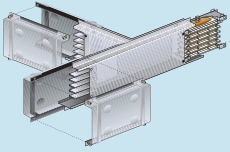

Right hand – male tee

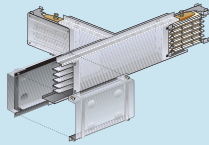

Left hand – female tee

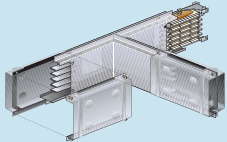

Left hand – male tee

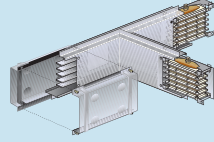

■ **Bespoke dimensions**

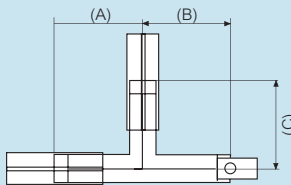

Bespoke dimensions (mm)		
Min		Max
250 ≤	A, B, C	≤ 900

■ **Crossover – standard dimensions (300 + 300 + 300 + 300 mm)**

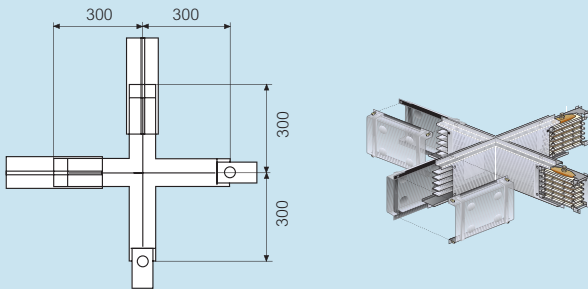

■ **End feed units**

Cable connection : max. sect. (3 x 120 mm² + 1 x 70 mm²) or 3 x 150 mm², max PG 48

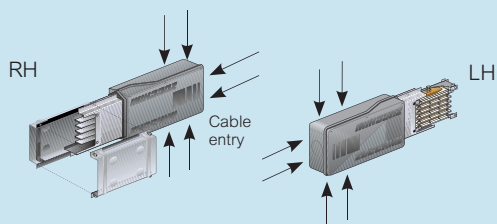
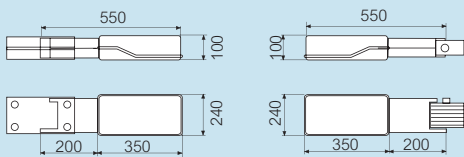

■ **Metal end feed units**

During shipment the stump is positioned in the box to reduce its bulk. Take it out and screw it in the position illustrated here. Opening on the base cable entry : 180 x 290 mm. For plates and holes dimensions, see p. 46 for the switchboard feed unit with the same rating

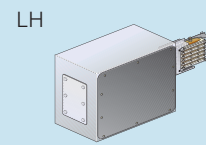
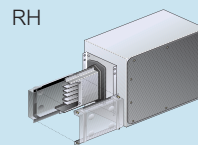
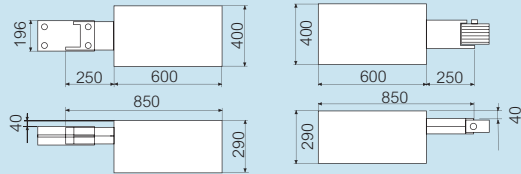

■ **End feed unit with AC23 switch disconnector**

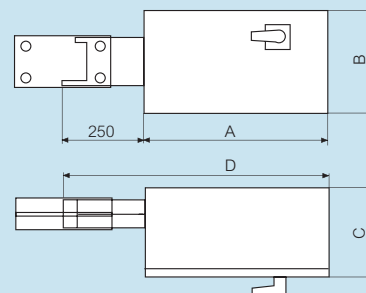

Dimensions (mm)		
	1	2
A	550	1050
B	350	450
C	280	300
D	800	1300

Cable entry dimensions (mm)		
	1	2
	180 x 270	210 x 380

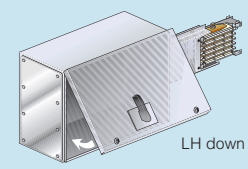
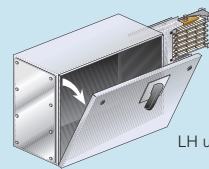
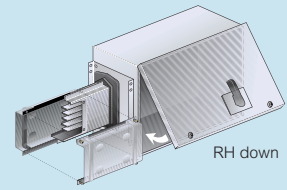
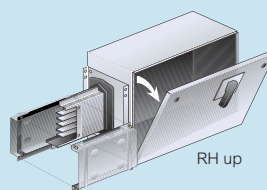

■ **Centre feed units**

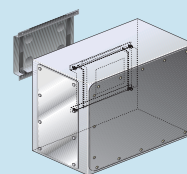
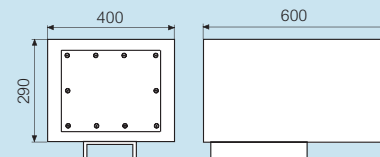

All dimensions (mm) are nominal

MR medium rating busbar

technical information (continued)

■ End stop

Ensures IP 55 protection at the end of the run (EN 60529)

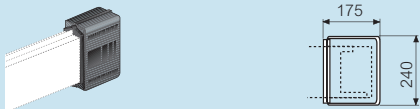

■ Switchboard-transformer feed units

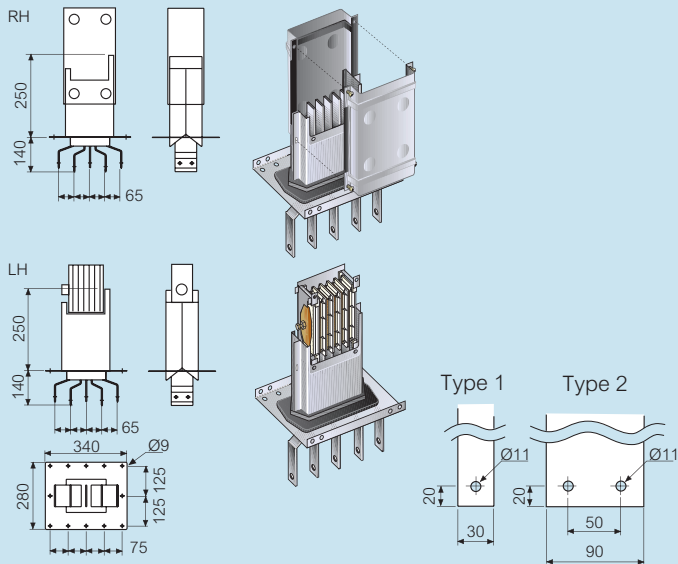

Dimensions (mm)		
	Al	Cu
Type 1	160 A	250 A
	250 A	315 A
	315 A	400 A
Type 2	400 A	630 A
	500 A	800 A
	630 A	1 000 A
	800 A	–
	1 000 A	–

■ In-line bus switch

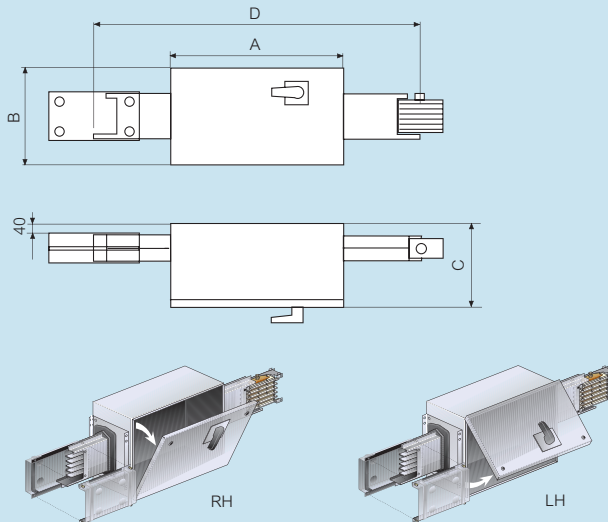

Dimensions (mm)		
Type 1		Type 2
550	A	1 050
350	B	450
280	C	300
1 050	D	1 550

All dimensions (mm) are nominal

■ Tap-off boxes

Type 1

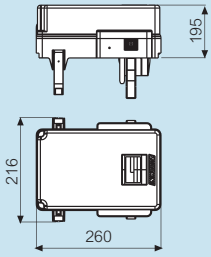

Type 2

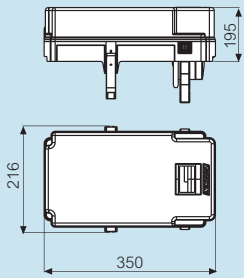

Type 3 32 A

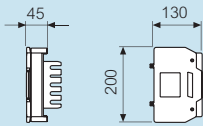

Type 4 63-160 A

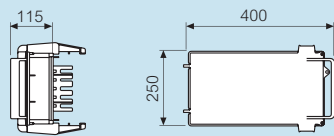

Type 5 250-400 A

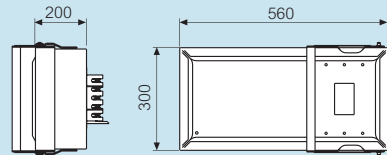

Type 6 63-160 A

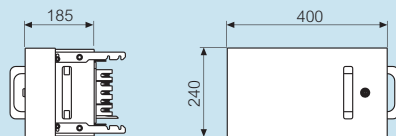

Type 7 250 A

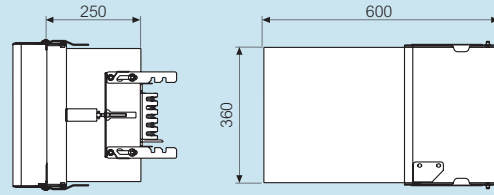

Type 8 400-630 A

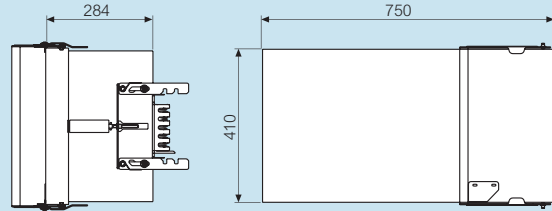

Type 9 630 A

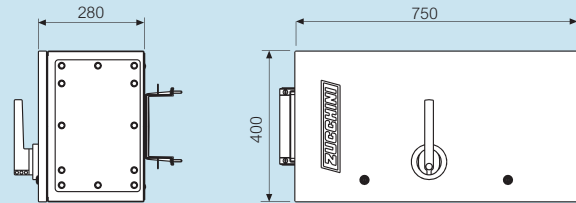

Type 10 800-1000 A

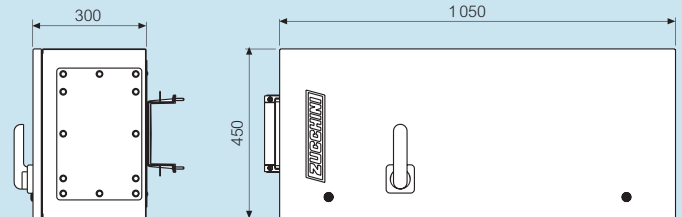

All dimensions (mm) are nominal

MR medium rating busbar

mounting tap-offs

■ Trunking length with 3 outlets

Edgeways

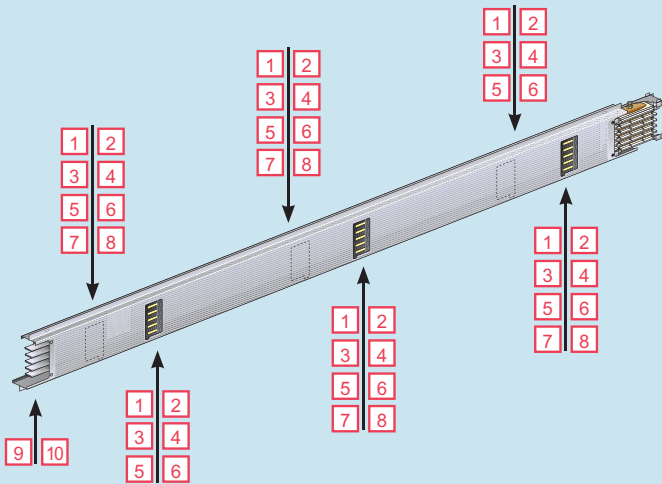

Numbers in squares refer to the tap-off box type

Rising main

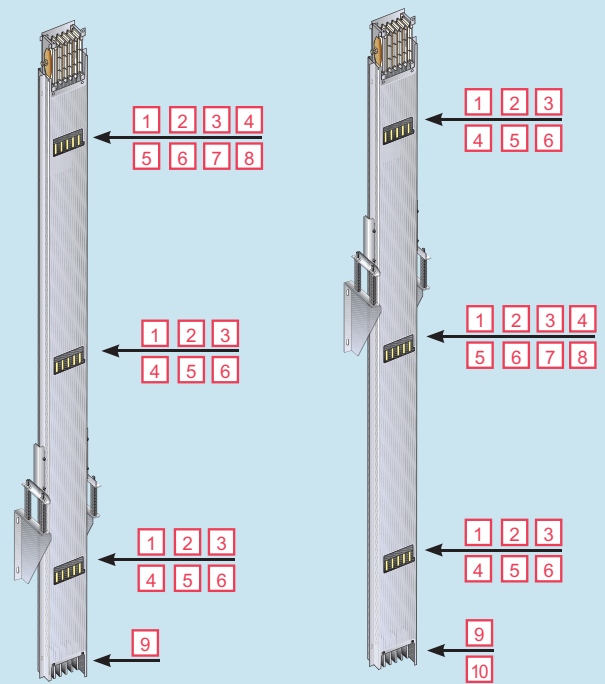

■ Trunking length with 5 outlets

Edgeways

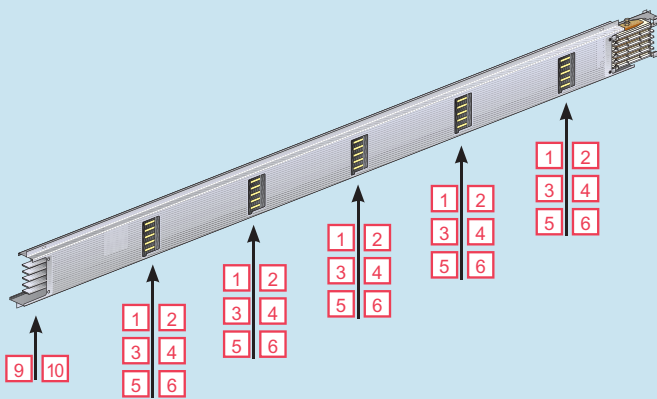

Numbers in squares refer to the tap-off box type

Rising main

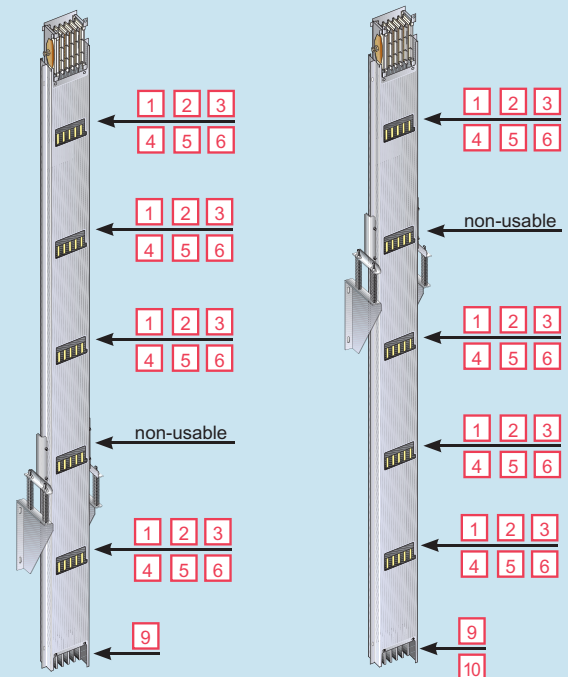

Note : in lengths with 5 outlets, using an outlet excludes the use of the next one

MR medium rating busbar

technical information

■ Suspension brackets

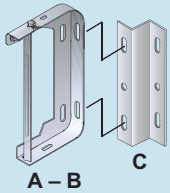
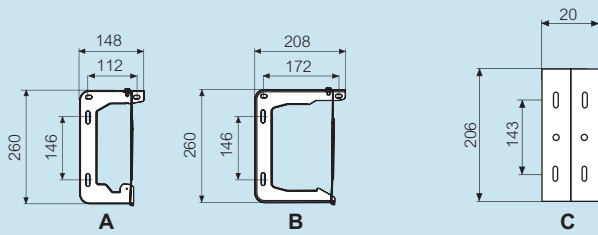

Cat. Nos.	
A	50632001
B	50632003
C	50632205

■ Wall fixing bracket

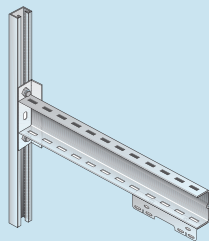
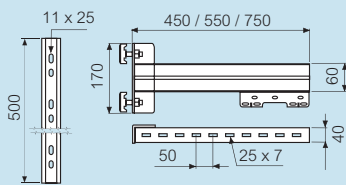

■ Ceiling fixing bracket kit

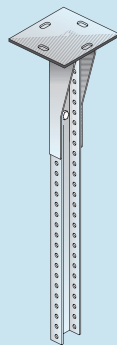
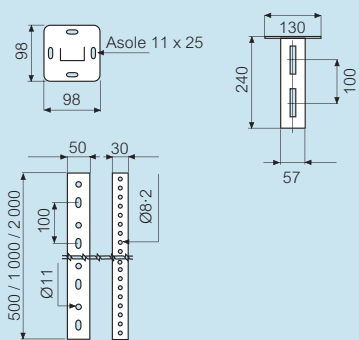

■ Beam fixing bracket

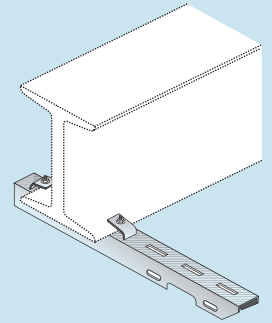
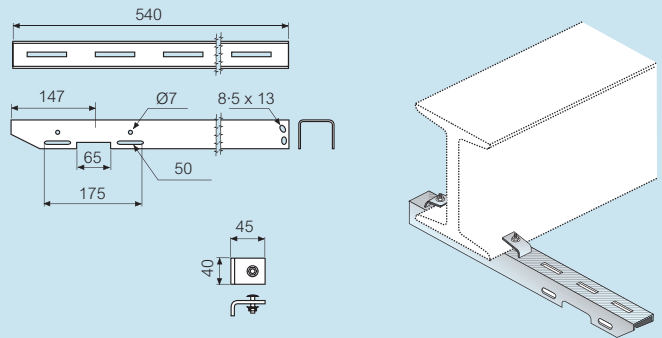

■ Triple cable channel

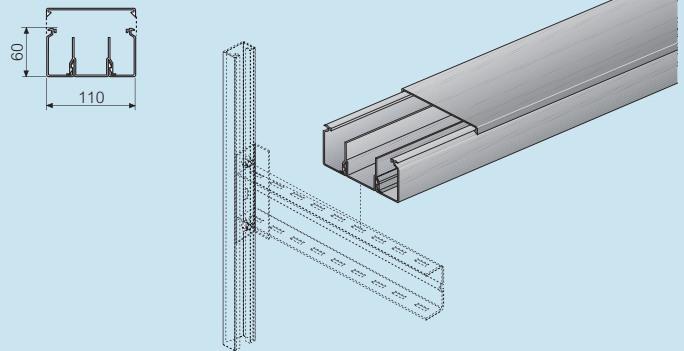

■ Measuring bespoke dimensions

Straight lengths

Always measure from the long side of the casing as illustrated

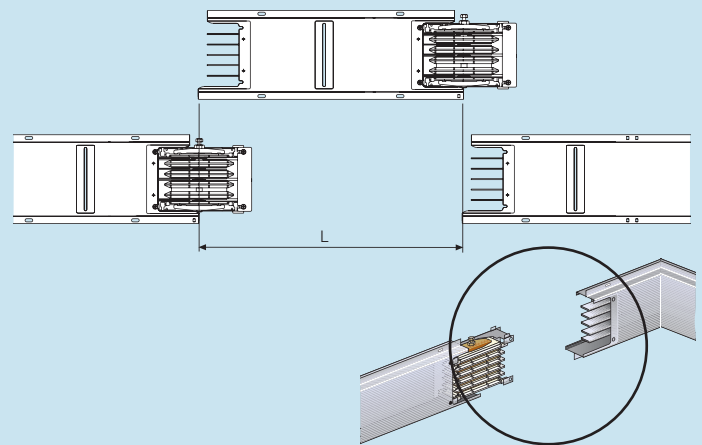

Elbows

Measure from the long casing to the axis of the elbow

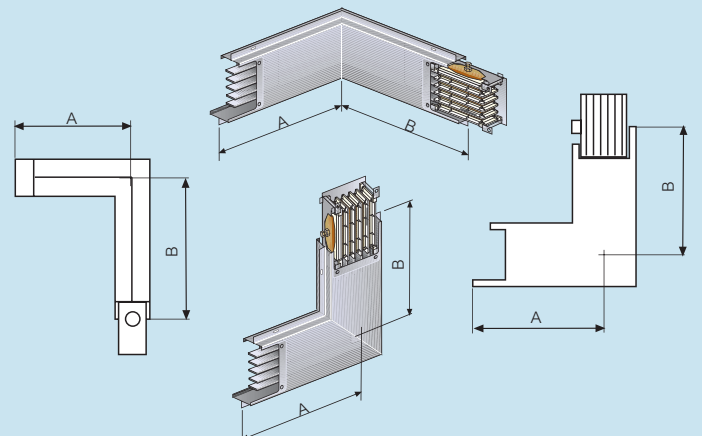

All dimensions (mm) are nominal

MR medium rating busbar

how to design the system

1 Use end feed unit LH – left hand

This gives the neutral bar positioning on the right of elements and the tap-off box with cable entry at the base

2 Use the vertical hanger for rising main as a function of the run weight

For vertical lengths less than 4 metres fit on the base of the busbar a vertical bracket (Cat. No. 50403711) for longer lengths use vertical suspension hanger (Cat. No. 50403712) every 300 kg of rising main

3 Use standard suspension brackets with spacer 40 mm every 2 m of the rising main

4 Use straight lengths with plug outlets on one side

5 Use the straight length with fire barrier to maintain the fire resistance of the floor

Please specify the position of the internal fire barrier before placing an order (see p. 140)

6 The tap-off box can be installed on the joint between the elements or on the outlets

7 At the end of the rising main use the end cover IP 55

Before mounting the end cover remove the monobloc prefitted on the last element of rising main

8 Maintain the plug outlet covers to guarantee the degree of protection IP 55 to the run

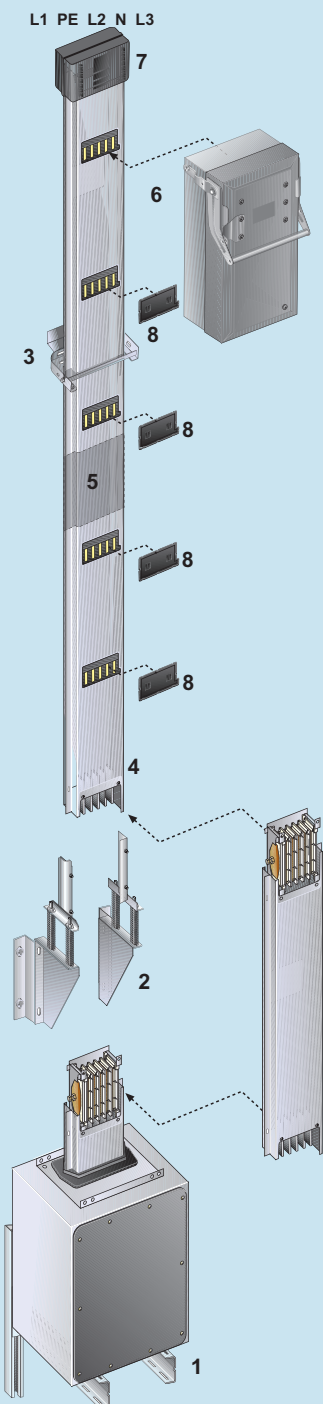

MR medium rating busbar

how to create codes for SB/MR adaptors

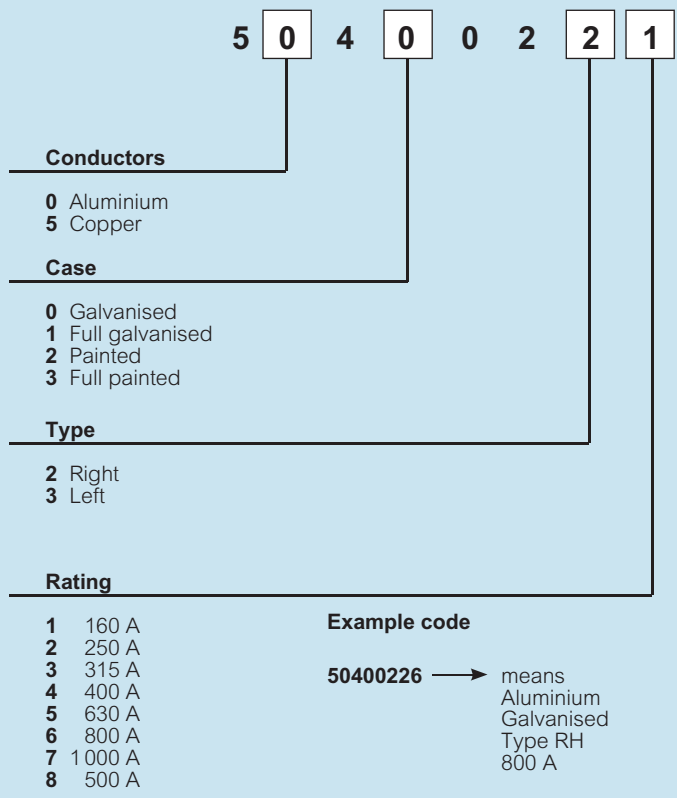
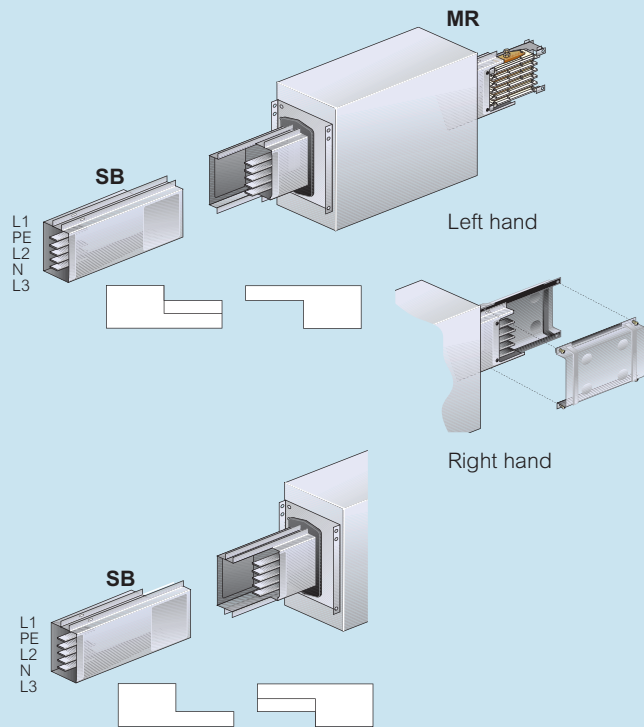
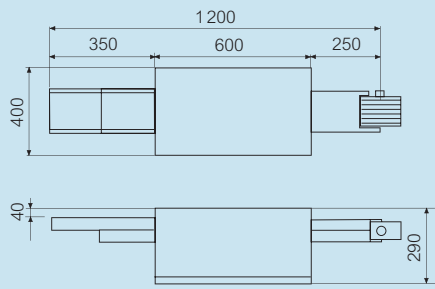

Example code

50400221 → means Aluminium Galvanised Type RH 800 A

55420235 → means Copper Full galvanised Type LH 630 A

NOTE
SB is a previous range of Zucchini medium rating busbar

MR medium rating busbar – 4 conductor (aluminium)

technical data

Complies to :
IEC 439-1 and 2, BS EN 60439 part 1 and 2,
DIN VDE 0660 part 500 and 502

Suitable for the following climates :
 Constant humid climate (DIN IEC 68 and 2 – 3)
 Cyclical humid climate (DIN IEC 68 and 2 – 30)

3L+N+PE (Aluminium)

	In (A)	160	250	315	400	500	630	800	1000
Rated current	I_n (A)	160	250	315	400	500	630	800	1000
Operational voltage	U_e (V)	1000	1000	1000	1000	1000	1000	1000	1000
Insulation voltage	U_i (V)	1000	1000	1000	1000	1000	1000	1000	1000
Frequency	f (Hz)	50/60	50/60	50/60	50/60	50/60	50/60	50/60	50/60
Rated shortcircuit current withstand for 3-phase fault (1 s)	I_{cw} (kA) _{rms}	15'	25'	25'	25	30	36	36	36
Specific Energy withstand for 3-phase fault	I^2t (M A ² s)	23	63	63	625	900	1296	1296	1296
Peak current	I_{pk} (kA)	30	53	53	53	63	76	76	76
Rated short-time current for single-phase fault Ph-N(1 s)	I_{cw} (kA) _{rms}	9'	15'	15'	15	18	22	22	22
Peak current for single-phase fault Ph-N	I_{pk} (kA)	15	30	30	30	36	45	45	45
Rated short-time current single-phase fault Ph-PE (1 s)	I_{cw} (kA) _{rms}	9'	15'	15'	15	18	22	22	22
Peak current single-phase fault Ph-PE	I_{pk} (kA)	15	30	30	30	36	45	45	45
Phase resistance at 20°C	R^{20} (mΩ/m)	0.492	0.328	0.197	0.120	0.077	0.060	0.052	0.039
Phase resistance at thermal conditions (I_n ; 40°C)	R_T (mΩ/m)	0.665	0.443	0.266	0.163	0.104	0.081	0.070	0.053
Phase reactance (50 Hz)	X (mΩ/m)	0.260	0.202	0.186	0.130	0.110	0.097	0.096	0.093
Neutral resistance at 20°C	R_{n20} (mΩ/m)	0.492	0.328	0.197	0.120	0.077	0.060	0.052	0.039
Neutral reactance (50 Hz)	X_n (mΩ/m)	0.260	0.202	0.186	0.130	0.110	0.097	0.096	0.093
Resistance of the protective bar	R_{PE} (mΩ/m)	0.341	0.341	0.341	0.283	0.283	0.283	0.283	0.283
Reactance of the protective bar (50 Hz)	X_{PE} (mΩ/m)	0.220	0.220	0.220	0.180	0.180	0.180	0.180	0.180
Resistance of the phase-Pe fault loop	R_{Ph-Pe} fault loop (mΩ/m)	1.006	0.784	0.607	0.445	0.387	0.364	0.353	0.336
Reactance of the phase-Pe fault loop (50 Hz)	$X_{R_{Ph-Pe}}$ fault loop (mΩ/m)	0.480	0.414	0.396	0.333	0.333	0.283	0.275	0.273
Resistance of the phase-neutral fault loop	R_{Ph-N} fault loop (mΩ/m)	1.157	0.771	0.463	0.283	0.181	0.141	0.121	0.093
Reactance of the phase-neutral fault loop (50 Hz)	$X_{R_{Ph-N}}$ fault loop (mΩ/m)	0.480	0.422	0.406	0.310	0.290	0.277	0.276	0.186
Voltage "k" drop coeff. with distributed load (k)	Δv (V/m/A) $10^{-6} \cos\varphi = 0.70$	564	394	276	179	131	109	102	90
	Δv (V/m/A) $10^{-6} \cos\varphi = 0.75$	581	404	279	180	130	108	100	88
	Δv (V/m/A) $10^{-6} \cos\varphi = 0.80$	596	412	281	180	129	107	98	85
	Δv (V/m/A) $10^{-6} \cos\varphi = 0.85$	608	418	281	179	127	104	95	82
	Δv (V/m/A) $10^{-6} \cos\varphi = 0.90$	616	422	277	176	122	100	91	77
	Δv (V/m/A) $10^{-6} \cos\varphi = 0.95$	617	419	269	169	115	93	83	69
	Δv (V/m/A) $10^{-6} \cos\varphi = 0.00$	576	384	230	141	90	70	60	46
Losses for the Joule effect at nominal current	P (W/m)	51	83	79	78	78	97	134	160
Fire load	(kWh/m)	1.3	1.3	1.3	1.8	1.8	1.8	1.8	1.8
Weight	ρ (kg/m)	7.4	7.7	8.4	10.7	12.3	13.8	14.7	15.9
Overall dimensions of the busbar	$L \times H$ (mm)	76 x 195	76 x 195	76 x 195	136 x 195	136 x 195	136 x 195	136 x 195	136 x 195
Degree of protection (CEI EN60529)	IP	52-55	52-55	52-55	52-55	52-55	52-55	52-55	52-55
IK code CEI EN60068-2-62	IK	10	10	10	10	10	10	10	10

1 : Values for 0.1 s

Temperature rating schedule

Mean room temperature (°C)	15	20	25	30	35	40	45	50	55	60
K1 factor	1.15	1.12	1.08	1.05	1.025	1	0.975	0.95	0.93	0.89

Multiplier coefficient of nominal rating for room temperature values different from 40°C

MR medium rating busbar – 4 conductor (copper)

technical data

Complies to :
IEC 439-1 and 2, BS EN 60439 part 1 and 2,
DIN VDE 0660 part 500 and 502

Suitable for the following climates :
Constant humid climate (DIN IEC 68 and 2 – 3)
Cyclical humid climate (DIN IEC 68 and 2 – 30)

3L+N+PE (Copper)

	In (A)	250	315	400	630	800	1000
Rated current	In (A)	250	315	400	630	800	1000
Operational voltage	Ue (V)	1000	1000	1000	1000	1000	1000
Insulation voltage	Ui (V)	1000	1000	1000	1000	1000	1000
Frequency	f (Hz)	50/60	50/60	50/60	50/60	50/60	50/60
Rated shortcircuit current withstand for 3-phase fault (1 s)	I _{cs} (kA) _{rms}	25 ¹	25 ¹	30 ¹	36	36	36
Specific Energy withstand for 3-phase fault	I ² t (M A ² s)	63	63	90	1296	1296	1296
Peak current	I _{pk} (kA)	53	53	63	76	76	76
Rated short-time current for single-phase fault Ph-N(1 s)	I _{cs} (kA) _{rms}	15 ¹	15 ¹	18 ¹	22	22	22
Peak current for single-phase fault Ph-N	I _{pk} (kA)	30	30	36	45	45	45
Rated short-time current single-phase fault Ph-PE (1 s)	I _{cs} (kA) _{rms}	15 ¹	15 ¹	18 ¹	22	22	22
Peak current single-phase fault Ph-PE	I _{pk} (kA)	30	30	36	45	45	45
Phase resistance at 20°C	R ²⁰ (mΩ/m)	0.237	0.180	0.096	0.061	0.040	0.032
Phase resistance at thermal conditions (I _n ; 40°C)	R _T (mΩ/m)	0.320	0.243	0.129	0.082	0.053	0.043
Phase reactance (50 Hz)	X (mΩ/m)	0.205	0.188	0.129	0.122	0.122	0.120
Neutral resistance at 20°C	R _{N20} (mΩ/m)	0.237	0.180	0.096	0.061	0.040	0.032
Neutral reactance (50 Hz)	X _n (mΩ/m)	0.205	0.188	0.129	0.122	0.122	0.120
Resistance of the protective bar	R _{PE} (mΩ/m)	0.336	0.336	0.336	0.279	0.279	0.279
Reactance of the protective bar (50 Hz)	X _{PE} (mΩ/m)	0.220	0.220	0.220	0.180	0.180	0.180
Resistance of the phase-Pe fault loop	R _{Ph-Pe fault loop} (mΩ/m)	0.657	0.579	0.466	0.361	0.332	0.322
Reactance of the phase-Pe fault loop (50 Hz)	X _{RPh-Pe fault loop} (mΩ/m)	0.425	0.408	0.349	0.302	0.302	0.300
Resistance of the phase-neutral fault loop	R _{Ph-N fault loop} (mΩ/m)	0.558	0.423	0.225	0.143	0.093	0.074
Reactance of the phase-neutral fault loop (50 Hz)	X _{RPh-N fault loop} (mΩ/m)	0.425	0.408	0.349	0.302	0.302	0.300
Voltage "k" drop coeff. with distributed load (k)	$\Delta v (V/m/A)10^{-6} \cos\varphi = 0.70$	321	263	158	125	108	100
	$\Delta v (V/m/A)10^{-6} \cos\varphi = 0.75$	326	265	158	123	105	96
	$\Delta v (V/m/A)10^{-6} \cos\varphi = 0.80$	329	266	157	120	100	92
	$\Delta v (V/m/A)10^{-6} \cos\varphi = 0.85$	329	264	154	116	95	86
	$\Delta v (V/m/A)10^{-6} \cos\varphi = 0.90$	327	260	149	110	88	79
	$\Delta v (V/m/A)10^{-6} \cos\varphi = 0.95$	319	251	141	101	77	68
	$\Delta v (V/m/A)10^{-6} \cos\varphi = 0.00$	277	210	112	71	46	37
Losses for the Joule effect at nominal current	P (W/m)	60	72	62	98	103	128
Fire load	(kWh/m)	1.3	1.3	1.3	1.8	1.8	1.8
Weight	p (kg/m)	9.3	10.2	13.3	18.2	23.9	27.9
Overall dimensions of the busbar	L x H (mm)	76 x 195	76 x 195	76 x 195	136 x 195	136 x 195	136 x 195
Degree of protection (CEI EN60529)	IP	52-55	52-55	52-55	52-55	52-55	52-55
IK code CEI EN60068-2-62	IK	10	10	10	10	10	10

1 : Values for 0.1 s

Temperature rating schedule

Mean room temperature (°C)	15	20	25	30	35	40	45	50	55	60
K1 factor	1.15	1.12	1.08	1.05	1.025	1	0.975	0.95	0.93	0.89

Multiplier coefficient of nominal rating for room temperature values different from 40°C

MR medium rating busbar – five conductor (aluminium)

technical data

Complies to :
IEC 439-1 and 2, BS EN 60439 part 1 and 2,
DIN VDE 0660 part 500 and 502

Suitable for the following climates :
 Constant humid climate (DIN IEC 68 and 2 – 3)
 Cyclical humid climate (DIN IEC 68 and 2 – 30)

3L+N 100% +PE 100% (Aluminium)

	In (A)	160	250	315	400	500	630	800	1000
Rated current	I_n (A)	160	250	315	400	500	630	800	1000
Operational voltage	U_e (V)	1000	1000	1000	1000	1000	1000	1000	1000
Insulation voltage	U_i (V)	1000	1000	1000	1000	1000	1000	1000	1000
Frequency	f (Hz)	50/60	50/60	50/60	50/60	50/60	50/60	50/60	50/60
Rated shortcircuit current withstand for 3-phase fault (1 s)	I_{cw} (kA) _{rms}	15 ¹	25 ¹	25 ¹	25	30	36	36	36
Specific Energy withstand for 3-phase fault	I^2t (M A ² s)	23	63	63	625	900	1296	1296	1296
Peak current	I_{pk} (kA)	30	53	53	53	63	76	76	76
Rated short-time current for single-phase fault Ph-N(1 s)	I_{cw} (kA) _{rms}	9 ¹	15 ¹	15 ¹	15	18	22	22	22
Peak current for single-phase fault Ph-N	I_{pk} (kA)	15	30	30	30	36	45	45	45
Rated short-time current single-phase fault Ph-PE (1 s)	I_{cw} (kA) _{rms}	9 ¹	15 ¹	15 ¹	15	18	22	22	22
Peak current single-phase fault Ph-PE	I_{pk} (kA)	15	30	30	30	36	45	45	45
Phase resistance at 20°C	R^{20} (mΩ/m)	0.492	0.328	0.197	0.120	0.077	0.060	0.052	0.039
Phase resistance at thermal conditions (I_n ; 40°C)	R_T (mΩ/m)	0.665	0.443	0.266	0.163	0.104	0.081	0.070	0.053
Phase reactance (50 Hz)	X (mΩ/m)	0.260	0.202	0.186	0.130	0.110	0.097	0.096	0.093
Neutral resistance at 20°C	R_{n20} (mΩ/m)	0.492	0.328	0.197	0.120	0.077	0.060	0.052	0.039
Neutral reactance (50 Hz)	X_n (mΩ/m)	0.260	0.202	0.186	0.130	0.110	0.097	0.096	0.093
Resistance of the protective bar	R_{PE} (mΩ/m)	0.202	0.167	0.125	0.084	0.060	0.050	0.044	0.034
Reactance of the protective bar (50 Hz)	X_{PE} (mΩ/m)	0.119	0.105	0.101	0.075	0.068	0.063	0.063	0.061
Resistance of the phase-Pe fault loop	R_{Ph-Pe} fault loop (mΩ/m)	0.866	0.611	0.391	0.247	0.164	0.131	0.113	0.087
Reactance of the phase-Pe fault loop (50 Hz)	$X_{R_{Ph-Pe}}$ fault loop (mΩ/m)	0.379	0.307	0.287	0.205	0.178	0.160	0.159	0.154
Resistance of the phase-neutral fault loop	R_{Ph-N} fault loop (mΩ/m)	1.157	0.771	0.463	0.283	0.181	0.141	0.121	0.093
Reactance of the phase-neutral fault loop (50 Hz)	$X_{R_{Ph-N}}$ fault loop (mΩ/m)	0.520	0.404	0.372	0.260	0.220	0.194	0.192	0.186
Voltage "k" drop coeff. with distributed load (k)	Δv (V/m/A) $10^{-6} \cos\varphi = 0.70$	564	394	276	179	131	109	102	90
	Δv (V/m/A) $10^{-6} \cos\varphi = 0.75$	581	404	279	180	130	108	100	88
	Δv (V/m/A) $10^{-6} \cos\varphi = 0.80$	596	412	281	180	129	107	98	85
	Δv (V/m/A) $10^{-6} \cos\varphi = 0.85$	608	418	281	179	127	104	95	82
	Δv (V/m/A) $10^{-6} \cos\varphi = 0.90$	616	422	277	176	122	100	91	77
	Δv (V/m/A) $10^{-6} \cos\varphi = 0.95$	617	419	269	169	115	93	83	69
	Δv (V/m/A) $10^{-6} \cos\varphi = 0.00$	576	384	230	141	90	70	60	46
Losses for the Joule effect at nominal current	P (W/m)	51	83	79	78	78	97	134	160
Fire load	(kWh/m)	1.3	1.3	1.3	1.8	1.8	1.8	1.8	1.8
Weight	ρ (kg/m)	7.6	8.0	8.9	11.4	13.5	15.2	16.4	17.9
Overall dimensions of the busbar	$L \times H$ (mm)	76 x 195	76 x 195	76 x 195	136 x 195	136 x 195	136 x 195	136 x 195	136 x 195
Degree of protection (CEI EN60529)	IP	52-55	52-55	52-55	52-55	52-55	52-55	52-55	52-55
IK code CEI EN60068-2-62	IK	10	10	10	10	10	10	10	10

1 : Values for 0.1 s

Temperature rating schedule

Mean room temperature (°C)	15	20	25	30	35	40	45	50	55	60
K1 factor	1.15	1.12	1.08	1.05	1.025	1	0.975	0.95	0.93	0.89

Multiplier coefficient of nominal rating for room temperature values different from 40°C

MR medium rating busbar – five conductor (copper)

technical data

Complies to :
IEC 439-1 and 2, BS EN 60439 part 1 and 2,
DIN VDE 0660 part 500 and 502

Suitable for the following climates :
Constant humid climate (DIN IEC 68 and 2 – 3)
Cyclical humid climate (DIN IEC 68 and 2 – 30)

3L+N 100% +PE 100% (Copper)

	In (A)	250	315	400	630	800	1000
Rated current	In (A)	250	315	400	630	800	1000
Operational voltage	Ue (V)	1000	1000	1000	1000	1000	1000
Insulation voltage	Ui (V)	1000	1000	1000	1000	1000	1000
Frequency	f (Hz)	50/60	50/60	50/60	50/60	50/60	50/60
Rated shortcircuit current withstand for 3-phase fault (1 s)	I _{cs} (kA) _{rms}	25'	25'	30'	36	36	36
Specific Energy withstand for 3-phase fault	I ² t (M A ² s)	63	63	90	1296	1296	1296
Peak current	I _{pk} (kA)	53	53	63	76	76	76
Rated short-time current for single-phase fault Ph-N(1 s)	I _{cs} (kA) _{rms}	15'	15'	18'	22	22	22
Peak current for single-phase fault Ph-N	I _{pk} (kA)	30	30	36	45	45	45
Rated short-time current single-phase fault Ph-PE (1 s)	I _{cs} (kA) _{rms}	15'	15'	18'	22	22	22
Peak current single-phase fault Ph-PE	I _{pk} (kA)	30	30	36	45	45	45
Phase resistance at 20°C	R ²⁰ (mΩ/m)	0.237	0.180	0.096	0.061	0.040	0.032
Phase resistance at thermal conditions (I _n ; 40°C)	R _t (mΩ/m)	0.320	0.243	0.129	0.082	0.053	0.043
Phase reactance (50 Hz)	X (mΩ/m)	0.205	0.188	0.129	0.122	0.122	0.120
Neutral resistance at 20°C	R _{N20} (mΩ/m)	0.237	0.180	0.096	0.061	0.040	0.032
Neutral reactance (50 Hz)	X _n (mΩ/m)	0.205	0.188	0.129	0.122	0.122	0.120
Resistance of the protective bar	R _{PE} (mΩ/m)	0.139	0.117	0.075	0.050	0.035	0.028
Reactance of the protective bar (50 Hz)	X _{PE} (mΩ/m)	0.106	0.101	0.081	0.073	0.073	0.072
Resistance of the phase-Pe fault loop	R _{Ph-Pe fault loop} (mΩ/m)	0.460	0.360	0.204	0.132	0.088	0.071
Reactance of the phase-Pe fault loop (50 Hz)	X _{RPh-Pe fault loop} (mΩ/m)	0.311	0.289	0.210	0.195	0.195	0.192
Resistance of the phase-neutral fault loop	R _{Ph-N fault loop} (mΩ/m)	0.558	0.423	0.225	0.143	0.093	0.074
Reactance of the phase-neutral fault loop (50 Hz)	X _{RPh-N fault loop} (mΩ/m)	0.311	0.289	0.210	0.195	0.195	0.192
Voltage "k" drop coeff. with distributed load (k)	$\Delta v (V/m/A)10^{-6} \cos\varphi = 0.70$	321	263	158	125	108	100
	$\Delta v (V/m/A)10^{-6} \cos\varphi = 0.75$	326	265	158	123	105	96
	$\Delta v (V/m/A)10^{-6} \cos\varphi = 0.80$	329	266	157	120	100	92
	$\Delta v (V/m/A)10^{-6} \cos\varphi = 0.85$	329	264	154	116	95	86
	$\Delta v (V/m/A)10^{-6} \cos\varphi = 0.90$	327	260	149	110	88	79
	$\Delta v (V/m/A)10^{-6} \cos\varphi = 0.95$	319	251	141	101	77	68
	$\Delta v (V/m/A)10^{-6} \cos\varphi = 0.00$	277	210	112	71	46	37
Losses for the Joule effect at nominal current	P (W/m)	60	72	62	98	103	128
Fire load	(kWh/m)	1.3	1.3	1.3	1.8	1.8	1.8
Weight	p (kg/m)	10.0	11.1	14.9	20.8	27.9	32.9
Overall dimensions of the busbar	L x H (mm)	76 x 195	76 x 195	76 x 195	136 x 195	136 x 195	136 x 195
Degree of protection (CEI EN60529)	IP	52-55	52-55	52-55	52-55	52-55	52-55
IK code CEI EN60068-2-62	IK	10	10	10	10	10	10

1 : Values for 0.1 s

Temperature rating schedule

Mean room temperature (°C)	15	20	25	30	35	40	45	50	55	60
K1 factor	1.15	1.12	1.08	1.05	1.025	1	0.975	0.95	0.93	0.89

Multiplier coefficient of nominal rating for room temperature values different from 40°C

MR medium rating busbar

determining the operating current of a busbar

In order to determine the correct busbar rating, the current must be established using the following criteria :

- type of load inputs – three phase or single-phase
- type of circuit input – from one end, from both ends, central input, etc.
- nominal input voltage
- number, power and $\cos\varphi$ of loads which are to be fed by the busbar
- load diversity factor
- load use nominal factor
- assumed short circuit current at the input point
- room temperature
- type of busbar installation (edgeways, flat or vertical)

When using a three phase power supply, the operating current is determined by the following formula :

$$I_b = \frac{P_{TOT} \cdot \alpha \cdot \beta \cdot d}{\sqrt{3} \cdot U_e \cdot \cos\varphi_{medium}} \text{ (A)}$$

Where :

I_b	operating current (A)
α	load diversity factor (.)
β	load use factor (.)
d	feed factor (.)
P_{TOT}	sum of the total active power of installed loads (W)
U_e	operating voltage (V)
$\cos\varphi_{medium}$	average load power factor (.)

The 'd' input factor has a value of 1 when the busbar is fed from one end only. The value is $1/2$ if fed from the centre or if it is fed from each end

Once the operating current has been determined, choose the busbar with a rated current immediately higher than the one calculated

All Zucchini products have been designed and tested for an average room temperature of 40°C; should they be installed in rooms with average daily temperatures different from 40°C, the rated current of the busbar should be multiplied by a k_1 factor that is greater than the unit for temperatures lower than 40°C, and lower than the unit if the room temperature is higher than 40°C

Room temperature (°C)	15	20	25	30	35	40	45	50	55	60
k_1 , thermal correction factor (.)	1.15	1.12	1.08	1.05	1.025	1	0.975	0.95	0.93	0.89

Finally, the following should be considered for the most appropriate busbar choice :

$$I_{nt} \geq I_b \Leftrightarrow I_{nt} = k_1 \cdot I_n$$

where I_{nt} represents the maximum current loaded by a busbar for an indefinite time at the specified room temperature

Voltage drop

If the length of the line is particularly long (>100m) it is necessary to check the voltage drop (hereinafter specified as v.d.). If the installation is a three phase system and the power factor is not lower than $\cos\varphi = 0.7$ the v.d. may be calculated with the coefficients of the voltage drop specified in the technical data table.

$$\Delta v\% = b \cdot \frac{k \cdot I_b \cdot L}{V_n} \cdot 100$$

Defined :

I_b	= the current that supplies the busbar (A)
V_n	= the voltage power supply of the busbar (V)
L	= the length of the busbar (m)
$\Delta v\%$	= the voltage drop percentage
b	= the distribution factor of the current (.)
k	= corresponding voltage drop factor a $\cos\varphi$ (V/m/A) (see technical data table, p. 52-55)

The current distribution factor "b" depends on how the circuit is fed and on the distribution of the electric loads along the busbar :

b = 2	Supplies at one end and load at the end of the line	
b = 1	Supplies at one end and with load evenly distributed	
b = 0.5	Supplies at both ends and with load evenly distributed	
b = 0.5	Central supply with loads at both ends	
b = 0.25	Central supply with load distributed evenly	

Example : MR 400 A Al for riser mains feed

I_b	= 315 A operating current
b = 1	= supply from one end
k = 179	= see technical data table, p. 52-55
$\cos\varphi$	= 0.85
L	= 30 m line length
V_n	= 400 V operating voltage
$\Delta v\% = 1 \times \frac{179 \cdot 10^{-6} \cdot 315 \cdot 30}{400} \times 100 = 0.42\%$	

Short circuit current

The short circuit current value I_{sc} that can be supported by Zucchini busbar trunking systems allows for both electrodynamic stress and thermal energy dissipated during the fault

The busbars must be able to sustain the short circuit current for the entire duration of the fault – i.e. for the time required for the protective device (circuit breaker) to start operating, cutting off the metal continuity and extinguishing the electric arc

Joule effect losses

Losses due to the Joule effect are essentially caused by the electrical resistance of the busbar. Lost energy is transformed into heat and contributes to the heating of the conduit

Three phase rating

$$P = 3 \cdot R_t \cdot I_b^2 \cdot 10^{-3} \text{ (W/m)}$$

Single phase rating

$$P = 2 \cdot R_t \cdot I_b^2 \cdot 10^{-3} \text{ (W/m)}$$

ZUCCHINI TS - TROLLEY SYSTEM BUSBAR

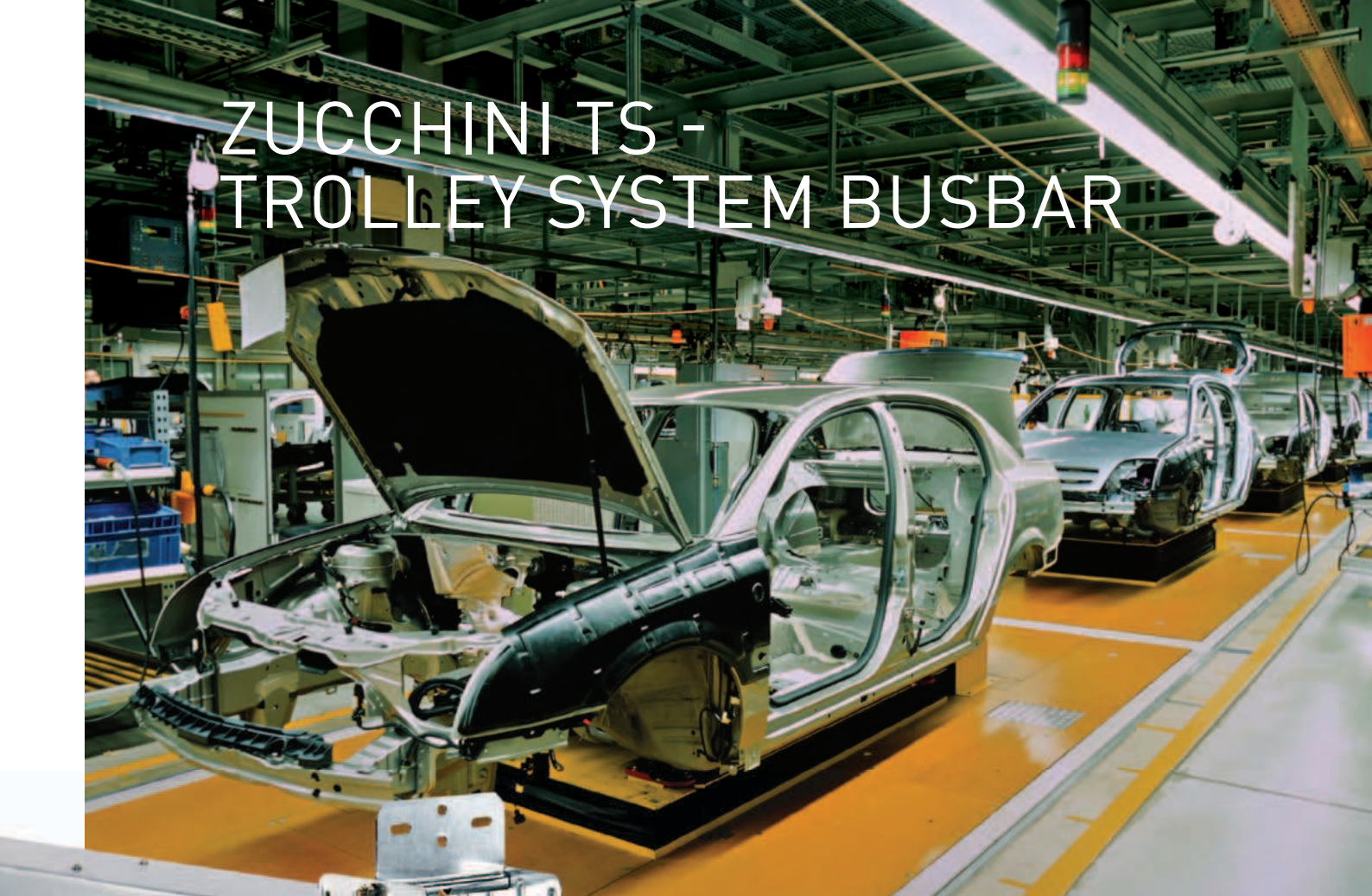

The Zucchini TS busbar range is ideal for supplying 25 to 160 A three phase loads to moving devices such as overhead cranes, traversing motors, assembly lines, etc.

Suitable for straight and curved sections with horizontal route changes, TS busbar is quick and easy to install using an electrical terminal junction and a wide range of supporting accessories.

Versions include :

- 3L+N+PE (5 conductors)
- 3L+PE (4 conductors)



To find out more call our technical support team on
+44 (0) 845 600 6266