

ZUCCHINI LB PLUS - LIGHTING AND POWER BUSBAR

Zucchini LB PLUS is a new range of 25 to 63 A busbars that are ideal for the distribution of power for lighting and low power applications. With a single product, LB PLUS replaces the LB, HL, and SL ranges, offering a busbar that is simpler, better performing, and easier to install.



A winning solution delivering performance and simplicity... with increased functionality, fewer part numbers and common accessories for all versions



SHOPPING CENTRES,
STORES, OFFICES



WAREHOUSES,
GYMS, UNDERGROUND
CAR PARKS



HOSPITALS,
LABORATORIES

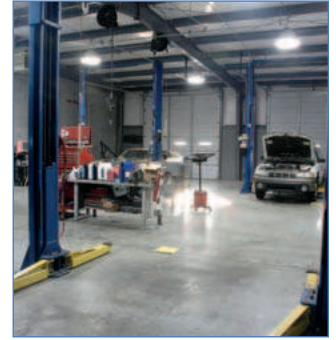

WORKSHOPS,
MAINTENANCE AND
REPAIR FACILITIES,
PRODUCTION SITES

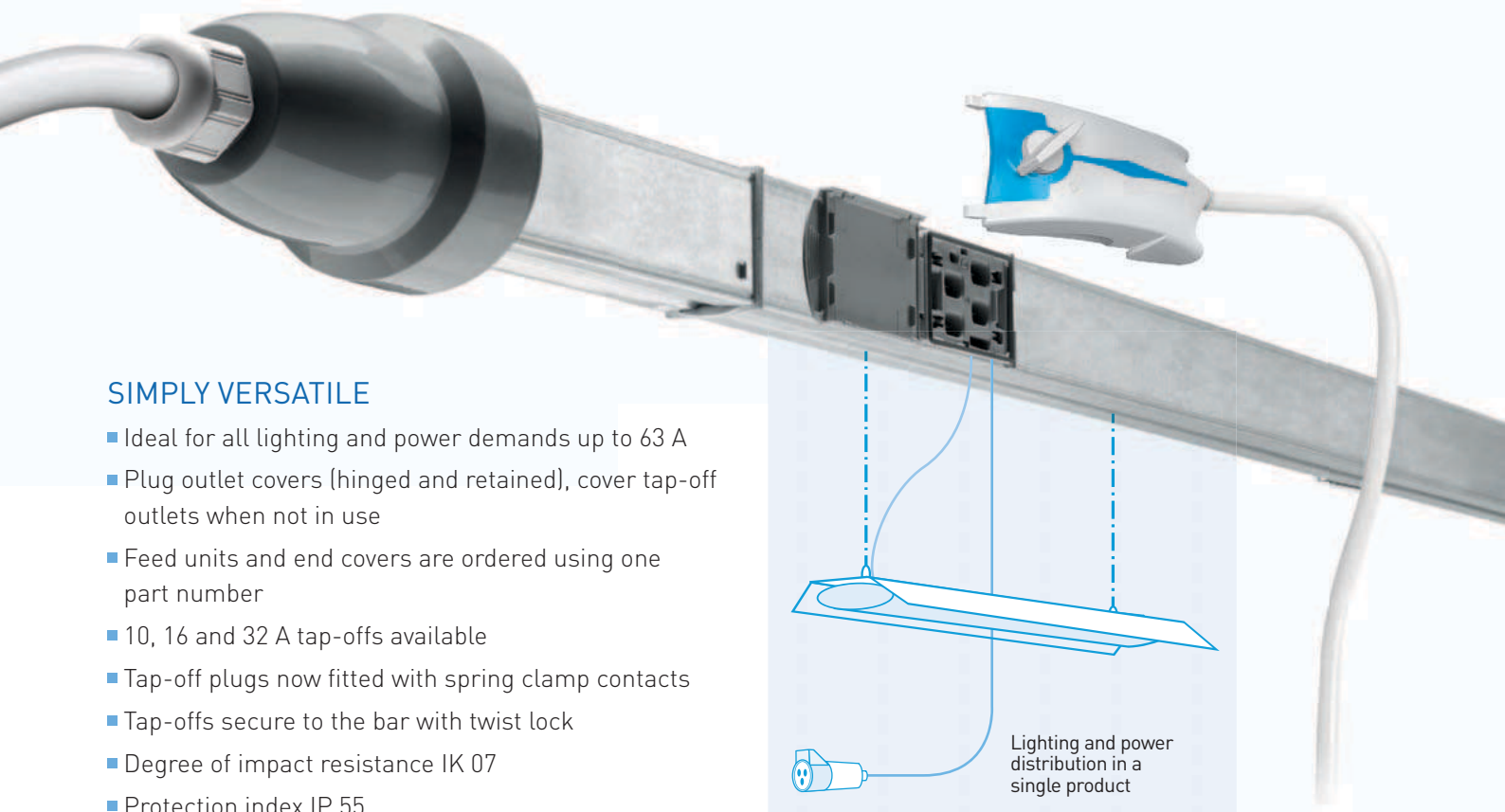

SIMPLY VERSATILE

- Ideal for all lighting and power demands up to 63 A
- Plug outlet covers (hinged and retained), cover tap-off outlets when not in use
- Feed units and end covers are ordered using one part number
- 10, 16 and 32 A tap-offs available
- Tap-off plugs now fitted with spring clamp contacts
- Tap-offs secure to the bar with twist lock
- Degree of impact resistance IK 07
- Protection index IP 55

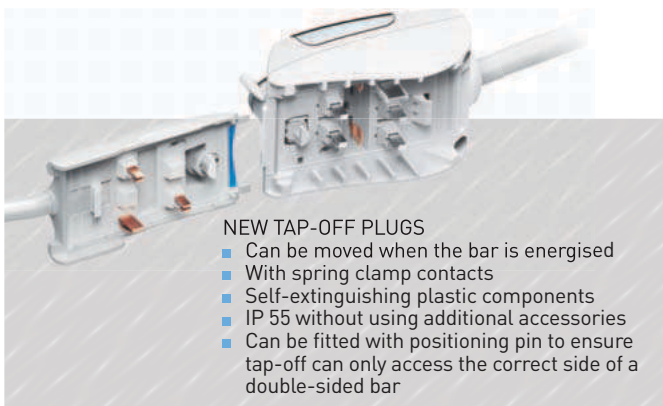

NEW TAP-OFF PLUGS

- Can be moved when the bar is energised
- With spring clamp contacts
- Self-extinguishing plastic components
- IP 55 without using additional accessories
- Can be fitted with positioning pin to ensure tap-off can only access the correct side of a double-sided bar



BRACKETS

- For ceiling, wall or floor mounting installation
- Can be positioned anywhere on straight length, even over unused tap-off outlets

LB PLUS busbar trunking systems

selection chart

	25 A				40 A		63 A
	2 conductors	4 conductors	6 conductors	8 conductors	4 conductors	8 conductors	4 conductors
LB PLUS STRAIGHT LENGTHS – TYPE A	252	254	256	258	404	408	634
3 m length – 2 outlets	75150101	75160101	–	–	75200101	–	–
3 m length – 4 outlets	–	75160102	–	–	75200102	–	–
3 m length – 2 + 2 outlets	–	–	75170101	75180101	–	75220101	75240101
3 m length – 4 + 4 outlets	–	–	–	75180102	–	75220102	75240102
1.5 m length – 2 outlets	75200111		–	–	75220111	–	–
1.5 m length – 1 + 1 outlets	–	–	75220111		75200111	75220111	75240111
LB PLUS STRAIGHT LENGTHS – TYPE B	252	254	256	258	404	408	634
3 m length – 4 outlets	75350102H	75360102H	–	–	75400102H	–	–
3 m length – 6 outlets	–	75360103H	–	–	75400103H	–	–
3 m length – 4 + 4 outlets	–	–	75370101H	75380101H	–	75420101H	75440101H
3 m length – 6 + 6 outlets	–	–	–	75380102H	–	75420102H	75440102H
1.5 m length – 2 outlets	75400111H		–	–	75400111H	–	–
1.5 m length – 1 + 1 outlets	–	–	75420111H		–	75420111H	75440111H
FEED UNITS	252	254	256	258	404	408	634
RH feed unit + end cover	75201001		75221001		75201001	75221001	75241001
LH feed unit + end cover	75201002		75221002		75201002	75221002	75241002
Fast fit – feed unit	75161001		–	–	–	–	–
Centre feed unit + end covers	75201151		75221151		75201151	75221151	75241151
FLEXIBLE JOINT	75201261		75221261		75201261	75221261	75241261
BRACKETS AND SUSPENSIONS	252	254	256	258	404	408	634
60 kg suspension bracket	75003000 (for TYPE A)			and	75003004 for (TYPE B)		
Hook for lamp	75003001						
Ring	75003002						
Pigtail for chain	75003005						
5 m steel cable with self locking clamp (TYPE B)	75003008 (TYPE B only)						
Bracket with 3 m steel cable (TYPE A)	75003009 (TYPE A only)						
CABLE CHANNEL	252	254	256	258	404	408	634
PVC cable channel with cover (3 m)	75000104						
Bracket for cable channel	75003006						

10 A SINGLE PHASE TAP-OFFS	252	254	256	258	404	408	634
10 A plug with 1 m cable - L1-N	75005011						
10 A plug with 1 m cable - L2-N	–	75005012					
10 A plug with 1 m cable - L3-N	–	75005013					
10 A plug with 1 m cable - L-N2	–	75005014					
10 A plug with 3 m cable - L1-N	75005021						
10 A plug with 3 m cable - L2-N	–	75005022					
10 A plug with 3 m cable - L3-N	–	75005023					
10 A plug with 3 m cable - L-N2	–	75005024					
16 A PHASE SELECTION TAP-OFFS	252	254	256	258	404	408	634
16 A plug (unfused)	75005000						
16 A plug + 1 x (5 x 20)	–	75005100					
16 A plug + 1 x (CH8)	–	75005200					
16 A PRE-WIRED TAP-OFFS	252	254	256	258	404	408	634
SP & N with 1.5 m cable and 6.3 A fuse - L1-N	750051001L1						
SP & N with 1.5 m cable and 6.3 A fuse - L2-N	–	750051001L2					
SP & N with 1.5 m cable and 6.3 A fuse - L3-N	–	750051001L3					
SP & N with 1.5 m cable and 6.3 A fuse - L-N2	–	750051001N2					
DP & N with 1.5 m cable and 1 x 6.3 A fuse - L1+L3-N	–	7500510014C					
SP & N with 3 m cable and 6.3 A fuse - L1-N	750051003L1						
SP & N with 3 m cable and 6.3 A fuse - L2-N	–	750051003L2					
SP & N with 3 m cable and 6.3 A fuse - L3-N	–	750051003L3					
SP & N with 3 m cable and 6.3 A fuse - L-N2	–	750051003N2					
DP & N with 3 m cable and 1 x 6.3 A fuse - L1+L3-N	–	7500510034C					
THREE-PHASE TAP-OFFS – 16 - 32A	252	254	256	258	404	408	634
16 A 3 phase (unfused)	–	75005005					
32 A 3 phase (unfused)	–	75006005					
32 A 3 phase + 3 x (CH10)	–	75006205					
TAP-OFF ACCESSORIES	252	254	256	258	404	408	634
16 A mobile contact	75105000						
Window kit code	75105001						

LB PLUS straight lengths – Type A

straight lengths 25-63 A

LB PLUS straight lengths – Type B

straight lengths 25-63 A



75160102

75360102H

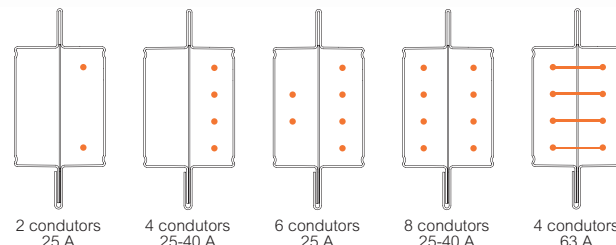
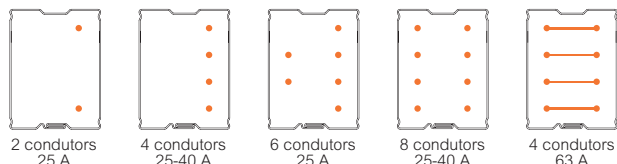

Selection chart p. 6-7
 Technical data p. 12
 Dimensions and technical information p. 14-15



Selection chart p. 6-7
 Technical data p. 13
 Dimensions and technical information p. 14-15

Pack	Cat. Nos.	Straight lengths – Type A				
		Rigid galvanised steel casing 3 m maximum distance between suspension brackets Conductors insulated with self-extinguishing plastic (IEC 60695-2-12 and V0 according to UL94) Standard tap-off outlets with captive IP 55 plug-outlet covers Protection index IP 55 Impact resistance : IK 07				
		252 with 2 x 25 A conductors				
1	75150101	Rating (A)	Conductors	Length (m)	Outlet points	Weight (kg)
		25	2	3-0	2	3-00
		254 with 4 x 25 A conductors				
1	75160101	Rating (A)	Conductors	Length (m)	Outlet points	Weight (kg)
		25	4	3-0	2	3-10
1	75160102	Rating (A)	Conductors	Length (m)	Outlet points	Weight (kg)
		25	4	3-0	4	3-20
		256 with 6 x 25 A conductors				
1	75170101	Rating (A)	Conductors	Length (m)	Outlet points	Weight (kg)
		25	6	3-0	2 + 2	3-65
		258 with 8 x 25 A conductors				
1	75180101	Rating (A)	Conductors	Length (m)	Outlet points	Weight (kg)
		25	8	3-0	2 + 2	3-75
1	75180102	Rating (A)	Conductors	Length (m)	Outlet points	Weight (kg)
		25	8	3-0	4 + 4	3-85
		404 with 4 x 40 A conductors				
1	75200101	Rating (A)	Conductors	Length (m)	Outlet points	Weight (kg)
		40	4	3-0	2	3-55
1	75200102	Rating (A)	Conductors	Length (m)	Outlet points	Weight (kg)
		40	4	3-0	4	3-65
1	75200111 ¹	Rating (A)	Conductors	Length (m)	Outlet points	Weight (kg)
		40	4	1-5	2	2-00
		408 with 8 x 40 A conductors				
1	75220101	Rating (A)	Conductors	Length (m)	Outlet points	Weight (kg)
		40	8	3-0	2 + 2	4-70
1	75220102	Rating (A)	Conductors	Length (m)	Outlet points	Weight (kg)
		40	8	3-0	4 + 4	4-80
1	75220111 ²	Rating (A)	Conductors	Length (m)	Outlet points	Weight (kg)
		40	8	1-5	1 + 1	2-50
		634 with 4 x 63 A conductors				
1	75240101	Rating (A)	Conductors	Length (m)	Outlet points	Weight (kg)
		63	4	3-0	2 + 2	4-70
1	75240102	Rating (A)	Conductors	Length (m)	Outlet points	Weight (kg)
		63	4	3-0	4 + 4	4-80
1	75240111	Rating (A)	Conductors	Length (m)	Outlet points	Weight (kg)
		63	4	1-5	1 + 1	2-50

1 : For use with both 25 and 40 A systems, and also 2 and 4 conductor versions
 2 : For use with both 25 and 40 A systems, and also 6 and 8 conductor versions

Pack	Cat. Nos.	Straight lengths – Type B				
		Reinforced highly rigid galvanised steel casing 7 m maximum distance between suspension brackets Conductors insulated with self-extinguishing plastic ZH (zero halogen) Standard tap-off outlets with captive IP 55 plug-outlet covers Mechanical separation of the 2 sides of the bar, (6 and 8 conductors versions) Protection index IP 55 Impact resistance : IK 07				
		252 with 2 x 25 A conductors				
1	75350102H	Rating (A)	Conductors	Length (m)	Outlet points	Weight (kg)
		25	2	3-0	4	5-45
		254 with 4 x 25 A conductors				
1	75360102H	Rating (A)	Conductors	Length (m)	Outlet points	Weight (kg)
		25	4	3-0	4	5-55
1	75360103H	Rating (A)	Conductors	Length (m)	Outlet points	Weight (kg)
		25	4	3-0	6	5-60
		256 with 6 x 25 A conductors				
1	75370101H	Rating (A)	Conductors	Length (m)	Outlet points	Weight (kg)
		25	6	3-0	4 + 4	6-10
		258 with 8 x 25 A conductors				
1	75380101H	Rating (A)	Conductors	Length (m)	Outlet points	Weight (kg)
		25	8	3-0	4 + 4	6-20
1	75380102H	Rating (A)	Conductors	Length (m)	Outlet points	Weight (kg)
		25	8	3-0	6 + 6	6-35
		404 with 4 x 40 A conductors				
1	75400102H	Rating (A)	Conductors	Length (m)	Outlet points	Weight (kg)
		40	4	3-0	4	6-00
1	75400103H	Rating (A)	Conductors	Length (m)	Outlet points	Weight (kg)
		40	4	3-0	6	6-10
1	75400111H ¹	Rating (A)	Conductors	Length (m)	Outlet points	Weight (kg)
		40	4	1-5	2	3-20
		408 with 8 x 40 A conductors				
1	75420101H	Rating (A)	Conductors	Length (m)	Outlet points	Weight (kg)
		40	8	3-0	4 + 4	7-10
1	75420102H	Rating (A)	Conductors	Length (m)	Outlet points	Weight (kg)
		40	8	3-0	6 + 6	7-30
1	75420111H ²	Rating (A)	Conductors	Length (m)	Outlet points	Weight (kg)
		40	8	1-5	1 + 1	3-70
		634 with 4 x 63 A conductors				
1	75440101H	Rating (A)	Conductors	Length (m)	Outlet points	Weight (kg)
		63	4	3-0	4 + 4	7-10
1	75440102H	Rating (A)	Conductors	Length (m)	Outlet points	Weight (kg)
		63	4	3-0	6 + 6	7-30
1	75440111H	Rating (A)	Conductors	Length (m)	Outlet points	Weight (kg)
		63	4	1-5	1 + 1	3-70

1 : For use with both 25 and 40 A systems, and also 2 and 4 conductor versions
 2 : For use with both 25 and 40 A systems, and also 6 and 8 conductor versions

LB PLUS trunking components



75201001



75161001



75201002



75221261



Selection chart **p. 6-7**
 Technical data **p. 12-13**
 Dimensions and technical information **p. 16-17**

Pack	Cat. Nos.	End feed units	
		Allow electrical powering of the LB PLUS busbar With terminals for the connection of stranded or solid copper wire cables Delivered with corresponding cable glands	
		Right hand feed units	
		Supplied complete with corresponding end cover Cable terminal capacity 6 mm ² to 25 mm ² Max. cable Ø 32 mm	
		Type	Weight (kg)
1	75201001	25 / 40 A – 2 / 4 conductors version	0·85
1	75221001	25 / 40 A – 6 / 8 conductors version	0·90
1	75241001	63 A – 4 conductors version	0·90
		Left hand feed units	
		Supplied complete with corresponding end cover Cable terminal capacity 6 mm ² to 25 mm ² Max. cable Ø 32 mm	
		Type	Weight (kg)
1	75201002	25 / 40 A – 2 / 4 conductors version	1·20
1	75221002	25 / 40 A – 6 / 8 conductors version	1·20
1	75241002	63 A – 4 conductor version	1·20
		Fast fit feed unit	
		Supplied complete with corresponding end cover Cable terminal capacity up to 6 mm ² Cable Ø from 12 mm to 18 mm	
		Type	Weight (kg)
1	75161001	25 A – 2 / 4 conductors version	0·45

Pack	Cat. Nos.	Centre feed units	
		Centre feed units can be used to power the busbar from an intermediate point of the line, reducing the voltage drop at the end of the line and/or facilitating the installation when the power supply point is near the centre of the line Complete with all internal wiring One set of terminals feeds both left hand and right hand feed sections Supplied with both end caps	
		Type	Weight (kg)
1	75201151	25 / 40 A – 2 / 4 conductors version	4·00
1	75221151	25 / 40 A – 6 / 8 conductors version	4·15
1	75241151	63 A – 4 conductors version	4·25
		Flexible joints	
		Consists of a right hand and left hand unit Used to change direction, change level or overcome obstructions Flexible cable length : 940 mm	
		Type	Weight (kg)
1	75201261	25 / 40 A – 2 / 4 conductors version	2·25
1	75221261	25 / 40 A – 6 / 8 conductors version	2·35
1	75241261	63 A – 4 conductors version	2·45

LB PLUS tap-off plugs

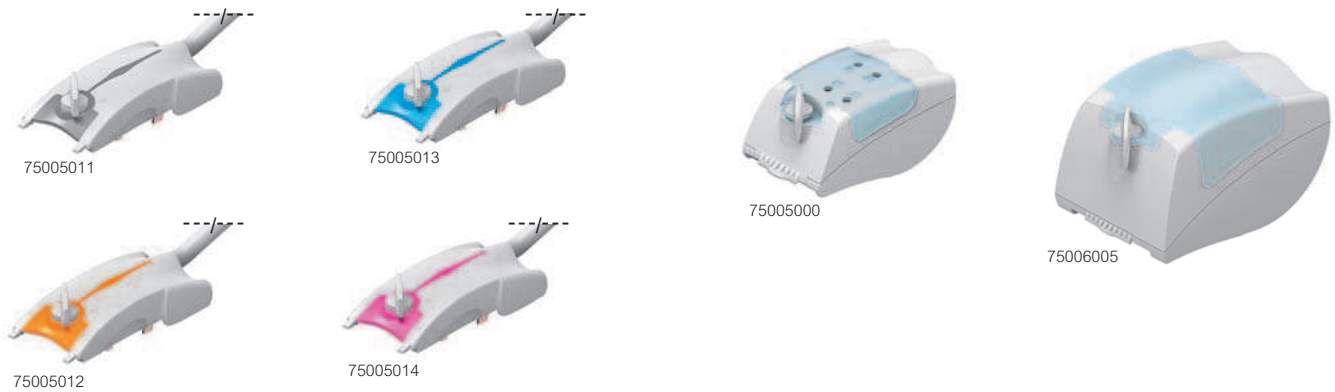

Selection chart **p. 6-7**
 Technical data **p. 12-13**
 Dimensions and technical information **p. 16-17**

Pack	Cat. Nos.	10 A single phase tap-offs												
1	75005011	For use with Type A and Type B busbar, all ratings L1 colour code grey, cable type H05WF <table border="1"> <thead> <tr> <th>Phase</th> <th>Length (m)</th> <th>Weight (kg)</th> <th>Fuseholder</th> </tr> </thead> <tbody> <tr> <td>L1-N</td> <td>1</td> <td>0.16</td> <td>unfused</td> </tr> <tr> <td>L1-N</td> <td>3</td> <td>0.38</td> <td>unfused</td> </tr> </tbody> </table>	Phase	Length (m)	Weight (kg)	Fuseholder	L1-N	1	0.16	unfused	L1-N	3	0.38	unfused
Phase	Length (m)		Weight (kg)	Fuseholder										
L1-N	1	0.16	unfused											
L1-N	3	0.38	unfused											
1	75005021													
1	75005012	L2 colour code orange, cable type H05WF <table border="1"> <thead> <tr> <th>Phase</th> <th>Length (m)</th> <th>Weight (kg)</th> <th>Fuseholder</th> </tr> </thead> <tbody> <tr> <td>L2-N</td> <td>1</td> <td>0.16</td> <td>unfused</td> </tr> <tr> <td>L2-N</td> <td>3</td> <td>0.38</td> <td>unfused</td> </tr> </tbody> </table>	Phase	Length (m)	Weight (kg)	Fuseholder	L2-N	1	0.16	unfused	L2-N	3	0.38	unfused
Phase	Length (m)		Weight (kg)	Fuseholder										
L2-N	1	0.16	unfused											
L2-N	3	0.38	unfused											
1	75005022													
1	75005013	L3 colour code blue, cable type H05WF <table border="1"> <thead> <tr> <th>Phase</th> <th>Length (m)</th> <th>Weight (kg)</th> <th>Fuseholder</th> </tr> </thead> <tbody> <tr> <td>L3-N</td> <td>1</td> <td>0.16</td> <td>unfused</td> </tr> <tr> <td>L3-N</td> <td>3</td> <td>0.38</td> <td>unfused</td> </tr> </tbody> </table>	Phase	Length (m)	Weight (kg)	Fuseholder	L3-N	1	0.16	unfused	L3-N	3	0.38	unfused
Phase	Length (m)		Weight (kg)	Fuseholder										
L3-N	1	0.16	unfused											
L3-N	3	0.38	unfused											
1	75005023													
1	75005014	L-N2 colour code magenta, cable type H05WF <table border="1"> <thead> <tr> <th>Phase</th> <th>Length (m)</th> <th>Weight (kg)</th> <th>Fuseholder</th> </tr> </thead> <tbody> <tr> <td>L-N2</td> <td>1</td> <td>0.16</td> <td>unfused</td> </tr> <tr> <td>L-N2</td> <td>3</td> <td>0.38</td> <td>unfused</td> </tr> </tbody> </table>	Phase	Length (m)	Weight (kg)	Fuseholder	L-N2	1	0.16	unfused	L-N2	3	0.38	unfused
Phase	Length (m)		Weight (kg)	Fuseholder										
L-N2	1	0.16	unfused											
L-N2	3	0.38	unfused											
1	75005024													

Pack	Cat. Nos.	16 A phase selection tap-offs	Weight (kg)
1	75005000	16 A plug (unfused)	0.12
1	75005100	16 A plug + 1 x (5x20)	0.13
1	75005200	16 A plug + 1 x (CH8)	0.13

Pack	Cat. Nos.	16 A pre-wired tap-offs	Phase	
1	750051001L1	For use with Type A and Type B busbar, all ratings With 1.5 m cable SP & N with 6.3 A fuse SP & N with 6.3 A fuse SP & N with 6.3 A fuse SP & N with 6.3 A fuse DP & N with 1 x 6.3 A fuse	L1-N	
1	750051001L2		L2-N	
1	750051001L3		L3-N	
1	750051001LN2		L-N2	
1	7500510014C		L1+L3-N	
1	750051003L1	With 3 m cable SP & N with 6.3 A fuse SP & N with 6.3 A fuse SP & N with 6.3 A fuse SP & N with 6.3 A fuse DP & N with 1 x 6.3 A fuse	L1-N	
1	750051003L2		L2-N	
1	750051003L3		L3-N	
1	750051003LN2		L-N2	
1	7500510034C		L1+L3-N	
1	75005005	3 phase tap-offs – 16-32 A For use with Type A and Type B busbar, all ratings	Weight (kg)	
1	75006005		16 A 3 phase (unfused)	0.13
1	75006205		32 A 3 phase (unfused) 32 A 3 phase + 3 x (CH10)	0.42 0.43

Pack	Cat. Nos.	Tap-off accessories
10	75105000	Used with Cat. Nos. 75005000 or 75005100 to make contact with additional conductors on the busbar 16 A mobile contact
20	75105001	Enables tap-off to access a single designated side of the busbar Window kit code

LB PLUS busbar trunking system

hangers and cable channel



75003000



75003004



71000104



75003006



75003002

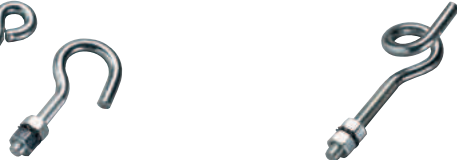

75003001



75003005

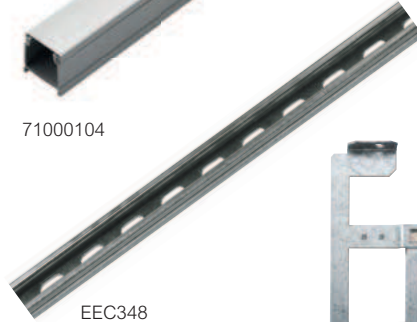

EEC348



EEA313



EEC353



Dimensions and technical information p. 18-19

Pack	Cat. Nos.	Hangers
12 12	75003000 75003004	60 kg suspension bracket Bracket Cat. No. 75003000 can be used for the suspension of the line and the suspension of light fittings at the same time, while bracket Cat. No. 75003004 may only perform one of the two functions, depending on its rotation For Type A busbar – weight 0.045 kg For Type B busbar – weight 0.045 kg
10	75003001	Hook for lamp Must always be used with brackets Cat. Nos. 75003000 or 75003004, depending on the type of busbar Weight 0.015 kg
10	75003002	Ring Must always be used with brackets Cat. Nos. 75003000 or 75003004, depending on the type of busbar Weight 0.015 kg
10	75003005	Pigtail for chain Must always be used with brackets Cat. Nos. 75003000 or 75003004, depending on the type of busbar Weight 0.015 kg
12	75003008	5 m steel cable with self locking clamp For Type B busbar – weight 0.085 kg
12	75003009	Bracket with 3 m steel cable For Type A busbar – weight 0.05 kg

Pack	Cat. Nos.	Brackets
1	597013	Must always be used with brackets Cat. Nos. 75003000 or 75003004, depending on the type of busbar Bracket for wall mounting
1	557300	Bracket for floor or ceiling mounting

Pack	Cat. Nos.	PVC cable channel
1	71000104	PVC cable channel with cover 3 m – weight 0.884 kg
6	75003006	Bracket for cable channel Must always be used with brackets Cat. Nos. 75003000 or 75003004 depending on the type of busbar and cable channel Cat. No. 71000104 Weight 0.135 kg
1	EEC348	Steel cable tray Cable tray 3 m (L) x 50 mm (W) x 13 mm (H)
1	EEA313	Trunking suspended fixing bracket c/w cable tray stirrup. Used when running cable tray on top of busbar trunking
1	EEC353	Cable tray fixing bracket

LB PLUS busbar trunking systems

technical data

■ LB PLUS - Type A

Type		252	254	256	258	404	408	634	
Number of live conductors		2	4	6	8	4	8	4	
Casing overall dimensions	LxH [mm]	35 x 46	35 x 46	35 x 46	35 x 46	35 x 46	35 x 46	35 x 46	
Rated current	In [A]	25	25	25	25	40	40	63	
Section of protective conductor ⁽¹⁾	S _{PE} [mm ²]	91.45	91.45	91.45	91.45	91.45	91.45	91.45	
Section of protective conductor ⁽¹⁾ eq.Cu	S _{PE} (=Cu) [mm ²]	11	11	11	11	11	11	11	
Operating voltage	Ue [V]	400	400	400	400	400	400	400	
Insulation voltage	Ui [V]	690	690	690	690	690	690	690	
Frequency	f [Hz]	5/6	5/6	5/6	5/6	5/6	5/6	5/6	
Rated short-time current (0.1 s)	I _{CW} [kArms]	2.2	2.2	2.2	2.2	2.7	2.7	2.7	
Allowable peak current	I _{pk} [kA]	4.4	4.4	4.4	4.4	5.4	5.4	5.4	
Thermal limit	I ² t [A ² s x 10 ⁶]	0.484	0.484	0.484	0.484	0.729	0.729	0.729	
20° C phase resistance	R ₂₀ [mΩ/m]	5.278	5.278	5.278	5.278	5.278	2.891	2.891	
Phase resistance at thermal conditions	R _t [mΩ/m]	6.798	6.798	6.798	6.798	3.793	3.793	3.399	
Phase reactance (50Hz)	X [mΩ/m]	1.114	1.279	1.279	1.114	1.279	0.770	0.637	
Phase impedance	Z [mΩ/m]	5.394	5.431	5.431	5.394	5.431	2.992	2.715	
Resistance of the protective conductor ¹	R _{PE} [mΩ/m]	0.203	0.203	0.203	0.203	0.203	0.203	0.203	
Reactance of the protective conductor (50Hz)	X _{PE} [mΩ/m]	1.100	1.100	1.000	1.000	1.100	1.000	1.000	
Resistance of the fault loop	R _o [mΩ/m]	5.482	5.482	5.482	5.482	3.094	3.094	2.843	
Reactance of the fault loop (50Hz)	X _o [mΩ/m]	2.214	2.379	2.279	2.279	1.870	1.770	1.637	
Impedance of the fault loop	Z _o [mΩ/m]	5.912	5.976	5.936	5.936	3.615	3.565	3.280	
Voltage drop with distributed load	ΔV 10 ⁻³ cosφ = 0.70 [V/m/A]	4.81	3.99	3.99	3.89	3.99	2.23	2.23	1.99
	ΔV 10 ⁻³ cosφ = 0.75 [V/m/A]	5.05	4.16	4.16	4.07	4.16	2.32	2.32	2.08
	ΔV 10 ⁻³ cosφ = 0.80 [V/m/A]	5.29	4.32	4.32	4.24	4.32	2.40	2.40	2.16
	ΔV 10 ⁻³ cosφ = 0.85 [V/m/A]	5.51	4.47	4.47	4.39	4.47	2.48	2.48	2.23
	ΔV 10 ⁻³ cosφ = 0.90 [V/m/A]	5.72	4.60	4.60	4.53	4.60	2.54	2.54	2.30
	ΔV 10 ⁻³ cosφ = 0.95 [V/m/A]	5.89	4.69	4.69	4.64	4.69	2.59	2.59	2.34
	ΔV 10 ⁻³ cosφ = 1.00 [V/m/A]	5.89	4.57	4.57	4.57	4.57	2.50	2.50	2.29
Weight	p [kg/m]	1.00	1.04	1.25	1.28	1.19	1.56	1.56	
Fire load	[kWh/m]	1.03	1.03	1.91	1.91	1.0	1.9	1.9	
Protection index	IP	55	55	55	55	55	55	55	
Degree of impact-resistance	IK	7	7	7	7	7	7	7	
Joule effect losses at rated current	P [W/m]	12.7	12.7	12.7	12.7	18.2	18.2	40.5	
Ambient temperature min / MAX	t [°C]	-5/+50	-5/+50	-5/+50	-5/+50	-5/+50	-5/+50	-5/+50	

1 : metal casing

$$\Delta V1F = \frac{\sqrt{1}}{2} (2 R_{20} \cos\varphi + 2 X \sin\varphi)$$

$$\Delta V3F = \frac{\sqrt{3}}{2} (R_{20} \cos\varphi + X \sin\varphi)$$

Short circuit protection for Zucchini's product ranges (I_n ≤ 100A)

Zucchini busbar trunking systems with a rated current lower than or equal to 100A (LB PLUS-MS 63 and 100) are properly protected through an MCB (Modular Circuit Breaker) with a rated current lower than or equal to that of the busbar. This protection is guaranteed up to the MCB breaking capacity

Product fully in compliance with IEC EN 60439-2

LB PLUS busbar trunking systems

technical data

■ LB PLUS – Type B

Type		252	254	256	258	404	408	634	
Number of live conductors		2	4	6	8	4	8	4	
Casing overall dimensions	LxH [mm]	35 x 77	35 x 77	35 x 77	35 x 77	35 x 77	35 x 77	35 x 77	
Rated current	I _n [A]	25	25	25	25	40	40	63	
Section of protective conductor ⁽¹⁾	S _{PE} [mm ²]	195	195	195	195	195	195	195	
Section of protective conductor ⁽¹⁾ eq·Cu	S _{PE} (=Cu) [mm ²]	24	24	24	24	24	24	24	
Operating voltage	U _e [V]	400	400	400	400	400	400	400	
Insulation voltage	U _i [V]	690	690	690	690	690	690	690	
Frequency	f [Hz]	5/6	5/6	5/6	5/6	5/6	5/6	5/6	
Rated short-time current (0·1 s)	I _{cw} [kArms]	2·5	2·5	2·5	2·5	3·2	3·2	3·2	
Allowable peak current	I _{pk} [kA]	5	5	5	5	6·4	6·4	6·4	
Thermal limit	I ² t [A ² s x 10 ⁶]	0·625	0·625	0·625	0·625	1·024	1·024	1·024	
20 °C phase resistance	R ₂₀ [mΩ/m]	5·278	5·278	5·278	5·278	2·891	2·891	2·639	
Phase resistance at thermal conditions	R _t [mΩ/m]	6·798	6·798	6·798	6·798	3·793	3·793	3·399	
Phase reactance (50Hz)	X [mΩ/m]	1·400	1·270	1·270	1·400	1·270	0·770	0·637	
Phase impedance	Z [mΩ/m]	5·461	5·429	5·429	5·461	5·429	2·992	2·715	
Resistance of the protective conductor ¹	R _{PE} [mΩ/m]	0·434	0·434	0·434	0·434	0·434	0·434	0·434	
Reactance of the protective conductor (50Hz)	X _{PE} [mΩ/m]	1·100	1·100	1·000	1·000	1·100	1·000	1·000	
Resistance of the fault loop	R _o [mΩ/m]	5·712	5·712	5·712	5·712	3·325	3·325	3·073	
Reactance of the fault loop (50Hz)	X _o [mΩ/m]	2·500	2·370	2·270	2·270	1·870	1·770	1·637	
Impedance of the fault loop	Z _o [mΩ/m]	6·235	6·184	6·147	6·147	3·814	3·766	3·482	
Voltage drop with distributed load	ΔV 10 ⁻³ cosφ = 0·70 [V/m/A]	4·07	3·99	3·99	4·07	3·99	2·23	2·23	1·99
	ΔV 10 ⁻³ cosφ = 0·75 [V/m/A]	4·23	4·16	4·16	4·23	4·16	2·32	2·32	2·08
	ΔV 10 ⁻³ cosφ = 0·80 [V/m/A]	4·38	4·32	4·32	4·38	4·32	2·40	2·40	2·16
	ΔV 10 ⁻³ cosφ = 0·85 [V/m/A]	4·52	4·46	4·46	4·52	4·46	2·48	2·48	2·23
	ΔV 10 ⁻³ cosφ = 0·90 [V/m/A]	4·64	4·59	4·59	4·64	4·59	2·54	2·54	2·30
	ΔV 10 ⁻³ cosφ = 0·95 [V/m/A]	4·72	4·69	4·69	4·72	4·69	2·59	2·59	2·34
	ΔV 10 ⁻³ cosφ = 1·00 [V/m/A]	4·57	4·57	4·57	4·57	4·57	2·50	2·50	2·29
Weight	ρ [kg/m]	1·80	1·83	2·02	2·02	1·98	2·33	2·33	
Fire load	[kWh/m]	1·1	1·1	2·1	2·1	1·1	2·1	2·1	
Protection index	IP	55	55	55	55	55	55	55	
Degree of impact-resistance	IK	7	7	7	7	7	7	7	
Joule effect losses at rated current	P [W/m]	12·7	12·7	12·7	12·7	18·2	18·2	40·5	
Ambient temperature min-/MAX·	t [°C]	-5/+50	-5/+50	-5/+50	-5/+50	-5/+50	-5/+50	-5/+50	

1 : metal casing

Temperature rating schedule according to the room temperature

Room temperature [°C]	15	20	25	30	35	40	45	50	55	60
K1 Factor	1·15	1·12	1·08	1·05	1·025	1	0·975	0·95	0·93	0·89

Multiplier coefficient of rated current for room temperature values different from 40° C

Mechanical loads permitted table

The table shows the maximum weights (kg) that can be supported, both for concentrated, and distributed loads

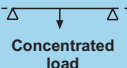
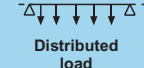
LB PLUS – TYPE B	LB PLUS – TYPE A	Distance between suspension brackets		
			Concentrated load	Distributed load
		1·5	40	50 kg/m (75 kg) ²
		2·0	30	30 kg/m (60 kg) ²
		3·0	20	13 kg/m (39 kg) ²
		5·0	13	5 kg/m (25 kg) ²
		7·0	7	2 kg/m (14 kg) ²

2 : Distributed load total weight

LB PLUS busbar trunking systems

technical information

■ LB PLUS – Type A – 252/254/404

1.5 m - 2 outlets (single sided only)

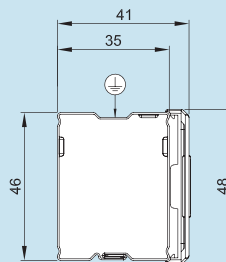
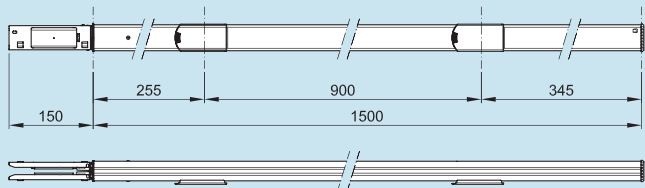

3 m - 2 outlets (single sided only)

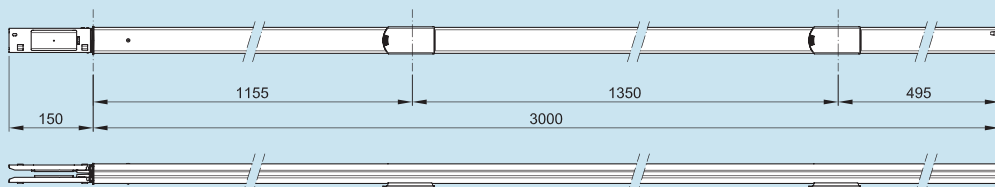

3 m - 4 outlets (single sided only)

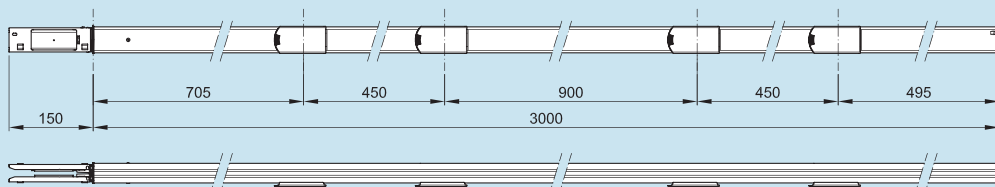

■ LB PLUS – Type B – 252/254/404

1.5 m - 2 outlets (single sided only)

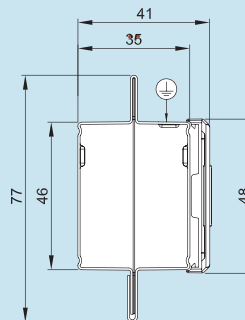
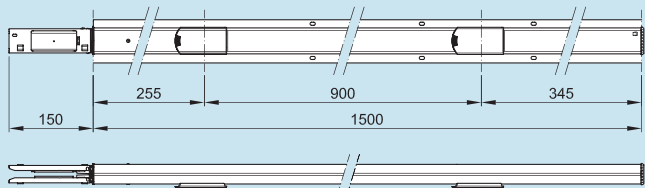

3 m - 4 outlets (single sided only)

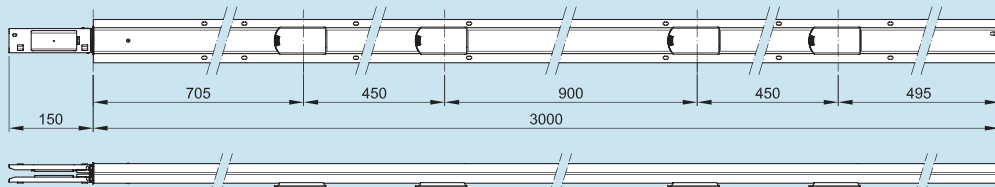

3 m - 6 outlets (single sided only)

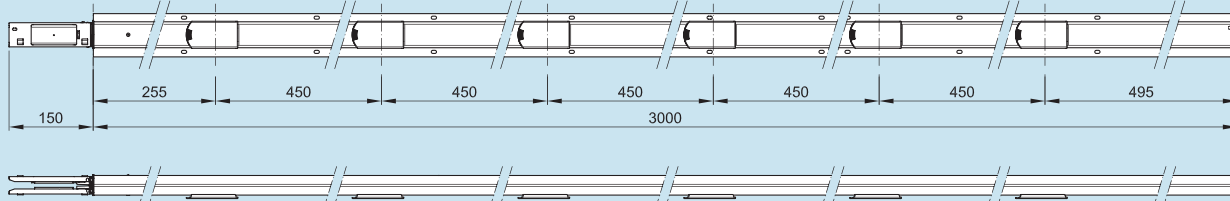

LB PLUS busbar trunking systems

technical information

■ LB PLUS – Type A – 256/258/408/634

1.5 m - 1+1 outlets (double sided)

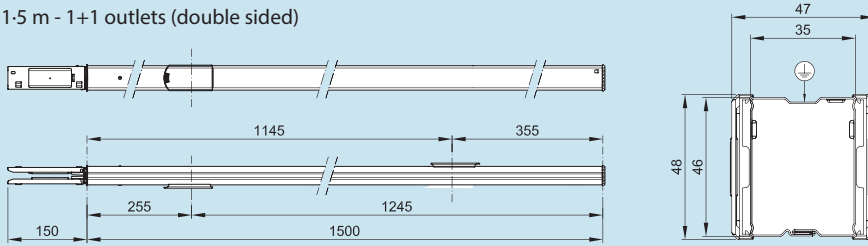

3 m - 2+2 outlets (double sided)

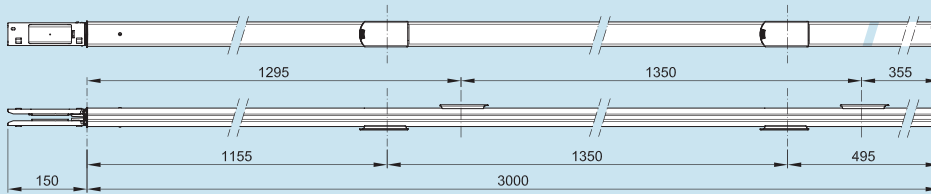

3 m - 4+4 outlets (double sided)

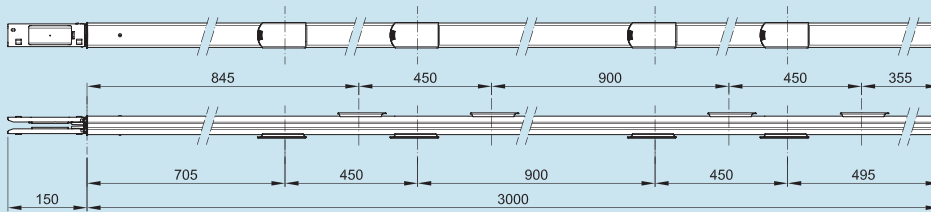

■ LB PLUS– Type B – 256/258/408/634

1.5 m - 1+1 outlets (double sided)

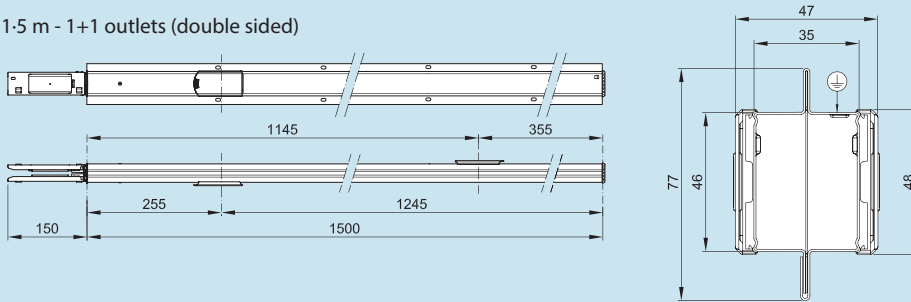

3 m - 4+4 outlets (double sided)

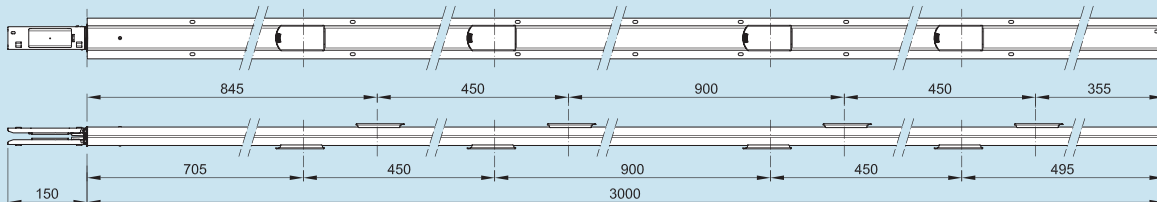

3 m - 6+6 outlets (double sided)

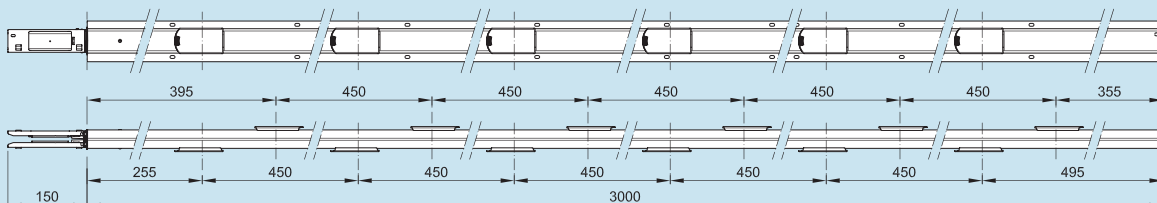

LB PLUS busbar trunking systems

technical information

Trunking components

FEED UNIT 254

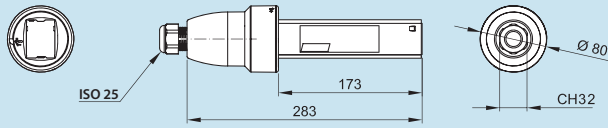

TERMINAL CAPACITY MIN 6 mm²
MAX 12 mm²
CABLE DIAMETER: MAX 18 mm

FEED UNIT 404 / 408 / 634

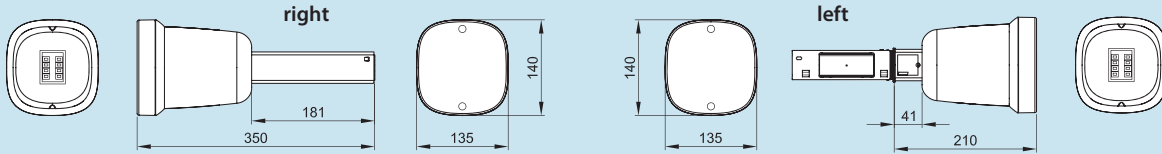

TERMINAL CAPACITY MIN 6 mm²
MAX 25 mm²
CABLE DIAMETER: MAX 32 mm

FLEXIBLE JOINT 404 / 408 / 634

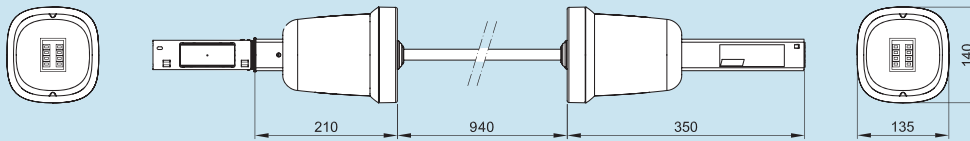

END CAP

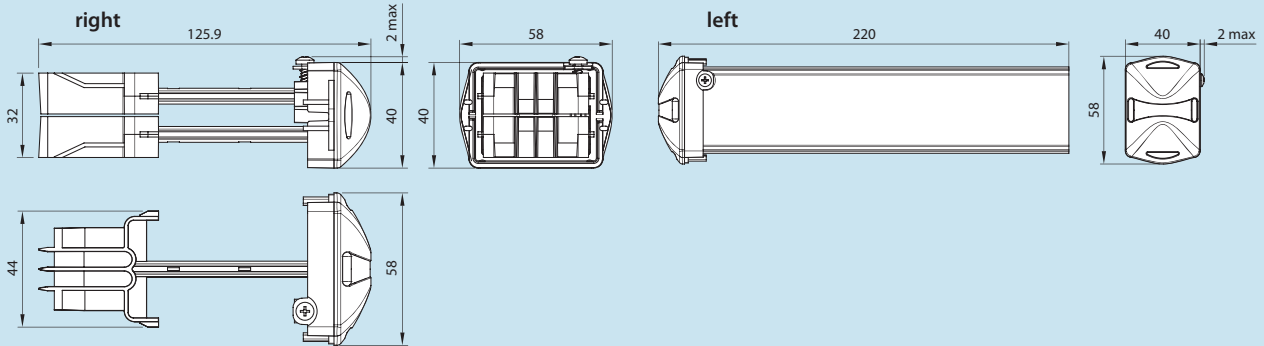

Tap-offs

PLUG 10A

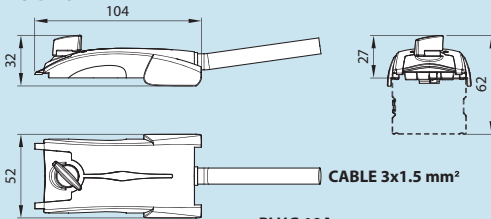

PLUG 10A
L1-N GREY
L2-N ORANGE
L3-N BLUE
L-N2 MAGENTA

PLUG 32A

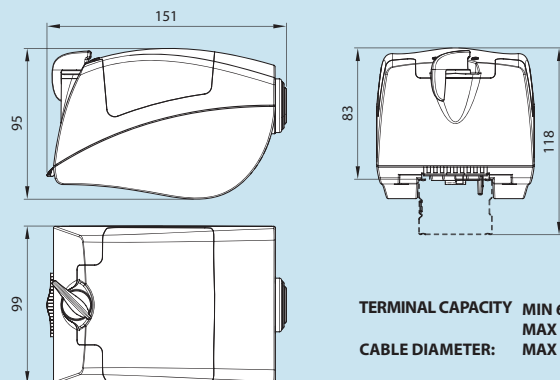

TERMINAL CAPACITY MIN 6 mm²
MAX 10 mm²
CABLE DIAMETER: MAX 25 mm

PLUG 16A

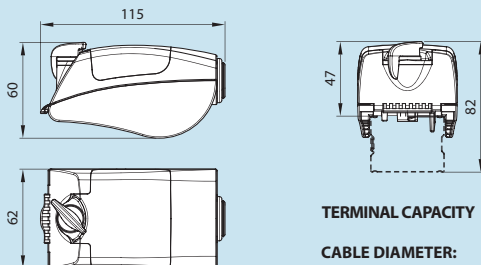

TERMINAL CAPACITY MIN 1.5 mm²
MAX 2.5 mm²
CABLE DIAMETER: MIN 8 mm
MAX 13 mm

Pre-wired 16 A tap-offs are supplied with 1.5 mm² SIHF cable

LB PLUS busbar trunking systems

technical information

■ Colour coding for 10 A single phase tap-offs

2 CONDUCTORS

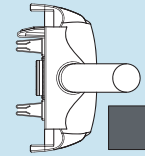
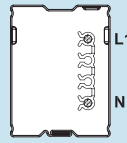

L1-N
75005011 / 75005021

4 CONDUCTORS
three-phase

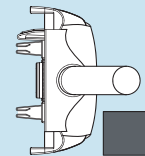
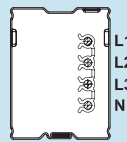

L1-N
75005011 / 75005021

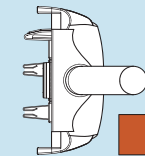

L2-N
75005012 / 75005022

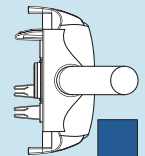

L3-N
75005013 / 75005023

4 CONDUCTORS
dual single phase

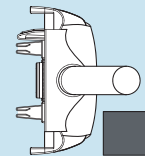
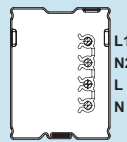

L1-N
75005011 / 75005021

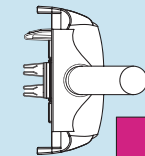

L-N2
75005014 / 75005024

6 CONDUCTORS

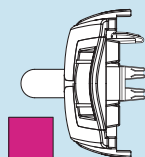

L-N2
75005014 / 75005024

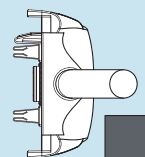
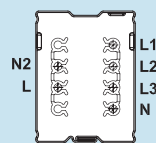

L1-N
75005011 / 75005021

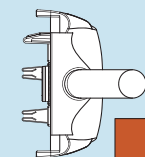

L2-N
75005012 / 75005022

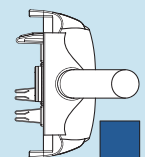

L3-N
75005013 / 75005023

8 CONDUCTORS

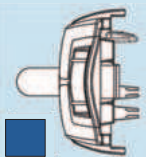

L3-N
75005013 / 75005023

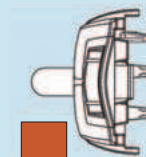

L2-N
75005012 / 75005022

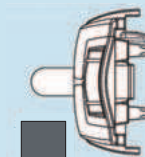

L1-N
75005011 / 75005021

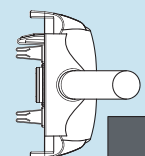
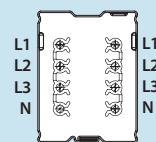

L1-N
75005011 / 75005021

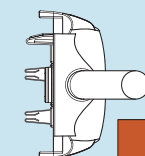

L2-N
75005012 / 75005022

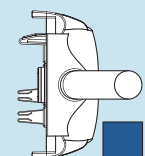

L3-N
75005013 / 75005023

4 x SINGLE PHASE

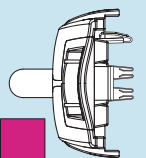

L-N2
75005014 / 75005024

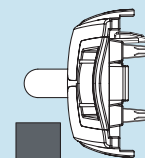

L1-N
75005011 / 75005021

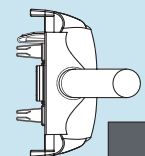
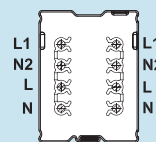

L1-N
75005011 / 75005021

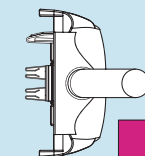

L-N2
75005014 / 75005024

LB PLUS busbar trunking systems

technical information

■ Hangers and cable channel

60 kg suspension bracket for Type A busbar Cat. No. 75003000

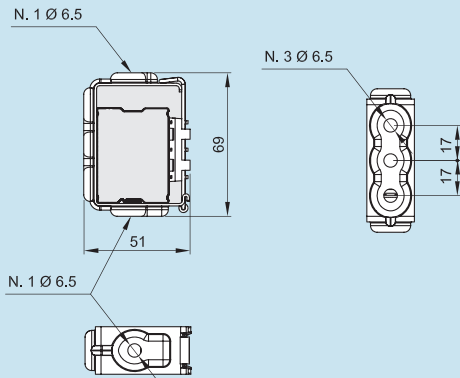

60 kg suspension bracket for Type B busbar Cat. No. 75003004

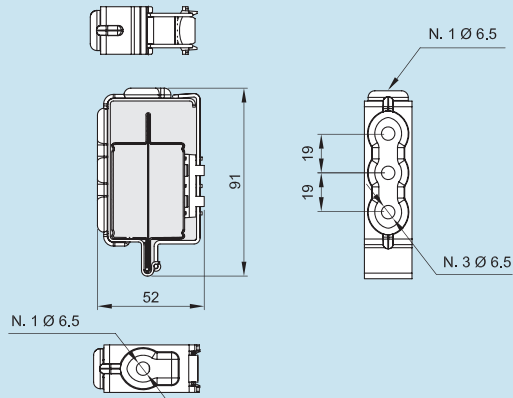

Hook for lamp Cat. No. 75003001

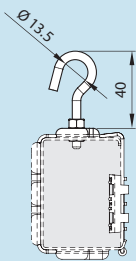

Ring Cat. No. 75003002

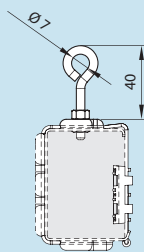

Pig tail for chain Cat. No. 75003005

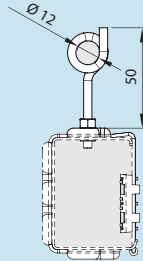

Bracket with 3 m steel cable for Type A busbar Cat. No. 75003009

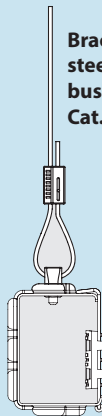

5 m steel cable with self-locking clamp for Type B busbar Cat. No. 75003008



Bracket for cable channel

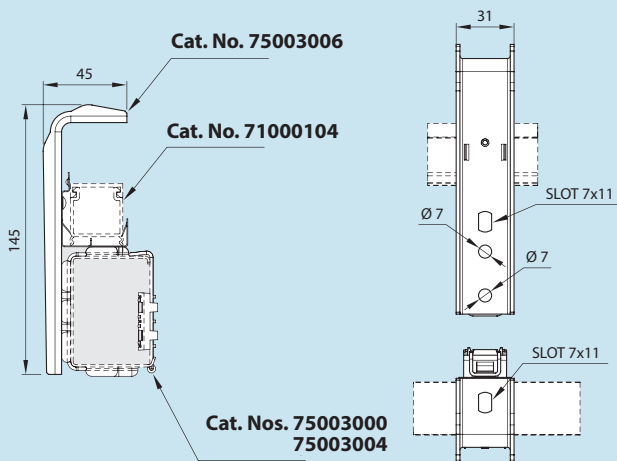

PVC cable channel with cover Cat. No. 71000104

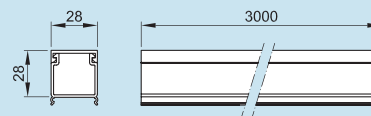

LB PLUS busbar trunking systems

installation methods

LB PLUS requires a fixing bracket Cat. No. 75003000 for Type A and a fixing bracket Cat. No. 75003004 for Type B
Both brackets come with a 6.5 mm Ø hole and can be fixed to 6 mm² threaded rod

■ Suspension

For suspension, the bracket must be fitted with a range of appropriate accessories, which must be added according to the installation requirements

Ceiling suspension of LB PLUS Type A

Pigtail for chain

This solution is possible by ordering suspension bracket item Cat. No. 75003000 and accessory Cat. No. 75003005, preset for the connection of a chain



Bracket with steel cable

This solution is already supplied as a kit Cat. No. 75003009, consisting of a suspension bracket and a 3 m steel cable



Ceiling suspension of LB PLUS Type B

5 m cable with self locking clamp

This accessory Cat. No. 75003008 allows the suspension of the reinforced (Type B) straight lengths using the slots along the reinforcement plate at the top of the bar

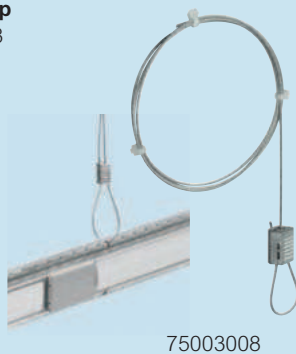

■ Suspension of light fittings

LB PLUS - single and double sided

For the suspension of light fittings, use hook Cat. No. 75003001 or ring Cat. No. 75003002
These accessories can be installed on the brackets used for the suspension of the busbar (Cat. Nos. 75003000 and 75003004).

