

A close-up, vertical view of the layers of a plywood sheet, showing the natural wood grain and the alternating light and dark bands of the veneers.

Latvijas Finieris

plywood handbook

2017

Proposals

Please send any proposals and comments to info@finieris.lv with reference Handbook.

Warning

Plywood Handbook reproduction, even partial, requires a written permission from Latvijas Finieris.

© 2017, Latvijas Finieris

P L Y W O O D H A N D B O O K

Introduction

At Latvijas Finieris our conviction that plywood production and plywood product development is a continual process is proven by long experience giving us an ever broader and better knowledge of customer needs and how to achieve them.

Therefore we have created the third edition of our Plywood Handbook which is an essential guide for manufacturers, specifiers, and indeed, all buyers.

The information and data enclosed has been obtained from the results of tests carried out at Latvijas Finieris laboratories and in cooperation with various research institutes. Our specialists take an active role in European and national standardisation work and that allows us to choose and use the most appropriate test methods. The Plywood Handbook demonstrates that standardisation is a necessary and integral part of the international communication and comparison process.

Birch plywood is increasingly used in more varied industries and for more varied applications so those who are not familiar with the woodworking industry are especially in need of information about its properties, application and conformity to international standards. This information is provided in our Plywood Handbook with the aim of promoting birch plywood and its unique properties as well as to answer any questions asked by our cooperation partners.

Jānis Ciems
CEO
Latvijas Finieris



enterprise

history of plywood production	1-1
profile of enterprise	1-3
quality	1-4
protection of environment	1-4
CE marking	1-4
certificates	1-6
research	1-8

products

production process	2-1
types of products	2-3
product grades	2-6
dimensions and structure	2-11
gluing	2-13
biological durability	2-13
formaldehyde emission	2-15
pentachlorophenol (PCP) content	2-17
moisture content	2-17
density	2-17
production control	2-17
screw withdrawal force	2-20

characteristics of products

statistical processing of data	3-1
wear resistance of overlaid plywood	3-2
the effect of loaded heavy duty castors on overlaid plywood	3-4
reaction to fire	3-5
friction	3-8
chemical stability of overlaid plywood	3-10

mechanical properties

4-1

5 6 7

design

general explanatory notes	5-1
uniform load	5-3
floors - uniform load	5-4
concrete formworks - uniform load	5-8
concentrated load	5-10
concentrated load over an area 50×50 mm	5-11
concentrated load over an area 80×180 mm	5-15

application

packaging, storage, acclimatisation, transport	6-1
machining	6-4
finishing	6-5
installation	6-5
main plywood applications	6-9

literature

7-1



enterprise

history of plywood production	1-1
profile of enterprise	1-3
quality	1-4
protection of environment	1-4
CE marking	1-4
certificates	1-6
research	1-8

1.1. History of plywood production in Latvia

The plywood production in Latvia dates back to 1873, the year when the Joint Stock Company Latvijas Berzs was founded. In the very beginning the products were blackboards for schools and pencils for carpenters, but in 1909 a hydraulic press was installed and plywood production started.

In 1913 there were three plywood mills in Latvia, with an annual output of 50'000m³. The 1923 founded Furniers mill was the largest manufacturer for export at that time. The Furniers product range included special plywood for aviation as well.

In 1929 the Joint Stock Company Lignums was founded. It was at that time the most modern production unit, with an annual output of 15'000m³. Besides standard products, Lignums manufactured also aviation and water-proof grades.

In 1940, the three largest factories, together with 10 smaller mills, employed some 3000 people. The annual output was 83'000m³ and half of it was exported mainly to UK, Germany and Denmark. The plywood production was based purely on Latvian birch logs. The Latvian plywood production developed and the volumes increased until the beginning of World War II. In 1940 the Joint Stock Companies were transformed into State-Owned Enterprises.

During the Soviet occupation (1945-1991) the Latvian plywood mills concentrated to producing mainly low quality packaging plywood out of Russian (70%) roundwood. The major part was sold to the Republics of the Soviet Union (Russia, Ukraine, Georgia, Azerbaijan, Moldavia, Uzbekistan, etc.) and only 15% was exported to Western Europe through Exportles - the centralised Soviet wood products export organisation.

After World War II until 1975 four factories produced plywood in Latvia, mainly 1525 x 1525 mm interior grade. These factories were Latvijas Berzs, Lignums, Furniers in Riga and Vulkans in Kuldiga.

In 1975 three manufacturers (Latvijas Berzs, Lignums and Furniers) jointly established the Plywood Production Union of Latvia, a State-Owned Enterprise. By the end of 80's, plywood production in Latvia declined significantly, the collapse of the Soviet Union had started to approach.

Latvia re-gained independence in 1991. In 1992 a Private Joint Stock Company Latvijas Finieris was founded. This new company with long traditions in plywood manufacture gathered together the mills Furniers, Lignums and Latvijas Berzs.

The range of plywood products was rapidly expanded to include interior and exterior plywood, overlaid plywood, plywood veneered with precious wood, varnished and painted plywood and plywood for laser cutting. Latvijas Finieris wants to be a stable employer, as well as a long-term partner for people who grow forests and who purchase its products. The company goals include becoming the world's leading developer and supplier of birch plywood products and related services.

The extensive benefits of the expertise in plywood business have enabled Latvijas Finieris to expand and develop and to become a significant market player.

Birch plywood production still presents considerable development opportunities. We believe that it is, and will remain, one of the most beneficial uses of birch wood.

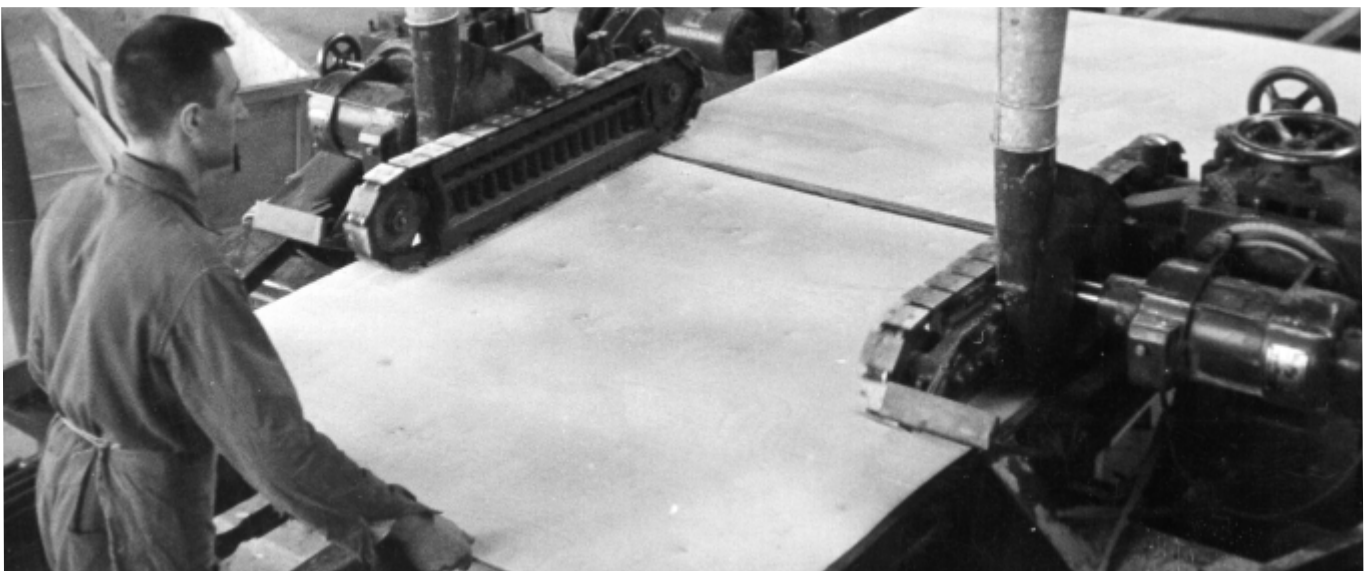

Figure 1.1. Plywood production in Latvia from 1913 to 1940, 1000m³

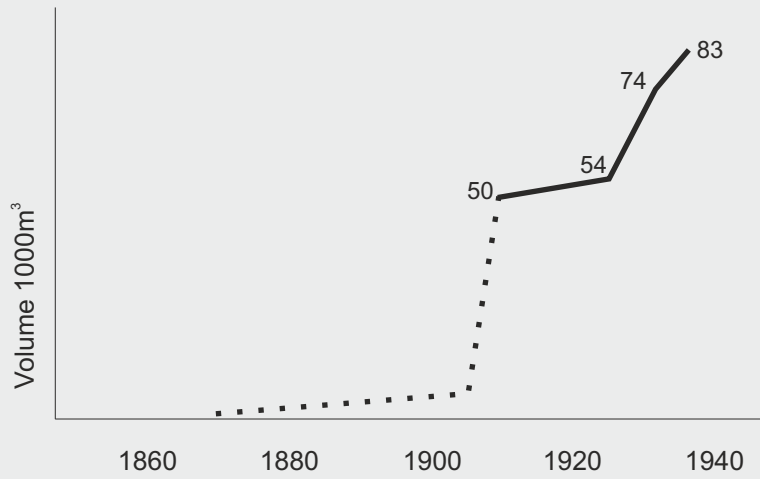

Figure 1.2. Volume of production of glued products in Latvia (as part of the Soviet Union), 1000m³

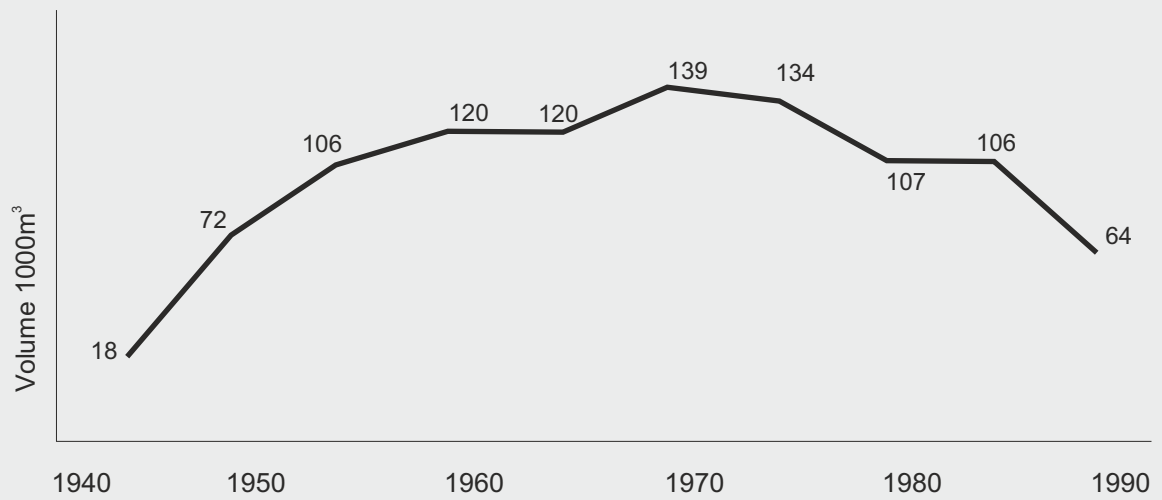
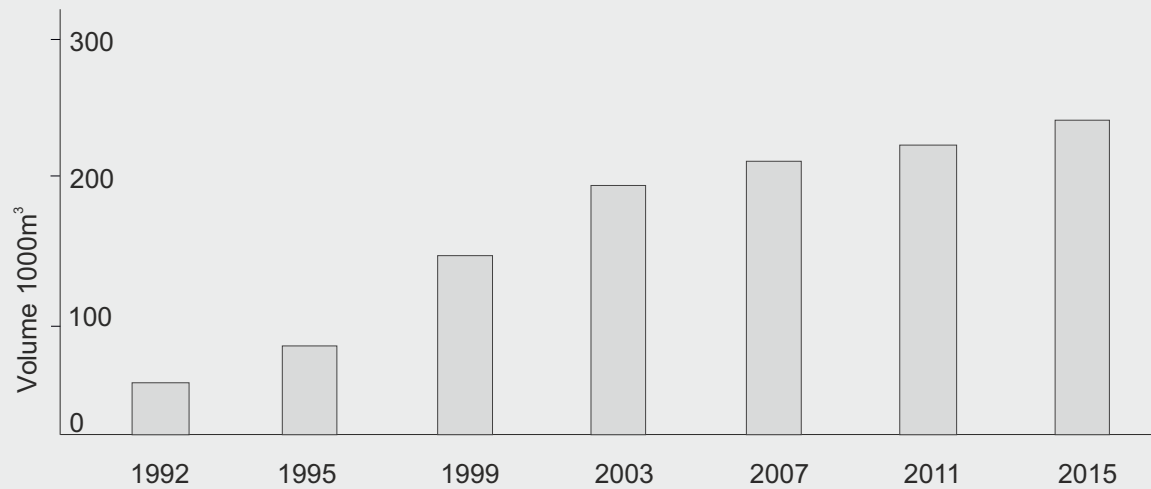

Figure 1.3. Latvijas Finieris production of glued products, 1000m³



1.2. Profile of enterprise

The business activities of Latvijas Finieris in Latvia cover the entire value chain, from birch nursery and planting to manufacture of a wide range of specialised plywood products.

The presence of Latvijas Finieris in the world wide markets is assured with active contacts with business partners in more than 50 countries. The network of own Riga Wood sales and product development offices cover the key markets - Germany, Italy, Sweden, Finland, France, Spain, Portugal, Turkey, U.K., The Netherlands, Denmark, Norway, Japan, U.S., Switzerland, Austria, The Czech Republic, Slovenia, Hungary, Belgium, Ireland, Estonia, Lithuania and Latvia.

Figure 1.4. Business activities of Latvijas Finieris in Northern Europe

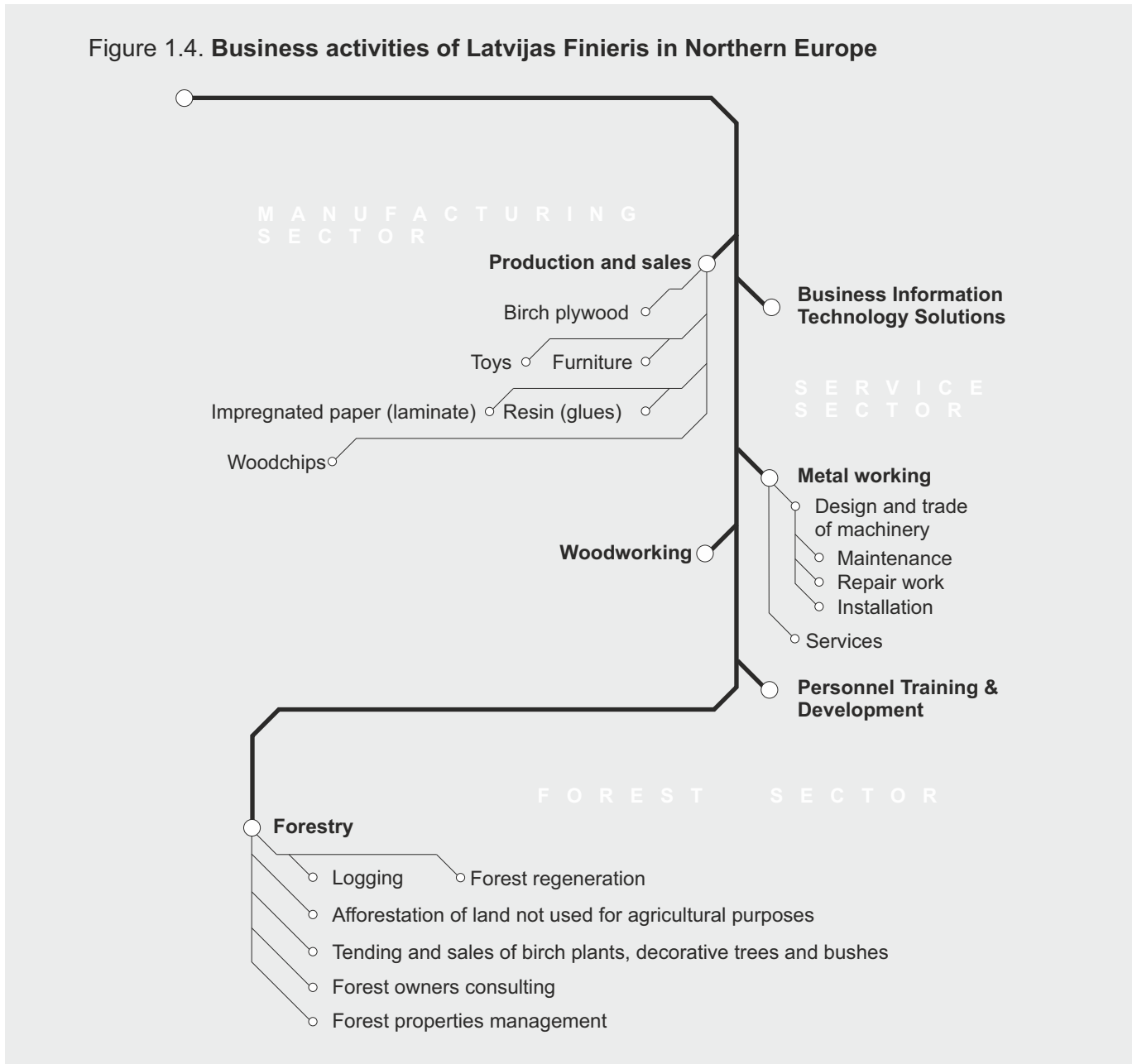

Today Latvijas Finieris is a substantial industrial concern with five plywood mills (Lignums, Furniers, Verems, Sastamala and Kohila), and two further processing plants (Hapaks and Troja).

Latvijas Finieris strengthens itself as a leading producer of birch plywood on a Baltic region scale - existing five factories in Latvia and one in Lithuania, Estonia and Finland.

During the years of Latvijas Finieris existence the company has become a producer of technically demanding plywood suitable for various industrial applications - the market share of Latvijas Finieris products in the European markets is significant.

1.3. Quality

The modern business environment is rapidly changing. Requirements of customers and other business partners for the quality of products are increasingly multiple. In order to match with this, Latvijas Finieris effectuates continuous controls throughout the well-structured production process. In addition, testing of ready-made products is carried out in Latvijas Finieris laboratories.

Since 1999 Quality Management System of Latvijas Finieris is certified in accordance with ISO 9001 requirements by certification body Bureau Veritas Certification.

1.4. Protection of environment

Latvijas Finieris has established strict measures in order to guarantee that the production processes are harmless for human health as well as for environment. In addition, Latvijas Finieris implements and supports sustainable forest management system which is friendly for the nature and the surrounding societies.

Since 2003 the Lignums mill is certified by Bureau Veritas Certification to meet the requirements of the Environment Protection System ISO 14001.

Latvijas Finieris Energy management system is certified by Bureau Veritas as complying to ISO 50001. The certificate demonstrates that the company follows systematic approach in achieving continual improvement of energy performance, including energy efficiency, security, use and consumption. This gives more confidence to customers, stakeholders and employees that the company continually reduces its energy use and greenhouse gas emissions.

Latvijas Finieris holds the Forest Stewardship Council (FSC) and Program for the Endorsement of Forest Certification (PEFC) certificates confirming that the Latvijas Finieris timber processing system, from logging to manufacture and delivery, meets the internationally recognised sustainable forest management principles.

Latvijas Finieris acknowledges and vigorously applies the European Union initiatives about the legality of timber sources.

According to the Latvijas Finieris purchasing policy, the company accepts roundwood exclusively from legal and verified sources, with all taxes and fees paid. Specialists of Latvijas Finieris make regular supply and supplier audits, in order to assure that they meet FSC or PEFC requirements.

Figure 1.5. Certification of systems and production at Latvijas Finieris

Plywood, production systems
of plywood, planning and
supply certified by:



Latvijas Finieris ensures consistent quality of its products and services, the competitiveness of its products and guarantees that the operations are environmentally friendly. Independent reports conclude that the products manufactured by Latvijas Finieris and services offered meet the requirements of legislation and international standards and that these have been made by independent certification institutions, state inspections as well as our cooperation partners.

1.5. CE marking

EU Regulation No.305/2011 of the European Parliament and of the Council laying down harmonized conditions for the marketing of construction products and repealing Council Directive 89/106/EEC has come into force since March 2011.

Regulation determines basic requirements relating to the mechanical and fire resistance for construction works, as well as to the essential aspects of public benefit relating to sustainable use of natural resources, energy economy, heat retention, protection against noise, health, hygiene and other issues.

Compliance of plywood to the Regulation should be demonstrated by meeting requirements of the EN 13986 Wood-based panels for use in construction – Characteristics, evaluation of conformity and marking.



Timber Purchasing Policy

AS "Latvijas Finieris" undertakes purchasing timber for production purpose only from suppliers who guarantee with adequate documents both its legal origin and the implementation of sustainable forest management principles.

As controlled timber the company will use:

- Timber supplied from forests according to FSC and PEFC controlled timber criteria when supplier can verify the origin of wood throughout the whole supply chain in accordance with AS "Latvijas Finieris" developed wood legitimacy system. The system in function is based on corporate responsibility and can be verified and confirmed by an external party or the authorities.
- AS "Latvijas Finieris" confirms that company purchasing and manufacturing processes comply with requirements of EU Timber Regulation Nr.995/2010.

Information regarding AS "Latvijas Finieris" chain of supply is publicly available.

CEO

Riga 2015

Jānis Ciems



Criteria for Purchasing FSC Controlled Wood

In accordance with the FSC standard, the company will not use wood from the following categories:

- illegally harvested wood;
- wood harvested in violation of traditional and civil rights;
- wood harvested in forests where high conservation values are threatened by management activities;
- wood harvested in forests being converted to plantations or non-forest use;
- wood from forests in which genetically modified trees are planted.

CEO

Riga 2015

Jānis Ciems

1.6. Certificates

Independent conclusions concerning the Latvijas Finieris products conformity with requirements of different norms and international standards have been provided by:

- Fraunhofer Wilhelm Klauditz Institut, Germany;
- Entwicklungs- und Prüflabor Holztechnologie GmbH, Germany;
- Forest and Wood Product Research and Development Institute – MEKA;
- Latvian State Wood Chemistry Institute;
- Berufsgenossenschaftliches Institut für Arbeitsschutz – BIA;
- Bundesanstalt für Materialforschung und prüfung (Federal Institute for Materials Research and testing) – BAM;
- Swedish Institute for Wood Technology Research – TRATEK;
- Swedish National Testing and Research Institute – SP;
- Technical Research Centre of Finland – VTT;
- Danish Technological Institute – DTI;
- Centre Scientifique Et Technique du Bâtiment – CSTB;
- Scientific and technological research centre of the Belgian textile industry – Centexbel;
- Japan Ministry of Land, Infrastructure, Transport and Tourism;
- Japan Testing Center of Construction Materials;
- GOCT P, Russian State Standard Certification System;
- Universität Hamburg, Zentrum Holzwirtschaft;
- Laboratorio Prevenzione Incendi LAPI;
- SGS Institut Fresenius, Germany;
- Centro Ricerche-sviluppo e laboratori prove CATAS, Italy.



1.7. Research

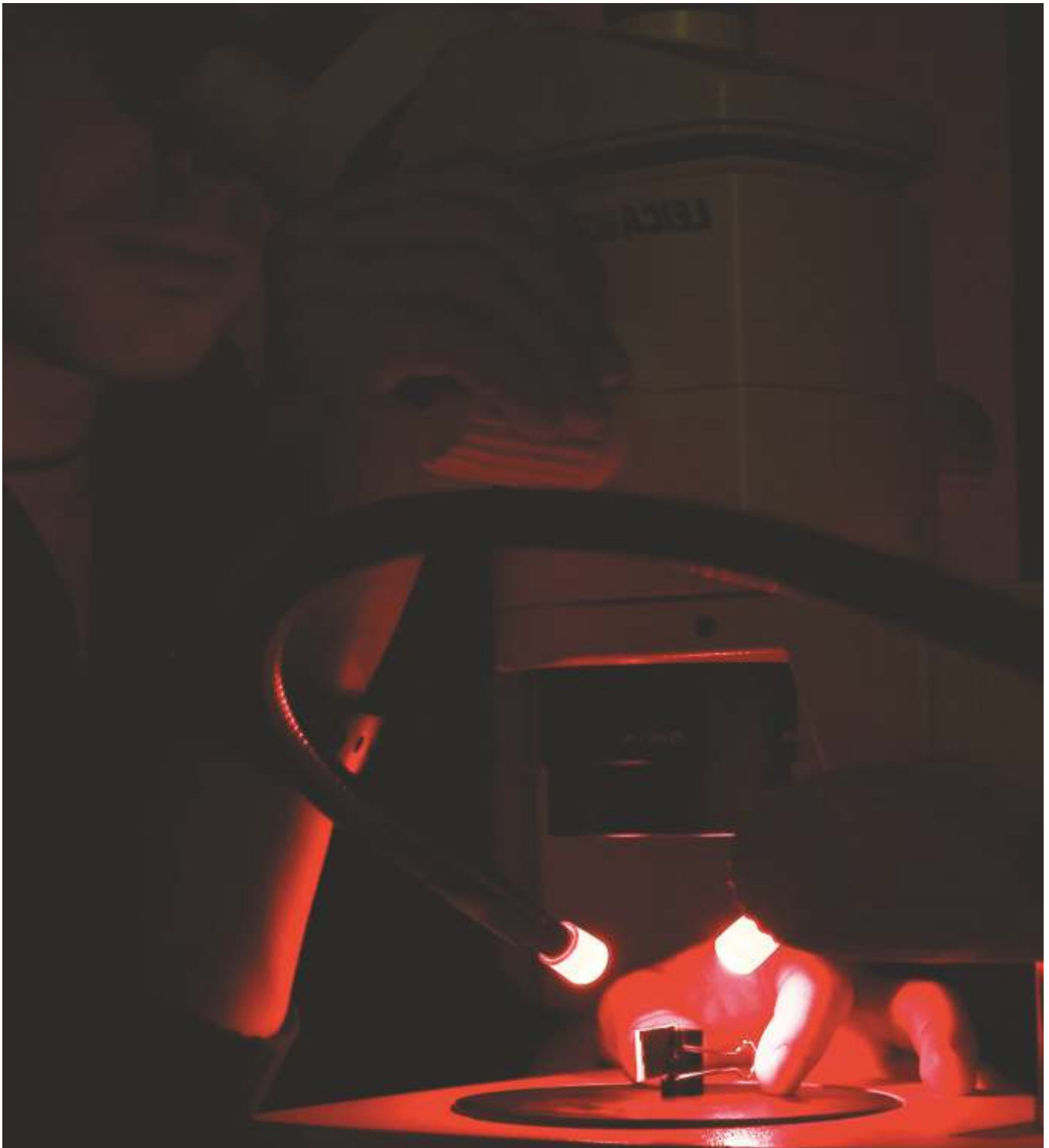

Latvijas Finieris
laboratories focus on:

- 1 product quality control in accordance with EN 13986 Wood-based panels for use in construction - Characteristics, evaluation of conformity and marking;
- 2 new products development;
- 3 improvement of production technologies.

1.7.1. Capabilities of Latvijas Finieris Laboratory Units

Along the plywood production lines there are laboratory units designed for product quality indices monitoring. Samples of average dimensions can be tested at the laboratories in accordance with EN 789 at maximum loading force up to 40 t, tests of wear resistance of different coatings and other tests. There are chambers for sample acclimatization under different weather conditions; simulation of UV radiation effect is possible. Test data is stored and processed for the analysis of test results. Taking into account importance of the laboratories, they are fit out with the testing equipment appropriate to production requirements.

The highly qualified laboratory staff has well established contacts with the academic staff at various institutes and universities. Employees make tests in accordance with internationally recognised or self-developed methods. Using equipment of the laboratory, students of Forest Faculty of Latvia University of Agriculture (LLU) carry out research work aiming at defence of Bachelor's, Master's or Doctor's Degrees.

1.7.2. Product Development System

The Latvijas Finieris Product Development System offers a well-structuree framework for successful product development processes. These processes aim at finding solutions to fulfil new product and quality requirements identified in the market. The Latvijas Finieris world-wide network of own sales offices is the main vehicle in observing the current and future needs of the Latvijas Finieris key industrial customers, and the general trends in the marketplace.

Latvijas Finieris considers the product as new or innovative if this product or service is developed or provided by Latvijas Finieris and offers new possibilities to the customer or production process.

The Latvijas Finieris Product Development System framework, Figure 1.6., well defines the appropriate order of development sub-procedures. In order to develop a new product one has to react actively to market impulses, to evaluate several ideas and to look through many projects aiming at wider plywood application and new market requirements. By following this marching order process will be based on adequate initial information input, minimizing the risk of interpretation errors. Thus the product development system in Figure 1.6. forms a pyramid.

The Latvijas Finieris Product Development System includes market survey, analysis of a new product cost competitiveness and sales potential, production technology development, laboratory tests and analysis, planning of projects and their implementation, and finally preparation of marketing plans.

Figure 1.6. New Product Development System

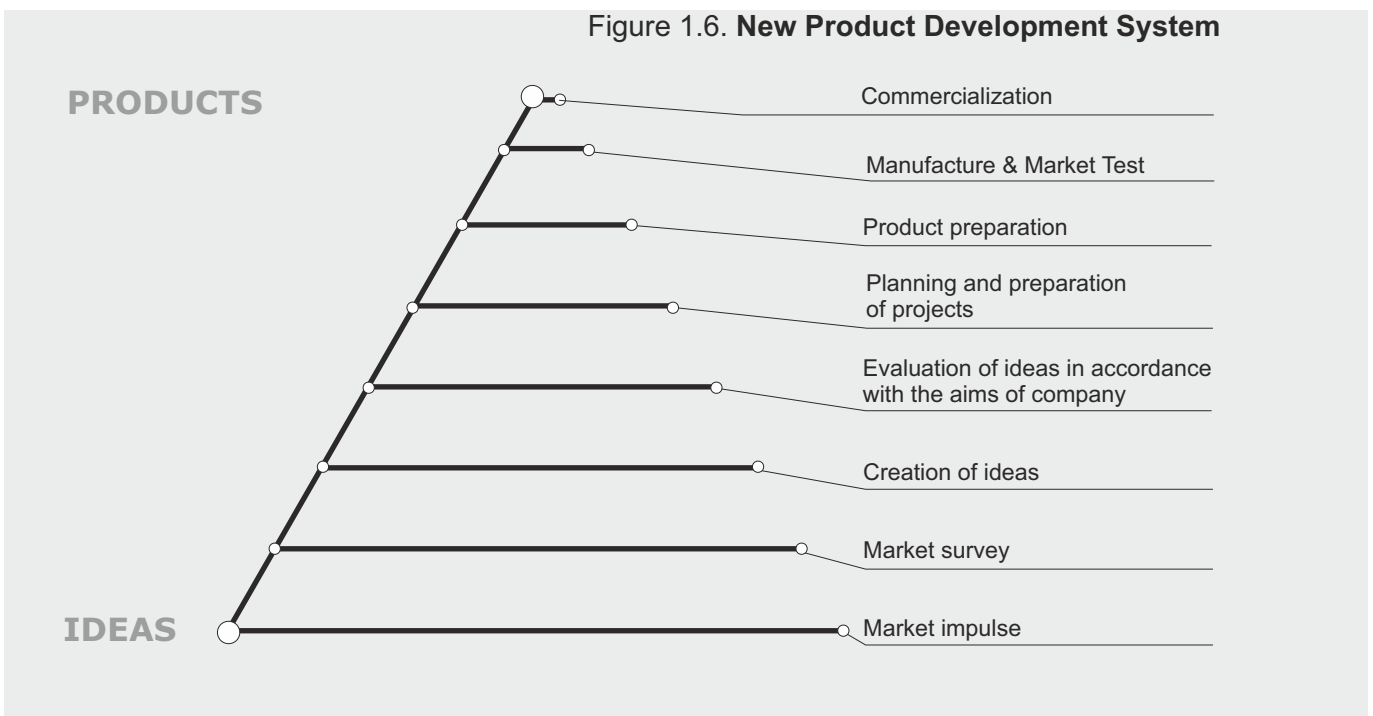

1.7.3. Latvijas Finieris Birch Program

Latvijas Finieris is the number one birch processing enterprise in Latvia and holds a significant position in the Latvian forest industry. The company exclusively uses raw material from sources in conformity with sustainable and long term forest management principles.

The company is actively involved in vertical integration requiring forestry management and development, aiming at reproduction of natural resources, maintenance of the biodiversity of forests and of stability of the ecological system.

In 1996 Latvijas Finieris introduced the Birch Program, to promote birch growing and to establish high quality and efficient extensions to Latvian birch plantations. The main lines of the program are shown in Figure 1.7.

Figure 1.7. The main lines of the Birch Program

- | | | | | | |
|--------------------------------------|-------------------------|---|---|---------------------------------------|--------------------------|
| Development of birch plant selection | Growing of birch plants | Converting unused agricultural land to fast-growing birch plantations | Enhancing the growth of birch trees in the existing plantations | Research in the above mentioned areas | Decisions on development |
|--------------------------------------|-------------------------|---|---|---------------------------------------|--------------------------|

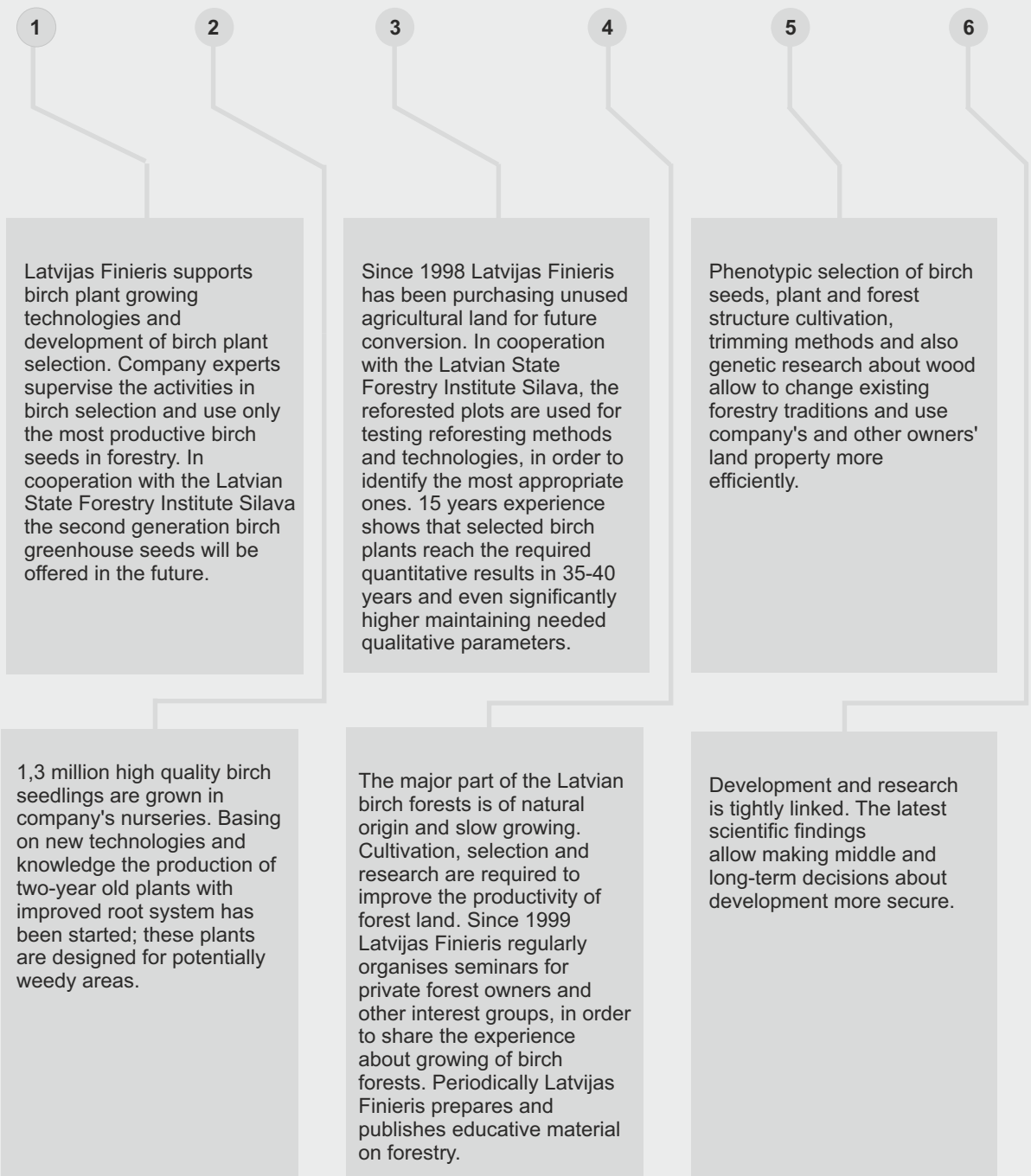

1
Latvijas Finieris supports birch plant growing technologies and development of birch plant selection. Company experts supervise the activities in birch selection and use only the most productive birch seeds in forestry. In cooperation with the Latvian State Forestry Institute Silava the second generation birch greenhouse seeds will be offered in the future.

3
Since 1998 Latvijas Finieris has been purchasing unused agricultural land for future conversion. In cooperation with the Latvian State Forestry Institute Silava, the reforested plots are used for testing reforestation methods and technologies, in order to identify the most appropriate ones. 15 years experience shows that selected birch plants reach the required quantitative results in 35-40 years and even significantly higher maintaining needed qualitative parameters.

5
Phenotypic selection of birch seeds, plant and forest structure cultivation, trimming methods and also genetic research about wood allow to change existing forestry traditions and use company's and other owners' land property more efficiently.

1,3 million high quality birch seedlings are grown in company's nurseries. Basing on new technologies and knowledge the production of two-year old plants with improved root system has been started; these plants are designed for potentially weedy areas.

4
The major part of the Latvian birch forests is of natural origin and slow growing. Cultivation, selection and research are required to improve the productivity of forest land. Since 1999 Latvijas Finieris regularly organises seminars for private forest owners and other interest groups, in order to share the experience about growing of birch forests. Periodically Latvijas Finieris prepares and publishes educative material on forestry.

6
Development and research is tightly linked. The latest scientific findings allow making middle and long-term decisions about development more secure.





products

production process	2-1
types of products	2-3
product grades	2-6
dimensions and structure	2-11
gluing	2-13
biological durability	2-13
formaldehyde emission	2-15
PCP content	2-17
moisture content	2-17
density	2-17
production control	2-17
screw withdrawal force	2-20

2.1. Overview on the production process

Before entering to the production line the quality graded logs go through a hydro-thermal processing in warm water ponds, in order to enhance the woods plasticity. This contributes to the peeling results and to the quality of veneer.

After the hydro-thermal processing the logs are debarked and cut-to-length. Before the rotary peeling the logs are centralised with the help of laser devices, in order to maximize the yield of veneer.

The rotary cut veneer sheets are cut into required lengths and kiln dried. The dry veneer is quality graded and sorted according to format. Veneers with too high moisture are put aside for further drying. Veneers not meeting the strict quality and dimension requirements will not be forwarded to plywood production.

Veneers are then cut-to-size, defects eliminated, knots are patched and sheets are jointed according to needs. Dry, graded and sorted veneers are fed to plywood lay-up lines. Glue is applied on veneers and plywood lay-up of full format and appropriate construction is made.

Figure 2.1. Plywood production diagram

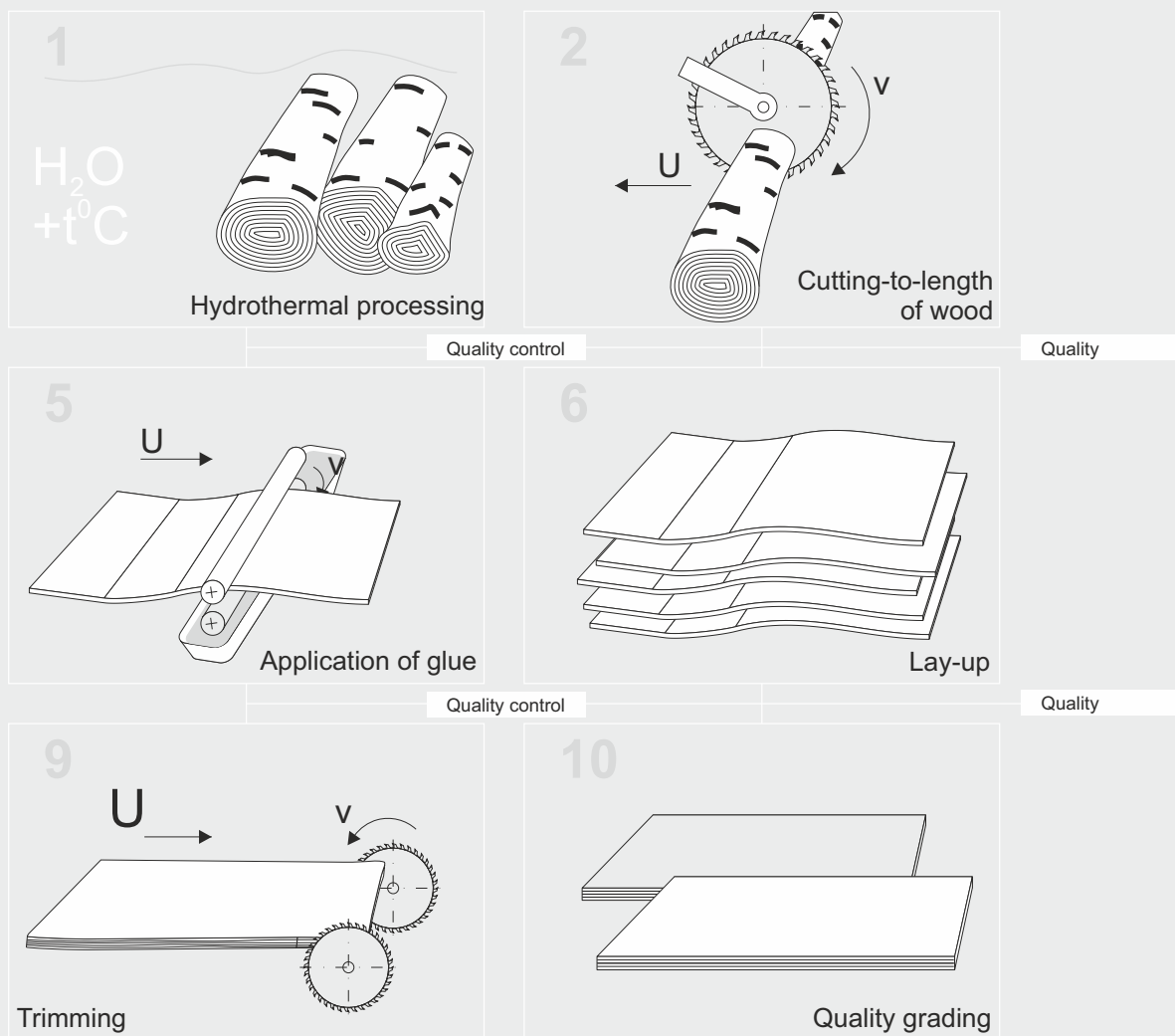

After lay-up the cold pre-pressing takes place, in order to prepare the panels for hot pressing. Hot pressing is the part of the process where plywood panels are made. A multi day light hot press creates and maintains the required contact between the glue and the veneers. It also decreases the tension in the glue line and the thickness of glue layer.

After hot pressing, and before further processing, the panel' temperature, moisture content and dimensions have to stabilise. When stabilised, the panels are trimmed from all four sides. The faces are sanded to reach accurate panel thickness and to decrease thickness variations.

After sanding, the panels are quality graded and packaged in accordance with dimension and quality.

Raw plywood may be overlaid with various materials for different end-uses. The panels can also be machined (cut-to-size, profiled, drilled, etc.).

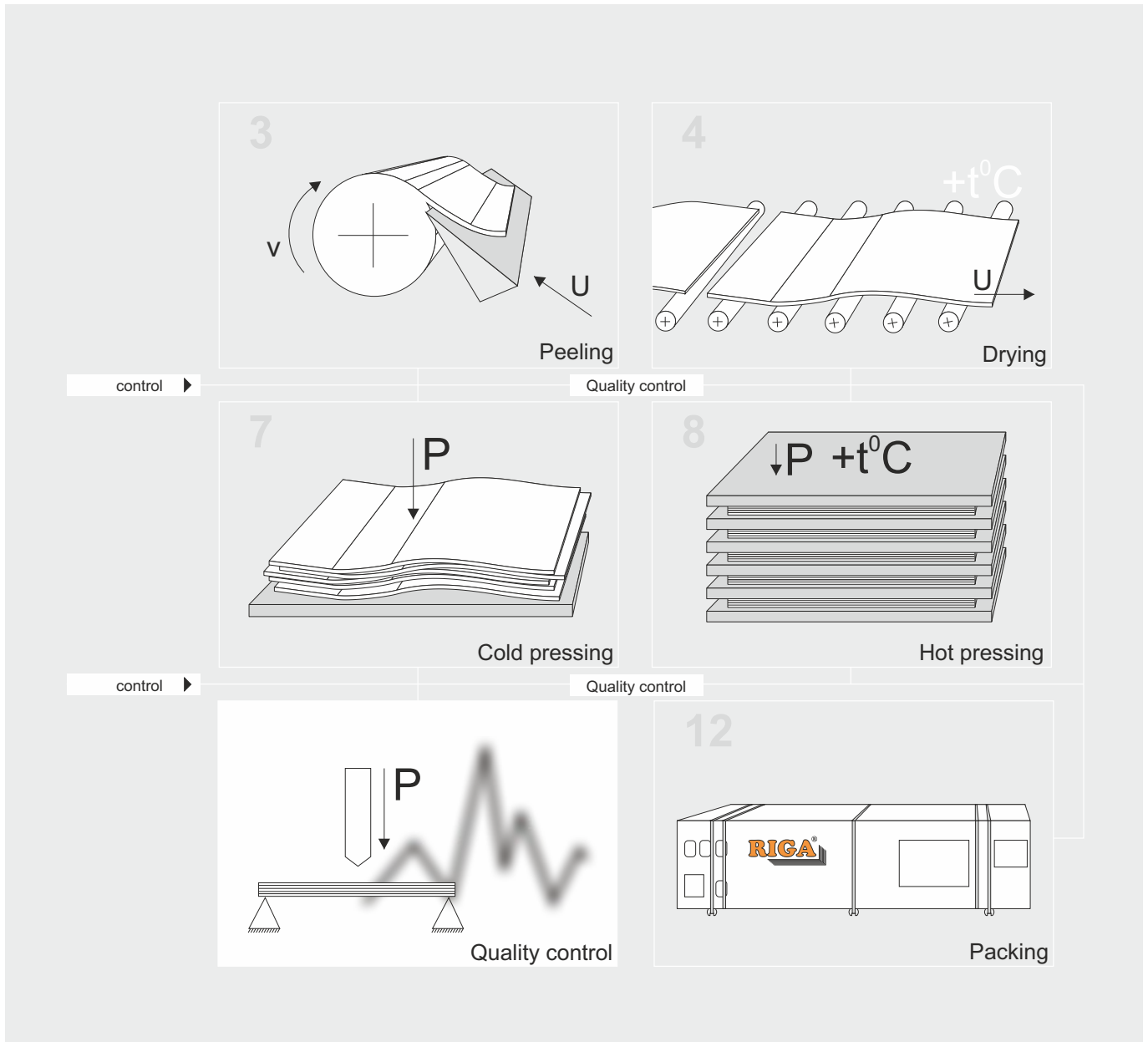

2.2. Types of products

Figure 2.2. Groups of Plywood Products

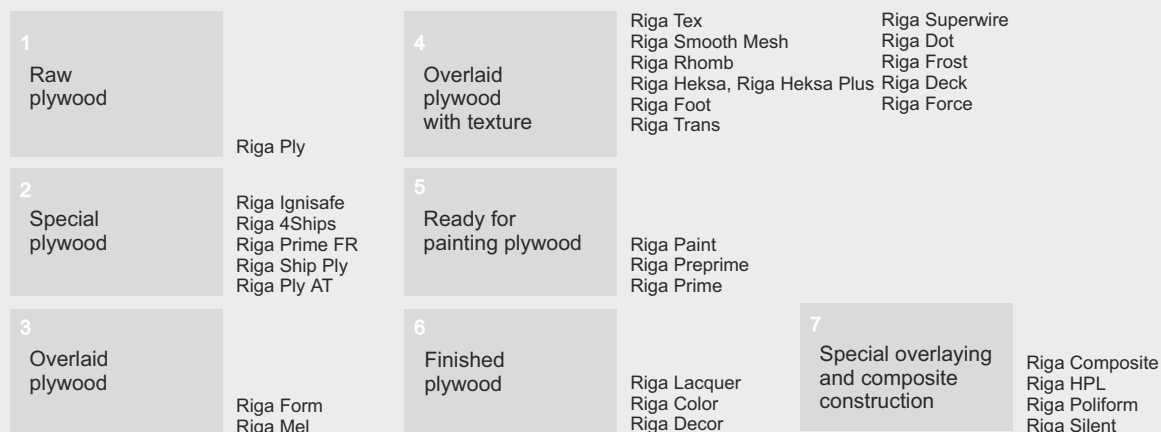

Raw plywood

Riga Ply - birch plywood made of 1.4 mm peeled veneer using phenol-formaldehyde resin based glue. The plies are cross-bonded but customised constructions can also be made. This plywood is the basis for all other types of plywood products. Plywood grades are presented in Table 2.2.

Special plywood

Riga Ignisafe - birch plywood (Riga Ply) impregnated with fire retardant. Riga Ignisafe is without overlay or is overlaid on one face with a dark brown phenol film.

Riga Prime FR - birch plywood (Riga Ply, BB) overlaid with a fire retardant primer on one or both faces, thus decreasing fire reaction. Plywood is less combustible and it is harder to burn. Fire retardant properties are on primed sides only.

Riga 4Ships - birch plywood (Riga Ply) preservative-treated against biological attack and painted with epoxy paint on one or both faces. One face can be with melamine granules, on the reverse face a phenol or melamine film can be applied.

Riga Ship Ply - birch plywood with superior mechanical properties. Internal layers of veneer are of highest quality, produced especially for sea containers designed for liquified gas transportation. Plywood is glued using special water-resistant phenol-formaldehyde glue. Production procedure and product quality are in accordance with requirements set by Gaztrasport & Technigaz, are continuously monitored by one of Certification Institutions - Bureau Veritas, Det Norske Veritas, American Bureau of Shipping or Lloyd's Register.

Riga Ply AT - birch plywood which meets Australian Quarantine and Inspection Service (AQIS) requirements, i.e. wood is protected against insects, including termites. Plywood may have coatings of different kinds, for example Riga Tex AT and Riga Form AT. For glue line treatment Bifenthrin formulation Osmose Detyermite Glue Line Insecticide approved by AQIS is used. The minimum retention of active ingredient 0,013 % mass/mass stated by AQIS is being kept.

Overlaid plywood

Riga Form - birch plywood (Riga Ply) with faces overlaid with one or several layers of phenol-formaldehyde impregnated paper (film) or with films that provide better protection against weathering (grey, blue, opal white). Phenol films are available in different colours (Table 2.1.). The edges of panels are sealed with a paint of same colour as the film on the panel faces.

Riga Mel - birch plywood (Riga Ply) coated with melamine film of white colour on one or both faces. Edges are sealed with white acrylic base paint.

Overlaid plywood with texture

Riga Tex - birch plywood (Riga Ply) with faces overlaid with one or several layers of film, one face smooth and the other one with wire mesh pattern. Two types of mesh are in use, the difference being the density of cells/cm². Dark brown is the most popular colour but other colours are available, too (Table 2.1.). The edges are sealed with a paint of same colour as the film on the panel faces.

Riga Smooth Mesh - birch plywood (Riga Ply) with faces overlaid with phenol film, one face smooth and the other with a dull netted pattern. The films are available in different colours, as well as the edge sealing paint (Table 2.1.).

Riga Rhomb - birch plywood (Riga Ply) with faces overlaid with film, one face smooth and the other one with a rhomboid pattern (see Figure 2.3.). The films are available in dark brown and grey colours, as well as the edge sealing paint. There are also various options for the film's wear resistance.

Riga Heksa, Riga Heksa Plus - birch plywood (Riga Ply) with faces overlaid with film, one face smooth and the other with a special pattern (see Figure 2.3.) The films are available in different colours (dark brown, grey, black, blue and green (only Riga Heksa Plus)), as well as the edge sealing paint. There are also various options for the film's wear resistance.

Riga Foot - birch plywood (Riga Ply) with faces overlaid with film, one face smooth and the other with a special pattern (see Figure 2.3.). The films and the edge sealing paints are available in different colours (dark brown, grey, green and black).

Riga Trans - birch plywood (Riga Ply) with faces overlaid with dark brown phenol film, one face smooth and the other with a special pattern (see Figure 2.3.), produced especially for use as truck and trailer flooring.

Riga Superwire - birch plywood (Riga Ply) with faces overlaid with film, one face smooth and the other with a special pattern (see Figure 2.3.) The films are available in different colours (dark brown, light grey, dark grey, black), as well as the edge sealing paint. There are also various options for the film's wear resistance.

Riga Dot - birch plywood (Riga Ply) with faces overlaid with film, one face smooth and the other with a special pattern (see Figure 2.3.). Pattern gives dot effect. The films are available in different colours (dark brown, light brown, light grey, dark grey, black, yellow, white, opal white), as well as the edge sealing paint. There are also various options for the film's wear resistance.

Riga Frost - birch plywood (Riga Ply) with faces overlaid with film, one face smooth and the other with a special pattern (see Figure 2.3.). Pattern gives mat surface effect. The films are available in different colours (dark brown, light brown, light grey, dark grey, black, yellow, white, opal white), as well as the edge sealing paint. There are also various options for the film's wear resistance.

Riga Deck - birch plywood (Riga Ply) overlaid with a black glass fiber on one face and with a black phenol film on reverse face. The glass fiber face has a special pattern (see Figure 2.3.). The film are available in black colour as well as the edge sealing paint.

Riga Force - birch plywood (Riga Ply) overlaid with a black glass fiber on one face and with a black phenol film on reverse face. The glass fiber face has a special pattern (see Figure 2.3.). The film are available in black colour as well as the edge sealing paint.

Figure 2.3. Types of special pattern

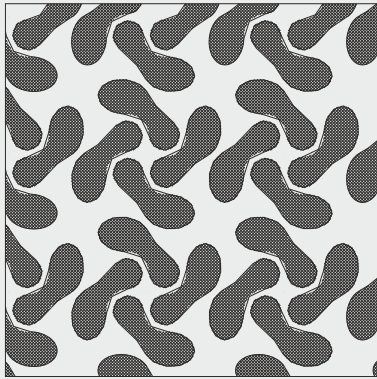

RIGA Foot

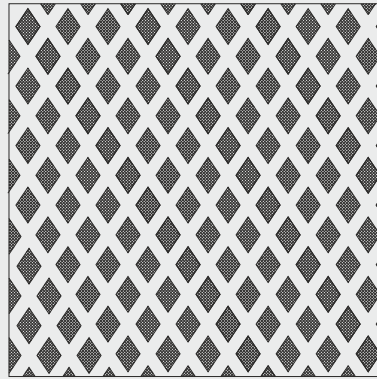

RIGA Rhomb

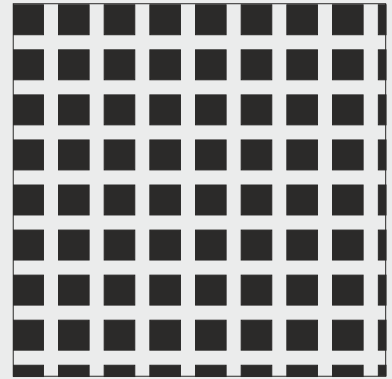

RIGA Trans

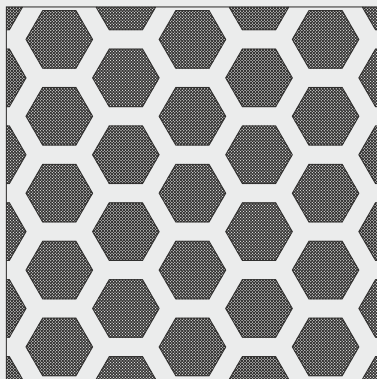

RIGA Heksa

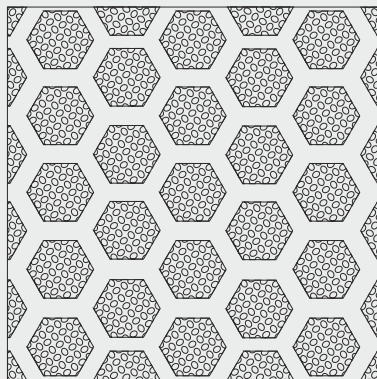

RIGA Heksa Plus

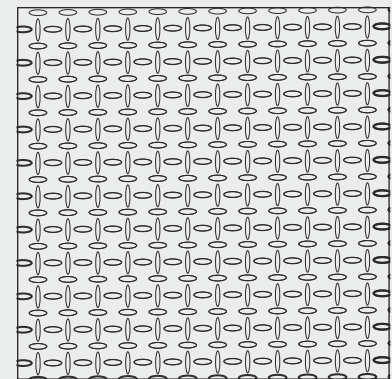

RIGA Force

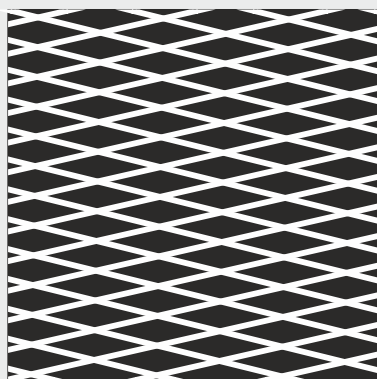

RIGA Deck

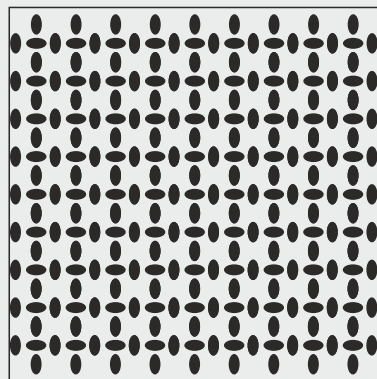

RIGA Superwire

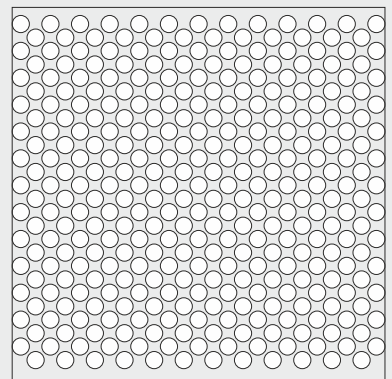

RIGA Dot

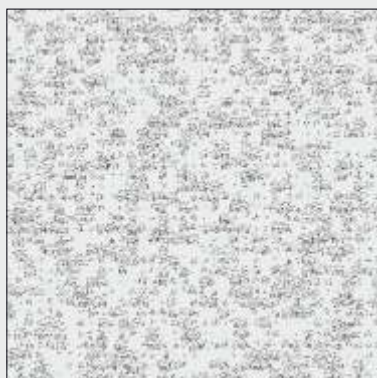

RIGA Frost

Table 2.1. **Characteristics of films**

Film colour	Film weight, g/m ²	Riga Form	Riga Tex	Riga Smooth Mesh
Dark brown	120, 130*, 167, 220	●	●	●
Black	120	●	●	●
Grey	174	●	●	●
Titanium grey	220	●	●	○
Light brown	120	●	●	○
Opal white	174	●	○	○
Blue	225	●	○	●
Yellow	167	●	●	●
Green	120	●	●	●
Red	220	●	●	●
Honey	120	●	○	○

* film with improved wear resistance

Ready-to-paint birch plywood

Riga Paint - birch plywood (Riga Ply) coated with paper designed for priming or painting on one or both faces.

Riga Preprime - birch plywood (Riga Ply) coated with paper impregnated with primer on one or both faces. Plywood with such coating is designed for painting process simplification and paint consumption decrease. Use of epoxy, polyurethane, alkyd or water soluble alkyd based paint is recommended. Edges are sealed with grey alkyde paint.

Riga Prime - birch plywood (Riga Ply or Riga Paint) coated with UV, PU primer on one or both faces. Such a surface finish simplifies future finishing works and decreases finishing material consumption.

Finished plywood

Riga Lacquer - high quality (B, S, BB) birch plywood (Riga Ply) varnished on one or both faces.

Riga Color - birch plywood (Riga Paint or Riga Preprime) painted on one or both faces.

Riga Decor - birch plywood (Riga Ply, grade BB/BB) veneered with various wood species on one or both faces. It can be overlaid with laquer or prime.

Special overlaying and composite construction

Riga HPL - birch plywood (Riga Ply) coated with HPL (High Pressure Laminate) on one or both faces. Balancing material (balance paper) or phenol film may also be applied on the reverse face. HPL is a homogeneous material made from layers of Kraft paper impregnated with phenolic resins (the core) and melamine impregnated decorative paper (the surface layer), manufactured under high pressure and temperature. HPL coating is glued using D2, D3, D4 class glue in accordance with EN 204 requirements.

Riga Silent - birch plywood with 2 or 3 mm cork-rubber composite material used as the core to improve acoustic properties and protection against noise and to damp vibration.

Riga Composite - birch plywood (Riga Ply) where special material(s) is used as overlay(s), and/or inner layer(s) of panels, in order to reach the mechanical and/or appearance properties requested.

Riga Poliform - birch plywood (Riga Ply) overlaid with a special composite material on one or both faces.

2.3. Grades

The quality grade of plywood is defined by type and quantity of visible defects.

Riga Ply grading conditions are in compliance or stricter in comparison with requirements set by the following regulatory documents:

- SFS 2413 Birch Plywood Quality Evaluation by Visual Inspection;
- ISO 139 Recommendations and Conditions Drawn by Work Group II of the Technical Committee (1994);
- EN 635-2 Plywood - Classification by Surface Appearance – Part 2. Hardwood.

Table 2.2. **Grade compliance**

Latvijas Finieris	Grade			
	B	S	BB	WG
SFS 2413	I (B)	II(S)	III(BB)	IV(WG)
ISO 139 recommendations	I	II	III	IV
EN 635-2	I	II	III	IV

Special grade

WGE is WG plywood, where all of splits, knot holes, picks, imprints and holes are repaired.



Table 2.3. Limitations on defects for Riga Ply

Categories of defects	Plywood grades				
	B	S	BB	WG	C
1. Pin knots (Sound intergrown knots $\leq E_1$ 3 mm)	Permitted	Permitted	Permitted	Permitted	Permitted
2. Sound intergrown knots	Permitted $\leq \varnothing 6$ mm, $\Sigma \leq 12$ mm/m ²	Permitted $\leq \varnothing 20$ mm, $\Sigma \leq 50$ mm/m ²	Permitted $\leq \varnothing 25$ mm, $\Sigma \leq 60$ mm/m ²	Permitted $\leq \varnothing 65$ mm, $\Sigma \leq 600$ mm/m ²	Permitted
3. Unsound adhering knots	Not permitted	Not permitted	Not permitted	Permitted $\leq \varnothing 20$ mm, $\Sigma \leq 200$ mm/m ²	Permitted
4. Other knots and holes	Not permitted	Not permitted	Permitted $\leq \varnothing 6$ mm, $\Sigma \leq 25$ mm/m ² , repaired	Permitted $\leq \varnothing 15$ mm, $\Sigma \leq 100$ mm/m ²	Permitted $\leq \varnothing 40$ mm, $\Sigma \leq 10$ m ²
5. Irregularities in the structure of the wood	Permitted, but slight	Permitted	Permitted	Permitted	Permitted
6. Curly grain	Not permitted	Not permitted	Permitted	Permitted	Permitted
7. Open splits and checks	Not permitted	Permitted for an individual width up to 2 mm and of an individual length ≤ 200 mm and ≤ 1 per metre of panel width, repaired	Permitted for an individual width up to 2 mm and of an individual length ≤ 200 mm and ≤ 1 per metre of panel width, repaired	Permitted for an individual width up to 4 mm and ≤ 2 per metre of panel width	Permitted for an individual width up to 10 mm and of an individual length ≤ 400 mm and ≤ 5 per metre of panel width
8. Closed splits and checks	Not permitted	Permitted for an individual length up to 200 mm and in number up to 2 per metre of panel width	Permitted for an individual length up to 200 mm and in number up to 2 per metre of panel width	Permitted	Permitted
9. Discolouration	Permitted, but slight (not at the edges of panel) $\leq 15\%$ of panel surface				
10. Discolouration and coloured streaks	Not permitted	Permitted up to an extent of 15% of the panel surface, some streaks of colour and minerals	Permitted up to an extent of 30% of the panel surface	Permitted	Permitted
11. Brown, but not rot	Not permitted	Not permitted	Permitted up to an extent of 30% of the panel surface	Permitted	Permitted
12. Brown, rot at the initial period	Not permitted	Not permitted	Not permitted	Not permitted	Permitted
13. Inserts	Not permitted	Permitted ≤ 1 m ²	Permitted up to an extent of 3% of the panel surface	Permitted	Permitted

Continuation of Table 2.3.

Categories of defects	Plywood grades				
	B	S	BB	WG	C
14. Open joints	Not permitted	Not permitted	Permitted an individual width up to 2 mm, and of an individual length ≤ 200 mm and ≤ 1 per metre of panel width, repaired	Permitted an individual width up to 3 mm	Permitted an individual width up to 7 mm
15. Imprints and bumps	Not permitted	Not permitted	Permitted, but slight, 2 cm ² per panel	Permitted, but slight	Permitted
16. Roughness	Not permitted	Not permitted	Permitted, but slight (up to 10 cm ² /m ² , repaired) - three defects per panel	Permitted	Permitted
17. Sanding through	Not permitted	Not permitted	Permitted ≤ 10 cm ² /m ²	Permitted ≤ 20 cm ² /m ²	
18. Glue penetration	Not permitted	Occasionally	Permitted up to an extent of 5% of the panel surface	Permitted	Permitted
19. Unsanded areas (for sanded plywood)	Not permitted	Not permitted	Not permitted	Permitted up to an extent of 5% of the panel surface	
20. Defects at the edges due to sanding or trimming	Permitted up to 5 mm from the edge (if the glue is not visible)	Permitted up to 5 mm from the edge, not in all length, repaired	Permitted up to 5 mm from the edge, not in all length, repaired	Permitted up to 5 mm from the edge	Permitted up to 5 mm from the edge
21. Composed face veneers		Permitted, if composed properly, conformable colour	Permitted	Permitted	Permitted
Total number of permitted categories of defects	£3	£6	£9	Unlimited	Unlimited

Table 2.4. Quality requirements for laminated plywood

Defects and requirements	Limitations on defects for grades		
	Grade A	Grade I	Grade II
1. Delamination	Not permitted	Not permitted	Permitted 100 cm ² /m ²
2. Lamination	Laminate shall be clean, smooth and firmly glued to the plywood surface	Laminate shall be clean, smooth and firmly glued to the plywood surface	Laminate shall be firmly glued to the plywood surface on the face side
3. Matt spots on the plywood surface	Permitted on reverse face up to 125 cm ² over the surface or cut out 35 cm ² /m ²	Permitted up to 125 cm ² /m ²	Permitted
4. Scorched laminate as strips and heat stains/spots	Not permitted	Permitted as strips with a width of up to 10 mm (1 pc/width m), allowed as heat stains/spots with a diameter of up to 30 mm (1 pc/m ²) or unlimited if under 10 mm	Unlimited
5. Film overlaps as dark strips	Not permitted	Permitted without any limitations, firmly glued and with a width of up to 20 mm. For Riga Mel, Riga Smooth Mesh not permitted	Permitted
6. Breaks of laminate before pressing	Not permitted	Permitted on the reverse face of the plywood, provided it is carefully covered. For Riga Mel, Riga Smooth Mesh not permitted	Permitted
7. Laminate missing on surface or delamination after pressing	Not permitted	Not permitted	Permitted on a 1/3 of the sheet on the reverse face
8. Glued laminate residues on the surface	Permitted minor (up to 3 pieces) residues on the reverse face, several of a size of up to 1 cm ² in cases where the residues are in the same colour tone as the surface	Permitted with a total area of up to 10 cm ² /m ²	Permitted
9. Imprints if laminate is not damaged	Permitted shallow, minor imprints on the reverse face	Permitted with a total area of 2,5 cm ² /m ² if the width of an imprint does not exceed 5 mm and the sum of the length does not exceed 50 mm/m ²	Permitted
10. Bumps	Permitted minor on the reverse face if laminate is not damaged	Permitted with a total area of 8 cm ² /m ²	Permitted
11. Ridges	Not permitted	Permitted a length of up to 300 mm with a width of up to 10 mm or 1 pc/width m	Permitted
12. Scrapes	Permitted minor scrapes (up to 2) on the reverse face if the laminate is not scraped through	Permitted if the laminate is not scraped through	Permitted
13. Diffuse strips on surface (variations of colour tone or gloss)	Permitted minor strips on the reverse face	Permitted	Permitted
14. Lack of peeled veneer	Not permitted	Permitted for one veneer layer with a width of 3 mm, up to a length of 100 mm. Edges of the plywood shall be firm if the dimensions are standardised	Permitted for one layer with a width of 5 mm along the whole length of the sheet

Continuation of table 2.4.

Defects and requirements	Limitations on defects for grades		
	Grade A	Grade I	Grade II
15. Edge sealing paint on laminated surface	Permitted up to a 3 mm paint overlap on the laminated surface. Paint film on the edges shall be even	Permitted up to a 5 mm paint overlap on the laminated surface. Paint film on the edges shall be even	Permitted
16. Minor rough spots	Permitted minor separate spots with a size of up to 5 cm ² on the reverse face over the surface with a total area of up to 25 cm ²	Permitted up to 125 cm ² over the surface	Permitted
17. Mesh pattern deviations	Not permitted	Not permitted	Permitted
18. Mechanical defects	Not permitted	Not permitted	Permitted
19. Notches	Not permitted	Not permitted	Permitted one with a length of up to 10 cm
20. Pressed in dust visible as small flecks on the surface (Riga Mel)	Not permitted	Permitted	Permitted
Total number of defects	There shall be no defects on face side, no more than 2 categories of defects on the reverse face	No more than 2 categories of defects on face side, no more than 5 categories of defects on the reverse face	Unlimited

2.4. Dimensions and structure

The mechanical properties of wood vary according to the wood grain direction. In order to reach a solid and well-balanced result, plywood is produced by cross-bonding.

Phenol glue is used for gluing together standard plywood veneer layers. It is also possible to use urea-formaldehyde or modified melamine-urea-formaldehyde resin glue. By special additives to glue, some characteristics of plywood can be improved, such as resistance to insects and fire.

Figure 2.4. Plywood lay-up scheme

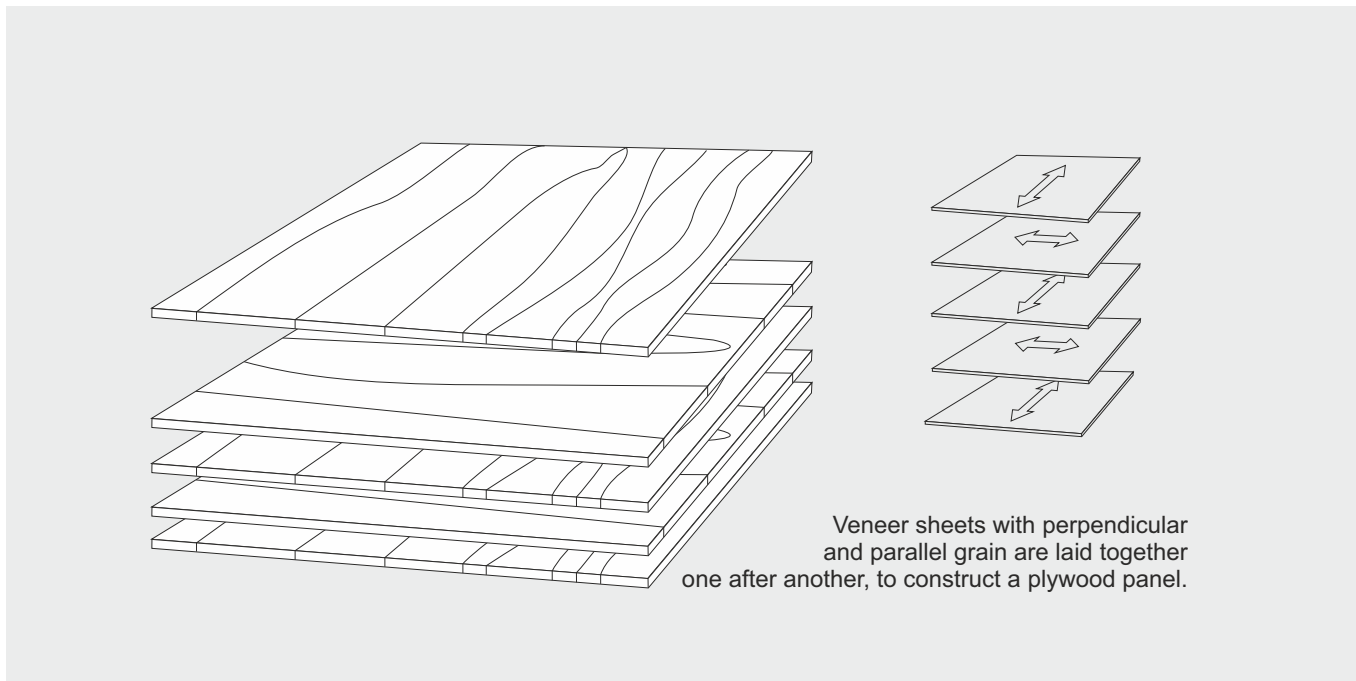

2.4.1. Thickness

Riga Ply thicknesses and thickness tolerances are shown in Table 2.5.

Table 2.5. Nominal thickness

Nominal thickness, mm	4	6.5	9	12	15	18	21	24	27	30	35	40	45	50
Number of veneer layers	3	5	7	9	11	13	15	17	19	21	25	29	32	35
Minimum limit, mm	3.5	6.1	8.8	11.5	14.3	17.1	20.0	22.9	25.8	28.7	33.6	38.4	43.3	48.1
Maximum limit, mm	4.1	6.9	9.5	12.5	15.3	18.1	20.9	23.7	26.8	29.9	35.4	41.2	46.4	51.1
Average actual thickness, mm	3.7	6.3	9.0	11.8	14.6	17.4	20.4	23.2	26.2	28.9	34.5	40.0	44.7	49.5

Thickness tolerances are in accordance with EN 315 requirements. Other panel thicknesses are available on the request.

Table 2.6. Latvijas Finieris plywood products range by nominal thickness

Nominal thickness, mm	4	6.5	9	12	15	18	21	24	27	30	35	40	45	50
Riga Ply	●	●	●	●	●	●	●	●	●	●	●	●	●	●
Riga Form	●	●	●	●	●	●	●	●	●	●	●	●	●	●
Riga Poliform	○	○	●	●	●	●	●	●	○	○	○	○	○	○
Riga Tex	○	●	●	●	●	●	●	●	●	●	●	●	●	●
Riga Smooth Mesh	○	●	●	●	●	●	●	●	●	●	●	●	●	●
Riga Pattern	○	●	●	●	●	●	●	●	●	●	●	●	●	○
Riga Foot	○	●	●	●	●	●	●	●	●	●	●	●	●	○
Riga Heksa	○	●	●	●	●	●	●	●	●	●	●	●	●	○
Riga Heksa Plus	○	●	●	●	●	●	●	●	●	●	●	●	●	●
Riga Rhomb	○	●	●	●	●	●	●	●	●	●	●	●	●	●
Riga Trans	○	○	●	●	●	●	●	●	●	●	●	○	○	○
Riga Paint	○	○	●	●	●	●	●	●	●	●	●	●	●	○
Riga Preprime	○	●	●	●	●	●	●	●	●	●	●	●	●	●
Riga HPL	●	●	●	●	●	●	●	●	●	●	●	●	○	○
Riga Prime	○	●	●	●	●	●	●	●	●	○	○	○	○	○
Riga Lacquer	○	●	●	●	●	●	●	●	○	○	○	○	○	○
Riga Color	○	●	●	●	●	●	●	●	○	○	○	○	○	○
Riga Mel	○	●	●	●	●	●	●	●	●	●	●	●	●	●
Riga Ply AT	○	○	○	○	○	●	●	●	●	●	○	○	○	○
Riga 4Ships	○	●	●	●	●	●	●	●	●	●	●	●	●	●
Riga Prime FR	●	●	●	●	●	●	●	●	●	●	●	●	●	●
Riga Ignisafe	○	○	●	●	●	●	●	●	○	○	○	○	○	○
Riga Crown	○	●	●	●	●	●	●	●	○	○	○	○	○	○
Riga Superwire	○	●	●	●	●	●	●	●	●	●	●	●	●	●
Riga Dot	○	○	○	○	○	●	●	●	●	●	○	○	○	○
Riga Frost	○	●	●	●	●	●	●	●	●	●	●	●	●	●
Riga Deck	●	●	●	●	●	●	●	●	●	●	●	●	●	●
Riga Force	○	○	●	●	●	●	●	●	○	○	○	○	○	○

2.4.2. Birch plywood length and width

Plywood, cross grain, mm

1250 × 2500 / 2750 / 3050 / 3340 / 3660

1525 × 2500 / 2750 / 3050 / 3340 / 3660

2150 × 3050 / 3340 / 3850 / 4000

2290 × 4000

Plywood, long grain, mm

2500 × 1250

2750 × 1525

3000 × 1500

3050 × 2150

3850 × 2150

Dimensions may be different in different product and quality grade groups.

2.4.3. Dimension tolerances

Allowed dimension tolerances are presented in Table 2.7.

Table 2.7. Dimension tolerances

Index	Tolerances
Length, width (mm)	
<1000	1 mm
1000... 2000	2 mm
>2000	3 mm
Right angle	1 mm/1 m
Side edges straightness	1 mm/1 m

Tolerances are in accordance with EN 315 requirements.

2.5. Gluing

2.5.1. Plywood glued using phenol-formaldehyde resin based glue

Such gluing is resistant against environment, weather conditions, microorganisms, cold and hot water, steam and dry hot impact. Phenol-formaldehyde resin based gluing strength characteristics are in accordance with: Class 3 in accordance with EN 314-1 and EN 314-2, BFU 100 Type in accordance with Part 3 of DIN 68705 3, H4 Type (WBP before) in accordance with BS 1203.

2.5.2. Plywood glued with modified melamine-urea-formaldehyde resin based glue

Such gluing is resistant against air humidity during several years. It is resistant against cold water, as well as warm water for a limited time. However it does not pass test of boiling water. The gluing is resistant against cold water, but does not resist microorganisms influence. Plywood glued with this method is designed for indoor applications; it is suitable for further processing with laser cutting tools.

Strength of melamine-urea-formaldehyde resin based gluing is in accordance with:

1 Class in accordance with EN 314-1 and EN 314-2, IW 67 Type in accordance with Part 1 of DIN 68705, and H2 Type (MR before) in accordance with BS 1203.

Indices of gluing strength are daily controlled by laboratories at the production sites. Testing methods, periodicity of control and data statistical processing are in accordance with requirements set by EN 13986. Periodical independent conclusions concerning gluing strength conformity with BFU-100 requirements provide Fraunhofer Wilhelm Klauditz Institut. This gives the enterprise right to mark plywood of phenol-formaldehyde based gluing with BFU-100 register on German market.

2.6. Biological durability

In EN 350-2 is given the guidance on the durability of solid wood to degradation by a range of organisms: wood-destroying fungi, dry wood destroying fungi, termites and marine organisms. In classification of the natural durability to wood-destroying fungi the five class systems are used:

1 – very durable; 2 durable; 3 – moderately durable; 4 - slightly durable; 5 – not durable.

In accordance with EN 350-2 birch wood (*Betula pubescens* Ehrh., *Betula pendula* Roth) stability against fungi influence meets 5th Class of natural durability (not durable).

Plywood biological durability assessment guidance is given in CEN/TS 1099 (see table 2.8). There are taken into account the natural durability for solid timber (EN 350-2) and other factors specific for plywood (CEN/TS 1099 Annex A):

- Wood species;
- Sapwood and heartwood;
- Thickness of plies;
- Adhesive content;
- Preservative treatment.

Table 2.8. **Guidance on the application of natural durability classes of wood species to plywood used in various use classes**

Use class for plywood ^b	Durability class of wood species used in the plies ^a				
	1	2	3	4	5
1	O	O	O	O	O
2	O	O	O	(O)	(O)
3	O	O	(O)	(X)	(X)
4	O	(O)	(X)	X	X
5	O	(X)	(X)	X	X

^a Sapwood of all species is regarded as belonging to durability class 5

^b The use of plywood is only recommended in use class 4 and class 5 if adequately modified (see EN 335-3, Annex and product standards)

Key

- O natural durability sufficient
- (O) natural durability is normally sufficient but, in certain end uses, treatment can be advisable (see EN 460, Annex A)
- (X) preservative treatment is normally advisable but, in certain end uses, natural durability can be sufficient (see EN 460, Annex A)
- X preservative treatment necessary

As plywood produced by Latvijas Finieris is made of ≤1,5 mm thick veneers, durability against various insects, termites and marine organisms shall be assessed as:

- 1) durable against *Hylotrupes bajulus* (D_{Hv}), *Anobium punctatum* (D_A), *Lyctus brunneus* (D_L);
- 2) susceptible to termites (S_t);
- 3) susceptible to marine organisms (S_{Ma}).

The five use classes are defined in EN 335:

- UC 1 – interior, dry;
- UC 2 – interior, or under cover, not exposed to weather. Possibility of water condensation;
- UC 3 – exterior, above ground, exposed to the weather (3.1 – limited wetting conditions; 3.2 – prolonged wetting conditions);
- UC 4 – exterior in ground contact and/or fresh water;
- UC 5 – permanently or regularly submerged in salt water.

Plywood should be selected according to its relevant use classes defined in EN 335 or service classes defined in EN 1995-1 both systems are based on different criteria for classification. The comparison is given in table below (EN 335 Annex A).

Table 2.9. **Service classes and their possible corresponding use classes**

Service class according to EN 1995-1-1	Possible corresponding use class according to EN 335: 2012
Service class 1	Use class 1
Service class 2	Use class 1 Use class 2 if the component is in a situation where it could be subjected to occasional wetting caused by e.g. condensation
Service class 3	Use class 2 Use class 3 or higher if used externally

The guide to the durability requirements for wood and wood-based products to be used in different hazard classes is given in EN 460.

2.7. Emission of free formaldehyde

2.7.1. Formaldehyde. What is it?

At room temperature, formaldehyde is a colourless gas with a pungent odor. It is a fairly simple organic compound composed of carbon, hydrogen and oxygen. Formaldehyde is a naturally occurring organic substance present in foodstuffs and environment, including humans. Formaldehyde is biodegradable; it breaks down in air within a few hours by sunlight or by organisms present in water and soil. Due to its properties formaldehyde is an important chemical used widely by industry to manufacture building materials and numerous household products from cleaners up to medicines and cosmetics.

Formaldehyde is a natural trace element of plant tissues. Hence all wood products emit small amount of formaldehyde.

2.7.2. Why is formaldehyde used for plywood manufacturing?

For a long time formaldehyde has been widely used in production of urea-formaldehyde, phenol and melamine resins. These resins are commonly used in adhesives such as those used in plywood. Based on its chemical reactivity, formaldehyde is an ideal component for adhesives. It forms strong, resistant and cost effective bond. The formaldehyde emissions of modern wood-based panels vary between very small values just above the values of natural wood particles, if bonded with phenol-formaldehyde resins or diisocyanate adhesives, and values in the range of emission class E1 and above, if bonded with urea-formaldehyde resins. The formaldehyde emissions by urea-formaldehyde resins can be reduced through enforcement with melamine.

2.7.3. Emission classes

Europe

Two formaldehyde emission classes determined in Europe according to EN 13986 are presented in Table 2.10.

Table 2.10. **Formaldehyde emission classes according to EN 13986**

Test method	Wood based panels	Class E1	Class E2
EN 717-1 (chamber)	All wood based panels	$\leq 0.124 \text{ mg / m}^3$	$> 0.124 \text{ mg / m}^3$
EN 717-2 (gas analysis)	Uncoated - Plywood - Solid wood panels - LVL Coated, overlaid or veneered - Particleboard - OSB - MDF - Plywood - Solid wood panels - Fibre boards - Cement bonded particleboard - LVL	$\leq 3.5 \text{ mg / m}^2 \text{ h}$	$> 3.5 \text{ mg / m}^2 \text{ h}$ to $\leq 8 \text{ mg / m}^2 \text{ h}$
EN 120 (perforator)	Uncoated - particleboard - OSB - MDF	$\leq 8 \text{ mg / 100 gr oven dry board}$	$> 8 \text{ mg / 100 gr oven dry board}$ to $\leq 30 \text{ mg / 100 gr oven dry board}$

EN 717-1 (chamber test method) is the reference method to test formaldehyde emissions from wood based panels. Testing conditions mainly conform those in which product is used daily, i.e., room temperature. However it is very expensive and time consuming method. Testing of one sample lasts up to 28 days. More common is gas analysis test method EN 717-2, as test can be done in shorter period of time. To test one sample only 6 hours are needed, but also this method needs expensive equipment. Indices of free formaldehyde emission for glued with phenol-formaldehyde resin based glue Riga Ply, Riga Form, Riga Tex, Riga Smooth Mesh plywood are significantly below E1 standard requirements. Emission indices are less than 0.2 ... 0.4 mg HCHO / m² h for conditioned test samples. This is proved by results gained during both long-term self - control in laboratory of the enterprise, and by periodical tests made by independent institutions.

As well, indices of free formaldehyde emission for plywood glued with melamine-urea-formaldehyde and urea-formaldehyde resin based glue are stable and significantly below standard requirements. Emission indices for these products are less than 0.5...1.0 mg HCHO / m² h for conditioned test samples.

Japan

Four formaldehyde emission classes determined in Japan are presented in Table 2.11.

Table 2.11. **Formaldehyde emission classes in Japan**

Class	Test method	
	JIS A 1460, mg/l	JIS A 1901, mg/m ² h
F****	< 0.3	< 0.005
F***	0.3 ... 0.5	0.005 ... 0.02
F**	0.5 ... 1.5	0.02 ... 0.12
F*	1.5 ... 5.0	< 0.12

California

The California Air Resources Board (CARB) conducts a Rulemaking process to address formaldehyde exposure from composite wood products. On April 26, 2007 CARB approved an Airborne Toxic Control Measure (ATCM) to reduce formaldehyde emissions from composite wood products including hardwood plywood, particleboard, medium density fiberboard, thin medium density fiberboard (thickness ≤ 8mm), and also furniture and other finished products made with composite wood products.

According to California Code of Regulations § 93120.2 (a) Table 2.12. the following formaldehyde emission requirements from composite wood products are determined:

Table 2.12. **Formaldehyde emission requirements according to CARB**

Phase 1 and Phase 2 Formaldehyde Emission Standards for Hardwood Plywood (HWPW), Particleboard (PB), and Medium Density Fiberboard (MDF)¹

Effective Date	Phase 1(P1) and Phase 2 (P2) Emission Standards (ppm)				
	HWPW-VC	HWPW-CC	PB	MDF	Thin MDF
1-1-2009	P1: 0.08	-----	P1: 0.18	P1: 0.21	P1: 0.21
7-1-2009	-----	P1: 0.08	-----	-----	-----
1-1-2010	P2: 0.05	-----	-----	-----	-----
1-1-2011	-----	-----	P2: 0.09	P2: 0.11	-----
1-1-2012	-----	-----	-----	-----	P2: 0.13
7-1-2012	-----	P2: 0.05	-----	-----	-----

¹ Based on the primary test method [ASTM E 1333-96(2002)] in parts per million (ppm).
HWPW-VC = veneer core; HWPW-CC = composite core

Emissions data obtained by using different testing methods cannot be compared with each other, because each standard describes different requirements for sample preparing and testing procedure, including climatic conditions. Determination of correlation among the formaldehyde release values by different test methods (eg., EN, JIS, JAS, ISO, ASTM) is the aim of different scientific research projects.

2.7.4. Conformity certificates

Latvijas Finieris regularly tests emission of free formaldehyde in the laboratories during plywood production according to EN 717-2 in order to provide compliance to formaldehyde emission requirements. Product or packaging is marked with E1 or it is indicated in commercial documents. Latvijas Finieris has concluded E1 and CARB surveillance agreements with competent institutions regarding formaldehyde emission certification. As result of this several times a year representatives of independent institution inspect production process, mill's quality control system, select testing samples and test them. Thus buyers upon request can receive conformity documents – certificates and testing reports, issued by independent institution.

Phenolic glued plywood manufactured by Latvijas Finieris conforms to formaldehyde emission standards of CARB Phase 2.

According to the California Air Resources Board (CARB) Executive Order N-12-124 Riga© phenolic glued birch plywood manufactured at mill Lignum is approved as a product with ultra-low-formaldehyde-emission resins. This approval demonstrates that free formaldehyde emission from the certified products is constantly and significantly below the CARB Phase 2 and IKEA quality standards requirements.

Plywood Riga Ply glued with phenol-formaldehyde resin based glue is certified according to Japanese 4-Star Regulations. 4-star certificate is issued by Japan Ministry of Land, infrastructure, Transport and Tourism.

2.8. Content of pentachlorophenol (PCP)

European standard EN 13986 sets that content of pentachlorophenol in wood shall be below 5 ppm (1 ppm = 1 mg/kg). Chemical substances containing PCP are not used for plywood production procedure. However this characteristic is under control to assure product harmlessness for consumer health. Having made testing the independent institution concluded that PCP content is below minimum limit of measurement range or less than 0.1 ppm.

PCP content is defined according to national testing methods. Standard European testing methods CEN TC 38 are under development at the moment.

2.9. Moisture content

Plywood average moisture content after production is from 6% to 10% according to EN 322 Wood-based panels - Determination of moisture content. Due to the fact that wood is a hygroscopic material, the level of plywood moisture content directly depends on ambient temperature and air relative humidity. The level of moisture content may vary during transportation and storage.

While storage at ambient temperature of 20°C and relative humidity of 65%, the plywood moisture content is of $9 \pm 3\%$.

Moisture content change will result in plywood dimension variations (for details see Chapter 6.1.3).

2.10. Density

Wood density depends on several factors, for example, timber growing conditions, sapwood or core wood, etc. Plywood density is at least 15% higher than the density of the wood raw material used for it.

Plywood density depends not only on the density of wood used for production but also on pressing level, moisture content, and other factors.

Density of birch plywood produced by Latvijas Finieris is within the limits from 670 kg/m³ to 750 kg/m³ at air temperature of 20 °C and relative humidity of 65% according to EN 323 Wood-based panels - Determination of density.

2.11. Production control

Latvijas Finieris ensures and guarantees a stable quality of its products and services, improves the competitiveness of the products by precisely defining the production processes, including testing, control and inspection systems.

There are laboratories at each mill, their task is to observe the production processes, product quality and to develop new products and technology. Laboratories are equipped with sophisticated technical equipment for inspection of production processes and testing physical-mechanical properties of product.

Type, performance and frequency of the factory production control correspond to the requirements of standards EN 13986 and EN 326-2.

Conformity assessment of factory production control was performed, and certificate was issued by Fraunhofer Wilhelm Klauwitz Intitute, EU notification 0765.

Plywood Riga Ply bonding quality data (2006-2007) according to factory production control are presented in Table 2.13. Test was done according to EN 314-1.



▲ **Figure 2.5. In order to guarantee stable quality, the plywood products pass everyday tests in mills laboratories**

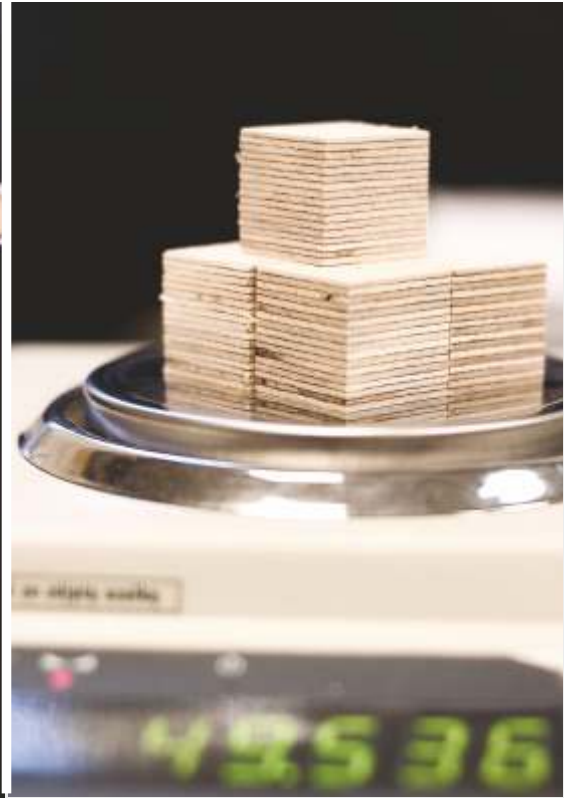

▲ **Figure 2.6. Weighing of plywood samples, to determine their moisture content and density**

Riga Ply (sanded) bending strength and stiffness (modulus of elasticity) values (till 2012) correspond to lower 5 quantile and average values determined according to EN 310 test method and calculated according to EN 326-1, plywood moisture content $8 \pm 2\%$ are presented in Table 2.14 and 2.15. The mechanical characteristics of plywood produced in Sastamala, Finland, correspond to the parameters indicated in The Handbook of Finnish Plywood.



Table 2.13. Plywood Riga Ply bonding quality according to factory production controls

Pretreatments according to EN 314-1	Average failing force, N/mm ²	Lower 5% quantile, N/mm ²	Average cohesive wood failure percentage
Immersion for 24 h in water at $20 \pm 3^{\circ}\text{C}$	2.53	1.81	59.1
Immersion for 4 h in boiling water, then drying in the ventilated drying oven for 16 to 20 hours at $60 \pm 3^{\circ}\text{C}$, then immersion in boiling water for 4 hours, followed by cooling in water at $20 \pm 3^{\circ}\text{C}$ for at least 1 h	2.07	1.47	60.4
Immersion for 72 ± 1 h in boiling water, followed by cooling in water at $20 \pm 3^{\circ}\text{C}$ for at least 1 h	1.92	1.32	66.4

Table 2.14. Plywood Riga Ply lower 5% quantile values of bending strength and stiffness according to factory production controls

Nominal thickness, mm	Along the grain				Perpendicular the grain			
	Strength		Modulus of elasticity		Strength		Modulus of elasticity	
	N/mm ²	Class	N/mm ²	Class	N/mm ²	Class	N/mm ²	Class
4	85.2	F 50	10486	E 100	23.8	F 15	1052	E 10
6.5	80.1	F 50	8831	E 90	42.9	F 25	2873	E 30
9	74.4	F 40	8323	E 90	54.7	F 35	4446	E 40
12	70.6	F 40	7886	E 80	53.0	F 35	4782	E 50
15	66.5	F 40	7776	E 80	53.4	F 35	5400	E 60
18	61.7	F 40	7423	E 80	52.0	F 35	5566	E 60
21	59.8	F 35	7219	E 80	50.1	F 30	5876	E 60
24	58.7	F 35	7420	E 80	51.5	F 30	5767	E 60
27	55.9	F 35	7306	E 80	55.1	F 35	6184	E 60
30	58.7	F 35	7440	E 80	51.9	F 30	6222	E 60
35	58.4	F 35	6900	E 70	53.0	F 35	6242	E 60
40	55.1	F 35	6948	E 70	54.8	F 35	6292	E 60
45	57.0	F 35	7004	E 70	50.0	F 30	6652	E 60
50	54.1	F 35	7021	E 70	48.5	F 30	5407	E 60

Table 2.15. Plywood Riga Ply average values of bending strength and stiffness according to factory production controls

Nominal thickness, mm	Along the grain		Perpendicular the grain	
	Strength	Modulus of elasticity	Strength	Modulus of elasticity
	N/mm ²	N/mm ²	N/mm ²	N/mm ²
4	123.1	13808	30.6	1531
6.5	102.2	10920	56.5	4169
9	93.6	10116	69.1	5869
12	89.4	9854	69.9	6364
15	84.1	9532	70.1	6806
18	77.7	8993	68.1	6898
21	70.7	8424	67.0	7065
24	71.0	8577	65.1	7081
27	65.8	8227	65.8	7265
30	68.1	8439	61.3	6882
35	64.9	7800	67.1	7372
40	63.1	7885	63.6	7452
45	64.9	7974	62.2	7435
50	63.0	8130	59.8	7179

2.12. Screw withdrawal force

Screw withdrawal force is determined according to standard EN 320 Fiberboards – determination of resistance to axial withdrawal of screws. Screws with diameter 4.2 mm are screwed in plywood in predrilled holes (2.7 mm diameter and 19 mm depth). If plywood is thinner than 15 mm the screw is screwed so that its conic part of tread protrudes plywood. Screw withdrawal force is the force that is necessary to withdraw a screw from plywood sample. The force to withdraw screws from plywood is determined by both face and edge (Table 2.16.).

Table 2.16. Mean Riga Ply screw withdrawal force, kg

Nominal thickness, mm	Edge	Face
4	210	60
6.5	210	135
9	210	175
12	210	240
15...50	210	285



characteristics of products

statistical processing of data	3-1
wear resistance of overlaid plywood	3-2
the effect of loaded heavy duty castors	
on overlaid plywood	3-4
reaction to fire	3-5
friction	3-8
chemical stability of overlaid plywood	3-10

3.1. Statistical processing of data

Indices of plywood strength can depend on numerous factors, for example, veneer log sort, lay-up scheme, moisture content, plywood finishing (sanded or unsanded), etc. To establish plywood characteristics it is necessary to test a large number of samples. The larger is the number of tested samples, the more reliable testing results obtained.

In calculations, various methods of statistical data processing are used, such as arithmetic mean, standard deviation, coefficient variation, etc.

Separate arithmetic mean (mean value) describes (reflects) average value of characteristic in question.

Standard deviation describes dispersion in respect of arithmetic mean. The smaller is standard deviation, the smaller is data dispersion relatively to arithmetic mean.

Percentile or quantile are 1/100 parts of ranged data series. Methodical instructions on quantile calculation are provided by EN 326-1.

Having standard deviation(s) and arithmetic mean (x_{avg}), it is possible to calculate probability that the data (index, characteristic) are within interval $x_{avg} \pm s$; $x_{avg} \pm 2s$; $x_{avg} \pm 3s$. If database is of normal distribution, probabilities are:

within interval $x_{avg} - s$ to $x_{avg} + s$ - 68,3% of data;

within interval $x_{avg} - 2s$ to $x_{avg} + 2s$ - 95,5% of data;

within interval $x_{avg} - 3s$ to $x_{avg} + 3s$ - 99,7% of data.

Figure 3.1. Normal distribution of data

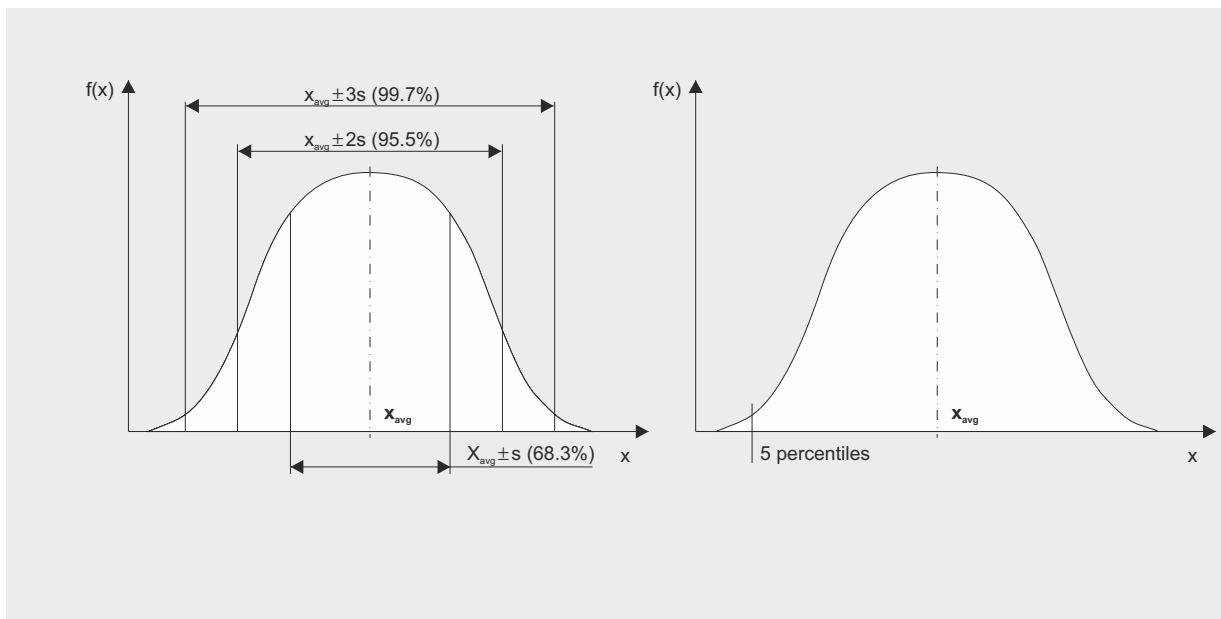

3.2. Wear resistance of overlaid plywood

The method of determination of overlays' wear resistance is described by EN 438 Decorative high-pressure laminates (HPL) - Sheets based on thermosetting resins - Part 2: Determination of properties. Loaded rollers act on rotating sample; the rollers are coated with sanding paper, simulating actual operation loads. Wear degree is evaluated visually and the result is expressed in revolutions (Taber value). Wear resistance varies according to testing conditions, such as ambient temperature and relative moisture content. Therefore it is more relevant to provide a resistance class, instead of definite values. Wear resistance classes of plywood products manufactured by Latvijas Finieris are presented in Table 3.1. Tables 3.2. - 3.5. provide wear resistance classes of various plywood coatings.

Figure 3.2. Wear resistance of Riga Form plywood

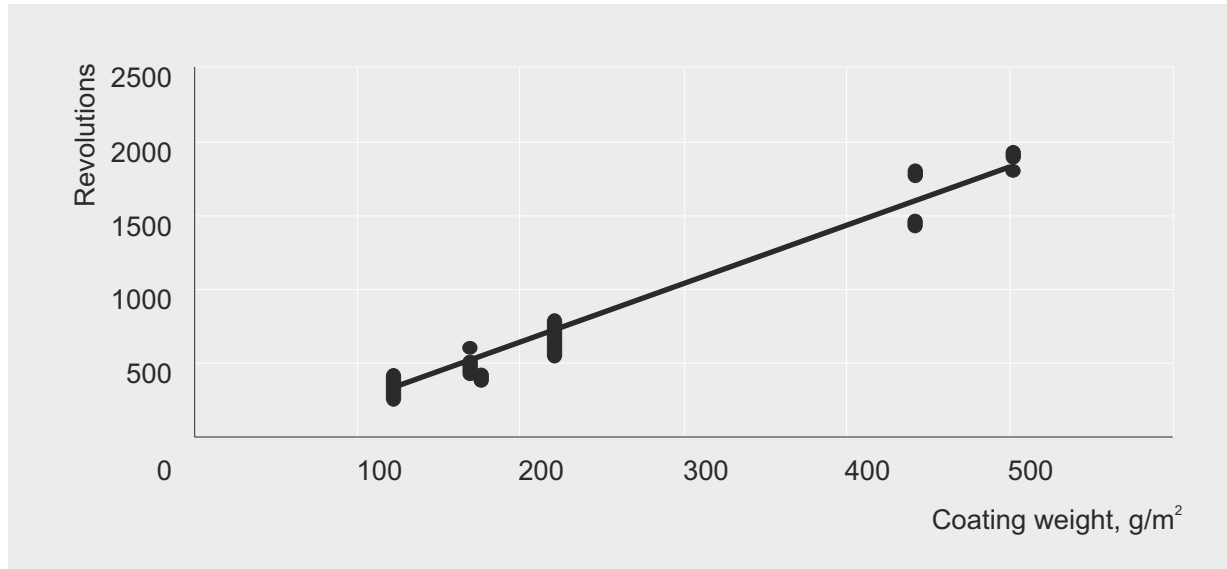

Table 3.1. Wear resistance classes of overlaid plywood products

Class	1	2	3	4	5	6	7	8	9	10	11
From revolutions	0	26	100	250	400	600	900	1500	2500	5000	10000
To revolutions	25	99	249	399	599	899	1499	2499	4999	9999	...

To increase plywood overlay wear resistance it is possible to apply overlays of several film layers or from special films of improved wear resistance. For all overlaid products it is possible to determine overlay wear resistance, wear resistance of pattern, and upper layer wear resistance (in cases where the overlay consists of several film layers eg. of different colours).

Table 3.2. Wear resistance classes of overlaid products

Film weight, g/m ²	Number of coating layers, pcs.	Total weight, g/m ²	Riga Form	Riga Tex, Small mesh	Riga Tex, Large mesh	Riga Smooth Mesh, Small mesh	Riga Smooth Mesh, Large mesh
120	1	120	4	4	4	4	4
167	1	167	5	5	5	5	4
174	1	174	5	5	5	5	4
220	1	220	6	6	5	6	5
174	2	348	7		7		7
220	2	440	8	8	8		
174	3	522	8		8		
220	3	660		9	9	8	8
220	4	880			9	9	9

Table 3.3. **Wear resistance classes of overlays with improved wear resistance films**

Product	Overlay weight, g/m ²			
	130	260	350	390
Riga Form	9			
Riga Tex, Small mesh	9		10	
Riga Tex, Large mesh	9	11	10	11

Table 3.4. **Wear resistance classes of special pattern products**

Product	Overlay colour	Wear resistance class
Riga Foot	Grey	7
	Dark brown, green	6
Riga Foot Heavy	Dark brown	11
Riga Heksa	Dark brown, grey, black	8
Riga Heksa Heavy	Dark brown	11
Riga Rhomb	Dark brown	6
	Grey	7
Riga Rhomb Heavy	Dark brown	10
Riga Pattern	Dark brown	6
	Grey, green, black	7
Riga Pattern Heavy	Dark brown	11
Riga Heksa Plus	Dark brown	5
	Grey	7
	Green	6
Riga Heksa Plus Heavy	Dark brown	10
Riga Trans	Dark brown	7
Riga Trans Heavy	Dark brown	9

Table 3.5. **Wear resistance classes of products with melamine film overlay**

Product	Overlay colour	Wear resistance class
Riga Mel	White	5

3.3. The effect of loaded heavy duty castors on overlaid plywood

Testing method described by EN 1818 Resilient floor coverings - Determination of the effect of loaded heavy duty castors is used to test the effect of loaded swivel castor on overlaid plywood. The aim of this Rolling test is to simulate the effect caused by loaded swivel castor on plywood overlay material (laminated). Testing device is shown on Figure 3.3.

Overlaid material is trafficked by 300 kg loaded swivel castor (a width of the castor 40 +/- 1 mm and diameter 115 +/- 5 mm). The castor moves backwards and forwards until plywood overlay is damaged. Splits and cracking appear on the overlay surface. Results are registered as number of cycles till occurrence of damage in the material. Results are shown in Table 3.6 and 3.7.

Figure 3.3. **Determination of the effect of loaded heavy duty castors**

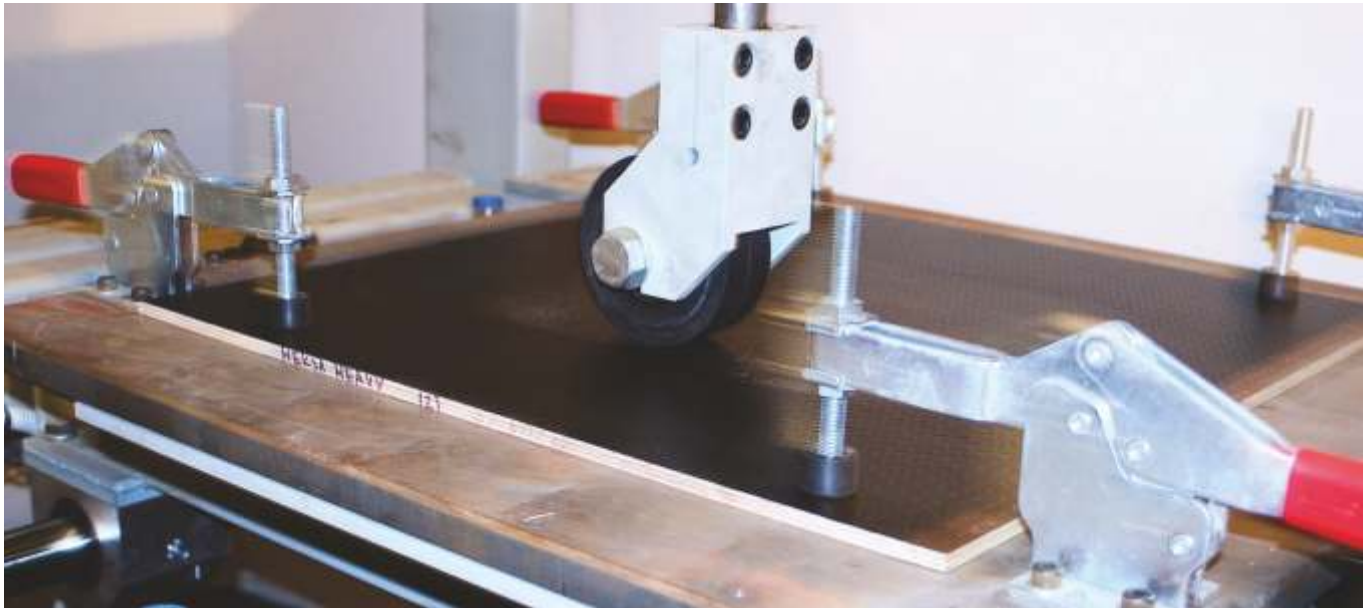

Table 3.6. **Resistance of overlaid plywood**

Product	Number of cycles
Riga Rhomb	> 10000
Riga Foot	> 2000
Riga Heksa	> 10000
Riga Heksa Plus	> 10000
Riga Trans	> 6000
Riga Pattern	> 2000

Table 3.7. **Resistance of Riga Tex**

Film weight, g/m ²	Type of mesh	Number of cycles
120	Small	> 6000
130	Small	> 9000
167	Small	> 7000
220	Small	> 8000

3.4. Reaction to fire

Classification of reaction to fire performance for plywood (EN 636) according to European communities decision of 15 May 2007 (2007/348/EC) presented in Table 3.8.



Table 3.8. Classes of reaction to fire performance for plywood

End use conditions (6)	Minimum density, kg/m ³	Minimum thickness, mm	Class (7) (excluding flooring)	Class (8) (flooring)
without an air gap behind the panel (1), (2), (5)	400	9	D-s2, d0	Dfl-s1
with a closed or an open air gap not more than 22 mm behind the panel (3), (5)	400	9	D-s2, d2	-
with a closed air gap behind the panel (4), (5)	400	15	D-s2, d1	Dfl-s1
with an open air gap behind the panel (4), (5)	400	18	D-s2, d0	Dfl-s1
any (5)	400	3	E	Efl

- (1) Mounted without an air gap directly against class A1 or A2-s1, d0 products with minimum density 10 kg/m³ or at least class D-s2, d2 products with minimum density 400 kg/m³.
- (2) A substrate of cellulose insulation material of at least class E may be included if mounted directly against the wood-based panel, but not for floorings.
- (3) Mounted with an air gap behind. The reverse face of the cavity shall be at least class A2-s1, d0 products with minimum density 10 kg/m³.
- (4) Mounted with an air gap behind. The reverse face of the cavity shall be at least class D-s2, d2 products with minimum density 400 kg/m³.
- (5) Veneered, phenol- and melamine-faced panels are included for class excl. floorings.
- (6) A vapour barrier with a thickness up to 0,4 mm and a mass up to 200 g/m² can be mounted in between the wood-based panel and a substrate if there are no air gaps in between.
- (7) Class as provided for in Table 1 of the Annex to Decision 2000/147/EC.
- (8) Class as provided for in Table 2 of the Annex to Decision 2000/147/EC.

Classification of reaction to fire performance for raw, overlaid, veneered or coated plywood according to EN 13986:2004 presented in Table 3.9.

Table 3.9. Classes of reaction to fire performance for plywood according to EN 13986:2004

Minimum density, kg/m ³	Minimum thickness, mm	Class ¹ (excluding flooring)	Class ² (flooring)
400	9	D-s2, d0	D _f -s1

The classes given in this table are for unjointed panels, T&G jointed panels installed according to ENV 12872 and fully supported joints installed according to ENV 12872. Plywood mounted without an air gap directly against class A1 or A2-s1, d0 product with minimum density 10 kg/m³ or at least class D-s2, d0 products with minimum density 400 kg/m³.

- (1) – Class as provided for in Table 1 the Annex to Decision 2000/147/EC.
- (2) – Class as provided for in Table 2 the Annex to Decision 2000/147/EC.

The reaction to fire performance shall be tested and classified according to EN 13501-1 or the classes can be based on Table 3.8 or 3.9.

Panel mounting and fixing method considerably affects the conformity to the classification. When testing, and if required by test method, the product shall be mounted and fixed as for its intended end use.

Classification of different products (trade marks) produced by Latvijas Finieris is presented in the Table 3.10.

Table 3.10. **Classes of reaction to fire for plywood according to EN 13501-1**

Product	Thickness, mm	End use conditions	Class (excluding flooring)	Class (flooring)
Riga Ply	4	Without an air gap behind directly against class D-s2, d0 products	E	
Riga Ply	6.5		D-s2, d2	
Riga Ply	12	Without an air gap behind directly against class A1 products	D-s1, d2	
Riga Ply	35		D-s1, d0	
Riga Form	12		D-s1, d2	
Riga Form	35		D-s1, d0	
Riga Form, opal white	9		D-s1, d0	
Riga Smooth Mesh, grey	18		D-s1, d0	
Riga Mel	12		D-s1, d2	
Riga Lacquer, LC	9		D-s1, d0	
Riga Prime FR	12		B-s1, d0	Bfl-s1
Riga HPL, white/BL	9		D-s1, d0	
Riga Heksa Plus, grey/white melamine	21			Bfl-s1

3.4.1. Other fire safety requirements

Since 2005 Latvijas Finieris holds a certificate of Italian Ministry of Interior, confirming that Riga Tex meets Class 1 requirements for fire safety according to UNI 9177 classification. This certificate is often required when building eg. stages, pedestrian bridges, walkways, platforms and ship decks.

The product Riga Form F/BB with thickness 15 mm complies with the requirements for the materials belonging to the category Floors according to UNI CEI 11170-3 Ed.2005 + FA 2007- Chapter 6, Prospect 1 Acceptance criteria for materials and components of equipment, all hazard levels until LR4 included.

According to European Directive 95/28/EEC the products Riga Ply, Riga Form, Riga Tex, Riga Heksa, Riga Rhomb, Riga Foot, Riga Pattern, Riga Trans, Riga Heksa Plus have the EC Type- Approval Certificate for motor vehicles of category M3. The material is suitable for installation:

- as roofing material,
- as rear or side wall lining,
- as floor covering,
- as luggage rack.

The certificate is valid for above mentioned products without phenol film or with phenol film on one or both faces and for thickness between 6.5 mm and 35 mm. The materials could be marked as follows:

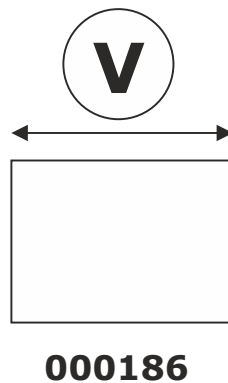

Riga Ply (thickness 5 mm) and Riga Tex (12 mm) meet fire requirements S4.3 according to FMVSS 302. Burn rate is below 102 mm/min. Flaming stops in 50 seconds from the start and burn is not more than 1 mm.

3.5. Friction

The friction tests (anti slip properties) is determinate according to DIN 51131 method. The test platform 5 kg is pulled on the sample within the 800 mm paths, under the platform three SBR rubbers with dimensions 10x25mm and hardness 49±2 according to Shore hardness scale are glued, the force resisting the motion is recorded. Results are determinated as dynamic friction force and coefficient of friction. The dynamic friction force and coefficient of friction are calculated as an average force and coefficient within the testing (measurement) path (from 200 – 700 mm).

Birch plywood covered with 10W30 oil friction values are shown in Table 3.11.

Table 3.11. Friction of overlaid plywood

Product	Coefficient of friction	Dynamic friction force, N/mm ²
Riga Form	0.28	14.0
Riga Foot	0.17	8.5
Riga Heksa	0.32	15.9
Riga Heksa Plus	0.37	18.0
Riga Pattern	0.40	19.6
Riga Rhomb	0.34	16.6
Riga Trans	0.16	8.0
Riga Trans Heavy	0.24	11.8
Riga Tex WF 120	0.29	14.4
Riga Tex WF 220	0.75	36.6
Riga Tex WL -F 120	0.32	15.9
Riga Tex WL -F 220	0.43	21.2

Correlation between DIN 51130 and ramp test acceptance angle is shown on Figure 3.4.

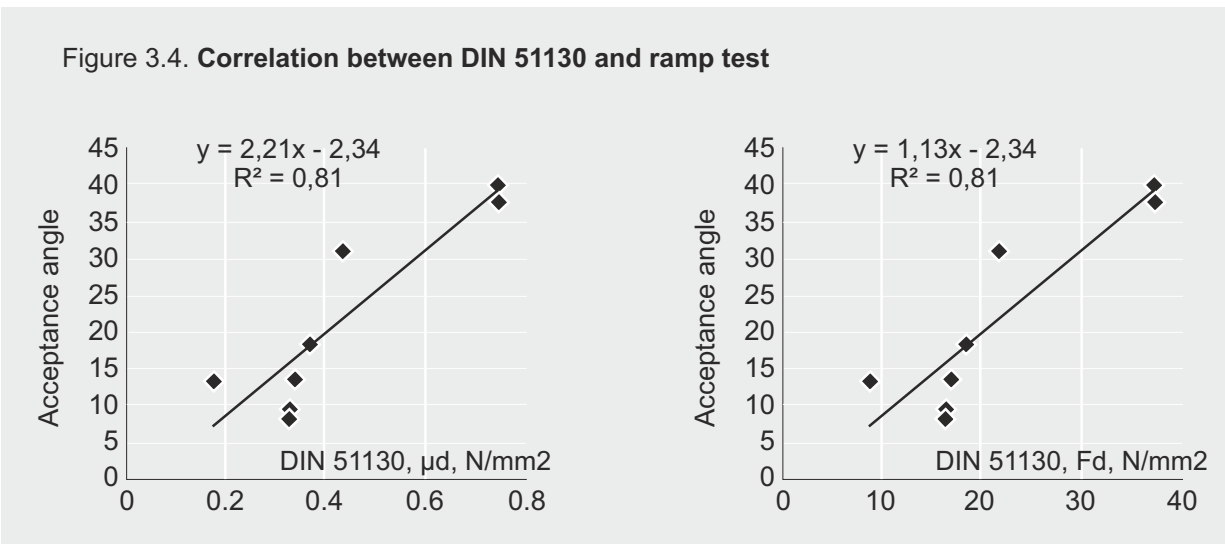

Latvijas Finieris does not publish any general uncommented sliding friction coefficients. The sliding friction coefficient of a friction-increasing surface depends on the combination of materials involved, the temperature, the condition of the material surfaces and the anti-slip mat (soiling, moisture, etc.). The contact surfaces of load and floor must be swept clean, grease-free and dry to achieve optimum anti-slip properties.

Anti-slipping property flooring surfaces capability of preventing slipping. This is determined in accordance with BGR 181 (bisher ZH1/571) and DIN 51130. In accordance with this method the anti-slipping property is described as angle at which a person is slipping when moving forward and back over the tested surface. The tested material and footwear sole are slightly oiled with 10W30 oil. The anti-slipping group is defined according to the average accepted angle.

Table 3.12. Anti-slipping property evaluation groups

Average acceptance angle	Anti-slipping property evaluation group
From 10° to 19°	R 10
From 19° to 27°	R 11
From 27° to 35°	R 12
Above 35°	R 13

Table 3.13. Anti-slipping property evaluation

Product	Anti-slipping property evaluation group
Riga Foot	R 10
Riga Tex	R 13
Riga Pattern	R 9
Riga Heksa	R 9
Riga Heksa Plus	R 10
Riga Trans	R 13
Riga Trans Heavy	R 13
Riga Rhomb	R 10
Riga Smooth Mesh	R 9
Riga 4Ships	R 11

3.6. Chemical stability of overlaid plywood

Tests are made in accordance with EN 438-2 Decorative high-pressure laminates – Sheets based on thermosetting resins – Part 2: Determination of properties (ISO 4586 – 2:1988 Modified).

The following reagents are used for testing: acetone, coffee, sodium hydroxide (25%), hydrogen peroxide (30%), shoe polish, and citric acid (10%). The results are presented in Table 3.14.

The following finished and overlaid plywood are tested: Riga Tex, Riga HPL, Riga Decor, Riga Prime, Riga Lacquer, Riga Color, Riga Form. Each reagent is kept in contact with sample surface within 24 hours.

Grades of surface stability tests are as follows:

Grade 5: no visible alterations.

Grade 4: minor gloss / colour alterations visible at certain angle of view.

Grade 3: moderate gloss or colour alterations.

Grade 2: significant gloss and / or colour alterations.

Grade 1: damages of surface and / or bubbling.

Table 3.14. Results of chemical stability tests

Product	Agent						
	Acetone, grade	Coffee, grade	Sodium hydroxide (25%), grade	Hydrogen peroxide (30%), grade	Shoe polish, grade	Citric acid (10%), grade	Red wine, grade
Riga Form	4	5	2	5	2	5	5
Riga Tex	5	5	2	4	2	5	5
Riga Prime	5	5	1	5	1	5	5
Riga Mel	4	5	4	4	3	5	5
Riga HPL	4	5	5	5	1	5	5

EN 13986 standard allows to indicate some specific plywood properties without testing, using tables published in the standard. The following properties are attributed to plywood in accordance with these tables (see Table 3.15):

Table 3.15. Properties of plywood in accordance with EN 13986

Properties	Standard	Unit	Value or class													
			4	6.5	9	12	15	18	21	24	27	30	35	40	45	50
Nominal thickness		mm	4	6.5	9	12	15	18	21	24	27	30	35	40	45	50
Density	EN 323	kg/m ³	650 - 750													
Surface weight	EN 315	kg/m ²	2.8	4.6	6.3	8.4	10.5	12.6	14.7	16.8	18.9	21	24.5	28	31.5	35
Reaction to fire	EN 13986	Class	-	D-s2, d0 / D _{FL} -s1												
Steam permeability	EN 13986 Wet cup μ		90													
	EN 13986 Dry cup μ		220													
Air sound isolation	EN 13986	dB	-	24.4	26.0	27.3	28.3	29.2	29.9	30.6	31.2	32.1	32.8	33.5	34.1	
Sound absorption From 250 Hz to 500 Hz From 1000 Hz to 2000 Hz	EN 13986	coefficient	0.10													
			0.30													
Thermal conductivity	EN 13986	W/(m*K)	0.17													



mechanical
properties

Characteristic strength and stiffness

The strength and stiffness values of Riga Ply birch plywood are given in Tables 4.1 to 4.21. These values correspond to VTT research protocol RTE-3367-04.

These values can be used in design according to Eurocode 5 - Design of timber structures - Part 1:1 General rules and rules for buildings.

The mechanical characteristics of plywood produced in Sastamala, Finland, correspond to the parameters indicated in The Handbook of Finnish Plywood.

Table 4.1. Thickness t , area A , section modulus W and second moment of area I of birch plywood Riga Ply

Nominal thickness and number of veneers	Unsanded				Sanded			
	t , mm	A , mm ²	W , mm ³	I , mm ⁴	t , mm	A , mm ²	W , mm ³	I , mm ⁴
4/3	4.20	4.20	2.94	6.17	3.60	3.60	2.16	3.89
6.5/5	7.00	7.00	8.17	28.6	6.40	6.40	6.83	21.8
9/7	9.80	9.80	16.0	78.4	9.20	9.20	14.1	64.9
12/9	12.6	12.6	26.5	167	12.0	12.0	24.0	144
15/11	15.4	15.4	39.5	304	14.8	14.8	36.5	270
18/13	18.2	18.2	55.2	502	17.6	17.6	51.6	454
21/15	21.0	21.0	73.5	772	20.4	20.4	69.4	707
24/17	23.8	23.8	94.4	1123	23.2	23.2	89.7	1041
27/19	26.6	26.6	118	1568	26.0	26.0	113	1465
30/21	29.4	29.4	144	2118	28.8	28.8	138	1991
35/25	35.0	35.0	204	3573	34.4	34.4	197	3392
40/29	40.6	40.6	275	5577	40.0	40.0	267	5333
45/32	44.8	44.8	335	7493	44.2	44.2	326	7196
50/35	49.0	49.0	400	9804	48.4	48.4	390	9448

Table 4.2. Ratios A/A_{eff} , W/W_{eff} , and I/I_{eff} of unsanded birch plywood Riga Ply

Nominal thickness and number of veneers	Along the grain direction of the face veneers			Across the grain direction of the face veneers		
	A/A_{eff}	W/W_{eff}	I/I_{eff}	A/A_{eff}	W/W_{eff}	I/I_{eff}
4/3	1.500	1.038	1.038	3.000	9.001	27.000
6.5/5	1.667	1.263	1.263	2.500	2.885	4.808
9/7	1.750	1.406	1.406	2.333	2.475	3.465
12/9	1.800	1.503	1.503	2.250	2.324	2.988
15/11	1.833	1.573	1.573	2.200	2.245	2.744
18/13	1.857	1.626	1.626	2.167	2.197	2.597
21/15	1.875	1.667	1.667	2.143	2.165	2.498
24/17	1.889	1.701	1.701	2.125	2.142	2.427
27/19	1.900	1.728	1.728	2.111	2.124	2.374
30/21	1.909	1.750	1.750	2.100	2.111	2.333
35/25	1.923	1.786	1.786	2.083	2.091	2.272
40/29	1.933	1.813	1.813	2.071	2.077	2.231
45/32	2.000	1.829	1.829	2.000	2.069	2.207
50/35	1.944	1.842	1.842	2.059	2.062	2.187

Table 4.3. Ratios A/A_{eff} , W/W_{eff} , and I/I_{eff} of sanded birch plywood Riga Ply

Nominal thickness and number of veneers	Along the grain direction of the face veneers			Across the grain direction of the face veneers		
	A/A_{eff}	W/W_{eff}	I/I_{eff}	A/A_{eff}	W/W_{eff}	I/I_{eff}
4/3	1.636	1.062	1.062	2.571	6.613	17.003
6.5/5	1.778	1.374	1.374	2.286	2.411	3.674
9/7	1.840	1.536	1.536	2.190	2.181	2.866
12/9	1.875	1.633	1.633	2.143	2.108	2.581
15/11	1.897	1.696	1.696	2.114	2.074	2.436
18/13	1.913	1.742	1.742	2.095	2.055	2.348
21/15	1.925	1.775	1.775	2.082	2.043	2.290
24/17	1.933	1.801	1.801	2.071	2.035	2.248
27/19	1.940	1.822	1.822	2.063	2.030	2.217
30/21	1.946	1.838	1.838	2.057	2.025	2.193
35/25	1.955	1.864	1.864	2.048	2.020	2.158
40/29	1.961	1.883	1.883	2.041	2.016	2.133
45/32	2.028	1.893	1.893	1.973	2.014	2.119
50/35	1.967	1.903	1.903	2.034	2.012	2.108

Table 4.4. Characteristic bending strength f_{mk} of birch plywood Riga Ply

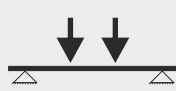

Nominal thickness and number of veneers	Unsanded		Sanded	
	$f_{mk\parallel}$, N/mm ²	$f_{mk\perp}$, N/mm ²	$f_{mk\parallel}$, N/mm ²	$f_{mk\perp}$, N/mm ²
4/3	77.0	8.9	75.3	12.1
6.5/5	63.4	27.7	58.2	33.2
9/7	56.9	32.3	52.1	36.7
12/9	53.2	34.4	49.0	38.0
15/11	50.8	35.6	47.2	38.6
18/13	49.2	36.4	45.9	38.9
21/15	48.0	37.0	45.1	39.2
24/17	47.0	37.4	44.4	39.3
27/19	46.3	37.7	43.9	39.4
30/21	45.7	37.9	43.5	39.5
35/25	44.8	38.3	42.9	39.6
40/29	44.1	38.5	42.5	39.7
45/32	43.7	38.7	42.3	39.7
50/35	43.4	38.8	42.0	39.8

Table 4.5. Characteristic compression strength f_{ck} of birch plywood Riga Ply

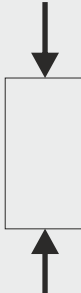

Nominal thickness and number of veneers	Unsanded		Sanded	
	$f_{ck\parallel}$, N/mm ²	$f_{ck\perp}$, N/mm ²	$f_{ck\parallel}$, N/mm ²	$f_{ck\perp}$, N/mm ²
4/3	38.7	19.3	35.4	22.6
6.5/5	34.8	23.2	32.6	25.4
9/7	33.1	24.9	31.5	26.5
12/9	32.2	25.8	30.9	27.1
15/11	31.6	26.4	30.6	27.4
18/13	31.2	26.8	30.3	27.7
21/15	30.9	27.1	30.1	27.9
24/17	30.7	27.3	30.0	28.0
27/19	30.5	27.5	29.9	28.1
30/21	30.4	27.6	29.8	28.2
35/25	30.2	27.8	29.7	28.3
40/29	30.0	28.0	29.6	28.4
45/32	29.0	29.0	28.6	29.4
50/35	29.8	28.2	29.5	28.5

Table 4.6. Characteristic tension strength f_{tk} of birch plywood Riga Ply



Nominal thickness and number of veneers	Unsanded		Sanded	
	$f_{tk \parallel}$, N/mm ²	$f_{tk \perp}$, N/mm ²	$f_{tk \parallel}$, N/mm ²	$f_{tk \perp}$, N/mm ²
4/3	52.0	26.0	47.7	30.3
6.5/5	46.8	31.2	43.9	34.1
9/7	44.6	33.4	42.4	35.6
12/9	43.3	34.7	41.6	36.4
15/11	42.5	35.5	41.1	36.9
18/13	42.0	36.0	40.8	37.2
21/15	41.6	36.4	40.5	37.5
24/17	41.3	36.7	40.3	37.7
27/19	41.1	36.9	40.2	37.8
30/21	40.9	37.1	40.1	37.9
35/25	40.6	37.4	39.9	38.1
40/29	40.3	37.7	39.8	38.2
45/32	39.0	39.0	38.5	39.5
50/35	40.1	37.9	39.6	38.4

Table 4.7. Characteristic shear strength in panel shear f_{pak} of birch plywood Riga Ply

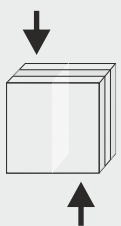

Nominal thickness and number of veneers	Unsanded		Sanded	
	$f_{pak \parallel}$, N/mm ²	$f_{pak \perp}$, N/mm ²	$f_{pak \parallel}$, N/mm ²	$f_{pak \perp}$, N/mm ²
4/3	10.0	10.0	10.0	10.0
6.5/5	10.0	10.0	10.0	10.0
9/7	10.0	10.0	10.0	10.0
12/9	10.0	10.0	10.0	10.0
15/11	10.0	10.0	10.0	10.0
18/13	10.0	10.0	10.0	10.0
21/15	10.0	10.0	10.0	10.0
24/17	10.0	10.0	10.0	10.0
27/19	10.0	10.0	10.0	10.0
30/21	10.0	10.0	10.0	10.0
35/25	10.0	10.0	10.0	10.0
40/29	10.0	10.0	10.0	10.0
45/32	10.0	10.0	10.0	10.0
50/35	10.0	10.0	10.0	10.0

Table 4.8. Characteristic shear strength in planar shear f_{plik} of birch plywood Riga Ply

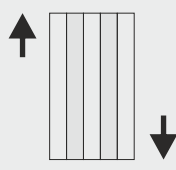

Nominal thickness and number of veneers	Unsanded		Sanded	
	$f_{plik \parallel}$, N/mm ²	$f_{plik \perp}$, N/mm ²	$f_{plik \parallel}$, N/mm ²	$f_{plik \perp}$, N/mm ²
4/3	2.38	-	2.44	-
6.5/5	2.72	1.43	2.81	1.56
9/7	2.40	1.94	2.36	2.07
12/9	2.47	1.86	2.45	1.96
15/11	2.35	2.02	2.31	2.10
18/13	2.38	1.99	2.35	2.06
21/15	2.32	2.06	2.28	2.12
24/17	2.34	2.05	2.30	2.10
27/19	2.30	2.09	2.27	2.14
30/21	2.31	2.08	2.28	2.12
35/25	2.29	2.10	2.26	2.14
40/29	2.28	2.12	2.25	2.15
45/32	0.91	2.14	0.90	2.17
50/35	2.26	2.14	2.24	2.17

Table 4.9. Mean modulus of elasticity E in bending of birch plywood Riga Ply

Nominal thickness and number of veneers	Unsanded		Sanded	
	E , N/mm ²	E _⊥ , N/mm ²	E , N/mm ²	E _⊥ , N/mm ²
4/3	17333	667	16941	1059
6.5/5	14256	3744	13101	4899
9/7	12805	5195	11720	6280
12/9	11975	6025	11026	6974
15/11	11441	6559	10611	7389
18/13	11069	6931	10335	7665
21/15	10795	7205	10140	7860
24/17	10585	7415	9994	8006
27/19	10418	7582	9881	8119
30/21	10284	7716	9791	8209
35/25	10079	7921	9657	8343
40/29	9930	8070	9562	8438
45/32	9844	8156	9507	8493
50/35	9771	8229	9461	8539

Table 4.10. Mean modulus of elasticity E in tension and compression of Riga Ply

Nominal thickness and number of veneers	Unsanded		Sanded	
	E , N/mm ²	E _⊥ , N/mm ²	E , N/mm ²	E _⊥ , N/mm ²
4/3	12000	6000	11000	7000
6.5/5	10800	7200	10125	7875
9/7	10286	7714	9783	8217
12/9	10000	8000	9600	8400
15/11	9818	8182	9486	8514
18/13	9692	8308	9409	8591
21/15	9600	8400	9353	8647
24/17	9529	8471	9310	8690
27/19	9474	8526	9277	8723
30/21	9429	8571	9250	8750
35/25	9360	8640	9209	8791
40/29	9310	8690	9180	8820
45/32	9000	9000	8878	9122
50/35	9257	8743	9149	8851

Table 4.11. Mean modulus of rigidity G in panel shear of birch plywood Riga Ply

Nominal thickness and number of veneers	Unsanded		Sanded	
	G , N/mm ²	G _⊥ , N/mm ²	G , N/mm ²	G _⊥ , N/mm ²
4/3	750	750	750	750
6.5/5	750	750	750	750
9/7	750	750	750	750
12/9	750	750	750	750
15/11	750	750	750	750
18/13	750	750	750	750
21/15	750	750	750	750
24/17	750	750	750	750
27/19	750	750	750	750
30/21	750	750	750	750
35/25	750	750	750	750
40/29	750	750	750	750
45/32	750	750	750	750
50/35	750	750	750	750

Table 4.12. Mean modulus of rigidity **G** in planar shear of birch plywood Riga Ply

Nominal thickness and number of veneers	Unsanded		Sanded	
	G_{\parallel} , N/mm ²	G_{\perp} , N/mm ²	G_{\parallel} , N/mm ²	G_{\perp} , N/mm ²
4/3	172	-	155	-
6.5/5	187	103	183	113
9/7	191	134	189	142
12/9	192	149	190	156
15/11	192	157	190	163
18/13	192	162	189	168
21/15	191	166	189	171
24/17	191	169	188	173
27/19	190	171	188	174
30/21	190	172	188	176
35/25	189	174	187	177
40/29	188	176	187	178
45/32	178	188	176	190
50/35	188	177	176	179

Table 4.13. Characteristic bending moment capacity **M** of birch plywood Riga Ply for the full cross-section along and perpendicular to the grain

Nominal thickness and number of veneers	Unsanded		Sanded	
	M_{\parallel} , Nm/m	M_{\perp} , Nm/m	M_{\parallel} , Nm/m	M_{\perp} , Nm/m
4/3	226	26	163	26
6.5/5	517	226	397	226
9/7	911	517	735	517
12/9	1408	911	1176	911
15/11	2010	1408	1722	1408
18/13	2716	2010	2371	2010
21/15	3526	2716	3126	2716
24/17	4441	3526	3985	3526
27/19	5460	4441	4948	4441
30/21	6584	5460	6016	5460
35/25	9146	7813	8465	7813
40/29	12125	10583	11332	10583
45/32	14635	12934	13758	12934
50/35	17378	15522	16417	15522

Table 4.14. Characteristic compression capacity **N_c** of birch plywood Riga Ply

Nominal thickness and number of veneers	Unsanded		Sanded	
	$N_{c\parallel}$, MN/m	$N_{c\perp}$, MN/m	$N_{c\parallel}$, MN/m	$N_{c\perp}$, MN/m
4/3	0.162	0.081	0.128	0.081
6.5/5	0.244	0.162	0.209	0.162
9/7	0.325	0.244	0.290	0.244
12/9	0.406	0.325	0.371	0.325
15/11	0.487	0.406	0.452	0.406
18/13	0.568	0.487	0.534	0.487
21/15	0.650	0.568	0.615	0.568
24/17	0.731	0.650	0.696	0.650
27/19	0.812	0.731	0.777	0.731
30/21	0.893	0.812	0.858	0.812
35/25	1.056	0.974	1.021	0.974
40/29	1.218	1.137	1.183	1.137
45/32	1.299	1.299	1.264	1.299
50/35	1.462	1.380	1.427	1.380

Table 4.15. Characteristic tension capacity N_t of birch plywood Riga Ply

Nominal thickness and number of veneers	Unsanded		Sanded	
	$N_{t \parallel}$, MN/m	$N_{t \perp}$, MN/m	$N_{t \parallel}$, MN/m	$N_{t \perp}$, MN/m
4/3	0.218	0.109	0.172	0.109
6.5/5	0.328	0.218	0.281	0.218
9/7	0.437	0.328	0.390	0.328
12/9	0.546	0.437	0.499	0.437
15/11	0.655	0.546	0.608	0.546
18/13	0.764	0.655	0.718	0.655
21/15	0.874	0.764	0.827	0.764
24/17	0.983	0.874	0.936	0.874
27/19	0.092	0.983	1.045	0.983
30/21	1.201	1.092	1.154	1.092
35/25	1.420	1.310	1.373	1.310
40/29	1.638	1.529	1.591	1.529
45/32	1.747	1.747	1.700	1.747
50/35	1.966	1.856	1.919	1.856

Table 4.16. Characteristic shear capacity in panel shear V_{pa} of birch plywood Riga Ply for the full cross-section along and perpendicular to the grain

Nominal thickness and number of veneers	Unsanded		Sanded	
	$V_{pa \parallel}$, kN/m	$V_{pa \perp}$, kN/m	$V_{pa \parallel}$, kN/m	$V_{pa \perp}$, kN/m
4/3	42	42	36	36
6.5/5	70	70	64	64
9/7	98	98	92	92
12/9	126	126	120	120
15/11	154	154	148	148
18/13	182	182	176	176
21/15	210	210	204	204
24/17	238	238	232	232
27/19	266	266	260	260
30/21	294	294	288	288
35/25	350	350	344	344
40/29	406	406	400	400
45/32	448	448	442	442
50/35	490	490	484	484

Table 4.17. Characteristic shear capacity in planar shear V_{pl} of birch plywood Riga Ply for the full cross-section along and perpendicular to the grain

Nominal thickness and number of veneers	Unsanded		Sanded	
	$V_{pl \parallel}$, kN/m	$V_{pl \perp}$, kN/m	$V_{pl \parallel}$, kN/m	$V_{pl \perp}$, kN/m
4/3	6.7	-	5.9	-
6.5/5	12.7	6.7	12.0	6.7
9/7	15.7	12.7	14.5	12.7
12/9	20.7	15.7	19.6	15.7
15/11	24.1	20.7	22.8	20.7
18/13	28.9	24.1	27.5	24.1
21/15	32.5	28.9	31.0	28.9
24/17	31.7	32.5	35.6	32.5
27/19	40.8	37.1	39.3	37.1
30/21	45.3	40.8	43.8	40.8
35/25	53.5	49.0	51.9	49.0
40/29	61.7	57.3	60.1	57.3
45/32	27.1	64.1	26.4	64.1
50/35	73.7	69.9	72.1	69.9

Table 4.18. Mean stiffness EI in bending of birch plywood Riga Ply

Nominal thickness and number of veneers	Unsanded		Sanded	
	EI \parallel , kNm ²	EI \perp , kNm ²	EI \parallel , kNm ²	EI \perp , kNm ²
4/3	0.107	0.004	0.066	0.004
6.5/5	0.407	0.107	0.286	0.107
9/7	1.004	0.407	0.761	0.407
12/9	1.996	1.004	1.588	1.004
15/11	3.482	1.996	2.866	1.996
18/13	5.561	3.482	4.696	3.482
21/15	8.331	5.561	7.174	5.561
24/17	11.891	8.331	10.400	8.331
27/19	16.341	11.891	14.473	11.891
30/21	21.778	16.341	19.491	16.341
35/25	36.001	28.302	32.760	28.302
40/29	55.381	45.004	50.996	45.004
45/32	73.759	61.114	68.412	61.114
50/35	95.796	80.678	89.392	80.678

Table 4.19. Mean stiffness EA in tension and compression of birch plywood Riga Ply for the full cross-section along and perpendicular to the grain

Nominal thickness and number of veneers	Unsanded		Sanded	
	EA \parallel , MN/m	EA \perp , MN/m	EA \parallel , MN/m	EA \perp , MN/m
4/3	50	25	40	25
6.5/5	76	50	65	50
9/7	101	76	90	76
12/9	126	101	115	101
15/11	151	126	140	126
18/13	176	151	166	151
21/15	202	176	191	176
24/17	227	202	216	202
27/19	252	227	241	227
30/21	277	252	266	252
35/25	328	302	317	302
40/29	378	353	367	353
45/32	403	403	392	403
50/35	454	428	443	428

Table 4.20. Mean shear rigidity GA in panel shear in bending of birch plywood Riga Ply for the full cross-section along and perpendicular to the grain

Nominal thickness and Number of veneers	Unsanded		Sanded	
	GA \parallel , MN/m	GA \perp , MN/m	GA \parallel , MN/m	GA \perp , MN/m
4/3	3.15	3.15	2.70	2.70
6.5/5	5.25	5.25	4.80	4.80
9/7	7.35	7.35	6.90	6.90
12/9	9.45	9.45	9.00	9.00
15/11	11.55	11.55	11.10	11.10
18/13	13.65	13.65	13.20	13.20
21/15	15.75	15.75	15.30	15.30
24/17	17.85	17.85	17.40	17.40
27/19	19.95	19.95	19.50	19.50
30/21	22.05	22.05	21.60	21.60
35/25	26.25	26.25	25.80	25.80
40/29	30.45	30.45	30.00	30.00
45/32	33.60	33.60	33.15	33.15
50/35	36.75	36.75	36.30	36.30

Table 4.21. Mean shear rigidity GA in planar shear of birch plywood Riga Ply for the full cross-section along and perpendicular to the grain

Nominal thickness and number of veneers	Unsanded		Sanded	
	GA II, MN/m	GA ⊥, MN/m	GA II, MN/m	GA ⊥, MN/m
4/3	0.723	-	0.556	-
6.5/5	1.310	0.723	1.169	0.723
9/7	1.873	1.310	1.735	1.310
12/9	2.419	1.873	2.277	1.873
15/11	2.955	2.419	2.807	2.419
18/13	3.486	2.955	3.331	2.955
21/15	4.012	3.486	3.852	3.486
24/17	4.536	4.012	4.370	4.012
27/19	5.057	4.536	4.888	4.536
30/21	5.577	5.057	5.404	5.057
35/25	6.614	6.096	6.435	6.096
40/29	7.649	7.132	7.465	7.132
45/32	7.971	8.416	7.783	8.416
50/35	9.197	8.682	9.008	8.682





design

general explanatory notes	5-1
uniform load	5-3
floors - uniform load	5-4
concrete formworks - uniform load	5-8
concentrated load	5-10
concentrated load over an area 50×50 mm	5-11
concentrated load over an area 80×180 mm	5-15

5.1. General explanatory notes

According to Latvijas Finieris order to VTT institute in 2004, VTT evaluated load resistance values of plywood in different cases. The design is carried out in accordance with prEN 1995-1-1 Eurocode 5, Design of timber structures, Part 1:1 General - Common rules and rules for buildings.

The mechanical characteristics of plywood produced in Sastamala, Finland, correspond to the parameters indicated in The Handbook of Finnish Plywood.

In design it shall be proven that the design bending stress $\sigma_{m,d}$ is less than the design bending strength $f_{m,d}$:

$$\sigma_{m,d} \leq f_{m,d} \quad [5.1.]$$

The design bending stress is calculated from the design load. The design load is given by combining the characteristic loads multiplied with their respective partial safety factors γ_q . The design bending strength is given by dividing the characteristic bending strength $f_{m,k}$ by the partial safety factor γ_m for materials (for plywood 1.2). Hence,

$$\sigma_{m,d} = \gamma_q \sigma_{m,k} \quad [5.2.]; \quad f_{m,d} = \frac{k_{mod}}{\gamma_m} f_{m,k} \quad [5.3.],$$

where: $\sigma_{m,k}$ - the characteristic bending stress;

k_{mod} - factor taking into account the effect of duration of load and moisture content.

In design it shall be proven that the design shear stress $\tau_{v,d}$ is less than the design shear strength $f_{v,d}$:

$$\tau_{v,d} \leq f_{v,d} \quad [5.4.]$$

The design shear stress is calculated from the design load. The design load is given by combining the characteristic loads multiplied with their respective partial safety factors γ_q . The design shear strength is given by dividing the characteristic shear strength $f_{v,k}$ by the partial safety factor γ_m for materials. Hence,

$$\tau_{v,d} = \gamma_q \tau_{v,k} \quad [5.5.]; \quad f_{v,d} = \frac{k_{mod}}{\gamma_m} f_{v,k} \quad [5.6.],$$

where: $\tau_{v,k}$ - the characteristic shear stress;

k_{mod} - factor taking into account the effect of duration of load and moisture content (see Table 5.1).

* According to Eurocode 5, Design of timber structures, Part 1:1 General - Common rules and rules for buildings

** Load - duration class description is given in Table 5.3

*** Service class description is given in Table 5.2

Table 5.1. Values of k_{mod} *

Service class ***	Load duration class**				
	Permanent action	Long term action	Medium term action	Short term action	Instantaneous action
1	0.60	0.70	0.80	0.90	1.10
2	0.60	0.70	0.80	0.90	1.10
3	0.50	0.55	0.65	0.70	0.90

Table 5.2. Service classes

Service class	Description of service class	Average moisture content for plywood, %
1	Characterised by moisture content in the materials corresponding to a temperature of 20°C and the relative humidity of the surrounding air only exceeding 65% for a few weeks per year	11
2	Characterised by moisture content in the materials corresponding to a temperature of 20°C and the relative humidity of the surrounding air only exceeding 85% for a few weeks per year	17
3	Characterised by climatic conditions leading to higher moisture content than in service class 2	above 17

Table 5.3. Load - duration classes

Load - duration class	Order of accumulated duration of characteristic load	Example of load
Permanent	more than 10 years	Net weight
Long term	6 months - 10 years	Actual load
Medium term	1 week - 6 months	Snow, temporary load
Short term	less than 1 week	Wind, snow load
Instantaneous		Wind, occasional load

Note: Since climatic loads (snow, wind) vary between countries, information on their load duration assignment may be specified in the National annex.

Furthermore, it shall be proven that the design final deflection u_{fin} is less than the pre-set deflection value u_{preset} .

$$u_{fin} = u_{fin,permanent} + u_{fin,quasi,permanent} \leq u_{preset} \quad [5.7.],$$

where the final deformation calculated from the permanent loads $u_{fin,permanent}$ and the final deformation calculated from the quasi-permanent loads $u_{fin,quasi,permanent}$ are given by

$$u_{fin,permanent} = u_{inst} (1+k_{def}) \quad [5.8.]; \quad u_{fin,quasi,permanent} = u_{inst} (1+\psi_2 k_{def}) \quad [5.9.],$$

where: u_{inst} - the instantaneous deformation;

ψ_2 - the factor for the quasi-permanent value of a variable load;

k_{def} - factor taking into account the effect of duration of load and moisture content.

The pre-set deflection value depends on the construction and it is usually given as a deflection related to the span length, for example $L_{span}/300$ or $L_{span}/200$. However, absolute pre-set deflection values may also be given. k_{def} is a factor taking into account the effect of duration of load and moisture content and given in Table 5.4.

Table 5.4. Values k_{def} *

Standard	Service class		
	1	2	3
EN 636	0.80	1.00	2.50

* According to Eurocode 5, Design of timber structures, Part 1:1 General - Common rules and rules for buildings.

Furthermore, the section properties as well as the strength and stiffness values of birch plywood Riga Ply are given in the chapter Mechanical properties.

5.2. Uniform load

In the stress and deflection calculations a plate strip of unite width ($b = 1$ mm) is considered. This means that the cross - section area A is given in mm^2/mm , section modulus W is given in mm^3/mm and second moment of plane area I is given in mm^4/mm . For a uniformly distributed load on a simple supported plate the critical bending stress and shear stress are given by equations [5.10] and [5.11], respectively. The critical deflection $u_{M+V} \approx u_M$ is given by the first term of equation [5.12]. The shorter side of the plate shall be used as the span length L_{span} . The factors, α , β and φ are given in Table 5.5.

For a uniformly distributed load on a continuous plate strip with equal span lengths the critical bending stress σ is given by

$$\sigma = \frac{M_{cri}}{W} = \alpha \frac{qL_{span}^2}{W} \quad [5.10.],$$

where: q - the uniformly distributed load per area;

L_{span} - the span length;

W - ($= t^2/6$) is the section modulus of the full cross-section of the plate strip;

t - the thickness of the plate strip;

α - is given in Table 5.5.

The critical shear stress τ is given by

$$\tau = \frac{3}{2} \frac{V_{cri}}{A} = \frac{3}{2} \beta \frac{qL_{span}}{A} \quad [5.11.],$$

where: A - ($= t$) is the area of the full cross-section of the plate strip;

β - is given in Table 5.5.

The critical deflection u_{M+V} is given by

$$u_{M+V} = \varphi \frac{qL_{span}^4}{EI} + \psi \frac{qL_{span}^2}{5GA} \quad [5.12.],$$

where: I - ($= t^3/12$) is the second moment of plane area of the full cross-section of the plate strip;

E - the modulus of elasticity;

G - the shear modulus;

φ , ψ - given in Table 5.5.

Table 5.5. α , β , φ and ψ factors to be used in equations [5.10.] - [5.12]

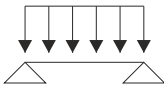
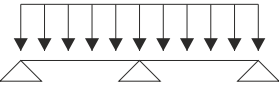
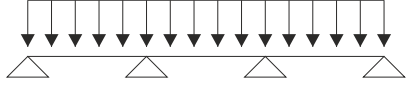
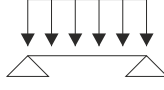
Number of spans		α	β	φ	ψ
	Strip	0.125	0.500	0.0130	0.125
	Strip	0.125	0.625	0.0054	0.149
	Strip	0.100	0.600	0.0069	0.133
	Plate	0.041 -	0.226 -	0.0043 -	-
		0.125	0.500	0.0130	

5.3. Floors - Uniform load

The object of this section is to present and document tabulated uniformly distributed load resistance values for floors of birch plywood Riga Ply produced by Latvijas Finieris. The calculation is carried out in accordance with VTT research protocol RTE 3968-04 and prEN 1995-1-1 Eurocode 5, Design of timber structures, Part 1:1 General - Common rules and rules for buildings.

The load resistance values for: an uniformly distributed load on a single span plate strip; a uniformly distributed load on a double span plate strip; a uniformly distributed load on a simple supported plate given in Tables 5.6 - 5.8 are calculated according to the following assumptions: $\gamma_q=1.5$; $\gamma_m=1.2$; $k_{mod}=0.80$. Hence, the characteristic load acting in service classes 1 or 2 (dry or humid) and load duration class Medium - term (1 week to 6 months) shall not exceed the tabulated values.

The deflection values given in Tables 5.6 - 5.8 are calculated according to the following assumptions: $k_{def}=0.8$; $\psi_2=0.3$; the load used is the tabulated load resistance assumed to be totally quasi-permanent.

For other assumptions the tabulated load resistance values shall be multiplied by a correction factor $k_{load,corr}$ given by

$$k_{load,corr} = \frac{k_{mod}}{\gamma_m \gamma_q} \frac{1.2 \times 1.5}{0.80} \quad [5.13].$$

For other assumptions the tabulated deflection values shall be multiplied by a correction factor $k_{def,corr}$ given by

$$k_{def,corr} = \frac{1 + \psi_2 k_{def}}{1 + 0.24} k_{load,corr} \quad [5.14].$$

Table 5.6. Load resistance for a uniformly distributed load on a sanded single span plate strip

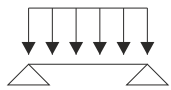

Simply supported
single span plate strip

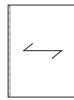

Service Class 1

$$k_{mod}=0.8 \quad \psi_2=0.3 \quad \gamma_m=1.2$$

$$k_{def}=0.8 \quad \gamma_q=1.5$$

Span c/c mm	Uniformly distributed load q (kN/m ²) and deflection u (mm) Nominal thickness (mm)															
	4		6.5		9		12		15		18		21			
	q	u	q	u	q	u	q	u	q	u	q	u	q	u		
300	6.4	b 13	16	b 7.4	29	b 5.3	46	b 4.2	68	b 3.5	82	b 2.7	92	b 2.1		
400	3.6	b 23	8.8	b 13	16	b 9.2	26	b 7.1	38	b 5.9	53	b 5.1	69	b 4.5		
500	2.3	b 36	5.7	b 20	10	b 14	17	b 11	25	b 9.0	34	b 7.7	44	b 6.8		
600	1.6	b 51	3.9	b 29	7.3	b 20	12	b 16	17	b 13	23	b 11	31	b 10		
750	1.0	b 80	2.5	b 45	4.6	b 31	7.4	b 24	11	b 20	15	b 17	20	b 15		
1000	0.58	b 142	1.4	b 80	2.6	b 56	4.2	b 43	6.1	b 35	8.4	b 29	11	b 26		
1200	0.40	b 204	1.0	b 115	1.8	b 80	2.9	b 62	4.3	b 50	5.9	b 42	7.7	b 37		
1500	0.26	b 319	0.6	b 180	1.2	b 125	1.9	b 96	2.7	b 78	3.7	b 66	4.9	b 57		

Span c/c mm	Uniformly distributed load q (kN/m ²) and deflection u (mm) Nominal thickness (mm)															
	24		27		30		35		40		45		50			
	q	u	q	u	q	u	q	u	q	u	q	u	q	u		
300	105	s 1.7	117	s 1.5	130	s 1.3	154	s 1.0	178	s 0.85	79	s 0.32	214	s 0.71		
400	79	s 3.7	87	s 3.0	97	s 2.6	115	s 2.0	133	s 1.6	59	s 0.58	161	s 1.3		
500	57	b 6.1	70	s 5.5	78	s 4.7	92	s 3.5	107	s 2.8	47	s 1.0	128	s 2.1		
600	39	b 8.5	49	b 7.7	59	b 7.1	77	s 5.7	89	s 4.4	39	s 1.5	107	s 3.3		
750	25	b 13	31	b 12	38	b 11	53	b 9.2	71	s 8.1	31	s 2.8	86	s 5.9		
1000	14	b 23	18	b 20	21	b 18	30	b 16	40	b 14	24	s 6.1	58	b 12		
1200	10	b 32	12	b 29	15	b 26	21	b 22	28	b 19	20	s 10	40	b 16		
1500	6.3	b 50	7.8	b 45	10	b 41	13	b 34	18	b 30	16	s 20	26	b 25		

Table 5.7. Load resistance for a uniformly distributed load on a sanded double span plate strip

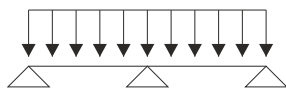

Simply supported
double span plate strip

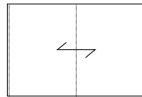

Service class 1

$$k_{mod}=0.8 \quad \psi_2=0.3 \quad \gamma_m=1.2$$

$$k_{def}=0.8 \quad \gamma_q=1.5$$

Span c/c mm	Uniformly distributed load q (kN/m ²) and deflection u (mm) Nominal thickness (mm)															
	4		6.5		9		12		15		18		21			
	q	u	q	u	q	u	q	u	q	u	q	u	q	u		
300	6.4	b 5.5	16	b 3.2	29	b 2.4	46	b 2.0	68	b 1.4	82	b 1.1	92	b 0.94		
400	3.6	b 10	8.8	b 5.6	16	b 4.0	26	b 3.2	38	b 2.8	53	b 2.3	69	b 1.8		
500	2.3	b 15	5.7	b 8.5	10	b 6.1	17	b 4.8	25	b 4.1	34	b 3.6	44	b 3.2		
600	1.6	b 21	3.9	b 12	7.3	b 8.6	12	b 6.8	17	b 5.6	23	b 4.9	31	b 4.4		
750	1.0	b 33	2.5	b 19	4.6	b 13	7.4	b 10	11	b 8.5	15	b 7.3	20	b 6.5		
1000	0.58	b 59	1.4	b 33	2.6	b 23	4.2	b 18	6.1	b 15	8.4	b 13	11	b 11		
1200	0.40	b 85	1.0	b 48	1.8	b 33	2.9	b 26	4.3	b 21	5.9	b 18	7.7	b 16		
1500	0.26	b 133	0.6	b 75	1.2	b 52	1.9	b 40	2.7	b 33	3.7	b 28	4.9	b 24		

Span c/c mm	Uniformly distributed load q (kN/m ²) and deflection u (mm) Nominal thickness (mm)															
	24		27		30		35		40		45		50			
	q	u	q	u	q	u	q	u	q	u	q	u	q	u		
300	84	s 0.83	93	s 0.73	104	s 0.67	123	s 0.58	142	s 0.53	63	s 0.21	171	s 0.48		
400	63	s 1.6	70	s 1.3	78	s 1.2	92	s 1.0	107	s 0.86	47	s 0.33	128	s 0.75		
500	51	s 2.7	56	s 2.3	62	s 2.0	74	s 1.6	85	s 1.3	38	s 0.50	103	s 1.1		
600	39	b 4.0	47	s 3.6	52	s 3.1	61	s 2.4	71	s 2.0	31	s 0.72	86	s 1.6		
750	25	b 5.8	31	b 5.4	38	b 5.0	49	s 4.1	57	s 3.3	25	s 1.2	69	s 2.6		
1000	14	b 10	18	b 8.9	21	b 8.2	30	b 7.2	40	b 6.5	19	s 2.4	51	s 5.1		
1200	10	b 14	12	b 13	15	b 11	21	b 10	28	b 8.8	16	s 3.8	40	b 7.7		
1500	6.3	b 21	7.8	b 19	10	b 17	13	b 15	18	b 13	13	s 7.0	26	b 11		

Table 5.8. Load resistance for a uniformly distributed load on a sanded simple supported plate

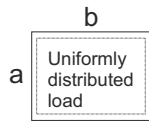

Simply supported rectangular plate

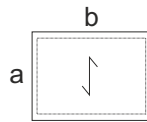

Service Class 1

$$k_{mod}=0.8 \quad \psi_2=0.3 \quad \gamma_m=1.2$$

$$k_{def}=0.8 \quad \gamma_q=1.5$$

Span c/c mm $a \times b$	Uniformly distributed load q (kN/m ²) and deflection u (mm) Nominal thickness (mm)													
	4		6.5		9		12		15		18		21	
	q	u	q	u	q	u	q	u	q	u	q	u	q	u
300×300	-	-	18 s	4.7	49 b	3.5	77 s	2.5	109 s	1.8	133 s	1.3	164 s	1.1
300×600	-	-	18 b	8.5	32 b	4.8	55 b	3.8	79 s	3.0	96 s	2.2	108 s	1.6
300×900	-	-	16 b	8.5	30 b	4.9	48 b	3.8	70 s	3.1	85 s	2.3	95 s	1.7
300×∞	-	-	16 b	8.5	29 b	5.0	46 b	3.8	68 s	3.1	82 s	2.3	92 s	1.7
400×400	-	-	10 s	8.4	27 b	6.2	52 b	5.3	82 s	4.4	100 s	3.2	123 s	2.5
400×800	-	-	9.9 b	15	18 b	8.5	31 b	6.8	46 b	5.5	64 b	4.6	81 s	3.8
400×1200	-	-	9.0 b	15	17 b	8.8	27 b	6.8	40 b	5.5	55 b	4.6	72 s	3.9
400×∞	-	-	8.8 b	15	16 b	8.9	26 b	6.8	38 b	5.5	53 b	4.6	69 s	4.0
500×500	-	-	6.5 b	13	18 b	10	33 b	8.2	54 b	7.1	79 b	6.2	98 s	4.9
500×1000	-	-	6.3 b	24	12 b	13	20 b	11	30 b	8.6	41 b	7.2	55 b	6.2
500×1500	-	-	5.8 b	24	11 b	14	17 b	11	26 b	8.6	35 b	7.2	47 b	6.3
500×∞	-	-	5.7 b	24	10 b	14	17 b	11	25 b	8.6	34 b	7.2	44 b	6.3
600×600	-	-	4.5 b	19	12 b	14	23 b	12	38 b	10	55 b	8.9	76 b	7.9
600×1200	-	-	4.4 b	34	8.1 b	19	14 b	15	21 b	12	29 b	10	38 b	9.0
600×1800	-	-	4.0 b	34	7.4 b	20	12 b	15	18 b	12	24 b	10	32 b	9.0
600×∞	-	-	3.9 b	34	7.3 b	20	12 b	15	17 b	12	23 b	10	31 b	9.0
750×750	-	-	2.9 b	30	7.8 b	22	15 b	19	24 b	16	35 b	14	49 b	12
750×1500	-	-	2.8 b	53	5.2 b	30	8.9 b	24	13 b	19	18 b	16	24 b	14
750×2250	-	-	2.6 b	53	4.7 b	31	8.7 b	24	11 b	19	16 b	16	21 b	14
750×∞	-	-	2.5 b	53	4.6 b	31	7.4 b	24	11 b	19	15 b	16	20 b	14
1000×1000	-	-	1.6 b	53	4.4 b	39	8.4 b	33	14 b	28	20 b	25	27 b	22
1000×2000	-	-	1.6 b	94	2.9 b	53	5.0 b	42	7.4 b	34	10 b	29	14 b	25
1000×3000	-	-	1.4 b	95	2.7 b	55	4.3 b	42	6.4 b	34	8.8 b	29	12 b	25
1000×∞	-	-	1.4 b	95	2.6 b	55	4.2 b	43	6.1 b	35	8.4 b	29	11 b	25
1200×1200	-	-	1.1 b	76	3.0 b	56	5.8 b	47	9.4 b	41	14 b	35	19 b	31
1200×2400	-	-	1.1 b	136	2.0 b	76	3.5 b	61	5.1 b	50	7.1 b	42	9.5 b	36
1500×1500	-	-	0.73 b	118	2.0 b	87	3.7 b	74	6.0 b	64	8.8 b	55	12 b	49
1500×3000	-	-	0.70 b	212	1.3 b	119	2.2 b	95	3.3 b	77	4.6 b	65	6.0 b	56

Span c/c mm a×b	Uniformly distributed load q (kN/m ²) and deflection u (mm) Nominal thickness (mm)													
	24		27		30		35		40		45		50	
	q	u	q	u	q	u	q	u	q	u	q	u	q	u
300×300	189 s	0.83	219 s	0.68	244 s	0.56	300 s	0.40	356 s	0.30	173 s	0.14	442 s	0.21
300×600	125 s	1.3	138 s	1.0	154 s	0.83	183 s	0.58	213 s	0.43	94 s	0.18	257 s	0.30
300×900	110 s	1.3	121 s	1.0	135 s	0.86	168 s	0.61	186 s	0.45	82 s	0.18	224 s	0.31
300×∞	105 s	1.3	117 s	1.1	130 s	0.87	154 s	0.61	178 s	0.46	79 s	0.19	214 s	0.31
400×400	141 s	2.0	164 s	1.6	183 s	1.3	225 s	1.0	267 s	0.72	130 s	0.32	331 s	0.50
400×800	94 s	3.0	104 s	2.4	116 s	2.0	138 s	1.4	160 s	1.0	71 s	0.4	193 s	0.71
400×1200	82 s	3.1	91 s	2.5	101 s	2.0	120 s	1.4	139 s	1.1	62 s	0.4	168 s	0.73
400×∞	79 s	3.1	87 s	2.5	97 s	2.1	115 s	1.5	133 s	1.1	59 s	0.4	161 s	0.74
500×500	113 s	3.8	132 s	3.2	146 s	2.6	180 s	1.9	214 s	1.4	104 s	0.6	265 s	1.0
500×1000	70 b	5.5	83 s	4.7	93 s	3.8	110 s	2.7	128 s	2.0	57 s	0.8	154 s	1.4
500×1500	59 b	5.5	73 s	4.8	81 s	4.0	96 s	2.8	111 s	2.1	49 s	0.9	134 s	1.4
500×∞	57 b	5.5	70 s	4.9	78 s	4.0	92 s	2.8	107 s	2.1	47 s	0.9	128 s	1.5
600×600	94 s	6.6	110 s	5.4	122 s	4.5	150 s	3.2	178 s	2.4	86 s	1.1	221 s	1.7
600×1200	49 b	7.9	61 b	7.1	74 b	6.4	92 s	4.7	106 s	3.5	47 s	1.4	129 s	2.4
600×1800	41 b	7.9	51 b	7.1	62 b	6.4	80 s	4.9	93 s	3.6	41 s	1.5	112 s	2.5
600×∞	39 b	7.9	49 b	7.1	59 b	6.4	77 s	4.9	89 s	3.6	39 s	1.5	107 s	2.5
750×750	64 b	11	82 b	10	98 s	8.7	120 s	6.3	142 s	4.7	69 s	2.1	177 s	3.3
750×1500	31 b	12	39 b	11	47 b	10	67 b	8.3	85 s	6.8	38 s	2.8	103 s	4.7
750×2250	26 b	12	33 b	11	40 b	10	56 b	8.3	74 s	7.0	33 s	2.9	90 s	4.8
750×∞	25 b	12	31 b	11	38 b	10	53 b	8.3	71 s	7.1	31 s	2.9	86 s	4.9
1000×1000	36 b	20	46 b	18	57 b	16	83 b	14	107 s	11	52 s	5.0	133 s	7.9
1000×2000	17 b	22	22 b	20	27 b	18	38 b	15	51 b	13	28 s	6.6	73 b	11
1000×3000	15 b	22	18 b	20	22 b	18	32 b	15	43 b	13	25 s	6.8	62 b	11
1000×∞	14 b	22	18 b	20	21 b	18	30 b	15	40 b	13	24 s	6.9	58 b	11
1200×1200	25 b	28	32 b	25	40 b	23	58 b	20	79 b	17	43 s	8.7	110 s	14
1200×2400	12 b	32	15 b	28	18 b	25	26 b	21	35 b	18	24 s	11	51 b	15
1500×1500	16 b	44	21 b	40	25 b	36	37 b	31	51 b	27	35 s	17	75 b	23
1500×3000	7.8 b	49	10 b	44	12 b	40	17 b	33	22 b	29	19 s	22	33 b	24

5.4. Concrete formworks - uniform load

The object of this section is to present and document tabulated uniformly distributed load resistance values for concrete formworks of birch plywood - Riga Ply produced by Latvijas Finieris. The calculation is carried out in accordance with VTT research protocol RTE 3971-04 and prEN 1995-1-1 Eurocode 5, Design of timber structures, Part 1:1 General - Common rules and rules for buildings.

The load resistance values for an uniformly distributed load on a plate strip with three equal span lengths given in Tables 5.9 - 5.10 are calculated according to the following assumptions: $\gamma_q=1.2$; $\gamma_m=1.2$; $k_{mod}=0.70$. Hence, the characteristic load acting in service class 3 (exterior) and load duration class Short - term (less than one week) shall not exceed the tabulated values. For other assumptions the tabulated load resistance values shall be multiplied by a correction factor $k_{load,corr}$ given by equation [5.15].

The deflection values given in Tables 5.9 - 5.10 are calculated according to the following assumptions: $k_{def}=2.5$; $\psi_2=0.2$; The load used is the tabulated load resistance assumed to be totally quasi-permanent. For other assumptions the tabulated deflection values shall be multiplied by a correction factor $k_{def,corr}$ given by equation [5.16].

Table 5.9. Load resistance for a uniformly distributed load on a sanded continuous plate strip with three equal span lengths

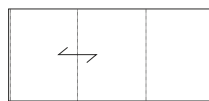
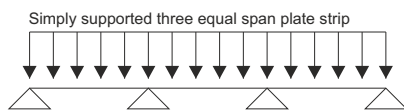

Service Class 1

$$K_{mod}=0.7 \quad \psi_2=0.2 \quad \gamma_m=1.2$$

$$K_{def}=2.5 \quad \Gamma_q=1.2$$

Span c/c mm	Uniformly distributed load q (kN/m ²) and deflection u (mm)															
	Nominal thickness (mm)															
	4		6.5		9		12		15		18		21			
	q	u	q	u	q	u	q	u	q	u	q	u	q	u		
100	47	s 0.95	97	s 0.55	117	s 0.32	159	s 0.27	185	s 0.22	223	s 0.21	251	s 0.19		
150	32	s 2.8	65	s 1.5	78	s 0.78	106	s 0.60	123	s 0.46	149	s 0.41	167	s 0.36		
200	20	b 5.3	48	b 3.2	59	s 1.6	79	s 1.2	92	s 0.85	112	s 0.72	126	s 0.60		
250	13	b 8.1	31	b 4.8	47	s 2.9	64	s 2.0	74	s 1.4	89	s 1.2	100	s 1.0		
300	8.8	b 12	21	b 6.7	39	s 4.8	53	s 3.3	62	s 2.3	74	s 1.8	84	s 1.4		
350	6.5	b 16	16	b 9.0	29	b 6.4	45	s 5.0	53	s 3.4	64	s 2.7	72	s 2.1		
400	4.9	b 20	12	b 12	22	b 8.3	36	b 6.6	46	s 4.9	56	s 3.8	63	s 2.9		
500	3.2	b 31	7.7	b 18	14	b 13	23	b 9.9	34	b 8.3	45	s 7.0	50	s 5.3		
600	2.2	b 45	5.4	b 26	10	b 18	16	b 14	23	b 12	32	b 10	42	s 8.8		
	24		27		30		35		40		45		50			
	q	u	q	u	q	u	q	u	q	u	q	u	q	u		
100	288	s 0.19	319	s 0.18	355	s 0.18	420	s 0.17	486	s 0.17	215	s 0.07	586	s 0.16		
150	192	s 0.33	213	s 0.31	236	s 0.30	280	s 0.28	324	s 0.27	143	s 0.11	390	s 0.26		
200	144	s 0.55	159	s 0.49	177	s 0.46	210	s 0.42	243	s 0.39	107	s 0.16	293	s 0.37		
250	115	s 0.84	128	s 0.75	142	s 0.69	168	s 0.60	194	s 0.54	86	s 0.22	234	s 0.50		
300	96	s 1.2	106	s 1.1	118	s 1.0	140	s 0.83	162	s 0.73	72	s 0.29	195	s 0.65		
350	82	s 1.8	91	s 1.5	101	s 1.4	120	s 1.1	139	s 1.0	61	s 0.37	167	s 0.84		
400	72	s 2.5	80	s 2.1	89	s 1.8	105	s 1.5	122	s 1.3	54	s 0.47	146	s 1.1		
500	58	s 4.4	64	s 3.6	71	s 3.1	84	s 2.4	97	s 2.0	43	s 0.74	117	s 1.6		
600	48	s 7.1	53	s 5.9	59	s 5.0	70	s 3.8	81	s 3.1	36	s 1.1	98	s 2.4		

Uniformly distributed load values under conditions different from the basic ones ($\gamma_q=1.2$; $\gamma_m=1.2$; $k_{mod}=0.70$), are calculated by multiplying tabulated values by a correction factor $k_{load,corr}$, given by

$$k_{load,corr} = \frac{k_{mod}}{\gamma_m \gamma_q} \frac{1.2 \times 1.2}{0.70} \quad [5.15].$$

Plywood deflection values under conditions different from the basic ones ($k_{def}=2.5$; $\psi_2=0.2$), are calculated by multiplying tabulated values by a correction factor $k_{def,corr}$, given by

$$k_{def,corr} = \frac{1 + \psi_2 k_{def}}{1 + 0.5} k_{load,corr} \quad [5.16].$$

Table 5.10. Uniformly distributed load resistance on a sanded continuous plate strip with three equal span lengths. Face grain parallel to studs

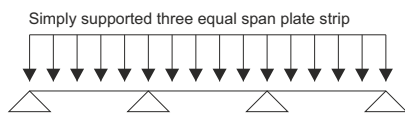

Service Class 1
 $K_{mod}=0.7$ $\psi_2=0.2$ $\gamma_m=1.2$
 $K_{def}=2.5$ $\Gamma_q=1.2$

Span c/c mm	Uniformly distributed load q (kN/m ²) and deflection u (mm)													
	Nominal thickness (mm)													
	4		6.5		9		12		15		18		21	
	q	u	q	u	q	u	q	u	q	u	q	u	q	u
100	-	-	54 s 0.70	103 s 0.45	127 s 0.29	168 s 0.25	196 s 0.22	234 s 0.20						
150	-	-	36 s 2.0	69 s 1.2	85 s 0.69	112 s 0.54	131 s 0.43	156 s 0.39						
200	-	-	27 s 4.5	51 s 2.5	64 s 1.4	84 s 1.0	98 s 0.78	117 s 0.67						
250	-	-	18 b 7.0	40 b 4.5	51 s 2.5	67 s 1.8	78 s 1.3	93 s 1.1						
300	-	-	12 b 10	28 b 6.2	42 s 4.0	56 s 2.8	65 s 2.0	78 s 1.7						
350	-	-	9.0 b 13	21 b 8.3	36 b 6.2	48 s 4.3	56 s 3.1	67 s 1.24						
400	-	-	6.9 b 17	16 b 10.7	28 b 7.9	42 s 6.2	49 s 4.4	58 s 3.4						
500	-	-	4.4 b 27	10 b 16.4	18 b 12	27 b 9.6	39 b 8.0	47 s 6.2						
600	-	-	3.1 b 39	7.0 b 23.5	12 b 17	19 b 13	27 b 11	37 b 9.8						
	24		27		30		35		40		45		50	
	q	u	q	u	q	u	q	u	q	u	q	u	q	u
100	263 s 0.19	301 s 0.19	330 s 0.18	398 s 0.17	465 s 0.17	518 s 0.16	567 s 0.16							
150	175 s 0.35	200 s 0.33	220 s 0.30	265 s 0.28	310 s 0.27	345 s 0.25	378 s 0.26							
200	132 s 0.58	150 s 0.53	165 s 0.48	199 s 0.43	232 s 0.40	259 s 0.37	284 s 0.37							
250	105 s 0.90	120 s 0.81	132 s 0.72	159 s 0.62	186 s 0.56	207 s 0.51	227 s 0.51							
300	88 s 1.4	100 s 1.2	110 s 1.0	133 s 0.86	155 s 0.76	173 s 0.68	189 s 0.67							
350	75 s 2.0	86 s 1.7	94 s 1.4	114 s 1.2	133 s 1.0	148 s 0.89	162 s 0.86							
400	66 s 2.7	75 s 2.3	82 s 2.0	99 s 1.6	116 s 1.3	130 s 1.2	142 s 1.1							
500	53 s 4.9	60 s 4.1	66 s 3.4	80 s 2.6	93 s 2.1	104 s 1.8	113 s 1.7							
600	44 s 8.0	50 s 6.6	55 s 5.4	66 s 4.1	77 s 3.2	86 s 2.8	95 s 2.5							

5.5. Concentrated load

For a concentrated load over an area of 80×180 mm or 50×50 mm on a continuous plate strip with equal span lengths the critical bending stress is given by

$$\sigma = \frac{M_{cri}}{W} = \alpha \frac{F}{W} \quad [5.17],$$

where: F - the concentrated load, N;
 W - the section modulus of the full cross - section of the plate strip, ($= t^2/6$), mm³;
 t - the thickness of the plate strip, mm;
 α - factor is given in Table 5.11.

The critical shear stress τ is given by

$$\tau = \frac{3}{2} \frac{V_{cri}}{A} = \frac{3}{2} \beta \frac{Fb}{A} \quad [5.18],$$





where: A - ($= 2t(180 + 80)$) or ($= 2t(50 + 50)$) is the punched shear area, mm²;
 β - factor is given in Table 5.11.

The critical deflection u_{M+V} is given by

$$u_{M+V} \approx u_M = \varphi \frac{FL^2_{span} b}{EI} \quad [5.19],$$

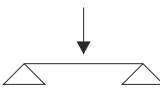
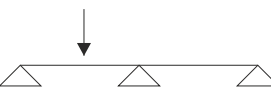
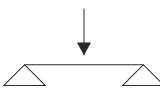
where: I - ($= t^3/12$) is the second moment of plane area of the full cross-section of the plate strip, mm⁴ [5.19];
 E - the modulus of elasticity, N/mm²;
 φ - factor is given in Table 5.11.

Table 5.11. α , β and φ factors to be used in equations [5.17] - [5.19.]

Number of spans		α	β	φ
	Strip	0.176	0.855	0.0148
		-	-	-
	Strip	0.481	1.061	0.0217
		-	-	-
	Plate	0.152	0.876	0.0115
		-	-	-
	Plate	0.486	1.360	0.0158
		-	-	-
	Plate	0.123	0.851	0.0093
		-	-	-
	Plate	0.436	1.026	0.0217
		-	-	-

5.6. Concentrated load over an area of 50×50 mm

The object of this section is to present and document tabulated concentrated load resistance values for concrete formworks of birch plywood Riga Ply produced by Latvijas Finieris. The calculation is carried out in accordance with VTT research protocol RTE 3969-04 and prEN 1995-1-1 Eurocode 5, Design of timber structures, Part 1:1 General - Common rules and rules for buildings.

Concentrated load values under conditions different from the basic ones ($\gamma_q=1.5$; $\gamma_m=1.2$; $k_{mod}=0.80$), are calculated by multiplying tabulated values by a correction factor $k_{load,corr}$, given by

$$k_{load,corr} = \frac{k_{mod}}{\gamma_m \gamma_q} \frac{1.2 \times 1.5}{0.80} \quad [5.20].$$

Plywood deflection values under conditions different from the basic ones ($k_{def}=0.8$; $\psi_2=0.3$), are calculated by multiplying tabulated values by a correction factor $k_{def,corr}$, given by

$$k_{def,corr} = \frac{1 + \psi_2 k_{def}}{1 + 0.24} k_{load,corr} \quad [5.21].$$

The load resistance values for: a concentrated load over an area of 50×50 mm on a single span plate strip; a concentrated load over an area of 50×50 mm on a double span plate strip; a concentrated load over an area of 50×50 mm on a simple supported plate given in Tables 5.12 - 5.14 are calculated according to the following assumptions: $\gamma_q=1.5$; $\gamma_m=1.2$; $k_{mod}=0.80$. Hence, the characteristic load acting in service classes 1 or 2 (dry or humid) and load duration class Medium - term (1 week to 6 months) shall not exceed the tabulated values. For other assumptions the tabulated load resistance values shall be multiplied by a correction factor $k_{load,corr}$ given by equation [5.20].

The deflection values given in Tables 5.12 - 5.14 are calculated according to the following assumptions: $k_{def}=0.8$; $\psi_2=0.3$; the load used is the tabulated load resistance assumed to be totally quasi-permanent. For other assumptions the tabulated deflection values shall be multiplied by a correction factor $k_{def,corr}$ given by equation [5.21].

Table 5.12. Load resistance for a concentrated load over an area of 50×50 mm on a sanded single span plate strip

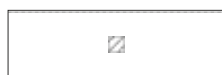

Simply supported
single span plate strip



Service Class 1

$$k_{mod}=0.8 \quad \psi_2=0.3 \quad \gamma_m=1.2$$

$$k_{def}=0.8 \quad \gamma_q=1.5$$

Span c/c mm	Concentrated load F (kN) and deflection u (mm)															
	Nominal thickness (mm)															
	4		6.5		9		12		15		18		21			
	F	u	F	u	F	u	F	u	F	u	F	u	F	u		
300	0.01 b	0.53	0.31 s	2.5	0.84 s	2.3	1.2 s	1.5	1.7 s	1.2	2.1 s	0.87	2.6 s	0.70		
400	0.01 b	0.82	0.27 s	3.9	0.79 b	4.0	1.2 s	2.7	1.7 s	2.1	2.1 s	1.6	2.6 s	1.3		
500	0.01 b	1.2	0.24 s	5.6	0.72 b	5.7	1.2 s	4.3	1.7 s	3.3	2.1 s	2.5	2.6 s	2.0		
600	0.01 b	1.5	0.23 s	7.5	0.67 b	7.7	1.2 s	6.2	1.7 s	4.8	2.1 s	3.6	2.6 s	2.8		
750	0.01 b	2.2	0.21 s	11	0.61 b	11	1.2 s	10	1.7 s	7.7	2.1 s	5.7	2.6 s	4.5		
1000	0.01 b	3.5	0.19 b	17	0.56 b	18	1.1 b	16	1.7 s	14	2.1 s	10	2.6 s	8.0		
1200	0.01 b	4.8	0.18 b	24	0.52 b	24	1.0 b	22	1.7 b	20	2.1 s	15	2.6 s	11		
1500	0.01 b	6.9	0.16 b	35	0.49 b	36	1.0 b	33	1.6 b	29	2.1 s	23	2.6 s	18		

	24		27		30		35		40		45		50	
	F	u	F	u	F	u	F	u	F	u	F	u	F	u
300	3.0 s	0.55	3.5 s	0.46	3.9 s	0.38	4.8 s	0.28	5.7 s	0.21	2.7 s	0.07	7.1 s	0.15
400	3.0 s	1.0	3.5 s	0.83	3.9 s	0.68	4.8 s	0.50	5.7 s	0.38	2.7 s	0.14	7.1 s	0.27
500	3.0 s	1.6	3.5 s	1.3	3.9 s	1.1	4.8 s	0.78	5.7 s	0.59	2.7 s	0.21	7.1 s	0.42
600	3.0 s	2.3	3.5 s	1.9	3.9 s	1.5	4.8 s	1.1	5.7 s	2.86	2.7 s	0.31	7.1 s	0.61
750	3.0 s	3.5	3.5 s	2.9	3.9 s	2.4	4.8 s	1.8	5.7 s	1.3	2.7 s	0.5	7.1 s	1.0
1000	3.0 s	6.3	3.5 s	5.3	3.9 s	4.3	4.8 s	3.2	5.7 s	2.4	2.7 s	0.9	7.1 s	1.7
1200	3.0 s	9.1	3.5 s	7.6	3.9 s	6.2	4.8 s	4.6	5.7 s	3.5	2.7 s	1.2	7.1 s	2.4
1500	3.0 s	14	3.5 s	12	3.9 s	10	4.8 s	7.1	5.7 s	5.4	2.7 s	1.9	7.1 s	3.8

Table 5.13. Load resistance for a concentrated load over an area of 50×50 mm on a sanded double span plate strip

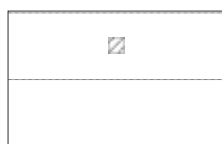

Simply supported
double span plate strip

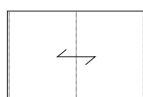

Service Class 1

$$k_{mod}=0.8 \quad \psi_2=0.3 \quad \gamma_m=1.2$$

$$k_{def}=0.8 \quad \gamma_q=1.5$$

Span c/c mm	Concentrated load F (kN) and deflection u (mm)															
	Nominal thickness (mm)															
	4		6.5		9		12		15		18		21			
	F	u	F	u	F	u	F	u	F	u	F	u	F	u		
300	0.01 b	0.46	0.33 s	2.1	0.84 s	1.9	1.2 s	1.2	1.7 s	0.95	2.1 s	0.70	2.6 s	0.56		
400	0.01 b	0.70	0.29 s	3.3	0.84 s	3.4	1.2 s	2.2	1.7 s	1.7	2.1 s	1.3	2.6 s	1.0		
500	0.01 b	1.0	0.26 s	4.7	0.76 b	4.8	1.2 s	3.5	1.7 s	2.7	2.1 s	2.0	2.6 s	1.6		
600	0.01 b	1.3	0.24 s	6.3	0.70 b	6.4	1.2 s	5.1	1.7 s	3.9	2.1 s	2.9	2.6 s	2.3		
750	0.01 b	1.9	0.22 s	9.1	0.64 b	9.2	1.2 s	8.0	1.7 s	6.1	2.1 s	4.5	2.6 s	3.6		
1000	0.01 b	3.0	0.20 b	15	0.58 b	15	1.1 b	14	1.7 s	11	2.1 s	8.0	2.6 s	6.4		
1200	0.01 b	4.0	0.18 b	20	0.55 b	20	1.1 b	18	1.7 s	16	2.1 s	12	2.6 s	9.3		
1500	0.01 b	5.8	0.17 b	29	0.51 b	30	1.0 b	27	1.7 s	24	2.1 s	18	2.6 s	14		

	24		27		30		35		40		45		50	
	F	u	F	u	F	u	F	u	F	u	F	u	F	u
300	3.0 s	0.44	3.5 s	0.37	3.9 s	0.30	4.7 s	0.22	5.4 s	0.16	2.4 s	0.05	6.6 s	0.11
400	3.0 s	0.80	3.5 s	0.66	3.9 s	0.55	4.7 s	0.39	5.4 s	0.29	2.4 s	0.09	6.6 s	0.20
500	3.0 s	1.3	3.5 s	1.0	3.9 s	0.89	4.7 s	0.61	5.4 s	0.45	2.4 s	0.15	6.6 s	0.31
600	3.0 s	1.8	3.5 s	1.5	3.9 s	1.2	4.7 s	0.89	5.4 s	0.66	2.4 s	0.22	6.6 s	0.45
750	3.0 s	2.9	3.5 s	2.4	3.9 s	2.0	4.7 s	1.4	5.4 s	1.0	2.4 s	0.34	6.6 s	0.71
1000	3.0 s	5.1	3.5 s	4.2	3.9 s	3.5	4.7 s	2.5	5.4 s	1.8	2.4 s	0.61	6.6 s	1.3
1200	3.0 s	7.3	3.5 s	6.1	3.9 s	5.0	4.7 s	3.6	5.4 s	2.7	2.4 s	0.87	6.6 s	1.8
1500	3.0 s	11	3.5 s	10	3.9 s	7.9	4.7 s	5.6	5.4 s	4.1	2.4 s	1.4	6.6 s	2.8

Table 5.14. Load resistance for a concentrated load over an area of 50×50 mm on a sanded simple supported plate

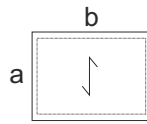
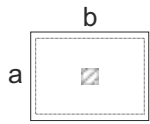

Service Class 1

$$k_{mod}=0.8 \quad \psi_2=0.3 \quad \gamma_m=1.2$$

$$k_{def}=0.8 \quad \gamma_q=1.5$$

Span c/c mm a×b	Concentrated load <i>F</i> (kN) and deflection <i>u</i> (mm)													
	Nominal thickness (mm)													
	4		6.5		9		12		15		18		21	
	q	u	q	u	q	u	q	u	q	u	q	u	q	u
300×300	-	-	0.29 s	1.9	0.82 b	1.8	1.2 s	1.1	1.7 s	0.86	2.1 s	0.63	2.5 s	0.50
300×600	-	-	0.31 s	2.5	0.82 s	2.3	1.2 s	1.5	1.7 s	1.1	2.1 s	0.85	2.5 s	0.68
300×900	-	-	0.31 s	2.5	0.82 s	2.3	1.2 s	1.5	1.7 s	1.2	2.1 s	0.86	2.5 s	0.69
300×∞	-	-	0.31 s	2.5	0.84 s	2.3	1.2 s	1.5	1.7 s	1.2	2.1 s	0.87	2.6 s	0.70
400×400	-	-	0.25 s	3.0	0.72 b	2.8	1.2 s	2.0	1.7 s	1.5	2.0 s	1.1	2.5 s	0.89
400×800	-	-	0.27 s	3.9	0.79 b	3.9	1.2 s	2.7	1.7 s	2.1	2.0 s	1.5	2.5 s	1.2
400×1200	-	-	0.27 s	3.9	0.79 b	4.0	1.2 s	2.7	1.7 s	2.1	2.0 s	1.5	2.5 s	1.2
400×∞	-	-	0.27 s	3.9	0.79 b	4.0	1.2 s	2.7	1.7 s	2.1	2.1 s	1.6	2.6 s	1.3
500×500	-	-	0.23 s	4.4	0.66 b	4.1	1.2 s	3.2	1.7 s	2.4	2.0 s	1.8	2.5 s	1.4
500×1000	-	-	0.24 s	5.6	0.71 b	5.6	1.2 s	4.2	1.7 s	3.2	2.0 s	2.4	2.5 s	1.9
500×1500	-	-	0.24 s	5.6	0.72 b	5.7	1.2 s	4.2	1.7 s	3.3	2.0 s	2.4	2.5 s	1.9
500×∞	-	-	0.24 s	5.6	0.72 b	5.7	1.2 s	4.3	1.7 s	3.3	2.1 s	2.5	2.6 s	2.0
600×600	-	-	0.21 s	5.9	0.62 b	5.5	1.2 s	4.6	1.7 s	3.5	2.0 s	2.6	2.5 s	2.0
600×1200	-	-	0.22 s	7.5	0.66 b	7.6	1.2 s	6.0	1.7 s	4.7	2.0 s	3.4	2.5 s	2.8
600×1800	-	-	0.23 s	7.5	0.67 b	7.7	1.2 s	6.1	1.7 s	4.7	2.0 s	3.5	2.5 s	2.8
600×∞	-	-	0.23 s	7.5	0.67 b	7.7	1.2 s	6.3	1.7 s	4.9	2.1 s	3.6	2.6 s	2.9
750×750	-	-	0.19 s	8.5	0.57 b	8.0	1.1 b	7.1	1.7 s	5.5	2.0 s	4.0	2.5 s	3.2
750×1500	-	-	0.21 s	11	0.61 b	11	1.2 s	10	1.7 s	7.3	2.0 s	5.4	2.5 s	4.3
750×2250	-	-	0.21 s	11	0.61 b	11	1.2 s	10	1.7 s	7.5	2.0 s	5.5	2.5 s	4.4
750×∞	-	-	0.21 s	11	0.61 b	11	1.2 s	10	1.7 s	7.7	2.1 s	5.7	2.6 s	4.6
1000×1000	-	-	0.18 b	14	0.52 b	13	1.0 b	12	1.7 s	10	2.1 s	7.3	2.6 s	5.8
1000×2000	-	-	0.19 b	17	0.55 b	18	1.1 b	16	1.7 s	13	2.1 s	10	2.6 s	7.8
1000×3000	-	-	0.19 b	17	0.56 b	18	1.1 b	16	1.7 s	13	2.1 s	10	2.6 s	7.9
1000×∞	-	-	0.19 b	17	0.56 b	18	1.1 b	16	1.8 b	15	2.1 s	10	2.6 s	7.9
1200×1200	-	-	0.17 b	19	0.49 b	18	1.0 b	16	1.6 b	14	2.3 s	11	2.9 s	9.4
1200×2400	-	-	0.18 b	24	0.52 b	24	1.0 b	22	1.7 s	19	2.1 s	14	2.6 s	11
1500×1500	-	-	0.16 b	28	0.46 b	26	0.91 b	23	1.5 b	20	2.1 s	17	2.6 s	13
1500×3000	-	-	0.16 b	34	0.49 b	35	1.0 b	32	1.6 b	29	2.1 s	22	2.6 s	18

Span c/c mm a×b	Concentrated load F (kN) and deflection u (mm)													
	Nominal thickness (mm)													
	24		27		30		35		40		45		50	
	q	u	q	u	q	u	q	u	q	u	q	u	q	u
300×300	3.0	s 0.39	3.4	s 0.32	3.8	s 0.27	4.7	s 0.19	5.6	s 0.15	2.8	s 0.05	7.0	s 0.10
300×600	2.9	s 0.54	3.4	s 0.45	3.8	s 0.37	4.7	s 0.27	5.6	s 0.20	2.7	s 0.07	7.0	s 0.14
300×900	2.9	s 0.55	3.4	s 0.45	3.8	s 0.38	4.7	s 0.27	5.6	s 0.21	2.7	s 0.07	7.0	s 0.15
300×∞	3.0	s 0.55	3.5	s 0.46	3.9	s 0.38	4.8	s 0.28	5.7	s 0.21	2.7	s 0.07	7.1	s 0.15
400×400	2.9	s 0.70	3.4	s 0.58	3.8	s 0.48	4.7	s 0.35	5.6	s 0.26	2.8	s 0.10	7.0	s 0.18
400×800	2.9	s 1.0	3.4	s 0.80	3.8	s 0.66	4.7	s 0.48	5.6	s 0.36	2.7	s 0.13	7.0	s 0.26
400×1200	2.9	s 1.0	3.4	s 0.81	3.8	s 0.67	4.7	s 0.49	5.6	s 0.37	2.7	s 0.13	7.0	s 0.26
400×∞	3.0	s 1.0	3.5	s 0.83	3.9	s 0.68	4.8	s 0.50	5.7	s 0.38	2.7	s 0.13	7.1	s 0.27
500×500	2.9	s 1.1	3.4	s 0.91	3.8	s 0.75	4.7	s 0.54	5.6	s 0.41	2.8	s 0.15	7.0	s 0.29
500×1000	2.9	s 1.5	3.4	s 1.3	3.8	s 1.0	4.7	s 0.76	5.6	s 0.57	2.7	s 0.21	7.0	s 0.40
500×1500	2.9	s 1.5	3.4	s 1.3	3.8	s 1.1	4.7	s 0.77	5.6	s 0.58	2.7	s 0.21	6.9	s 0.41
500×∞	3.0	s 1.6	3.5	s 1.3	3.9	s 1.1	4.8	s 0.79	5.7	s 0.60	2.7	s 0.21	7.1	s 0.42
600×600	2.9	s 1.6	3.4	s 1.3	3.8	s 1.1	4.7	s 0.79	5.6	s 0.60	2.8	s 0.22	7.0	s 0.42
600×1200	2.9	s 2.2	3.4	s 1.8	3.8	s 1.5	4.7	s 1.1	5.6	s 0.83	2.7	s 0.30	7.0	s 0.59
600×1800	2.9	s 2.2	3.4	s 1.9	3.8	s 1.5	4.7	s 1.1	5.6	s 0.85	2.7	s 0.31	7.0	s 0.60
600×∞	3.0	s 2.3	3.5	s 1.9	3.9	s 1.6	4.8	s 1.1	5.7	s 0.87	2.7	s 0.31	7.1	s 0.61
750×750	2.9	s 2.5	3.4	s 2.1	3.8	s 1.7	4.7	s 1.2	5.6	s 0.94	2.7	s 0.34	7.0	s 0.66
750×1500	2.9	s 3.4	3.4	s 2.9	3.8	s 2.4	4.7	s 1.7	5.6	s 1.3	2.7	s 0.47	7.0	s 0.92
750×2250	2.9	s 3.5	3.4	s 2.9	3.8	s 2.4	4.7	s 1.8	5.6	s 1.3	2.7	s 0.48	7.0	s 0.94
750×∞	3.0	s 3.6	3.5	s 3.0	3.9	s 2.5	4.9	s 1.8	5.8	s 1.4	2.7	s 0.48	7.2	s 0.97
1000×1000	3.0	s 4.5	3.5	s 3.8	3.9	s 3.1	4.8	s 2.2	5.7	s 1.7	2.7	s 0.61	7.1	s 1.2
1000×2000	3.0	s 6.2	3.5	s 5.1	3.9	s 4.2	4.8	s 3.1	5.7	s 2.3	2.7	s 0.84	7.0	s 1.7
1000×3000	3.0	s 6.3	3.4	s 5.2	3.8	s 4.3	4.8	s 3.2	5.7	s 2.4	2.7	s 0.86	7.0	s 1.7
1000×∞	3.0	s 6.3	3.4	s 5.2	3.8	s 4.3	4.8	s 3.2	5.7	s 2.4	2.7	s 0.86	7.0	s 1.7
1200×1200	3.3	s 7.4	3.9	s 6.1	4.3	s 5.0	5.3	s 3.6	6.2	s 2.7	2.7	s 0.87	7.5	s 1.8
1200×2400	3.0	s 9.0	3.5	s 7.5	3.9	s 6.2	4.8	s 4.5	5.7	s 3.4	2.7	s 1.2	7.1	s 2.4
1500×1500	3.0	s 10	3.5	s 8.7	3.9	s 7.1	4.9	s 5.1	5.8	s 3.9	2.7	s 1.4	7.2	s 2.7
1500×3000	3.0	s 14	3.5	s 12	3.9	s 10	4.9	s 7.1	5.8	s 5.4	2.7	s 1.9	7.2	s 3.8

5.7. Concentrated load over an area of 80×180 mm

The object of this section is to present and document tabulated concentrated load resistance values for floors of birch plywood Riga Ply produced by Latvijas Finieris. The calculation is carried out in accordance with VTT research protocol RTE 3970-04 and prEN 1995-1-1 Eurocode 5.

The load resistance values for: a concentrated load over an area of 80×180 mm on a single span plate strip; a concentrated load over an area of 80×180 mm on a double span plate strip; a concentrated load over an area of 80×180 mm on a simple supported plate given in Tables 5.15 - 5.17 are calculated according to the following assumptions: $\gamma_q=1.0$; $\gamma_m=1.0$; $k_{mod}=0.90$. Hence, the characteristic load acting in service classes 1 or 2 (dry or humid) and load duration class Short - term (less than one week) shall not exceed the tabulated values. For other assumptions the tabulated load resistance values shall be multiplied by a correction factor $k_{load,corr}$ given by equation [5.22].

The deflection values given in Tables 5.15 - 5.17 are calculated according to the following assumptions: $k_{def}=1.0$; $\psi_2=0.0$; the load used is the tabulated load resistance assumed to be totally quasi-permanent. For other assumptions the tabulated deflection values shall be multiplied by a correction factor $k_{def,corr}$ given by equation [5.23].

Concentrated load values under conditions different from the basic ones ($\gamma_q=1.0$; $\gamma_m=1.0$; $k_{mod}=0.90$), are calculated by multiplying tabulated values by a correction factor $k_{load,corr}$ given by:

$$k_{load,corr} = \frac{k_{mod}}{\gamma_m \gamma_q} \frac{1.0 \times 1.0}{0.90} \quad [5.22].$$

Plywood deflection values under conditions different from the basic ones ($k_{def}=1.0$; $\psi_2=0.0$), are calculated by multiplying tabulated values by a correction factor $k_{def,corr}$ given by

$$k_{def,corr} = \frac{1 + \psi_2 k_{def}}{1 + 0.0} k_{load,corr} \quad [5.23].$$

Table 5.15. Load resistance for a concentrated load over an area of 80×180 mm on a sanded single span plate strip



Simply supported
single span plate strip



Service Class 1

$$k_{mod}=0.9 \quad \psi_2=0.0 \quad \gamma_m=1.0$$

$$k_{def}=1.0 \quad \gamma_q=1.0$$

Span c/c mm	Concentrated load F (kN) and deflection u (mm) Nominal thickness (mm)															
	4		6.5		9		12		15		18		21			
	F	u	F	u	F	u	F	u	F	u	F	u	F	u		
300	0.06 b	1.9	1.6 b	8.9	3.4 b	6.6	5.6 b	5.1	8.4 b	4.1	12 b	3.5	15 s	2.8		
400	0.04 b	2.7	1.2 b	13	3.0 b	11	4.9 b	8.4	7.3 b	6.8	10 b	5.7	14 b	4.9		
500	0.03 b	3.6	0.98 b	17	2.7 b	16	4.5 b	12	6.7 b	10	9.3 b	8.4	12 b	7.2		
600	0.03 b	4.6	0.86 b	22	2.5 b	22	4.1 b	17	6.2 b	14	8.6 b	11	12 b	10		
750	0.02 b	6.3	0.74 b	30	2.1 b	30	3.8 b	25	5.7 b	20	8.0 b	17	11 b	15		
1000	0.02 b	10	0.62 b	46	1.8 b	46	3.5 b	41	5.2 b	33	7.3 b	28	9.7 b	24		
1200	0.02 b	13	0.57 b	61	1.7 b	61	3.3 b	56	4.9 b	45	6.9 b	38	9.2 b	33		
1500	0.02 b	18	0.51 b	86	1.5 b	87	3.0 b	79	4.6 b	67	6.5 b	56	8.6 b	48		

Span c/c mm	24		27		30		35		40		45		50	
	F	u	F	u	F	u	F	u	F	u	F	u	F	u
300	17 s	2.2	19 s	1.8	21 s	1.5	25 s	1.0	29 s	0.76	13 s	0.25	35 s	0.52
400	17 s	4.3	19 s	3.4	21 s	2.8	25 s	2.0	29 s	1.5	13 s	0.48	35 s	1.0
500	16 b	6.3	19 s	5.5	21 s	4.5	25 s	3.2	30 s	2.4	13 s	0.78	36 s	1.6
500	16 b	6.3	19 s	5.5	21 s	4.5	25 s	3.2	30 s	2.4	13 s	0.78	36 s	1.6
600	15 b	8.7	18 b	7.7	22 s	6.7	26 s	4.7	30 s	3.5	13 s	1.1	36 s	2.4
750	14 b	13	17 b	11	21 b	10	26 s	7.5	30 s	5.5	13 s	1.8	36 s	3.8
1000	12 b	21	16 b	19	19 b	17	26 s	13	30 s	10	13 s	3.3	36 s	6.8
1200	12 b	29	15 b	26	18 b	23	25 b	19	30 s	14	13 s	4.8	36 s	10
1500	11 b	42	14 b	38	17 b	34	24 b	29	30 s	23	13 s	7.5	36 s	16

Table 5.16. Load resistance for a concentrated load over an area of 80×180 mm on a sanded double span plate strip

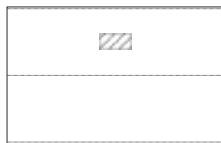

Simply supported
double span plate strip

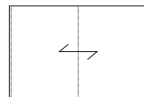

Service Class 1

$$k_{mod}=0.9 \quad \psi_2=0.0 \quad \gamma_m=1.0$$

$$k_{def}=1.0 \quad \gamma_q=1.0$$

Span c/c mm	Concentrated load F (kN) and deflection u (mm) Nominal thickness (mm)															
	4		6.5		9		12		15		18		21			
	F	u	F	u	F	u	F	u	F	u	F	u	F	u		
300	0.07 b	1.8	1.9 s	8.1	3.9 b	5.9	6.5 b	4.6	8.1 s	3.1	10 s	2.3	11 s	1.7		
400	0.05 b	2.5	1.4 b	11	3.3 b	10	5.6 b	7.5	8.3 b	6.1	11 s	4.7	12 s	3.4		
500	0.04 b	3.3	1.1 b	15	3.0 b	14	5.0 b	11	7.5 b	8.8	10 b	7.4	13 s	5.9		
600	0.03 b	4.1	0.94 b	19	2.7 b	19	4.6 b	15	6.9 b	12	9.6 b	10	13 b	8.7		
750	0.03 b	5.6	0.80 b	26	2.3 b	26	4.2 b	22	6.3 b	18	8.8 b	15	12 b	13		
1000	0.02 b	8.3	0.67 b	39	1.9 b	39	3.8 b	35	5.7 b	29	8.0 b	24	11 b	21		
1200	0.02 b	11	0.60 b	51	1.8 b	52	3.5 b	47	5.4 b	39	7.5 b	33	10 b	28		
1500	0.02 b	15	0.54 b	72	1.6 b	73	3.1 b	67	5.0 b	58	7.0 b	48	9.3 b	42		

Span c/c mm	24		27		30		35		40		45		50	
	F	u	F	u	F	u	F	u	F	u	F	u	F	u
300	13 s	1.3	14 s	1.0	16 s	0.9	19 s	0.60	22 s	0.45	10 s	0.15	27 s	0.31
400	14 s	2.7	16 s	2.2	17 s	1.8	21 s	1.3	24 s	0.93	11 s	0.31	29 s	0.64
500	14 s	4.4	16 s	3.5	17 s	2.9	21 s	2.0	24 s	1.5	11 s	0.52	29 s	1.0
600	14 s	6.5	16 s	5.2	17 s	4.2	21 s	3.0	24 s	2.2	11 s	0.77	29 s	1.5
750	14 s	10	16 s	8.2	17 s	6.8	21 s	4.8	24 s	3.5	11 s	1.2	29 s	2.4
1000	14 b	18	16 b	15	17 s	12	21 s	8.6	24 s	6.4	11 s	2.2	29 s	4.4
1200	13 b	25	16 b	22	17 s	18	21 s	12	24 s	9.2	11 s	3.2	29 s	6.3
1500	12 b	37	15 b	33	17 s	28	21 s	20	24 s	15	11 s	5.0	29 s	10

Table 5.17. Load resistance for a concentrated load over an area of 80×180 mm on a sanded simple supported plate

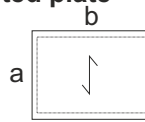
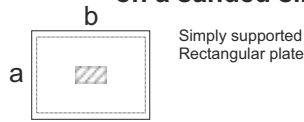

Service Class 1

$$k_{mod}=0.9 \quad \psi_2=0.0 \quad \gamma_m=1.0$$

$$k_{def}=1.0 \quad \gamma_q=1.0$$

Span c/c mm <i>a</i> × <i>b</i>	Concentrated load <i>F</i> (kN) and deflection <i>u</i> (mm)													
	Nominal thickness (mm)													
	4		6.5		9		12		15		18		21	
	<i>F</i>	<i>u</i>	<i>F</i>	<i>u</i>	<i>F</i>	<i>u</i>	<i>F</i>	<i>u</i>	<i>F</i>	<i>u</i>	<i>F</i>	<i>u</i>	<i>F</i>	<i>u</i>
300×300	-	-	1.3 b	5.5	3.6 b	5.0	6.8 b	4.3	11 s	3.7	13 s	2.6	17 s	2.1
300×600	-	-	1.6 b	8.8	3.5 b	6.6	5.7 b	5.1	8.5 b	4.1	12 b	3.4	15 s	2.8
300×900	-	-	1.6 b	8.9	3.4 b	6.6	5.6 b	5.1	8.4 b	4.1	12 b	3.5	15 s	2.8
300×∞	-	-	1.6 b	8.9	3.4 b	6.6	5.6 b	5.1	8.4 b	4.1	12 b	3.5	15 s	2.8
400×400	-	-	1.0 b	8.6	2.8 b	7.8	5.4 b	6.7	8.9 b	5.8	13 s	5.0	16 s	3.9
400×800	-	-	1.2 b	12	3.0 b	11	5.0 b	8.3	7.4 b	6.8	10 b	5.7	14 b	4.9
400×1200	-	-	1.2 b	13	3.0 b	11	4.9 b	8.4	7.3 b	6.8	10 b	5.7	14 b	4.9
400×∞	-	-	1.2 b	13	3.0 b	11	4.9 b	8.4	7.3 b	6.8	10 b	5.7	14 b	4.9
500×500	-	-	0.86 b	12	2.4 b	11	4.7 b	9.5	7.6 b	8.2	11 b	7.2	15 s	6.2
500×1000	-	-	0.98 b	17	2.7 b	16	4.5 b	12	6.7 b	10	9.4 b	8.3	13 b	7.2
500×1500	-	-	0.98 b	17	2.7 b	16	4.5 b	12	6.7 b	10	9.3 b	8.4	12 b	7.3
500×∞	-	-	0.98 b	17	2.7 b	16	4.5 b	12	6.7 b	10	9.3 b	8.4	12 b	7.3
600×600	-	-	0.76 b	16	2.1 b	14	4.2 b	13	6.8 b	11	10.1 b	10	14 b	8.5
600×1200	-	-	0.85 b	22	2.5 b	21	4.2 b	17	6.3 b	14	8.7 b	11	12 b	10
600×1800	-	-	0.86 b	22	2.5 b	22	4.1 b	17	6.2 b	14	8.6 b	11	12 b	10
600×∞	-	-	0.86 b	22	2.5 b	22	4.1 b	17	6.2 b	14	8.6 b	11	12 b	10
750×750	-	-	0.66 b	22	1.9 b	21	3.7 b	18	6.1 b	15	9.0 b	14	12 b	12
750×1500	-	-	0.73 b	30	2.1 b	30	3.9 b	25	5.8 b	20	8.1 b	17	11 b	14
750×2250	-	-	0.74 b	30	2.1 b	30	3.8 b	25	5.7 b	20	8.0 b	17	11 b	14
750×∞	-	-	0.74 b	30	2.1 b	30	3.8 b	25	5.7 b	20	8.0 b	17	11 b	15
1000×1000	-	-	0.57 b	35	1.6 b	32	3.2 b	28	5.3 b	25	7.8 b	22	11 b	19
1000×2000	-	-	0.62 b	45	1.8 b	45	3.5 b	40	5.3 b	33	7.3 b	27	9.8 b	24
1000×3000	-	-	0.62 b	46	1.8 b	46	3.5 b	41	5.2 b	33	7.3 b	28	9.7 b	24
1000×∞	-	-	0.62 b	46	1.8 b	46	3.5 b	41	5.2 b	33	7.3 b	28	9.7 b	24
1200×1200	-	-	0.52 b	46	1.5 b	43	3.0 b	38	4.9 b	33	7.2 b	29	10 b	26
1200×2400	-	-	0.57 b	60	1.7 b	60	3.3 b	54	5.0 b	45	6.9 b	38	9.3 b	32
1500×1500	-	-	0.47 b	66	1.4 b	62	2.7 b	54	4.4 b	47	6.6 b	42	9.2 b	37
1500×3000	-	-	0.51 b	85	1.5 b	86	3.0 b	77	4.7 b	66	6.5 b	55	8.7 b	48

Span c/c mm <i>a</i> × <i>b</i>	Concentrated load <i>F</i> (kN) and deflection <i>u</i> (mm) Nominal thickness (mm)													
	24		27		30		35		40		45		50	
	<i>F</i>	<i>u</i>	<i>F</i>	<i>u</i>	<i>F</i>	<i>u</i>	<i>F</i>	<i>u</i>	<i>F</i>	<i>u</i>	<i>F</i>	<i>u</i>	<i>F</i>	<i>u</i>
300×300	19	s 1.6	21	s 1.3	24	s 1.1	28	s 0.74	33	s 0.55	15	s 0.18	40	s 0.37
300×600	17	s 2.2	19	s 1.7	21	s 1.4	25	s 1.0	29	s 0.74	13	s 0.24	35	s 0.51
300×900	17	s 2.2	19	s 1.8	21	s 1.4	25	s 1.0	29	s 0.75	13	s 0.25	35	s 0.52
300×∞	17	s 2.2	19	s 1.8	21	s 1.4	25	s 1.0	29	s 0.76	13	s 0.25	35	s 0.52
400×400	18	s 3.1	20	s 2.5	23	s 2.0	27	s 1.4	32	s 1.0	14	s 0.34	38	s 0.71
400×800	17	s 4.2	19	s 3.3	21	s 2.7	25	s 1.9	29	s 1.4	13	s 0.47	36	s 0.97
400×1200	17	s 4.3	19	s 3.4	21	s 2.8	25	s 2.0	29	s 1.4	13	s 0.48	35	s 0.99
400×∞	17	s 4.3	19	s 3.4	21	s 2.8	25	s 2.0	29	s 1.5	13	s 0.48	35	s 0.99
500×500	17	s 4.9	20	s 4.0	22	s 3.2	27	s 2.3	31	s 1.7	14	s 0.55	37	s 1.1
500×1000	16	b 6.3	19	s 5.4	22	s 4.4	26	s 3.1	30	s 2.3	13	s 0.76	36	s 1.6
500×1500	16	b 6.3	19	s 5.5	21	s 4.5	25	s 3.2	30	s 2.4	13	s 0.77	36	s 1.6
500×∞	16	b 6.3	19	s 5.5	21	s 4.5	25	s 3.2	30	s 2.4	13	s 0.78	36	s 1.6
600×600	17	s 7.0	20	s 5.8	22	s 4.8	26	s 3.3	31	s 2.5	14	s 0.81	37	s 1.7
600×1200	15	b 8.6	19	b 7.7	22	s 6.5	26	s 4.6	30	s 3.4	13	s 1.1	36	s 2.3
600×1800	15	b 8.7	18	b 7.7	22	s 6.7	26	s 4.7	30	s 3.5	13	s 1.1	36	s 2.4
600×∞	15	b 8.7	18	b 7.7	22	s 6.7	26	s 4.7	30	s 3.5	13	s 1.1	36	s 2.4
750×750	17	b 11	20	s 9.1	22	s 7.5	26	s 5.3	30	s 3.9	13	s 1.3	37	s 2.7
750×1500	14	b 13	17	b 11	21	b 10	26	s 7.3	30	s 5.4	13	s 1.8	36	s 3.7
750×2250	14	b 13	17	b 11	21	b 10	26	s 7.5	30	s 5.5	13	s 1.8	36	s 3.8
750×∞	14	b 13	17	b 11	21	b 10	26	s 7.5	30	s 5.5	13	s 1.8	36	s 3.8
1000×1000	14	b 17	18	b 16	21	s 13	26	s 10	30	s 7.0	13	s 2.3	36	s 4.8
1000×2000	13	b 21	16	b 18	19	b 17	26	s 13	30	s 10	13	s 3.2	36	s 6.7
1000×3000	12	b 21	16	b 19	19	b 17	26	s 13	30	s 10	13	s 3.3	36	s 6.8
1000×∞	12	b 21	16	b 19	19	b 17	26	s 13	30	s 10	13	s 3.3	36	s 6.8
1200×1200	13	b 23	17	b 21	21	b 19	26	s 14	30	s 10	13	s 3.4	36	s 7.0
1200×2400	12	b 28	15	b 25	18	b 23	26	s 19	30	s 14	13	s 4.7	36	s 9.7
1500×1500	12	b 34	16	b 31	19	b 28	26	s 22	30	s 16	13	s 5.3	36	s 11
1500×3000	11	b 42	14	b 37	17	b 34	24	s 28	30	s 22	13	s 7.3	36	s 15





application

packaging, storage, acclimatisation, transport	6-1
machining	6-4
finishing	6-5
installation	6-5
main plywood applications	6-9

6.1. Packaging, storage, acclimatisation, transport

Proper storage and transportation of plywood during use and processing is very important. Analysis of customers' complaints concerning delivered goods indicates that many complaints are due to lack of information (improper storage, transportation and selection of processing technics). The aim of this section is to provide instructions for plywood products storage and transportation. The instructions are based on experience and ENV 12872.

6.1.1. Packaging

Latvijas Finieris for plywood packaging mainly uses plywood, cardboard or foil. Packs are strapped with plastic or metal straps; plastic or cardboard supporting brackets are used, so the straps do not damage plywood. Packaging should be disposed according to current legislation.

Figure 6.1. Standard size plywood packaging

Storage recommendation –
keep away from rain or damp conditions



Figure 6.2. Label on the packaging

Trade mark & product name	
Product details	Product compliance to specific requirements
Product size and information about the pack	
Identification number and barcode	

6.1.2. Storage

Selection of storage place is very important. Plywood must be stocked in a place well protected against rain and snow, with a good air circulation.

An appropriate store for plywood has a floor in concrete, or coated with other materials.

Plywood must not be stacked in direct contact with the floor, but on pallets or underlayers minimum 8 cm thick. This is mainly to avoid damages caused by drops of water, mud or other liquids, but also to avoid panels from absorbing moisture from the ground.

The panels are stacked horizontally on the pallets or underlayers, which are of equal height and lay on the same horizontal line.

A stack must be supported by at least 3 underlayers with a distance of about 800 mm, or on pallets.

When plywood packages or stacks are piled one on another, the intermediate underlayers must be at the same horizontal line, as shown in Figure 6.3

Figure 6.3. Properly and improperly made stacks of plywood panels



6.1.3. Acclimatisation

Plywood, as other wood materials, is hygroscopic i.e. a moisture absorbing material.

Moisture content variation causes swelling or shrinking of plywood.

To obtain good results in further processing it is therefore important that plywood is well acclimatised and reaches an equilibrium moisture content corresponding to the prevailing conditions at the further processing site.

An equilibrium moisture content is the one that plywood reaches under constant relative humidity and temperature of air, during a long time period.

Taking into account the above mentioned, there should be selected storage place with air parameters similar to parameters of final application place. Placing plywood for acclimatisation in stacks the height of stack shall be minimum to provide short time of acclimatisation. Examples of stacks are shown in Figure 6.4 and 6.5. In an ideal case, intermediate beams separate every panel in stack. Plywood in a tight stack absorbs or releases moisture uniformly through uncovered surfaces of the panels, i.e. only through the edges and the uncovered upper and bottom surfaces of the panels. If the stacked panels are separate with intermediate beams, all faces and sides of the panels are uncovered, thus allowing a constant and equal acclimatisation of all panels. This reduces significantly the required acclimatisation time. The time required for plywood acclimatisation depends on various factors - (1) the difference between equilibrium moisture content of plywood and the respective moisture content of the environment; (2) air flow; (3) thickness of the panels; (4) other factors. A panel has reached the equilibrium moisture content if its weight remains constant for 24 hours. The edges of the panels must not touch the floor or the wall (Figure 6.5).

When stocking plywood packs in a humid environment, packing straps (usually made of metal or plastic) must be opened, because straps may damage the edges of the panels due to swelling of the panels. Absorption or release of 1% of moisture, leads to the following alterations of the plywood panel dimensions: length 0.02%, width 0.02%, and thickness 0.3%.

6.1.4. Transport of panels

When taking a panel from a pack or a stack, it must be lifted, not pulled over surface of the bottom plate, because any hard particle (sand or film particle) between panels can lead to damage of processed or coated surface of the plywood panel.

The plywood packs should only be lifted by forklift from the underside and never via metal/plastic packing straps. The film faced plywood faces are very slippery, sliding panels may lead to the collapse of the whole stack.

Remember!

Plywood packs must be moved with a forklift.

The panels must be handled carefully, to avoid damages.

Separate sheets must be moved manually by two workers.

The panels must not be pulled or pushed on a floor or the ground.

Figure 6.4. **Stack of plywood for acclimatisation**

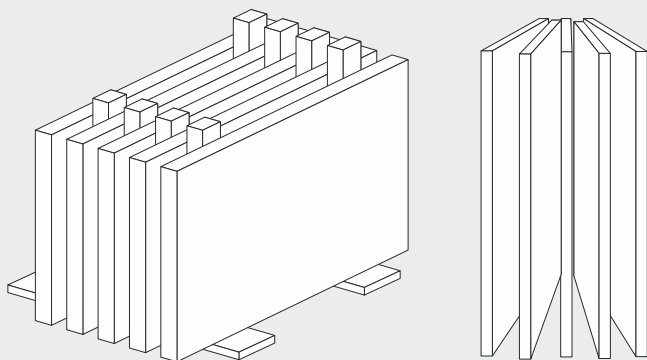
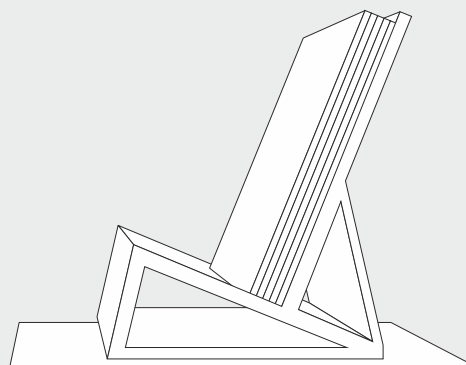

Figure 6.5. **Stack of plywood panels**



6.1.5. Loading and storage of packs at end user's premises

The earlier given instructions are to be followed. The best way of stocking plywood is in the original packs. They have to be protected against rain and snow; moving of packs must be done with a forklift. To avoid mechanical damages, the panels must be loaded and unloaded carefully. Each pack should be stacked separately.

6.1.6. Utilisation

Service life of both plywood and products made from plywood may vary significantly. For example, under conditions plywood in construction applications may serve over 50 years.

Plywood can be disposed of by burning, or placing it to a dump.

All plywood components do not combust at a low temperature, therefore it is recommended to use a high temperature furnace.

6.2. Machining

Plywood can be easily machined. It may be cut, drilled, and shaped manually or using machine tools. Consisting of several layers of veneer and glue, plywood is a hard material. Therefore it is recommended to use appropriate tools for plywood machining.

When cutting plywood it is recommended to saw in the opposite direction of the upper layer grain first and then in the grain direction thus avoiding the tearing of plywood upper layer at the panel corners.

To avoid tearing and to provide good quality surface, plywood must be machined in a horizontal position. Using double circular saw, chipping does not take place both on upper and on bottom side (see Figure 6.6). High rotating speed of blades and low feed speed are recommended for the best result.

For drilling, the plywood panels must be placed face up and appropriate wood processing tools are to be used. Drilling through must be done on a smooth support of the panel, in order to avoid damages on the panel's opposite side, where the drill blade comes out also hollow (instead of recess) of 45° can be made for screw sinking.

High speed of the milling cutter and low feed speed are recommended for plywood machining with milling equipment, similarly to sawing.

Depending on requirements to surface quality, it may be sanded both along the grain and across the grain using abrasive paper of different grade; usually it is No.80 or No.100.

Figure 6.6. **Cutting scheme**

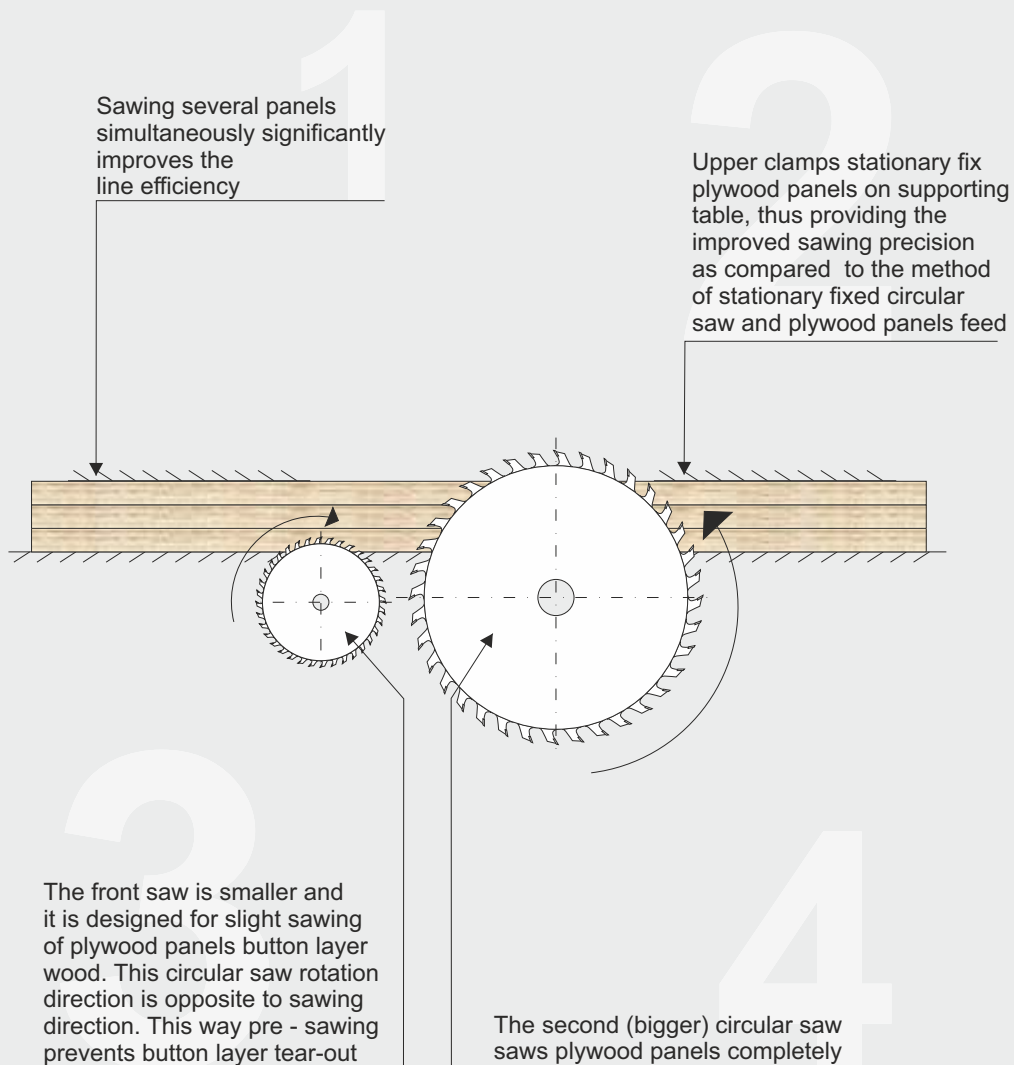

6.3. Finishing

Different types of plywood designed for finishing belong to the product range of Latvijas Finieris.

For staining or other finishing purposes, such as priming, varnishing or painting, Riga Ply has to be sanded with sanding paper of an appropriate grade.

If several layers of finish are applied, an interim sanding, with an appropriate grade of sanding paper, is required before each application of the finishing material.

Riga Paint plywood is overlaid with special paper and is ready for primer and paint application. This kind of surface absorbs significantly less paint than raw plywood does.

Riga Preprime plywood is specially designed for painting, preparation of the surface for finishing is not required. Surface of this plywood is overlaid with paper impregnated with primer and is ready for painting. This layer makes painting work easier and provides significant saving of painting material. When painted, these panels can be used e. g. for exterior cladding, as the surface does not crack.

Riga Prime plywood may be varnished or painted, depending on the type of primer applied.

It provides significant saving of labor and painting material similarly to the above-mentioned plywood types.

Unfinished surface of plywood must be protected against blue stain and mould, with appropriate materials.

Broad range of finishing materials may be used for plywood finishing: UV curing primer, varnishes, or paints; water based finishing materials: polyurethane, nitrocellulose, alkyd acryl or acid curing and painting materials.

6.4. Jointing and installation of plywood

6.4.1. Gluing

Application of phenol type glues is recommended for plywood joints requiring resistance against moisture. Urea type adhesive or other types of glue fit for wood are recommended for joint not requiring resistance against moisture. It is recommended to use PVA dispersion adhesive to glue plywood together with plastic or metal, or glue of different type designed to glue such materials together. Before gluing, it is recommended to clean surfaces from dust, metal surfaces are to be degreased.

When gluing plywood to the material of different value of coefficient of temperature expansion, the glue that is able to compensate dimension alteration of material under the influence of temperature shall be used.

When selecting adhesive for gluing of different materials it is recommended to consult glue manufacturers.

Figure 6.7. Joint types

JOINTS WITH PLUGS AND GROOVES

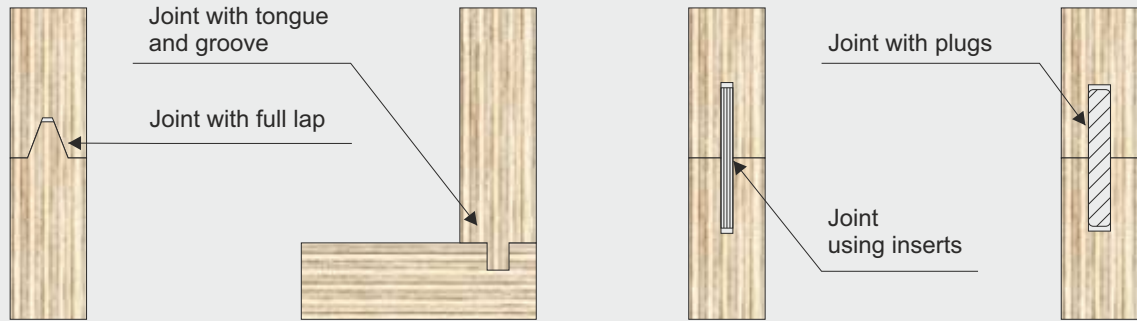

MECHANICAL JOINTS

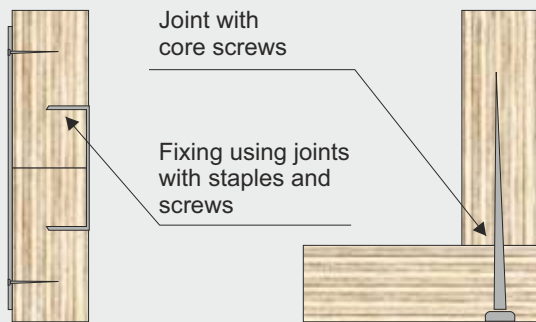

COMBINATED JOINTS

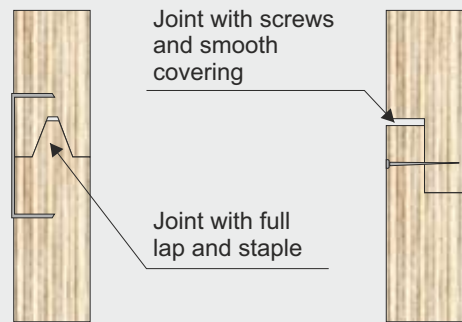

6.4.2. Joint types

The following solutions (see Figure 6.7) can be used for plywood jointing: (1) tongue and groove joints; (2) mechanical joints (bolts, rivets, clamps, wood screws and other joints); (3) combined joints. Adhesive selection depends on plywood type (exterior or interior applications). For tongue and groove joint reinforcement is recommended. Glue line provides higher joint resistance in comparison with joints of mechanical type. To protect groove against moisture, it should be filled with moisture resistant type filler or wax. Ends of grooves may be protected with water resistant protecting material (paint, filler).

Figure 6.8. Dimension alteration of 18 mm plywood panel overlaid with phenol film, in %, 2 cm from the edge, after immersion in water for 48 hours and drying

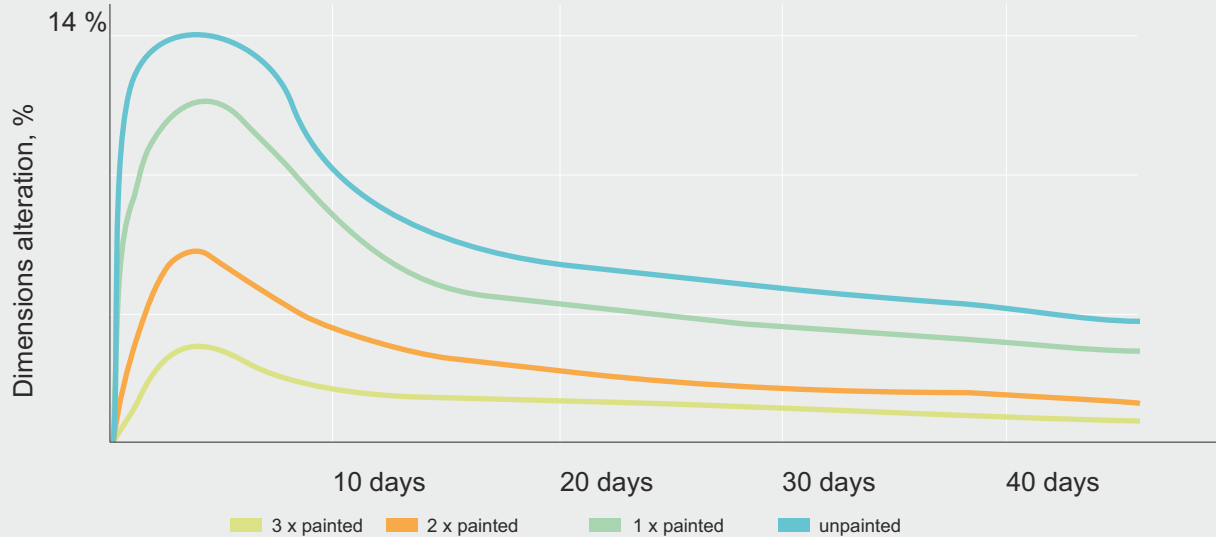
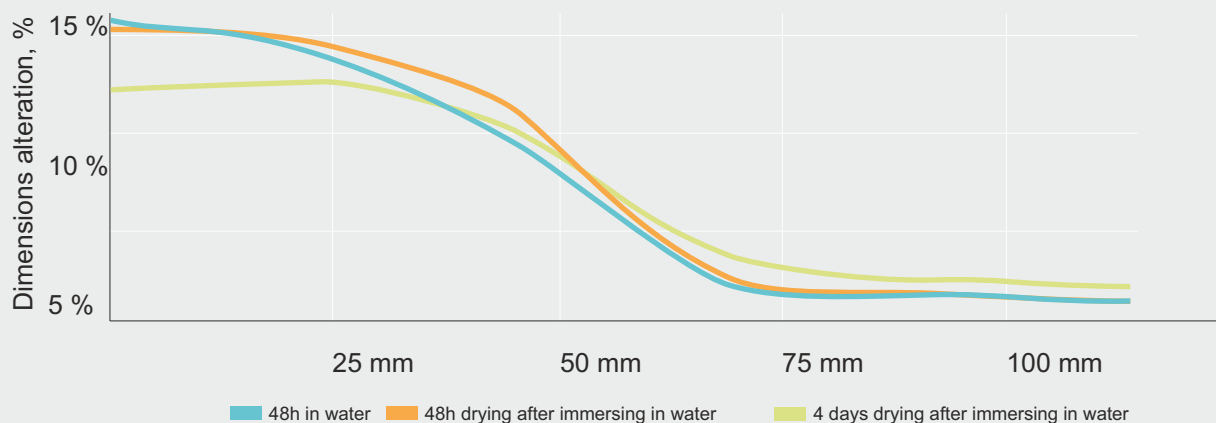

Figure 6.9. Dimension alteration



For mechanical joints it is necessary to make drilling before screw application. Hole diameter for bolt or rivet joint must be equal or slightly bigger than bolt or rivet diameter. The distance from plywood edge to the hole must be at least two times bigger than bolt or rivet head diameter. This protects the joint from deformation. The application of water resistant materials for protection against moisture is recommended. Applying bolt and rivet joints is recommended to avoid deforming of panels.

For wood screw the joint hole diameter must be less than the screw head diameter. This provides an easier plywood joint accomplishment. General recommendation concerning hole diameter is the following: hole diameter = 0.5*screw diameter.

Combined joints are recommended for tongue and groove joint reinforcement, applying metal or plastic straps on tongue and groove joint, thus decreasing possibility of warping.

6.4.3. Plywood edge sealing

It is necessary to protect the panel edges for outdoor applications against moisture using water resistant materials, coating edges with water resistant materials (paint, filler, etc.). Sealing may be accomplished by spraying several plywood boards in stack or sealing each panel individually, applying material by roller or brush. Edge sealing protects against water or moisture penetration via edges. Latvijas Finieris basically seals edges twice.

The Figure 6.8 shows variation of dimensions (in percents) of plywood (18 mm) overlaid with phenol film, 2 cm from the edge after immersion in water for 48 hours and drying. If the edges of a panel are not protected, the alteration value is up to three times bigger than when the edges are coated with water resistant paint.

Moisture content after the sample has been taken out of water continues to equalize in the direction to plywood center, the same time leading to edges shrivel (see Figure 6.9).

6.5. Main plywood applications

Latvijas Finieris manufactures plywood of different types. Each type is designed for specific applications. Each plywood product of Latvijas Finieris is marked by trademark **RIGA**

Main applications are listed in Table 6.1. It does not limit possibility of plywood use for other applications if plywood parameters meet requirements stated for material.



Table 6.2. **Recommended applications of Riga Ply, depending on grade**

Grade	Recommended application
B	High quality - transparent and semitransparent finishing of high quality, stain with preservative, varnishing.
S	Good quality - stain with preservative, varnishing or coating with transparent finishing materials.
BB	Standard grade (improved) - finishing by paint of interior applications and coating with different transparent and semitransparent laminates and films, as well as veneering. Building construction, painted or finished.
WGE	Plywood with no obvious defects, improved for coating with not transparent finishing materials (films, laminate).
WG	Application for building structures and packing when the outlook of upper plywood layer is not significant.
C	Application for building structures and packing when the outlook of upper plywood layer is not significant. Unsanded.

Table 6.1. Main plywood applications

Application	Riga Ply, Riga Ply AT	Riga Form	Riga Mel	Riga Tex	Riga Smooth Mesh	Riga Rhomb, Riga Rhomb Heavy	Riga Heksa, Riga Heksa Heavy	Riga Heksa Plus, Riga Heksa Plus Heavy	Riga Foot	Riga Trans, Riga Trans Heavy	Riga Crown	Riga Superwire	Riga Dot	Riga Frost	Riga Deck	Riga Force	Riga Paint	Riga Preprime	Riga Prime
Construction																			
Interior walls	●	●	●						●				●	●			●	●	●
External walls			●															●	
Inter-wall structures	●	●																	
Bins for agriculture products storage		●																	
Floor covering	●			●	●	●	●	●	●	●	●	●			●	●			
Parquet flooring blanks	●																		
Steps of stairs	●			●	●	●	●	●	●	●	●	●			●	●			
Bottom roof deck	●																		
Material of structures	●	●																	
Industrial floor				●	●	●	●	●	●	●	●	●			●	●			
Warehouse floor				●	●	●	●	●	●	●	●	●			●	●			
Scaffolding				●		●	●	●	●	●	●	●			●	●			
Trestles				●		●	●	●	●	●	●	●			●	●			
Platforms				●		●	●	●	●	●	●	●			●	●			
Pedestrian passes and bridges				●		●	●	●	●	●	●	●			●	●			
Children playgrounds		●			●	●	●	●	●	●	●	●	●	●	●	●	●	●	
Shuttering		●																	
Furniture manufacturing																			
Framework of cabinet furniture	●		●						●										●
Working surfaces	●		●						●										
Transport industry																			
Floor of trailer				●		●	●	●	●	●	●	●			●	●			
Floor of vans, buses				●		●	●	●	●	●	●	●			●	●			
Floor of container				●		●	●	●	●	●	●	●			●	●			
Lining of trailer walls and ceiling	●	●	●										●	●	●	●			
Isolation panels for LNG ships:																			
Packing																			
Packing (of high quality)		●			●	●	●	●	●	●	●	●	●	●	●	●			●
Packing (of low quality)	●																		
Other																			
Advertisement stands		●	●										●	●			●	●	●
Traffic signs and indicators		●		●															

Application	Riga Lacquer	Riga Color	Riga Decor	Riga Ignisafe	Riga 4Ships	Riga Prime FR	Riga Ship Ply	Riga Composite	Riga HPL	Riga Poliform	Riga Silent
Construction											
Interior walls	●	●	●	●	●	●			●		
External walls											
Inter-wall structures				●	●	●					
Bins for agriculture products storage					●						
Floor covering					●			●			
Parquet flooring blanks											
Steps of stairs					●						
Bottom roof deck				●		●					
Material of structures				●		●					
Industrial floor					●						●
Warehouse floor					●						
Scaffolding											
Trestles											
Platforms											
Pedestrian passes and bridges											
Children playgrounds									●		
Shuttering										●	
Furniture manufacturing											
Framework of cabinet furniture	●	●	●					●	●		
Working surfaces	●								●		
Transport industry											
Floor of trailer				●		●					●
Floor of vans, buses				●		●					●
Floor of container				●		●					
Lining of trailer walls and ceiling											
Isolation panels for LNG ships:							●				
Packing											
Packing (of high quality)					●						
Packing (of low quality)					●						
Other											
Advertisement stands								●			
Traffic signs and indicators											



literature

Products manufactured by Latvijas Finieris are in accordance with requirements of the following standards:

- EN 314-2 Plywood – Bonding quality – Part 2: Requirements
- EN 315 Plywood – Tolerances for dimensions

- EN 326-1 Wood-based panels – Sampling, cutting and inspection – Part 1: Sampling and cutting of test pieces and expression of test results
- EN 326-2 Wood-based panels – Sampling, cutting and inspection – Part 2: Quality control in the factory
- EN 326-3 Wood-based panels – Sampling, cutting and inspection – Part 3: Inspection of a consignment of panels
- EN 635-2 Plywood – Classification by surface appearance – Part 2: Hardwood
- EN 636 Plywood – Specifications
- EN 13501-1 Wood based panels for use in construction products and building elements – Part 1: Classification using data from reaction to fire tests
- EN 13986 Wood-based panels for use in construction – Characteristics, evaluation of conformity and marking
- SFS 2413 Quality requirements for appearance of plywood with outer plies of birch
- DIN 68705-3 Sperrholz - Bau-Furniersperrholz

Products manufactured by Latvijas Finieris are tested in accordance with procedures of the following standards:

- EN 310 Wood-based panels – Determination of modulus of elasticity in bending and of bending strength
- EN 314-1 Plywood – Bonding quality – Part 1: Test method
- EN 322 Wood-based panels – Determination of moisture content
- EN 323 Wood-based panels – Determination of density
- EN 324-1 Wood-based panels – Determination of dimensions of boards – Part 1: Determination of thickness, width and length
- EN 324-2 Wood-based panels – Determination of dimensions of boards – Part 2: Determination of squareness and edge straightness
- EN 325 Wood-based panels – Determination of dimensions of test pieces
- EN 438-2 Decorative high-pressure laminates (HPL) – Sheets based on thermosetting resins – Part 2: Determination of properties
- EN 635-5 Plywood - Classification by surface appearance – Parts 2: Hardwood
- EN ISO 717-1 Acoustics - Rating of sound insulation in buildings and of building elements - Part 1: Airborne sound insulation
- EN 717-2 Wood-based panels – Determination of formaldehyde release – Part 2: Formaldehyde release by the gas analysis method
- EN 789 Timber structures – Test methods – Determination of mechanical properties of wood based panels
- EN 1058 Wood-based panels – Determination of characteristic values of mechanical properties and density
- EN 1156 Wood-based panels – Determination of duration of load and creep factors
- EN 1818 Resilient floor coverings - Determination of the effect of loaded heavy duty castors

EN 1195	Timber structures - Test methods - Performance of structural floor decking
EN ISO 9239-1	Reaction to fire tests for floorings - Part 1: Determination of the burning behaviour using a radiant heat source
EN ISO 11925-2	Reaction to fire tests for floorings - Part 1: Determination of the burning impingement of flame - Part 2: Single-flame source test
EN 12871	Wood-based panels – Performance specifications and requirements for load bearing boards for use in floors, walls and roofs
EN 13823	Reaction to fire tests for building products - Building products excluding floorings exposed to the thermal attack by a single burning item
EN ISO 16000- 3	Indoor air - Part 3: Determination of formaldehyde and other carbonyl compounds - Active sampling method
Directive 95/28/EC	Burning behavior of materials used in interior construction of certain categories of motor vehicles
DIN 51130	Bestimmung der rutschhemmenden Eigenschaft
BGR 181	Merkblatt für Fußböden in Arbeitsräumen und Arbeitsbereichen mit Rutschgefahr (bisher ZH 1/571)

Other standards applying to plywood

EN 204	Classification of thermoplastic wood adhesives for non-structural applications.
EN 313-1	Plywood – Classification and Terminology – Part 1: Classification
EN 313-2	Plywood – Classification and Terminology – Part 2: Terminology
EN 335	Durability of wood and wood-based products – Use classes: definitions, application to solid wood and wood-based products.
EN 350-2	Durability of wood and wood-based products – Natural durability of solid wood – Part 2: Guide to natural durability and treatability of selected wood species of importance in Europa
EN 1099	Plywood - Biological durability - Guidance for the assessment of plywood for use in different hazard classes
ENV 1995-1-1	Eurocode 5 – Design of timber structures – Part 1-1: General rules and rules for buildings
EN 12369-2	Wood-based panels - Characteristic values for structural design - Part 2: Plywood
CEN/TS 12872	Wood-based panels – Guidance on the use of load bearing boards in floors, walls and roofs
EN 14272	Plywood – Calculation method for some mechanical properties

Please, visit European Standardisation Committee site <http://www.cenorm.be> or Latvian Standard site <http://www.lvs.lv> for actual information.



LATVIJAS
FINIERIS
GROUP

Bauskas iela 59, Rīga, LV 1004, Latvia
Phone +371 67627850; e-mail: info@finieris.lv; rigawood.com