

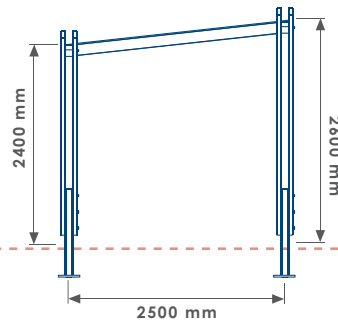

SPG320/B/TRC3/GL/1 BAY

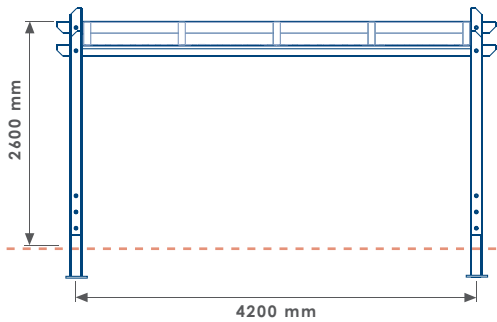

FINISHED GRADE

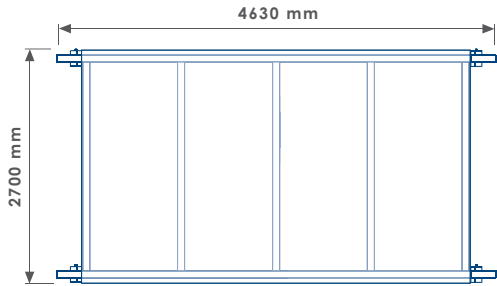
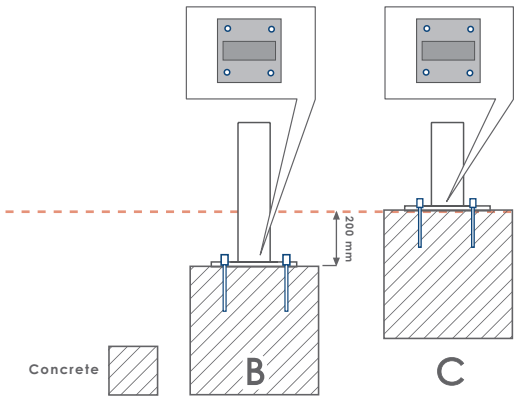

CODING METHOD				
PRODUCT CODE	FIXING METHOD	SLAT MATERIAL	METAL FINISH	NUMBER OF BAYS
SPG320	B	TRC3	GL	1

\* Technical drawings not to scale

**NOTE-**

- Site Engineer to determine suitable fixing method.
- Fixing bolts by others - 14 mm dia. holes (use M12 bolts).
- Size of concrete foundation and concrete mix to be determined on site, taking ground conditions into account and local wind and snow loads.
- Roof covering in Stucco profile aluminium sheet or 16 mm Multiwall polycarbonate as standard.

# SHELDON SHELTER SPG320

<b>PRODUCT DIMENSIONS</b>	<b>HEIGHT</b>	2600 mm	<b>LENGTH</b>	4630 mm	<b>WIDTH</b>	2700 mm	<b>WEIGHT</b>		<b>CAPACITY</b>		<b>SEAT HEIGHT</b>	
---------------------------	---------------	---------	---------------	---------	--------------	---------	---------------	--	-----------------	--	--------------------	--

FIXING OPTION	Direct Embedment/Root Fix	A
	Below Finished Grade Base Fix	B
	Surface Mount	C
	Plinth Mount - Buff Exposed Aggregate	D-BEA
	Plinth Mount - Buff Granite	D-BG
	Plinth Mount - Grey Granite	D-GG
	Free Standing	FS
	Free Standing with Base Weight	FS-BW
	Wall Mount	WM
	Non Standard	NS
To BREEAM Standard	B06/B08	

SLAT MATERIAL	Treated Redwood Class 3 Unstained	TRC3
	Treated Redwood Class 3 Stained Dark Oak	TRC3-DO
	Treated Redwood Class 4 Unstained	TRC4
	Treated Redwood Class 4 Stained Dark Oak	TRC4-DO
	Treated Softwood Unstained	TS
	Douglas Fir	DF
	FSC Hardwood Iroko	HI
	Recycled Plastic - Black	RP-BK
	Recycled Plastic - Grey	RP-GY
	Recycled Plastic - Green	RP-GN
Recycled Plastic - Brown	RP-BR	

METAL FINISH	Aluminium Powder Coated	APC
	Galvanised	GL
	Galvanised and Powder Coated	GPC
	Zinc Plated and Powder Coated	PPC
	Stainless Steel	SS-304/316
	Apex Top	AT
	Chamfer Top	CT
	Dome Top	DT
	Flat Top	FT
	Open Top	OT
Slant Top	ST	

CANOPY COLOUR	Black	502-8450	BK
	White	502-8102	WT
	Champagne	502-8341	CP
	Concrete	502-2167	CC
	Boulder	502-2171	BO
	Navy	502-1125	NV
	Midnight Blue	502-2161	MB
	Poppy	502-8255	PP
	Mandarin	502-8204	MA
	Buttercup	502-2166	BC
Tennis	502-8056	TN	



SPG320/B/TRC3/GL/8 BAYS

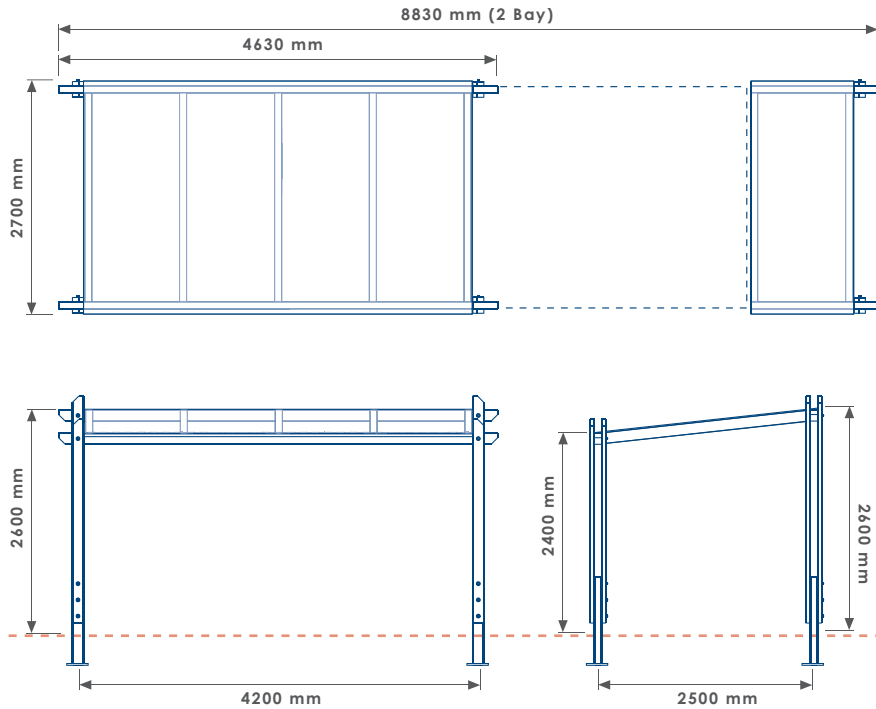

## CODING METHOD

PRODUCT CODE	FIXING METHOD	SLAT MATERIAL	METAL FINISH	NUMBER OF BAYS
SPG320	B	TRC3	GL	8

\* Technical drawings not to scale

### NOTE-

- Site Engineer to determine suitable fixing method.
- Fixing bolts by others - 14 mm dia. holes (use M12 bolts).
- Size of concrete foundation and concrete mix to be determined on site, taking ground conditions into account and local wind and snow loads.
- Roof covering in Stucco profile aluminium sheet or 16 mm Multiwall polycarbonate as standard.
- Image shown with upgraded roof specification.

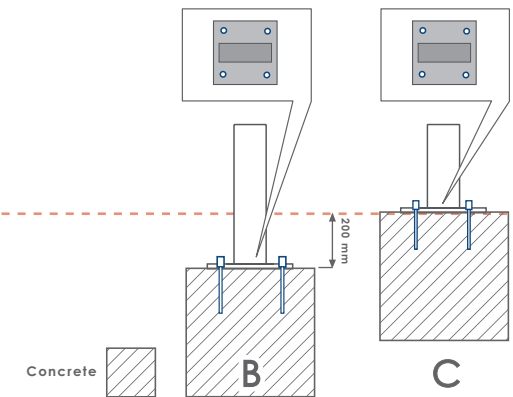

# SHELDON SHELTER SPG320

PRODUCT DIMENSIONS		HEIGHT	2600 mm	LENGTH	4630 mm	WIDTH	2700 mm	WEIGHT		CAPACITY		SEAT HEIGHT		
FIXING OPTION	Direct Embedment/Root Fix	A												
	Below Finished Grade Base Fix	B	<input checked="" type="checkbox"/>											
	Surface Mount	C	<input checked="" type="checkbox"/>											
	Plinth Mount - Buff Exposed Aggregate	D-BEA												
	Plinth Mount - Buff Granite	D-BG												
	Plinth Mount - Grey Granite	D-GG												
	Free Standing	FS												
	Free Standing with Base Weight	FS-BW												
	Wall Mount	WM												
	Non Standard	NS												
To BREEAM Standard	B06/B08													
SLAT MATERIAL	Treated Redwood Class 3 Unstained	TRC3	<input checked="" type="checkbox"/>											
	Treated Redwood Class 3 Stained Dark Oak	TRC3-DO	<input checked="" type="checkbox"/>											
	Treated Redwood Class 4 Unstained	TRC4	<input checked="" type="checkbox"/>											
	Treated Redwood Class 4 Stained Dark Oak	TRC4-DO	<input checked="" type="checkbox"/>											
	Treated Softwood Unstained	TS												
	Douglas Fir	DF	<input checked="" type="checkbox"/>											
	FSC Hardwood Iroko	HI	<input checked="" type="checkbox"/>											
	Recycled Plastic - Black	RP-BK												
	Recycled Plastic - Grey	RP-GY												
	Recycled Plastic - Green	RP-GN												
Recycled Plastic - Brown	RP-BR													
METAL FINISH	Aluminium Powder Coated	APC												
	Galvanised	GL	<input checked="" type="checkbox"/>											
	Galvanised and Powder Coated	GPC	<input checked="" type="checkbox"/>											
	Zinc Plated and Powder Coated	PPC												
	Stainless Steel	SS-304/316	<input checked="" type="checkbox"/>											
	TOP TYPE	Apex Top	AT											
		Chamfer Top	CT											
		Dome Top	DT											
		Flat Top	FT											
		Open Top	OT											
Slant Top		ST												
CANOPY COLOUR	Black	502-8450	<input checked="" type="checkbox"/>	BK										
	White	502-8102	<input checked="" type="checkbox"/>	WT										
	Champagne	502-8341	<input checked="" type="checkbox"/>	CP										
	Concrete	502-2167	<input checked="" type="checkbox"/>	CC										
	Boulder	502-2171	<input checked="" type="checkbox"/>	BO										
	Navy	502-1125	<input checked="" type="checkbox"/>	NV										
	Midnight Blue	502-2161	<input checked="" type="checkbox"/>	MB										
	Poppy	502-8255	<input checked="" type="checkbox"/>	PP										
	Mandarin	502-8204	<input checked="" type="checkbox"/>	MA										
	Buttercup	502-2166	<input checked="" type="checkbox"/>	BC										
Tennis	502-8056	<input checked="" type="checkbox"/>	TN											