

FST224 Wobble + Step



A dual device with on one side the Helix, and on the other the Step. The Helix is an unsteady surface for balance exercises, excellent for improving the muscles in the ankle, knee and torso. The Step is probably the simplest and most versatile device in the Standing-Strong range; so many practical exercises can be done with a step.

Product Line	Outdoor Fitness
Category	Circuit Training
Age group	13+
Max. fall height (CM)	29
Total height (CM)	147
Safety Zone	14.3 m ²



**SUR-
FACE**

**IN-
GROU.**



ASTM

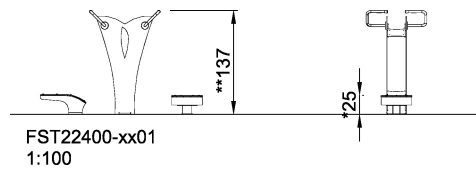
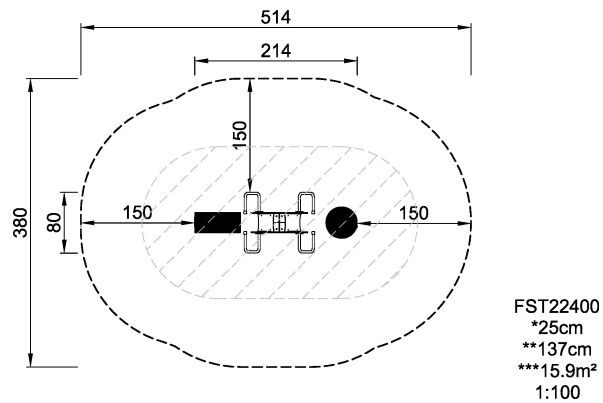

* = Highest designated play surface.
** = Total height of product.

Weight/heaviest parts	kg.	Installation (Manpower)	1 Persons
Concrete required	NaN m ³	Installation (Hours)	2 Hours
Foundation amount/footing	NaN	Excavation	NaN m ³