

FST220 Twist + Step

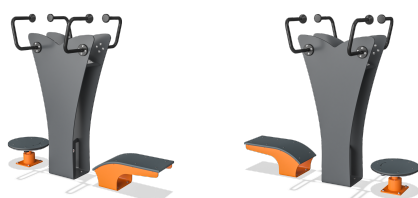

A dual device with on one side the Twist, and on the other the Step. The Twist mainly improves the strength of the muscles in the torso, and is excellent for lumbar mobility. The Step is probably the simplest and most versatile device in the Standing-Strong range; so many practical exercises can be done with a step.

Product Line	Outdoor Fitness
Category	Circuit Training
Age group	13+
Max. fall height (CM)	27
Total height (CM)	147
Safety Zone	14.3 m ²



**SUR-
FACE**

**IN-
GROU.**



ASTM

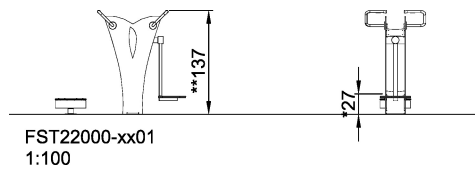
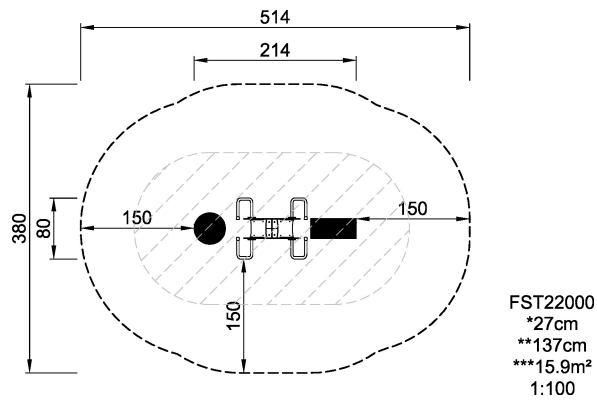

* = Highest designated play surface.
** = Total height of product.

Weight/heaviest parts	kg.	Installation (Manpower)	1 Persons
Concrete required	NaN m ³	Installation (Hours)	2 Hours
Foundation amount/footing	NaN	Excavation	NaN m ³