

# FAZ10100 Suspension Trainer

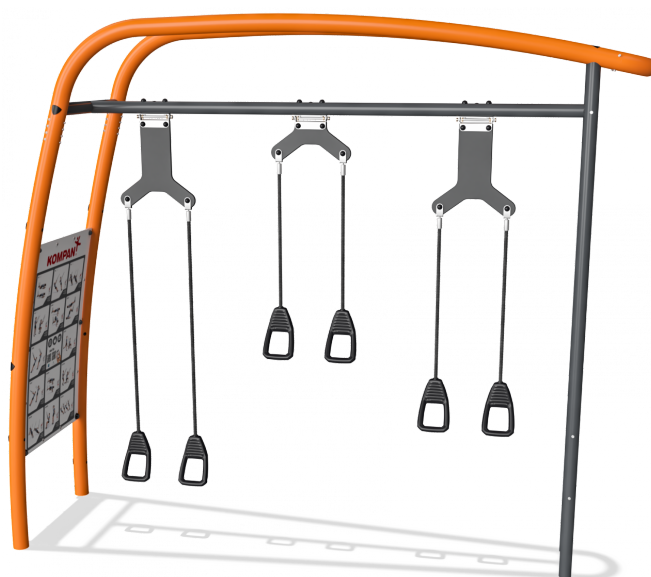

Three suspension trainers hanging at varying heights for highly versatile and accessible own bodyweight training. Using gravity and body position hundreds of exercises can be performed according to individual fitness levels and abilities. The intensity of each exercise can be determined simply by adjusting the body position to add more or less resistance. Suspension training is very effective because it simultaneously increases strength, balance, flexibility and core stability.

<b>Product Line</b>	Outdoor Fitness
<b>Category</b>	Cross Training
<b>Age group</b>	13+
<b>Total height (CM)</b>	334
<b>Safety Zone</b>	26.5 m <sup>2</sup>



**SUR-  
FACE**    **IN-  
GROU.**

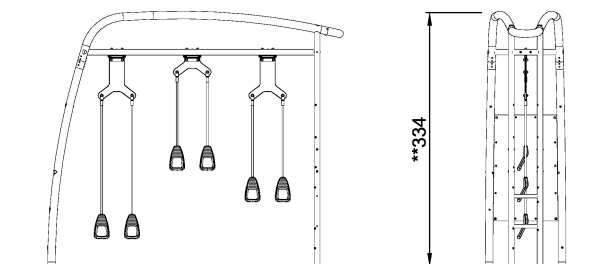
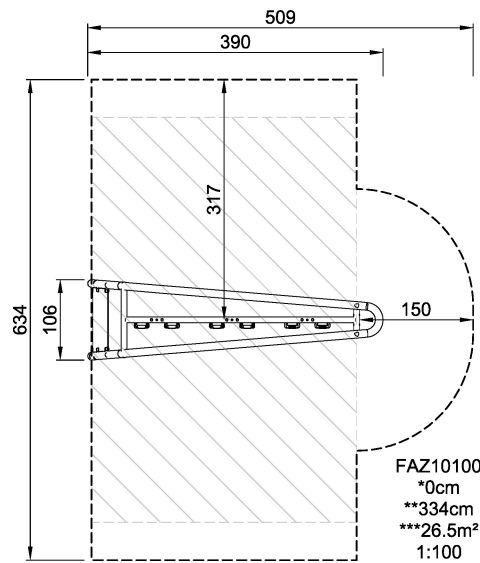

FAZ10100-xx00  
1:100

\* = Highest designated play surface.  
\*\* = Total height of product.

<b>Weight/heaviest parts</b>	kg.	<b>Installation (Manpower)</b>	1 Persons
<b>Concrete required</b>	NaN m <sup>3</sup>	<b>Installation (Hours)</b>	11 Hours
<b>Foundation amount/footing</b>	NaN	<b>Excavation</b>	NaN m <sup>3</sup>