

FST225

Step + Swing



The FST 225 is a dual device with on one side the Step, and on the other the Swing. Both the Step and the Swing have handles that offer optional support to the user. Performing exercises without holding on to the handles, will improve the user's balance. The Step is probably the simplest and most versatile device in the Standing-Strong range; so many practical exercises can be done with a step. The Swing improves the muscles in the torso, and additionally improves the coordination and flexibility of the hip area.

Product Line	Outdoor Fitness
Category	Circuit Training
Age group	13+
Max. fall height (CM)	72
Total height (CM)	147
Safety Zone	14.6 m ²



**SUR-
FACE**

**IN-
GROU.**



ASTM

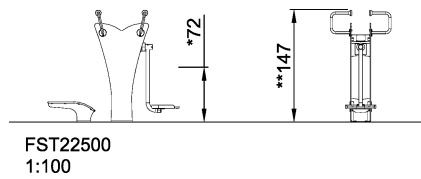
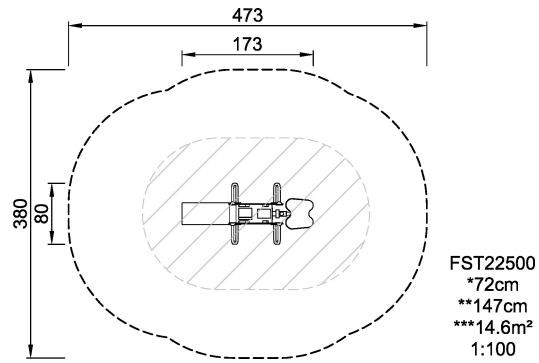

* = Highest designated play surface.
** = Total height of product.

Weight/heaviest parts	kg.	Installation (Manpower)	1 Persons
Concrete required	NaN m ³	Installation (Hours)	2 Hours
Foundation amount/footing	NaN	Excavation	NaN m ³