

FAZ30200

Step, 40 cm



The step is one of the most simple yet highly versatile training tools, so many exercises can be done with it, from simple step ups to plyometric jumps. Regular sessions will provide both cardiovascular and muscular endurance. Incorporating upper and lower body movements will improve balance and agility, and the constant push up onto the step will increase leg strength.

Product Line	Outdoor Fitness
Category	Cross Training
Age group	13+
Max. fall height (CM)	39
Total height (CM)	39
Safety Zone	10.4 m ²



**SUR-
FACE**

**IN-
GROU.**



ASTM

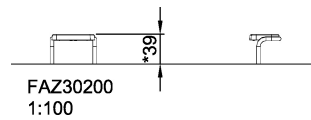
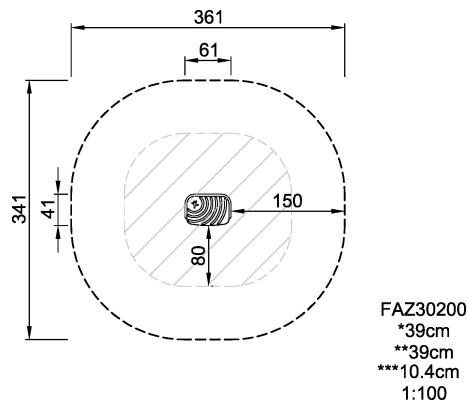

* = Highest designated play surface.
** = Total height of product.

Weight/heaviest parts	kg.	Installation (Manpower)	1 Persons
Concrete required	NaN m3	Installation (Hours)	1 Hours
Foundation amount/footing	NaN	Excavation	NaN m3