

FST103

Squat + Shoulder Press + Lat Pull Down



Resistance adjustable training device, designed for the execution of squats, lat pull downs and shoulder presses from a standing position. Squats train a large number of muscles in the legs and torso, and are good for the heart and blood vessels. Lat pull downs are excellent for training all back muscles, and biceps and chest muscles. The shoulder press trains the deltoid muscles, trapezius muscles, serratus anterior muscles and triceps.

Product Line	Outdoor Fitness
Category	Circuit Training
Age group	13+
Total height (CM)	145
Safety Zone	16 m ²



**SUR-
FACE**

**IN-
GROU.**



ASTM

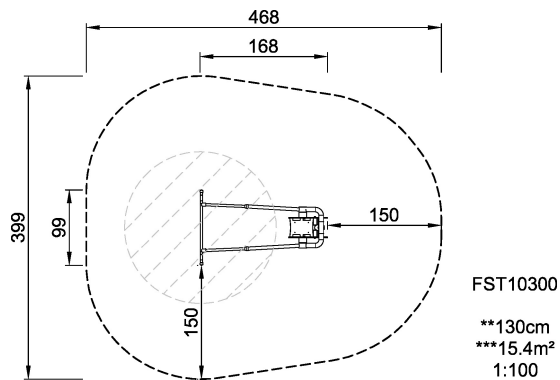

* = Highest designated play surface.
** = Total height of product.

Weight/heaviest parts	kg.	Installation (Manpower)	1 Persons
Concrete required	NaN m ³	Installation (Hours)	2 Hours
Foundation amount/footing	NaN	Excavation	NaN m ³