

FSW21800

Square Pull Up Station



The Square Pull Up Station can be used in many ways and by multiple users at the same time. Exercises range from normal pull ups to the most dynamic and advanced exercises such as the Flying Monkey, where you fly from one bar to another. These are just two out of the more than 20 exercises that can be found in the KOMPAN Sport & Fitness app.

Product Line	Sport & Fitness
Category	Obstacle Courses
Age group	13+
Max. fall height (CM)	133
Total height (CM)	240
Safety Zone	18.5 m ²



**SUR-
FACE**

**IN-
GROU.**



ASTM

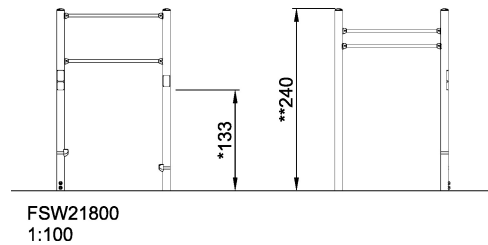
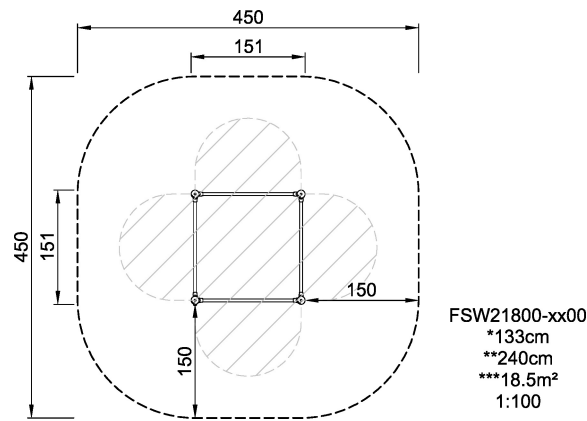

* = Highest designated play surface.
** = Total height of product.

Weight/heaviest parts	kg.	Installation (Manpower)	1 Persons
Concrete required	NaN m ³	Installation (Hours)	2 Hours
Foundation amount/footing	NaN	Excavation	NaN m ³