

FSW20900 Push Up Bars

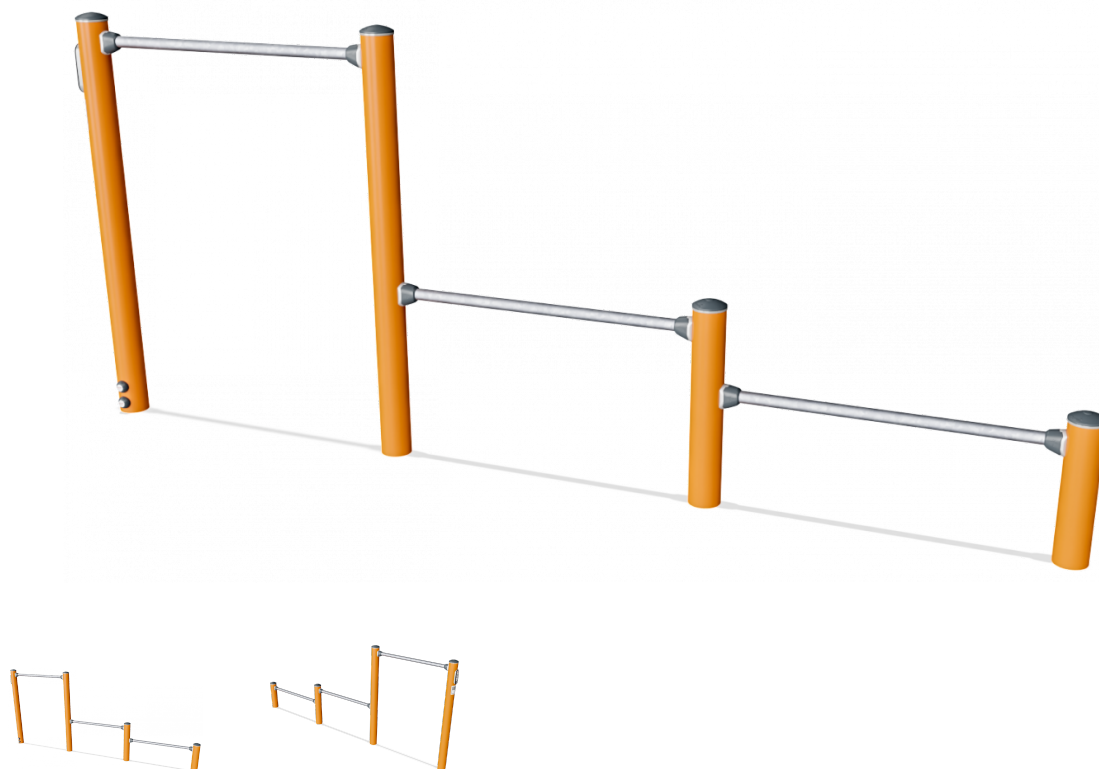

The push up bars are specifically designed for upper body training. The chest and arms can be trained through exercises such as rows or dips. To increase jumping skills and explosivity the bars can be used as hurdles for plyometric training. Additionally the bars can be used to climb under through.

Product Line	Outdoor Fitness
Category	Street Workout & Calisthenics
Age group	13+
Max. fall height (CM)	133
Total height (CM)	140
Safety Zone	18 m2



**SUR-
FACE**

**IN-
GROU.**



ASTM

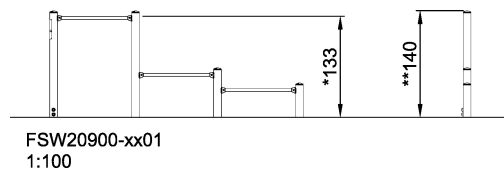
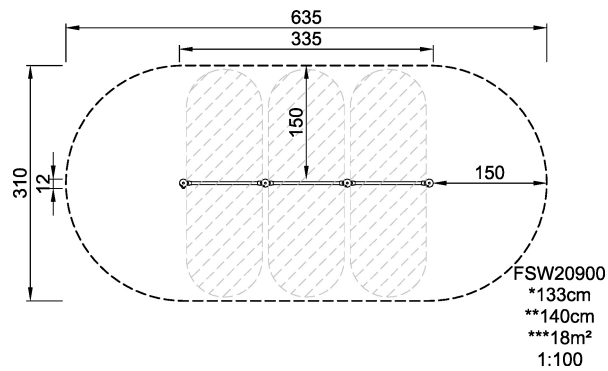

* = Highest designated play surface.
** = Total height of product.

Weight/heaviest parts	kg.	Installation (Manpower)	1 Persons
Concrete required	NaN m ³	Installation (Hours)	2 Hours
Foundation amount/footing	NaN	Excavation	NaN m ³