

FAZ10300 Pull Up Bars



An ideal workout station for accessible own bodyweight training. Featuring multiple handles, i.e. rotating gym rings, balls and bars with varying diameters, the Pull Up Bars allow for a great variety in difficulty levels and types of exercise. By placing the feet on the horizontal bars beginners can decrease their bodyweight during pull ups and work their way up to advanced training.

Product Line	Outdoor Fitness
Category	Cross Training
Age group	13+
Max. fall height (CM)	167
Total height (CM)	334
Safety Zone	21.5 m ²



**SUR-
FACE**

**IN-
GROU.**



ASTM

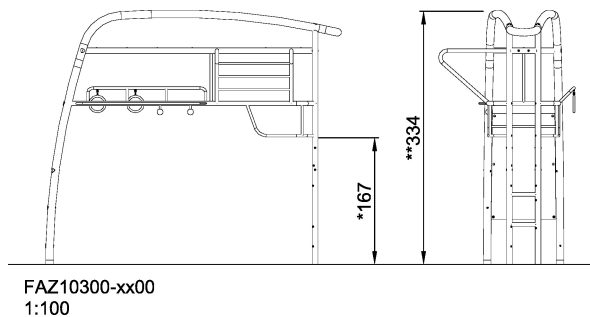
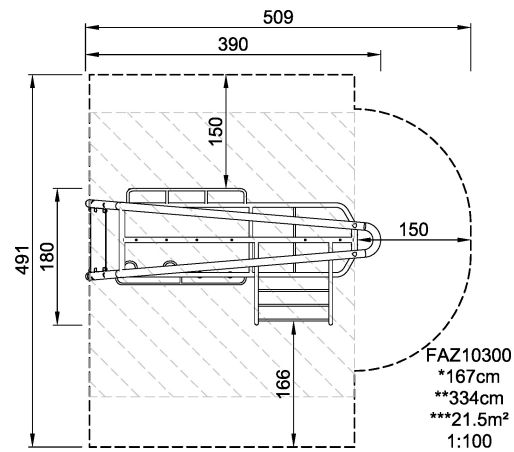

* = Highest designated play surface.
** = Total height of product.

Weight/heaviest parts	kg.	Installation (Manpower)	1 Persons
Concrete required	NaN m3	Installation (Hours)	9 Hours
Foundation amount/footing	NaN	Excavation	NaN m3