

FAZ20200

Pull Up Bars, Parallel Bars & Multi Net Link

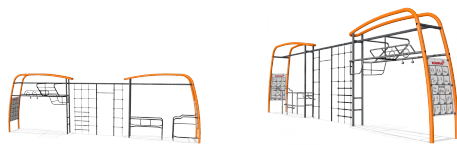

The ideal street workout combination of own bodyweight training equipment for creative and free movement while developing overall body strength and control. The three different training tools offer an endless amount of exercise opportunities for beginner and pro, resulting in a different workout every time.

Product Line	Outdoor Fitness
Category	Cross Training
Age group	13+
Max. fall height (CM)	286
Total height (CM)	334
Safety Zone	48 m2



**SUR-
FACE**

**IN-
GROU.**



ASTM

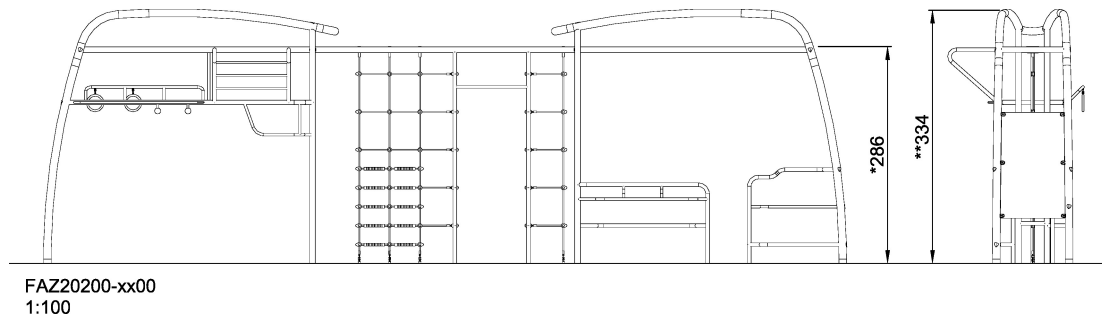
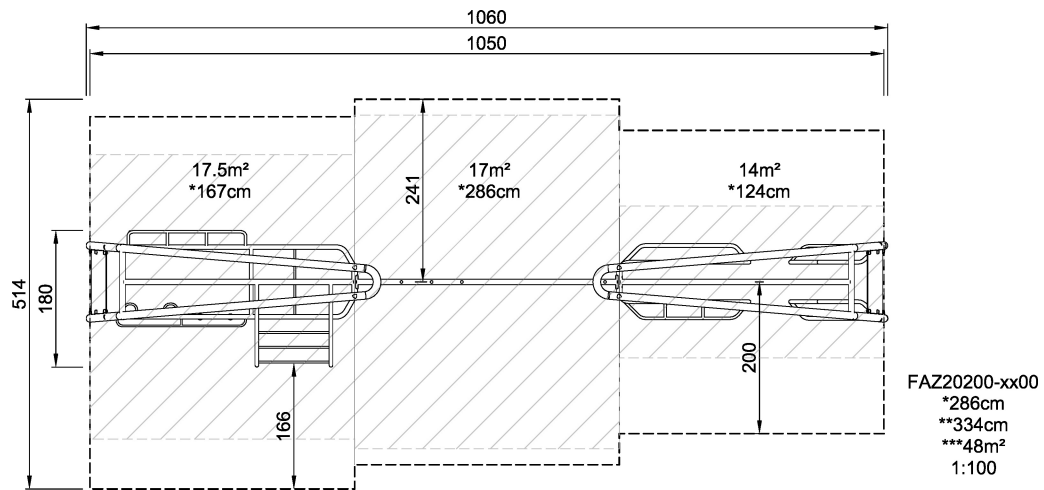

* = Highest designated play surface.
** = Total height of product.

Weight/heaviest parts	kg.	Installation (Manpower)	1 Persons
Concrete required	NaN m3	Installation (Hours)	19 Hours
Foundation amount/footing	NaN	Excavation	NaN m3