

FAZ10400 Parallel Bars



Two sets of parallel bars of three different heights, with cleverly placed side bars for an accessible and functional training for all. The Parallel Bars are suitable for beginners who want to learn how to do dips. They can start with leaning push-ups against the bar, and can later on move on to actual dips, which can initially be made easier by resting the feet on the additional bars. Dips are great for strengthening the chest, shoulder and arm muscles.

Product Line	Outdoor Fitness
Category	Cross Training
Age group	13+
Max. fall height (CM)	124
Total height (CM)	334
Safety Zone	18.3 m ²



**SUR-
FACE**

**IN-
GROU.**



ASTM

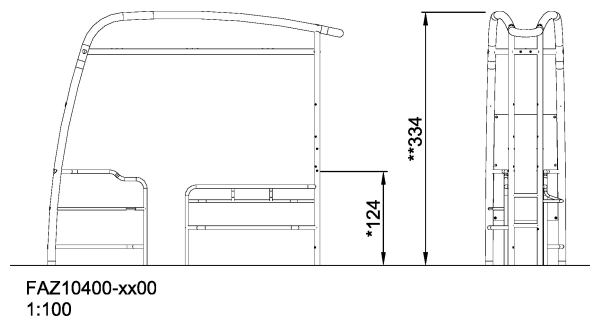
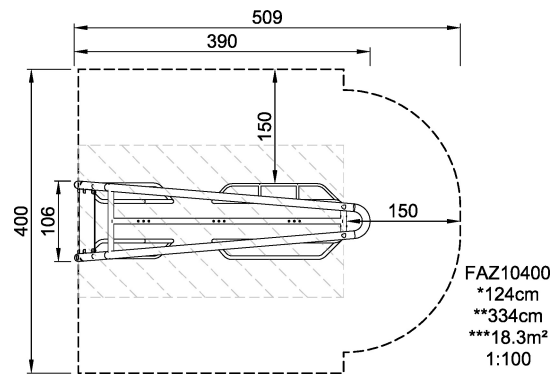

* = Highest designated play surface.
** = Total height of product.

Weight/heaviest parts	kg.	Installation (Manpower)	1 Persons
Concrete required	NaN m3	Installation (Hours)	9 Hours
Foundation amount/footing	NaN	Excavation	NaN m3