

FSW21100 Hurdles

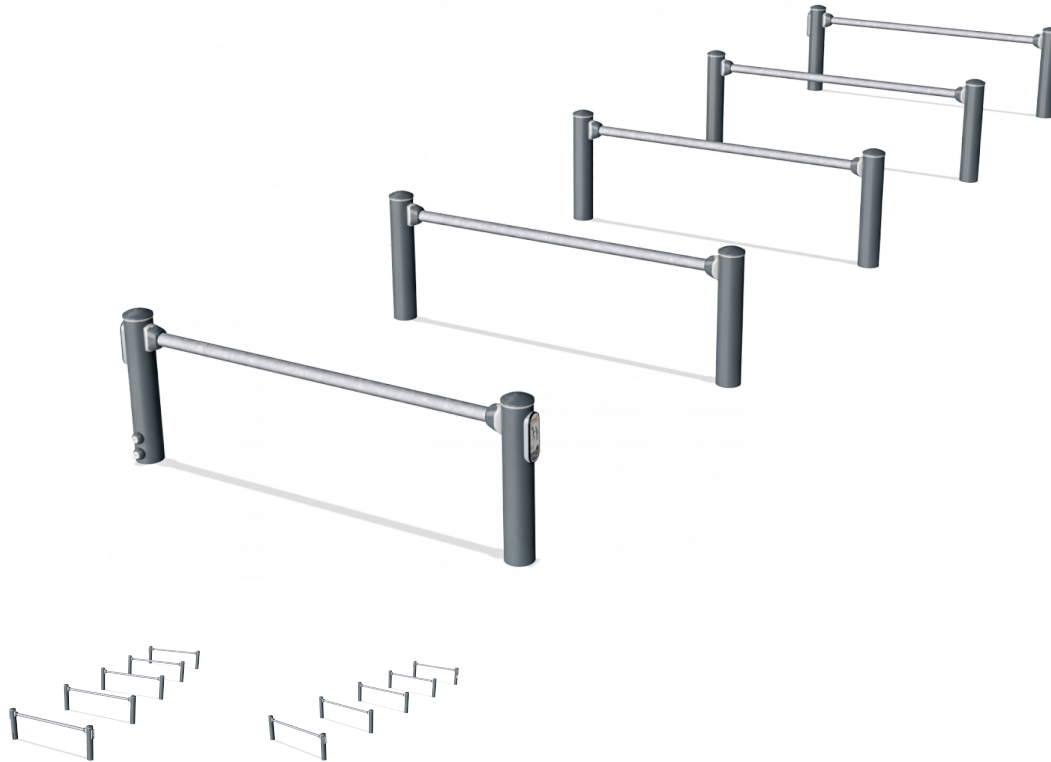

The five hurdles form an obstacle that can be overcome in several ways. If you do not mind getting dirty you can 'belly crawl' underneath them. Otherwise you go over the hurdles by walking or running. A single hurdle can also be used for exercises on the spot such as push ups.

Product Line	Sport & Fitness
Category	Obstacle Courses
Age group	13+
Max. fall height (CM)	50
Total height (CM)	57
Safety Zone	42 m2



**SUR-
FACE**

**IN-
GROU.**



ASTM

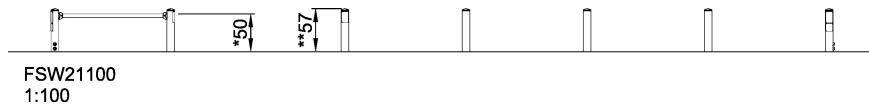
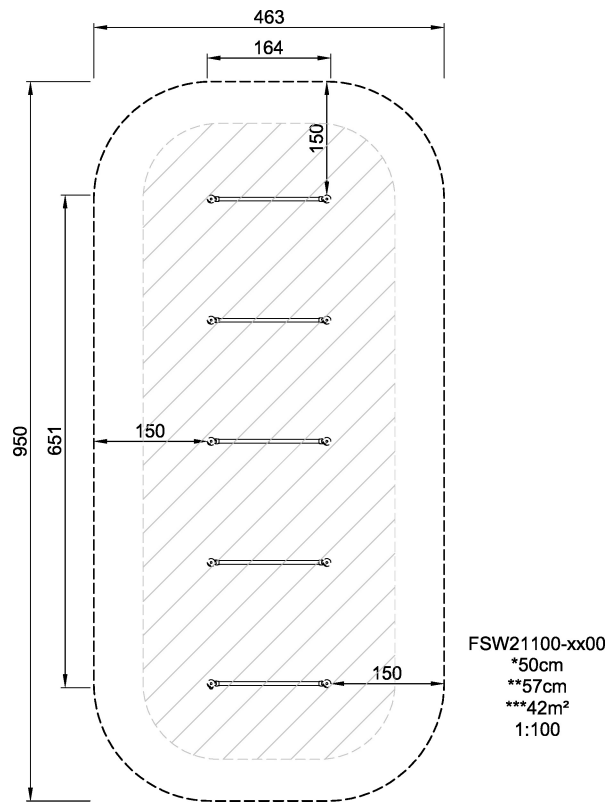

* = Highest designated play surface.
** = Total height of product.

Weight/heaviest parts	kg.	Installation (Manpower)	1 Persons
Concrete required	NaN m ³	Installation (Hours)	3 Hours
Foundation amount/footing	NaN	Excavation	NaN m ³