

FSW21700

# Hexagon Pull Up Station



The Hexagon Pull Up Station can be used in many ways by six users at the same time. From pull ups where you train the upper body to knee raises that work your abdominal muscles. There are more than 20 exercises in the KOMPAN Sport & Fitness app that you can do at this station.

<b>Product Line</b>	Outdoor Fitness
<b>Category</b>	Street Workout & Calisthenics
<b>Age group</b>	13+
<b>Max. fall height (CM)</b>	133
<b>Total height (CM)</b>	240
<b>Safety Zone</b>	26 m2



**SUR-  
FACE**

**IN-  
GROU.**



**ASTM**

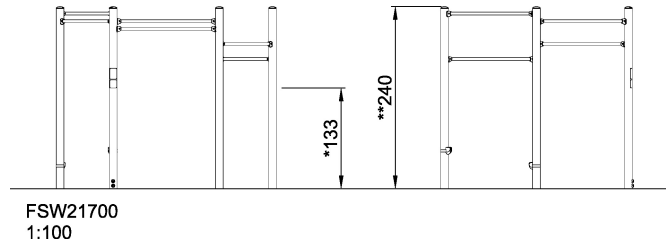
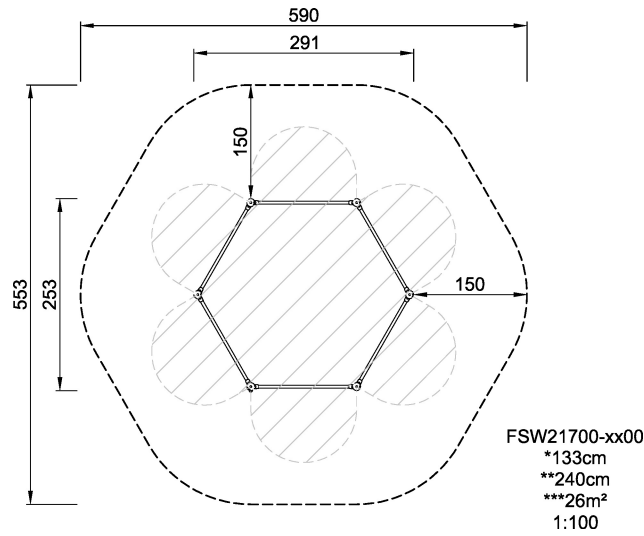

\* = Highest designated play surface.  
\*\* = Total height of product.

<b>Weight/heaviest parts</b>	kg.	<b>Installation (Manpower)</b>	1 Persons
<b>Concrete required</b>	NaN m3	<b>Installation (Hours)</b>	3 Hours
<b>Foundation amount/footing</b>	NaN	<b>Excavation</b>	NaN m3