

# FSW20200 Dip Bench

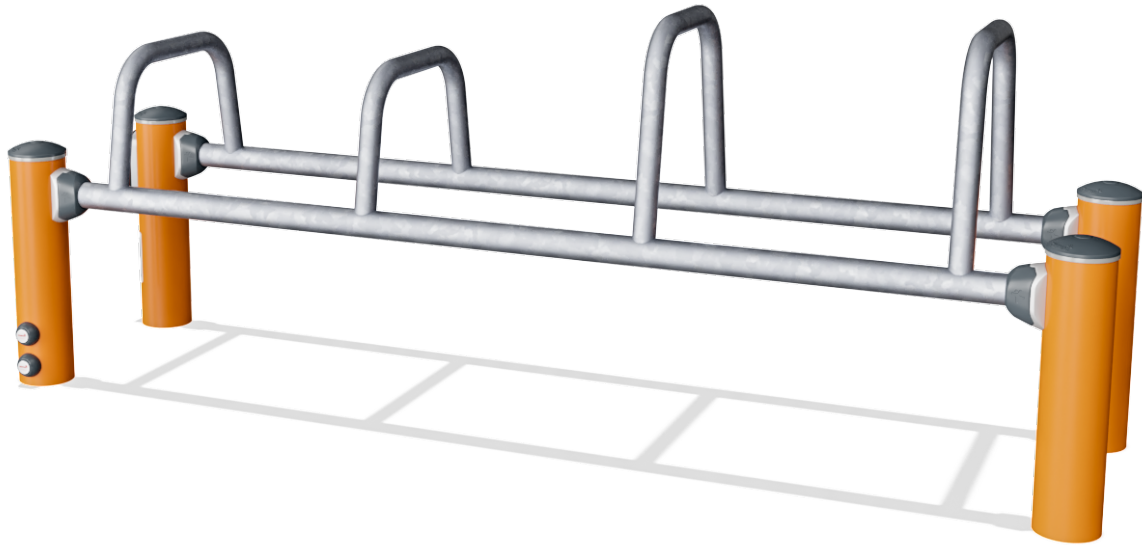

A row of parallel handle bars suitable for the more advanced hand balancing exercises such as hand stand pushups, and perfect for dips, which are ideal exercises for strengthening the chest, shoulder and arm muscles.

<b>Product Line</b>	Outdoor Fitness
<b>Category</b>	Street Workout & Calisthenics
<b>Age group</b>	13+
<b>Max. fall height (CM)</b>	73
<b>Total height (CM)</b>	73
<b>Safety Zone</b>	15.5 m <sup>2</sup>



**SUR-  
FACE**

**IN-  
GROU.**



**ASTM**

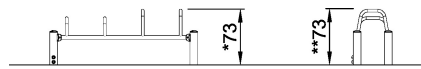
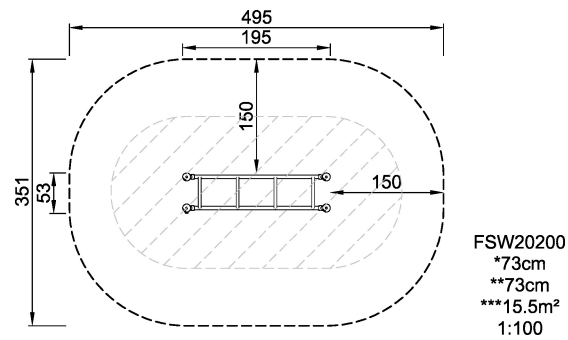

FSW20200-xx01  
1:100

\* = Highest designated play surface.  
\*\* = Total height of product.

<b>Weight/heaviest parts</b>	kg.	<b>Installation (Manpower)</b>	1 Persons
<b>Concrete required</b>	NaN m3	<b>Installation (Hours)</b>	2 Hours
<b>Foundation amount/footing</b>	NaN	<b>Excavation</b>	NaN m3