

FSW20400 Decline Bench

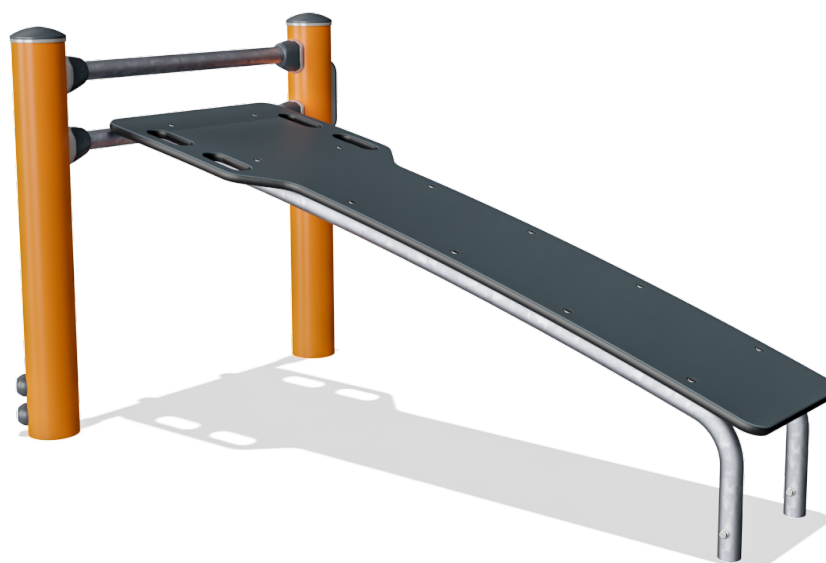

The incline bench, similar to the straight bench, is perfect for training the core with lower back and ab exercises such as leg lifts and sit ups. The durable Ekogrip® surfacing offers perfect grip, allowing the bench to be used as a jump box for performing various step and jump exercises under all weather conditions. The bench has a 15 degree incline, increasing the difficulty level of the exercises, making you work out harder.

Product Line	Outdoor Fitness
Category	Cross Training
Age group	13+
Max. fall height (CM)	63
Total height (CM)	81
Safety Zone	14 m ²



**SUR-
FACE**

**IN-
GROU.**



ASTM

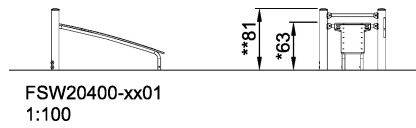
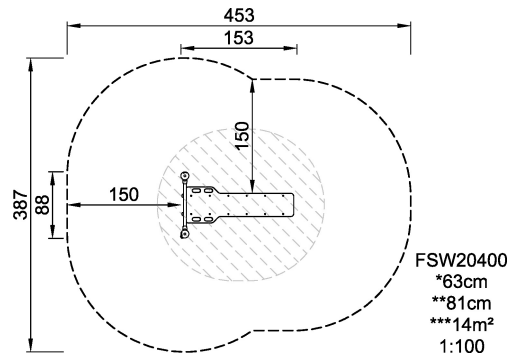

* = Highest designated play surface.
** = Total height of product.

Weight/heaviest parts	kg.	Installation (Manpower)	1 Persons
Concrete required	NaN m ³	Installation (Hours)	2 Hours
Foundation amount/footing	NaN	Excavation	NaN m ³