

# FST108 Crosstrainer

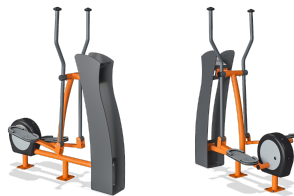

The Crosstrainer is perfect for improving stamina. The advantage of the Crosstrainer is that the movements are large but smooth and they involve both the arms and the legs, this enables the user to simultaneously train all the major muscle groups and burn a lot of energy.

<b>Product Line</b>	Outdoor Fitness
<b>Category</b>	Circuit Training
<b>Age group</b>	13+
<b>Max. fall height (CM)</b>	53
<b>Total height (CM)</b>	184
<b>Safety Zone</b>	13.5 m <sup>2</sup>



**SUR-  
FACE**

**IN-  
GROU.**



**ASTM**

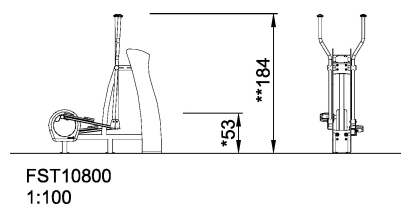
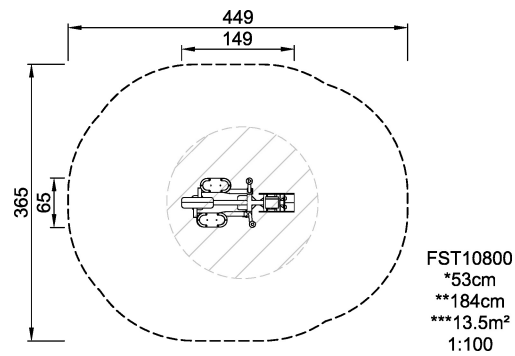

\* = Highest designated play surface.  
\*\* = Total height of product.

<b>Weight/heaviest parts</b>	kg.	<b>Installation (Manpower)</b>	1 Persons
<b>Concrete required</b>	NaN m <sup>3</sup>	<b>Installation (Hours)</b>	2 Hours
<b>Foundation amount/footing</b>	NaN	<b>Excavation</b>	NaN m <sup>3</sup>