

FAZ10500 Core Twist



Innovative and resistance adjustable core training. The two poles rotate 360° clock- and counterclockwise with a resistance that can be determined by speed of movement. Combined with an ab station targeted at increasing upper body strength, the Core Twist offers everyone a complete functional workout aimed at increasing overall strength and core stability.

Product Line	Outdoor Fitness
Category	Cross Training
Age group	13+
Total height (CM)	334
Safety Zone	15 m2



**SUR-
FACE**

**IN-
GROU.**



ASTM

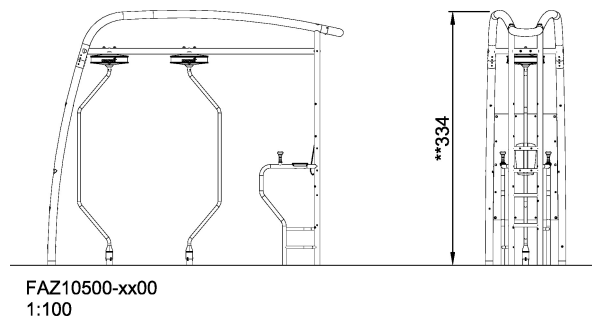
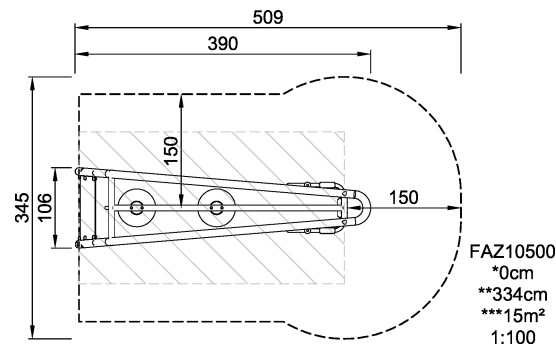

* = Highest designated play surface.
** = Total height of product.

Weight/heaviest parts	kg.	Installation (Manpower)	1 Persons
Concrete required	NaN m ³	Installation (Hours)	10 Hours
Foundation amount/footing	NaN	Excavation	NaN m ³