

# Pneumatic Gully

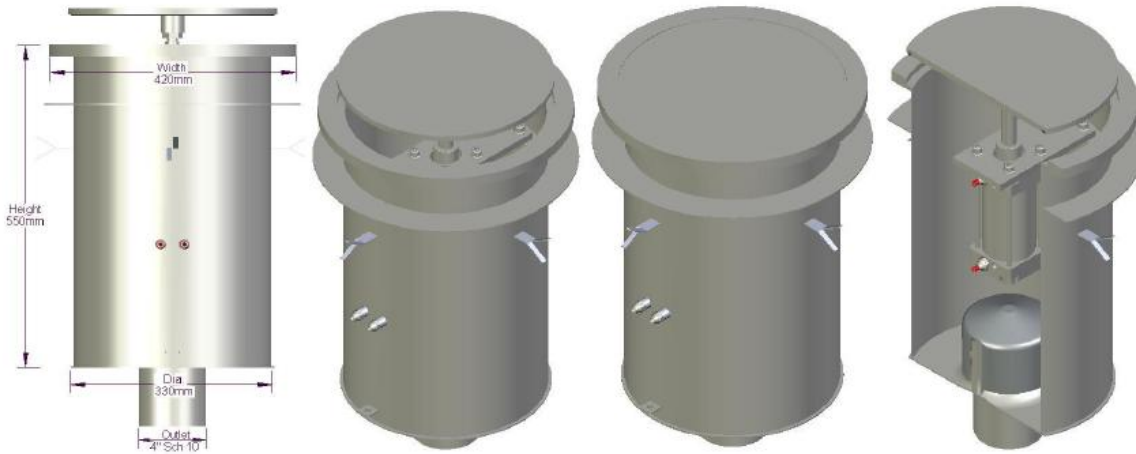

|                                     |   |                          |   |
|-------------------------------------|---|--------------------------|---|
| Tiled Floor<br>(request square top) | ✓ | Epoxy Resin Covering     | ✓ |
| Concrete Floor                      | ✓ | Vinyl (option available) | ✓ |

## Fixed Height



- Pharmaceutical
- Chemical Plants
- Food Processing
- Drinks Processing

| Ref            | Height | Width | Dia. | Outlet    | Flow Rate * |
|----------------|--------|-------|------|-----------|-------------|
| KVCRP420/4" RD | 550    | 420   | 330  | 4" Sch 10 | 11.8 l/s    |
| KVCRP420/6" RD | 550    | 420   | 330  | 6" Sch 10 | 25.9 l/s    |

## Fixed Height - Side Outlet

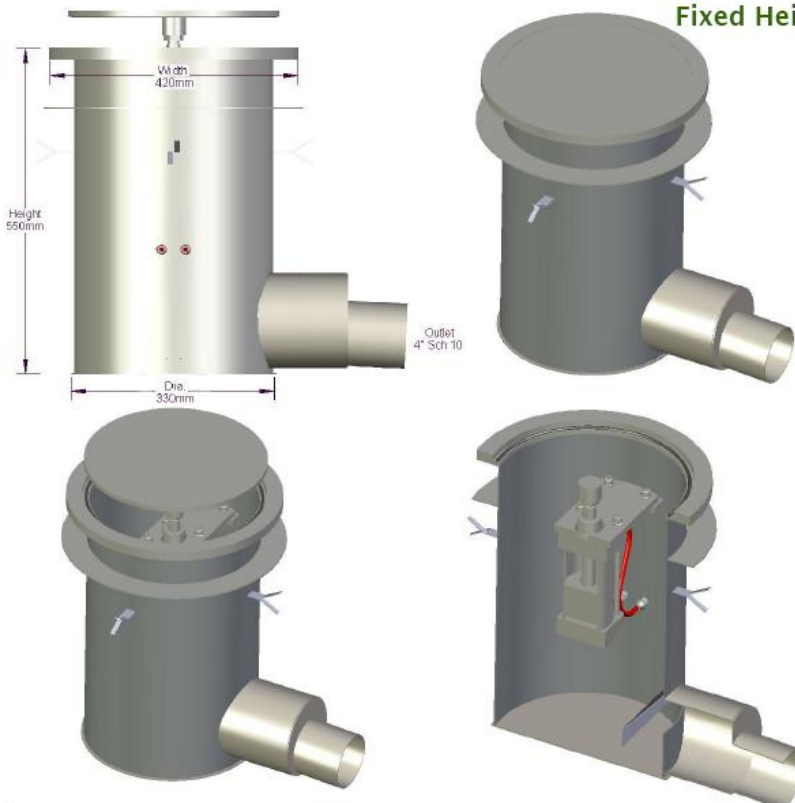

| Specification Clause Options | Please select                          |
|------------------------------|--|
| Stainless Grade              | 304/316                                |
| Holding Flange               | <input type="checkbox"/>               |
| Outlet Flange                | ANSI B 16.5 <input type="checkbox"/>   |
|                              | BS4504 <input type="checkbox"/>        |
|                              | Polypropylene <input type="checkbox"/> |
| Puddle Flange                | <input type="checkbox"/>               |
| Damp-Proof Membrane          | <input type="checkbox"/>               |
| Increased Height (Flow Rate) | <input type="checkbox"/>               |
| Other - please mark here     |  |

| Ref            | Height | Width | Dia. | Outlet    | Flow Rate |
|----------------|--------|-------|------|-----------|-----------|
| KHCRP420/4" RD | 550    | 420   | 330  | 4" Sch 10 | 13.2 l/s  |
| KHCRP420/6" RD | 550    | 420   | 330  | 6" Sch 10 | 17.6 l/s  |

**Special Loading Requirements**  
 Wheel Diameter \_\_\_\_ mm  
 Solid  Pneumatic   
 Weight of vehicle inc load \_\_\_\_\_

**Special Flow Rate Requirements** \_\_\_\_ l/s

**Specification Clause - Delete or amend underlined words as appropriate**

The gullies are to be KVCRP420/4" RD, grade 316 stainless steel, as supplied by Kent Stainless Ltd.  
 UK Freephone 0800 376 8377. T: +353(0)53 914 3216. F: +353 (0)53 914 1802 E: info@kentstainless.com.  
 The gully will be complete with foul air trap, holding flange, ANSI B.16.5 outlet flange etc. (see specification clause options). Grating shall be sealed type to load class B.