

Angle Frame & Grating

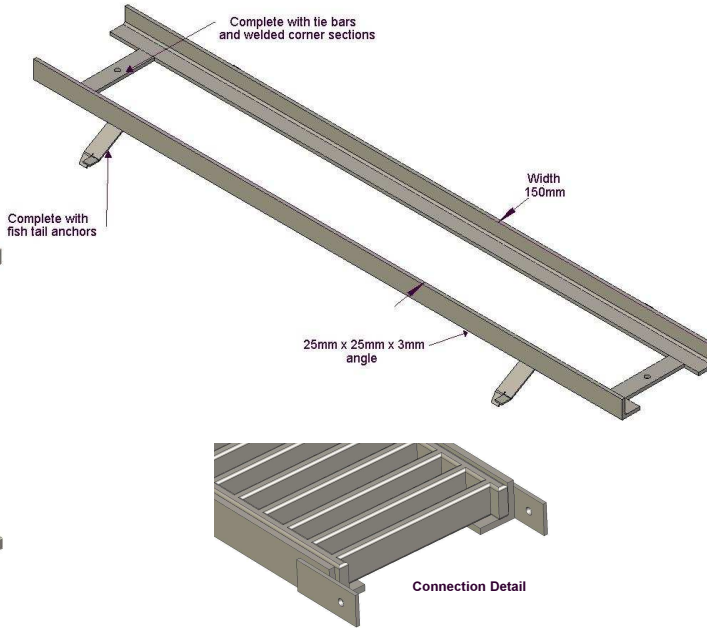

Tiled Floor	✓ Epoxy Resin Covering	✓
Concrete Floor	✓ Vinyl	✗

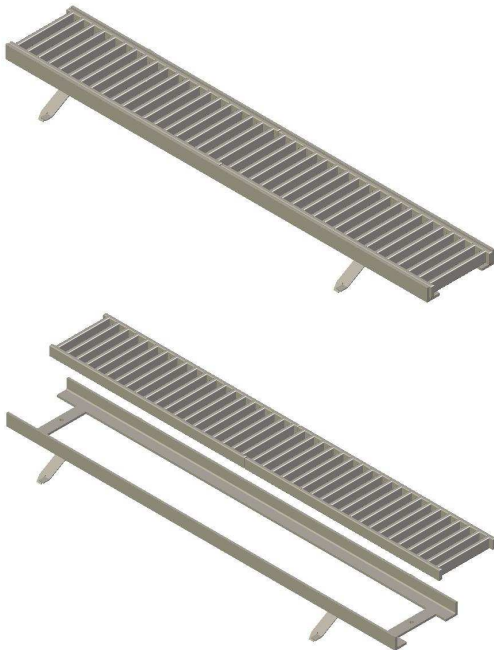

- Kitchens
- Hospitals
- Meat Processing
- Chemical Plants
- Swimming Pools
- Food Processing
- Drinks Processing
- Streetscapes
- Dairies
- Hotels
- Restaurants

Ref	Height	Width
KAF150	30	150
KAF200	30	200
KAF300	30	300

Specification Clause Options	Please select
Stainless Grade	304 / 316
Lock-Down Grating	<input type="checkbox"/>
Other - please mark here	

Grating*

	Plain Mesh Load Class A Load Class B Load Class C		Smoothline Grating Load Class B Load Class C
	Single Antislip Mesh Load Class A Load Class B Load Class C		Heelslot Load Class A Load Class B
	Ladder Load Class B Load Class C Load Class D		HeelMesh Load Class A Load Class B
	Antislip Ladder Load Class B Load Class C Load Class D		Perforated Load Class A Load Class B Load Class C Load Class D

Special Loading Requirements
 Wheel Diameter ____mm
 Solid Pneumatic
 Weight of vehicle inc load ____
Special Flow Rate Requirements ____ l/s

* Free area on perforated, heelmesh, heelslot and sealed gratings reduce flow rate.

Specification Clause - Delete or amend underlined> words as appropriate

The frame and grating are to be KAF150, grade 304 stainless steel, as supplied by Kent Stainless Ltd.
 UK Freephone **0800 376 8377**. T: **+353(0)53 914 3216**. F: **+353 (0)53 914 1802** E: **info@kentstainless.com**.
 The frame & grating will be complete with lock down grating (see specification clause options above). Grating shall be mesh type to load class A.