

Centre Scientifique et Technique du Bâtiment

4, avenue du Recteur Poincaré
F-75782 PARIS Cedex 16
Tél. : (33) 01 40 50 28 28
Fax : (33) 01 45 25 61 51

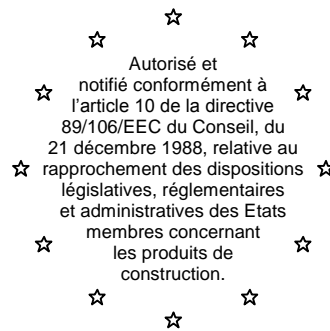

CSTB
le futur en construction

MEMBRE DE L'EOTA

European Technical Approval **ETA-08/0159**

(English language translation, the original version is in French language)

Trade name:

Nom commercial :

AIRFLEX

Holder of approval:

Titulaire :

KdB Isolation
3, avenue de l'Europe
Parc d'Activité de Val de Moine
49230 Saint Germain sur Moine

Generic type and use of construction product:

Type générique et utilisation prévue du
produit de construction :

Product with radiant heat reflective component for use in thermal
insulation systems of building envelopes

Produit réfléchissant destiné à l'isolation thermique des bâtiments

Validity from / to:

Validité du :
au :

01/06/2013
01/06/2018

Manufacturing plant:

Usine de fabrication :

KdB Isolation
3, avenue de l'Europe
Parc d'Activité de Val de Moine
49230 Saint Germain sur Moine

This European Technical Approval contains:

Le présent Agrément Technique Européen
contient :

**15 pages including 2 annexes which form an integral part of
the document**

14 pages incluant 2 annexes faisant partie intégrante du document.



European Organisation for Technical Approvals
Organisation pour l'Agrément Technique Européen

I LEGAL BASES AND GENERAL CONDITIONS

- 1 - This European Technical Approval is issued by the Centre Scientifique et Technique du Bâtiment (CSTB) in accordance with:
 - Council Directive 89/106/EEC of 21 December 1988 on the approximation of laws, regulations and administrative provisions of Member States relating to construction products¹, modified by the Council Directive 93/68/EEC of 22 July 1993²;
 - Décret no. 92-647 du 8 juillet 1992³ concernant l'aptitude à l'usage des produits de construction;
 - Common Procedural Rules for Requesting, Preparing and the Granting of European Technical Approvals set out in the Annex of Commission Decision 94/23/EC⁴;
 - Evaluation criteria adopted by approval bodies jointly acting within EOTA and established in the document « Products with radiant heat reflective component for use in thermal insulation systems of building envelopes (wall, ceiling, floor and roof) » edition n°6 February 2007.
- 2 - The Centre Scientifique et Technique du Bâtiment is authorised to check whether the provisions of this European Technical Approval are met. Checking may take place in the manufacturing plant (for example concerning the fulfilment of assumptions made in this European Technical Approval with regard to manufacturing). Nevertheless, the responsibility for the conformity of the products with the European Technical Approval and for their fitness for the intended use remains with the holder of the European Technical Approval.
- 3 - This European Technical Approval is not to be transferred to manufacturers or agents of manufacturer other than those indicated on page 1; or manufacturing plants other than those indicated on page 1 of this European Technical Approval.
- 4 - This European Technical Approval may be withdrawn by the Centre Scientifique et Technique du Bâtiment pursuant to Article 5 (1) of the Council Directive 89/106/EEC.
- 5 - Reproduction of this European Technical Approval including transmission by electronic means shall be in full. However, partial reproduction can be made with the written consent of the Centre Scientifique et Technique du Bâtiment. In this case, partial reproduction has to be designated as such. Texts and drawings of advertising brochures shall not contradict or misuse the European Technical Approval.
- 6 - The European Technical Approval is issued by the approval body in its official language. This version corresponds to the version circulated within EOTA. Translations into other languages have to be designated as such.

¹ Official Journal of the European Communities no. L 40, 11.2.1989, p. 12

² Official Journal of the European Communities no. L 220, 30.8.1993, p. 1

³ Journal Officiel de la République française du 14 juillet 1992

⁴ Official Journal of the European Communities no. L 17, 20.1.1994, p. 34

II SPECIFIC CONDITIONS OF THE EUROPEAN TECHNICAL APPROVAL

1. Definition of product and intended use

1.1. Definition of product

This European Technical Approval applies to the following reflective product:

- AIRFLEX.

The reflective product AIRFLEX is composed as following:

- 2 films made up of polyethylene and having 3,7 mm thickness : one film is in air bubbles and the other one serves as the support. Each polyethylene film is of 140 μm thickness and made with an additive of flame retardant. The bubbles have a nominal diameter of 9,5mm.
- 1 foam layer of polyethylene having a nominal thickness of 3 mm and a density of 25 kg/m^3 . The foam is made with an additive of flame retardant.
- 2 aluminium layers. Each layer is constituted as following :
 - o 1 aluminium foil having a nominal thickness of 30 μm .
 - o 1 layers of a protective nitrocellulose lacquer (coating $<1\mu\text{m}$) which prevents the corrosion of the aluminium layer. The lacquer doesn't contain an additive of flame retardant
 - o 1 layer of polyethylene (17 μm) allowing to reinforce the adhesion of the aluminium foil on the bubble layer. Aluminium foil is fixed to bubble layer under hot conditions (without additive glue).

The composition of product is presented in the following table:

Tableau 1: Composition

AIRFLEX	Masse per square metre (g/m^2)	Tolerance
Bubble layer (x 2)	150	$\pm 10 \text{ g/m}^2$
Polyethylene layer (x 2)	15	$\pm 2 \text{ g/m}^2$
Polyethylene foam (x 1)	63	$\pm 8 \text{ g/m}^2$
Aluminium layer 30 μm (x 2)	81	$\pm 6 \text{ g/m}^2$
Nitrocellulose lacquer (x 2)	1	$\pm 0,2 \text{ g/m}^2$

Nota: All layers are assembled by thermo-weld in the center of the breadth (or strip) and in both extremities.

On the other hand, in the extremities of the product, a film of glue " Hot Melt " of nominal width of 20 mm, is continuously deposited on the aluminium layer (on polyethylene film) to allow a stack of breadths (figure 2). This film of glue is protected by a glue paper.

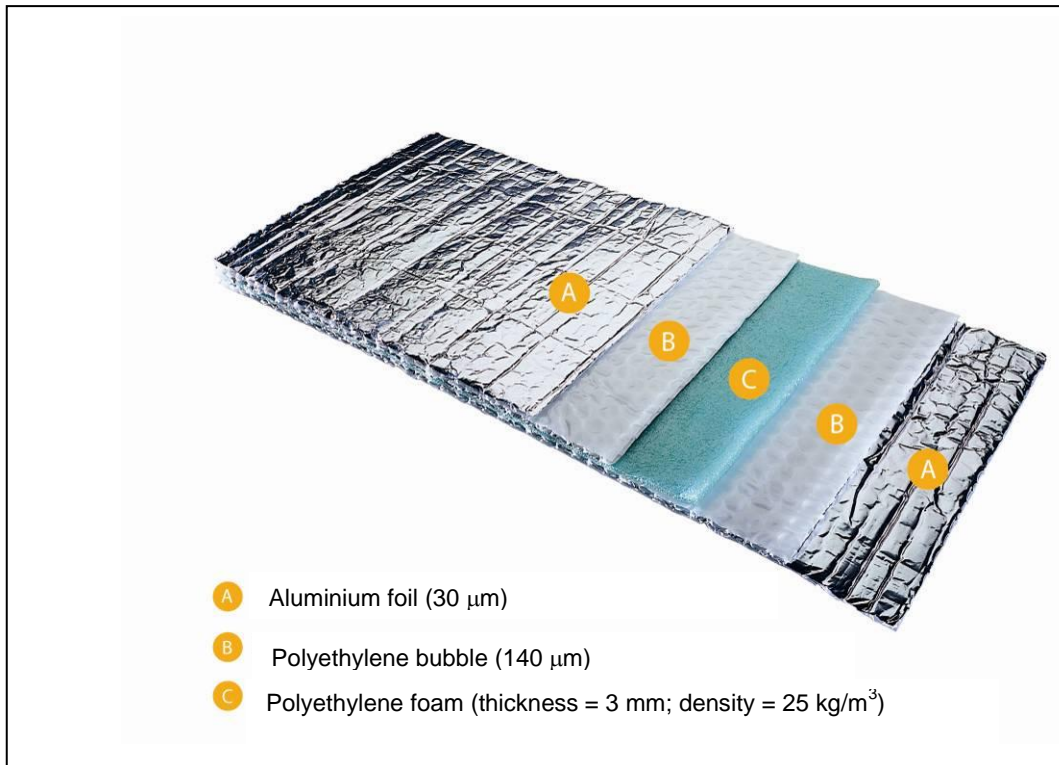

1.2. Intended use

Reflective product KDB is intended to be used in constructive system as an additional thermal insulation. It contributes to an increase in the thermal resistance of a thermal system in the following areas of application:

Application for walls

- Vertical walls in timber frame constructions,
- Vertical masonry walls with fixation of product on timber frame constructions or similar structures,

Application for roofs

- Pitched roof, under rafters with additional insulation over,
- Ceilings under attics under joists or timbers.

Application for ceilings / floors

- Low-floor constructions
- Intermediate ceilings.

The product is always applied on the warm side of a construction in order to avoid any condensation risk, with an additional thermal insulation product.

The thermal insulation product shall only be installed in structures where it is protected from rain, weathering and moisture.

The product is installed stretched, for example fastened on rafters, cleats or battens, by leaving possibly on both sides of the product one or two air spaces. In the absence of both possible air spaces having thermal resistance determined according to §4.2.1, the thermal resistance of the product once installed is equal to the intrinsic thermal resistance given in § .2.5.

This European Technical Approval does not cover the complete or finished system of insulation. As for the application of all products insulating, the national codes of practice and regulations must be respected for design and implementation of construction systems.

The provisions made in this European Technical Approval are based on an assumed working life of the product of 25 years, provided that the conditions laid down in sections 4.2, 5.1 and 5.2 for packaging, transport, storage, installation and use are met. The indications given on the working life cannot be interpreted as a guarantee given by the producer, but are to be regarded only as a means for choosing the right products in relation to the expected economically reasonable working life of the works.

2. Characteristics of product and methods of verification

2.1. Composition and manufacturing-process

Details of composition and manufacturing process having been subjected to the technical approval tests are deposited at the CSTB.

2.2. Dimensions

2.2.1. Length and width

Length and width are determined according to EN 822⁵.

The nominal length and width are:

length: : 25 ou 12,5 m -0 % +2 %.

width: 1,20 m \pm 1 %.

2.2.2. Thickness

The thickness of the product is determined according to European standard EN 823⁶.

The nominal thickness is given according to its tolerance as follows:

Thickness: 10,1 mm \pm 10 %

2.3. Mass per square metre

Mass per square metre is determined according to the standard EN 1606⁷.

The nominal value of mass per square metre is given according to its tolerance as follows:

Mass per square metre: 557 g/m² \pm 10 %

2.4. Water vapour diffusion resistance

The water vapour diffusion resistance μ is determined according the EN 12086⁸, conditions B.

The nominal value μ is higher or equal than 3 10⁴.

The thickness of equivalent layer of air having an equivalent vapour diffusion resistance is : S_d = 304 m

2.5. Core thermal resistance

The core thermal resistance is determined according to the EN 12667⁹.

The test specimens are measured to determine the fractile value of thermal resistance according to EN ISO 10456¹⁰.

⁵ EN 822: 1994: Thermal insulation products for building applications - Determination of length and width
⁶ EN 823: 1994: Thermal insulation products for building applications - Determination of thickness
⁷ EN 1602:1997 Thermal insulating products for building applications - Determination of the apparent density
⁸ EN 12086 : 1997 Thermal insulating products for building applications - Determination of water vapour transmission properties
⁹ EN 12667:2001 Thermal performance of building materials and products - Determination of thermal resistance by means of guarded hot plate and heat flow meter methods - Products of high and medium thermal resistance
¹⁰ EN ISO 10456 1999 Building materials and products - Procedures for determining declared and design thermal values (ISO 10456:1999)

The fractile value of thermal resistance is $R_{(10^{\circ}\text{C},90/90)} = 0,29 \text{ m}^2.\text{K/W}$ representing at least 90 % of the production with a confidence level of 90%.

The declared value of thermal resistance is $R_D = 0,29 \text{ m}^2.\text{K/W}$.

2.6. Emissivity

The emissivity of two surfaces of the product is measured according to the appendix D and then given according to accelerated ageing described in annex B and determined according to annex C of evaluation criteria of February 2007.

The fractile value of emissivity according to EN ISO 10456 is $\varepsilon_s = \varepsilon_{90/90} = 0,05$, representing at least 90 % of the production with a confidence level of 90%.

The declared value of emissivity for both faces is $\varepsilon_D = 0,06^{11}$.

2.7. Corrosion developing capacity

The test is carried out according to ISO 9227:1991, T3¹²: “Corrosion tests in artificial atmospheres – Salt spray tests”. In order to check the behaviour of coatings of product with respect to corrosion when it is subjected to an air charged with chloride (for example salt fog).

The test results concerning the measure of loss of mass and the visual check of the state of surface of the product show that there is no sensitive loss of material.

2.8. Peel strength

The test is carried out according to EN ISO 11339¹³:

- before ageing, average of peel strength resistance : $F_p = 0,5 \text{ kN/m}$,
- after ageing, average of peel strength resistance: $F_p = 0,5 \text{ kN/m}$.

The tolerance on the values measured is $\pm 20 \%$.

2.9. Tensile strength

The measurement of tensile strength parallel to product surface is carried out according to EN 1608¹⁴.

The value of the tensile strength is the maximal of the strength σ_t applied in two cases:

- With the product alone :
 - o before ageing \square : $\sigma_t = 500 \text{ kPa}$,
 - o after ageing : $\sigma_t = 479 \text{ kPa}$,
- With the product assembled using the adhesive tape:
 - o before ageing : $\sigma_t = 174 \text{ kPa}$,
 - o after ageing : $\sigma_t = 212 \text{ kPa}$.

The tolerance on the values measured is $\pm 20 \%$.

2.10. Resistance to tearing

¹¹ This value corresponds to a surface of the product if the neighbouring possible air space is not ventilated or weakly ventilated as defined in EN ISO 6946.

EN ISO 6946 Building components and building elements - thermal resistance and thermal transmittance - calculation method.

¹² ISO 9227:1991, T3 Corrosion tests in artificial atmospheres – Salt spray tests

¹³ EN ISO 11339:2003 T-peel test for the determination of the peel strength of an adhesive by measuring the peeling force of a T- shaped bonded assembly of two flexible adherents.

¹⁴ EN 1608:1996 Thermal insulating products for building applications - Determination of tensile strength parallel to faces

The measurement of resistance to tearing is carried out according to the EN 12310-1¹⁵ before and after ageing.

- before ageing : $\sigma_t = 144 \text{ N}$,
- after ageing : $\sigma_t = 140 \text{ N}$,

The tolerance on the values measured is $\pm 20 \%$.

2.11. Reaction to fire

The measurement of resistance to tearing is carried out according the annex E by using the tests allowing a classification according to the EN standard 13501-1¹⁶.

The classification of the product is: Euroclass B-s3,d0

2.12. Content and/or release of dangerous substances

The reflective product is composed mainly of layers of polyethylene bubbles of air and aluminium films.

The aluminium films are protected by a lacquer of nitrocellulose. Lacquer of nitrocellulose does not contain additive flame retardant substances.

The film of polyethylene is provided with an additive flame retardant substance. This substance is in conformity with the regulations of the Guidance Document H relating to the dangerous substances¹⁷ according to deposited declaration of manufacturer.

In addition to the specific clauses relating to dangerous substances contained in this European Technical Approval, there may be other requirements applicable to the products falling within its scope (e.g. transposed European legislation and national laws, regulations and administrative provisions). In order to meet the provisions of the EU Construction Products Directive, these requirements need also to be complied with, when and where they apply.

3. Evaluation of Conformity and CE marking

3.1. Attestation of conformity system

According to decision n° 1999/91/CE of 1999 January 25, the system of attestation of conformity is system 3 according to Council Directive 89/106/EEC Annex III laid down by the European Commission provides:

a) Tasks of the manufacturers:

- factory production control.

b) Tasks of the Notified Body:

- initial type-testing of the product.

3.2. Responsibilities

3.2.1. Tasks of the manufacturer, factory production control

The manufacturer has a factory production control system in its plant and exercises permanent internal control of production. All the elements, requirements and provisions adopted by the manufacturer are documented in a

¹⁵ EN 12310-1: 2000 Flexible sheets for waterproofing. Determination of resistance to tearing (nail shank). Bitumen sheets for roof waterproofing

¹⁶ EN 13501-1:2002-06 Fire classification of construction products and building elements - Part 1: Classification using data from reaction to fire tests

¹⁷ Guidance paper H A harmonised approach relating to Dangerous substances under the construction products directive, 18 February 2000

systematic manner in the form of written policies and procedures. This production control system ensures that the product is in conformity with the European Technical Approval.

In the framework of factory production control the manufacturer shall carry out tests and controls in accordance with the control plan¹⁸ which is fixed by this European Technical Approval.

Details of the extent, nature and frequency of testing and controls to be performed within the factory production control shall correspond to this control plan which is part of the technical documentation of this European Technical Approval.

The results of factory production control are recorded and evaluated. The records include at least the following informations:

- designation of the products and of the basic materials,
- type of control or testing,
- date of manufacture of the products and date of testing of the products or basic materials or components,
- result of control and testing and, if appropriate, comparison with requirements,
- signature of person responsible for factory production control.

On request the records shall be presented to the CSTB.

3.2.2. Tasks of the Notified Bodies

3.2.2.1. Initial type-testing

For initial type testing the results of the tests performed as part of the assessment for the European Technical Approval shall be used unless there are changes in the production line or plant. In such cases the necessary initial type testing has to be agreed between the CSTB and the approved bodies involved.

3.3. CE marking

The CE marking shall be affixed on the product. The symbol « CE » shall be accompanied by the following information.

The symbol "CE" shall be accompanied by the following information:

- name or identifying mark of the producer and manufacturing plant,
- identification of products (commercial name),
- name or identifying mark of producer and manufacturing plant,
- the last two digits of the year in which the CE marking was affixed,
- number of the European technical approval,
- nominal dimensions: thicknesses, length and width
- mass per square metre,
- declared core thermal resistance R_D ,
- declared emissivity ϵ_D
- reaction to fire (euroclasse¹⁹),

¹⁸ Control plan The control plan has been deposited at CSTB

¹⁹ European classification of reaction to fire of building materials according to the Commission Decision 2000/147/EG of 8 February 2000 implementing Article 20 of Directive 89/106/EEC on construction products.

		Name or identifying mark of the producer and manufacturing plant Address deposited of manufacturing plant number of the European Technical Approval The last two digits of the year in which the CE marking was affixed identification of products (commercial name) Code or designation of product		
Euroclass	R_D m ² K/W	emissivity ε _D	Mass per square metre g/m ²	Thickness in mm
m²/parcel	Number of parcels			length in m
The reflective product shall be protected from humidity during transport, storage and installation.				

Example of labelling

4. Assumptions under which the fitness of the product for the intended use was favourably assessed

4.1. Manufacturing

The product shall correspond as far as their composition and manufacturing process is concerned to the products subject to the approval tests. Composition and manufacturing process are deposited at the CSTB.

4.2. Installation : parameters for the design of construction works or parts of construction works

4.2.1. Determination of thermal resistance and coefficient U of thermal transmission of construction works

The value of thermal resistance or of thermal coefficient of transmission U of a wall is to be determined in accordance with the relevant national provisions as a function of installation. For example, the global thermal resistance of a wall can vary according to thickness and on-centre spacing of fixation elements of product and of air tightness performances of wall

The product once installed, allows increasing the thermal resistance of a wall by its own core thermal resistance and possible air tight space neighbouring the both sides of the product.

The thermal resistance of each additional thermal air space depends:

- design emissivity of each low emissivity layer given in the ETA,
- design thickness of each air space,
- ventilation amount of each air space (tight, weakly or highly ventilated),
- orientation of wall: for heat flow up, down or horizontal, see Annex B of EN ISO 6946:
 - o For heat flow orientation between 0° and 30° compared with horizontal plan, the calculation shall be done according to horizontal orientation of heat flow.
 - o When the heat flow orientation is strictly above 30° and lower or equal to 90°, the calculation shall be done according to the vertical orientation of heat flow.
- The thermal transmission coefficient shall be calculated to EN ISO 6946 or EN ISO 10211-2 as appropriate, taking into account of thermal bridges and fixings as defined in the relevant standard.

An example of calculation is given in Annex 2.

4.2.2. Example

An example of roof assembly of the product is described in Annex 1 as an informative indication.

4.2.3. Water vapour diffusion resistance

Constructions integrating the reflective product must be designed and carried out in order to eliminate any condensation risk inside and on the surface from the structural component.

The installation of the product must comply with the national rules of implementation by taking into account of the characterisation of the product due to its water vapour diffusion resistance value.

4.2.4. Parameters for the installation in the construction works or parts of construction works

In all the cases, the user must fulfil the national regulations, in particular in term of fire, wind resistance, risk of condensation and durability of the constructions.

The fitness for use of the product is subjected to the following conditions of implementation:

- Installation carried out by appropriate installer under the supervision of the project representative
- Installation in accordance with the manufacturer's specifications.

4.2.5. Use of the insulation products as airborne sound insulation

In case of use of the products as airborne sound insulation it is necessary to determine the airborne sound insulation for the specific construction work in question in accordance with the relevant technical rules in force.

4.2.6. Use as roof underlay

As stipulated in paragraph 1.2, the product is always posed of warm side of a construction in order to avoid any condensation risk, with an additional thermal insulation product.

The use as roof underlay (or as under-roof screens) is not aimed by this ETA.

Note: It should be noted that this use requires either ventilation in under face of the reflective product, or a high water vapour permeance of the product. In addition, the product must fulfil the requirements specified in the standard "roof underlays" or "underlays for roofing" EN 13859-1²⁰ and the specifications of implementation for each construction must comply with the code of practice and national regulations.

²⁰ EN 13859-1 Flexible sheets for waterproofing – Definitions and characteristics of underlays – Part 1 : Underlays for discontinuous roofing.

5. Recommendations

5.1. Packaging, transport and storage

The product has to be protected from moisture and dust during installation. The processing guidelines of the manufacturer have to be followed.

5.2. Accompanying information

In the information accompanying CE marking the manufacturer shall indicate that the products shall be protected from humidity during transport, storage and installation.

5.3. Maintenance and repair of the works

The product must be used only in the places where it will not be exposed to damping or disintegration.

**The original version is signed by
C. BALOCHE**

Technical Director

Example of insulation for a roof

An example of assembly of the product is described as an informative indication in the figure n° 1 for a wooden roof insulation. The product is applied interior side as an additional thermal insulation.

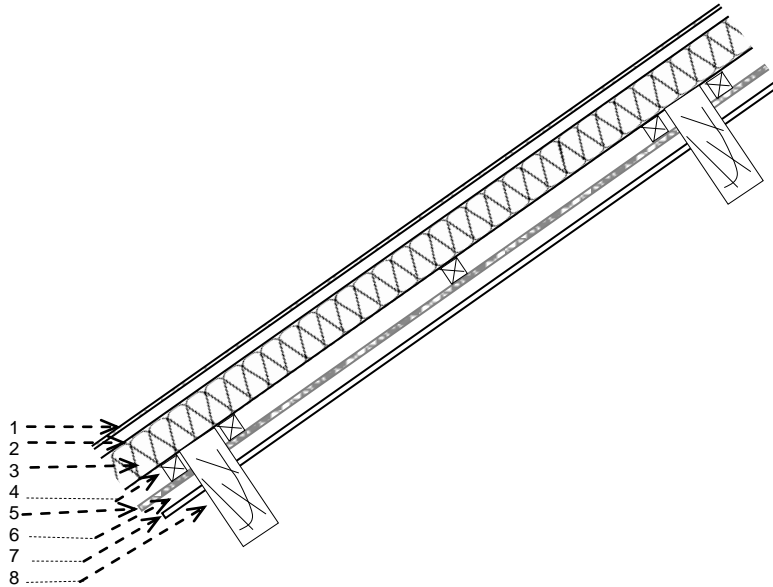

Figure 1 Example of insulation of a roof

- 1 : roof covering,
- 2 : rafters,
- 3 : insulating product installed between rafters
- 4 : cleats: first air space,
- 5 : reflective product,
- 6 : cleats: second air space,
- 7 : interior facing,
- 8 : intermediate purlins.

AIRFLEX

Products with radiant heat reflective component for use in thermal insulation systems of building envelopes

Annex 1

of European
Technical Approval
ETA-08/0159

Example of insulation for a roof

Example of calculation of thermal coefficient U for a roof

The thermal coefficient of transmission U or the thermal resistance of a wall of a roof can be given by knowing the thermal resistance of the product installed between rafters and by determining the thermal resistance of the reflective product with the two neighbouring air spaces according by as follows:

- Calculation of thermal resistance of air space according to EN ISO 6946,,
- Calculation of thermal bridges according to EN ISO 10211 du to for example to rafters, cleats, purlins.

Thermal resistance in m ² K/W		Coefficient U _{roof} in W/m ² K
Reflective product + 2 air spaces Without thermal bridges)	Reflective product + 2 air spaces + insulating product	Roof taking into account thermal bridges and thermal insulation product
1,20	4,70	0,25

Table: values of thermal resistance and thermal transmission coefficient U given for an informative indication for an example of roof insulation.

In this table the values given to informative indication cannot in any case to be representative of all the configurations of installation of the product.

Assumptions considered for the table above:

- R_{insulating product} = 3,50 m²K/W (e = 120 mm),
- R_{reflective product} = 0,29 m²K/W
- Rafters : width = 80 mm ; height = 120 mm ; on-centre spacing = 600 mm ;
- Purlins : width = 120 mm ; height = 240 mm
- cleats : width = 30 mm ; height = 40 mm ; spacing between axis = 600 mm ;
- Thickness of air space : 20 mm
- Orientation of heat flow: : up from inside to outside, heat flow orientation is strictly above 30° and lower or equal to 90°, the calculation is made according to the vertical orientation of heat flow.
- Temperatures of calculation: T_{int} = 20 °C, T_{ext} = 0°C

For the both methods A and B, the air spaces neighbouring the both sides of the product are considered as unventilated.

AIRFLEX

Products with radiant heat reflective component for use in thermal insulation systems of building envelopes

Annex 2

of European
Technical Approval
ETA-08/0159

Note : Air tightness of air spaces requires a particular care in particular:

- when the air space is slightly ventilated, the thermal resistance of the air space is the middle and when this air space is ventilated the thermal resistance of the air space is negligible.
- the joints between product parts are made tight by a specific adhesive band (see §4.2.4)
- sealing of the joints to the periphery of air spaces,

This calculation has to be performed according to national provisions by the designer using the national design values, taking into account the environment of the product in use, not the declared values from the ETA.

- Minimal thickness for thermal resistance determination :

For this example, the thickness of each air space is taken equal to 20 mm for a thickness of cleats higher or equal to 25 mm and under some care of implementation in particular :

- The nominal thickness of each air space neighbouring the product, value used to determine the thermal resistance of the insulation wall is given by control of its value during installation of the product,
- the product is installed well stretched during implementation, checking thickness of the air spaces progressively with the installation, that in any point of surface insulated, the thickness of reservation is higher or equal to the nominal thickness (for example 20 mm).

<p>AIRFLEX <i>Products with radiant heat reflective component for use in thermal insulation systems of building envelopes</i></p>	<p>Annex 2 of European Technical Approval ETA-08/0159</p>
<p>Example of calculation of thermal coefficient U for a roof</p>	