

Kalzip® FC façade system

Installation guidelines
Date 10/2011

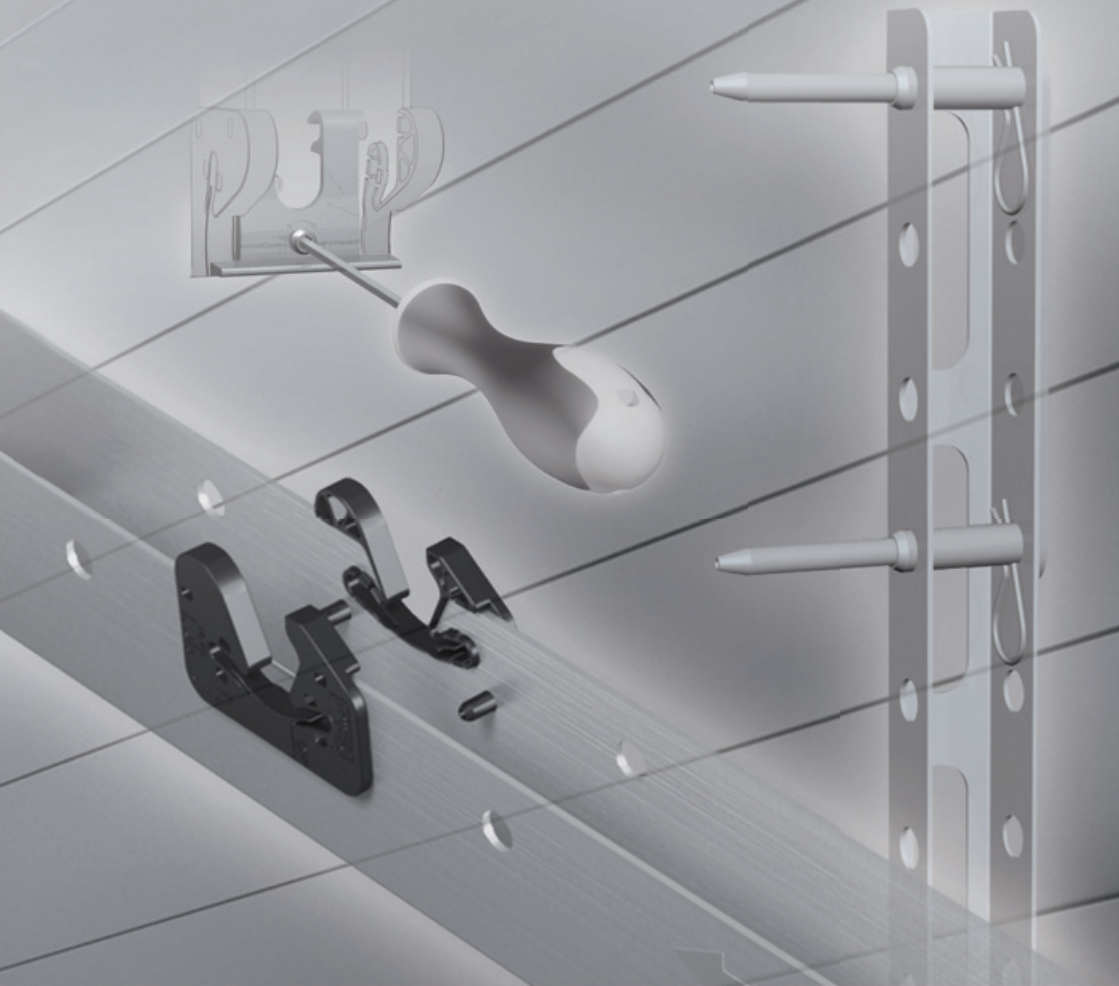



Overview	Page
1.0 Introduction	
1.0 Introduction	4
2.0 System overview	
2.0 System overview	6
3.0 Transport, storage and handling	
3.0 Transport, storage and handling	12
4.0 General information	14
4.1 Sub-construction requirements	15
4.2 Panel support requirements	20
5.0 Sub-construction installation	24
5.1 Mono-click brackets on vertical rails	26
5.2 Modular click rail NE on vertical rails	28
5.3 Modular click rail SEL on L-brackets	30
5.4 Modular click rail SE on U-brackets	32
5.5 Modular click rail SE on horizontal rails	34
5.6 Modular click rail SE on structural cassette	36
5.7 Modular click rail setting out tool	38
6.0 Horizontal panel installation	43
6.1 Panel installation (bottom to top)	44
6.2 Panel installation (top to bottom)	48
6.3 Vertical panel joints	50
6.4 Fixed points	52
6.5 Adjustment of panel position	54
6.6 Corner panels	57
7.0 Flashing installation	
7.0 Flashing installation	61
8.0 Individual panel replacement	
8.0 Individual panel replacement	63

1.0 Introduction

This installation manual specifies the correct methods for installing the Kalzip FC façade system, including support elements, panels and accessories. It should be read together with the technical approval document Zulassung Z-14.1-581 (June 2010). It should also be used in conjunction with all other applicable technical approvals, standards and safe working procedures on the construction site.

Installation of the Kalzip FC façade is carried out using proprietary system support rails fixed to an adjustable sub-construction suitable for rainscreens. The chosen sub-construction must be capable of accommodating building tolerances to achieve a plane surface in accordance with the specifications given in this manual.

The manual contains general information about the FC façade system and its components together with detailed drawings and explanatory text for installation. The drawings are not to scale and therefore should not be dimensioned. Where appropriate, drawings are labelled with metric dimensions.

Care has been taken to ensure that the information contained within this manual is correct. At the time of going to press, the diagrams and descriptions represent our current knowledge of best practice. They are intended as rules for standard applications and do not necessarily apply in all situations. Other relevant valid standards and local legislative requirements must also be taken into account.

Suggestions for or descriptions of the end use or application of products or methods of working are for information only and Kalzip accepts no liability in respect thereof. Before using information or products supplied or manufactured by Kalzip the user should satisfy himself that they are suitable for their intended purpose.

Due to the dynamic nature of product development and continuous technical improvement, Kalzip reserves the right to make amendments to the installation instructions and technical specifications given at any time without prior notice. Users should therefore check that they have the latest available edition of this manual.

September 2011

2.0 System overview

The FC façade from Kalzip is a fast-to-install, open-jointed, lightweight, flat metal rainscreen system. It provides a cost-effective solution for horizontally spanning cladding applications in both new-build and refurbishment projects.

Fixing-free supports

The FC façade system is supplied with proprietary fixing-free panel supports. Panels can be clicked into either individual support brackets (mono-click brackets) or continuous modular rails (modular click rails). In summary the system consists of:

- FC panels with edge returns
- A range of modular click rails or alternatively mono-click brackets
- Additional system components, accessories and installation tools such as the fixed point clamp, guidance snapper, flashing holder and modular click rail setting out tool

To ensure trouble-free panel installation, it is essential that the modular click rails or mono-click brackets are accurately aligned according to the guidelines in this manual to give a plane and level underlying support for the FC panels. A range of typical adjustable sub-construction options are illustrated which provide solutions for all types of backing wall.

Profile parameters

The FC panels are available from 250 mm to 500 mm in 50 mm cover width increments. Bespoke cover widths can be produced on request. The nominal profile depth is 30 mm. Panels can be roll-formed from min. 350 mm to max. 10 m standard lengths in the gauges given in Table 1.



Tabelle 1: FC panel thickness and cover width availability

Thickness (mm)	FC 30/250	FC 30/300	FC 30/350	FC 30/400	FC 30/450	FC 30/500
1.0	●	●	●	●	–	–
1.2	○	○	○	○	○	○

● Available as standard ○ Available on request – Not available

Panel edge returns

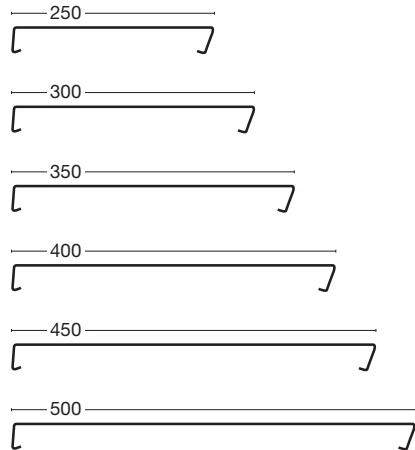
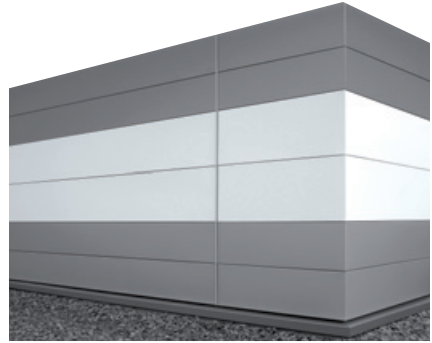
Kalzip FC façade panels are supplied as standard with edge returns. Panels can be supplied without edge returns on request. The diagrams illustrating panel installation in this manual are shown without edge returns for clarity.



Mono-click bracket

The mono-click bracket consists of a 2 mm thick aluminium bracket fitted with specially designed plastic inserts to accommodate the upper and lower FC panel edge geometry. The plastic inserts allow the panels to easily click into place and reduce any noise caused by rattling. The bracket is supplied with two pre-drilled Ø 5.2 mm holes at 50 mm centres. The bracket must always be fixed in both holes.



Modular click rails

There are three different types of modular click rail available for mounting FC panels (NE, SE and SEL). Fabricated from 2 mm thick aluminium and pre-fitted with plastic inserts, they are supplied in standard lengths between 2.7 m and 3.0 m. Bespoke lengths up to 6.0 m can be supplied on request. The rails are pre-punched with arrows indicating the correct way up.

Modular click rail NE

The modular click rail NE is a Non-structurally Effective support rail. That means it must be fixed at every panel locking position to a structurally effective support rail. The rail is supplied with two $\text{\O} 5.2$ mm pre-punched holes at 50 mm centres at each panel locking position.

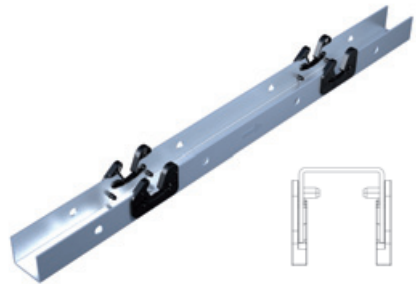

Modular click rail SE

The modular click rail SE is a Structurally Effective support rail i.e. it can be used independently as a spanning element. The spanning capacity must be calculated by a structural engineer. It does not have pre-punched holes for fixing as the fixing position is not necessarily at the panel locking positions.

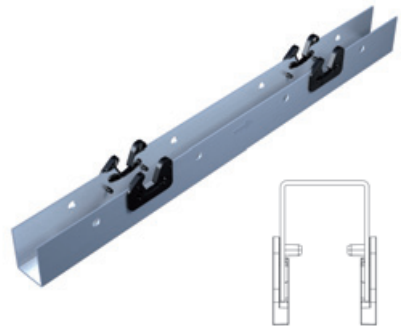

Modular click rail SEL

The SEL 40 provides a Structurally Effective rail with an integrated web for ease of fixing to standard L-profile wall brackets. The spanning capacity must be calculated by a competent structural engineer.

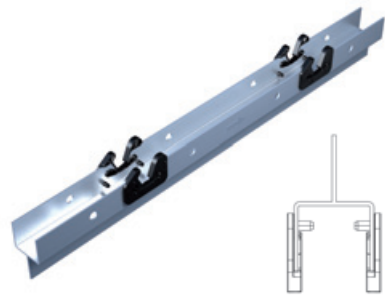

Plastic inserts

The plastic inserts are supplied pre-fitted to mono-click brackets and modular click rails. Due to the panel locking geometry the inserts are provided for left and right sides of the rail or bracket. When correctly installed the embossed arrow indicates the upward direction. The insert is also provided with a marking for convenience of alignment using a laser level. The laser level line also corresponds to the centre of the panel gap.

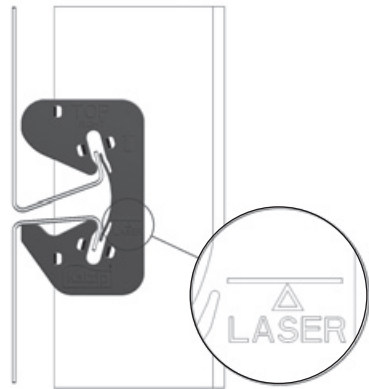

Setting out tool

The setting out tool is used to accurately join together adjacent modular click rails. Made from stainless steel, the adjustable pins can be moved up or down to accommodate the full range of standard panel cover widths. When the next rail is fixed in position, the setting tool can then be removed. See section 5.7 for detailed installation instructions.

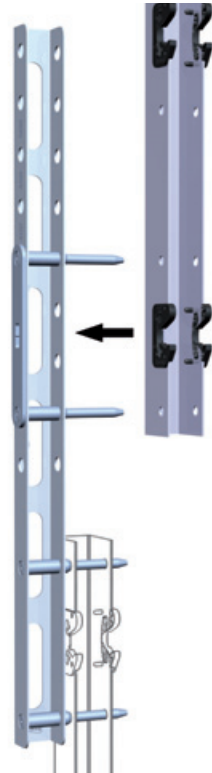

Fixed-point clamp

The fixed-point clamp is used to secure the panel at a single position either at the middle or the end of the sheet. Every FC panel must have a fixed point at a single position. See section 6.4 and 6.5 for detailed installation instructions.



Guidance snapper

The guidance snapper is designed to ensure a constant gap between adjacent panels. See section 4.2 for information on use of the guidance snapper with straight panels (single- and triple-span). The guidance snapper is also used on internal and external corner panels to ensure correct alignment. See section 6.6 for detailed installation instructions for corner panels.

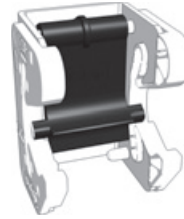

Flashing support

The flashing support clips into the modular click rails without the need for additional mechanical fasteners. It ensures a consistent, level surface is provided to which flashings can either be screwed or riveted. See section 7 for detailed installation instructions.

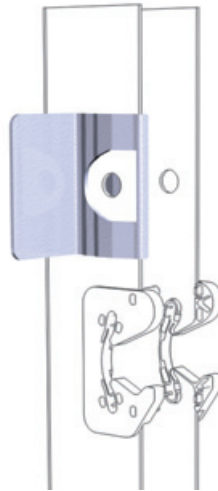

3.0 Transport, storage and handling

Transportation of panels to site

As standard, FC panels are transported by road up to a maximum length of 10 m. The panels are packed in pairs up to a maximum of 25 pairs per row. The table below gives maximum pack sizes for different FC panel cover widths.

Cover width (mm)	No. rows	Max. no sheets
250	4	200
300 – 350	3	150
400 – 500	2	100

System components and accessories are packed as follows:

Modular click rails

Modular click rails are supplied in standard lengths of approximately 3 m on wooden pallets and wrapped in a protective plastic film. The maximum pallet size is 1.2 m width x 1.2 m height.

Fixed point clamp

The fixed point clamp is supplied as standard in boxes of 100 with a 3 mm Allen tool included for locking and unlocking the clamp.

Guidance snapper

The guidance snapper is supplied as standard in boxes of 100.

Unloading of panels on site

The maximum pack weight for 10 m length sheets is 2.0 t. Make prior arrangements for lifting gear such as cranes, fork lift trucks, spreader beams, sling belts, etc. Protect the edges of pallets if sling belts are used.

Access to the unloading point must be guaranteed, this applies for all deliveries. Before delivery, the person who has placed the order must check the site and it may also be necessary for the transport agent to check the route. Delivery dates must be agreed with the supplier.

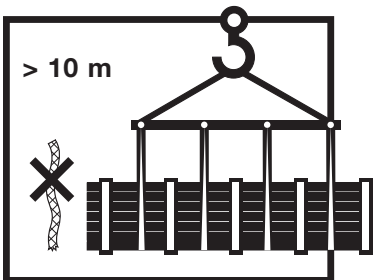
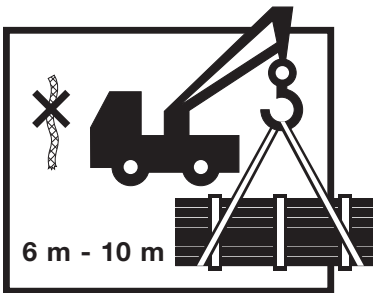
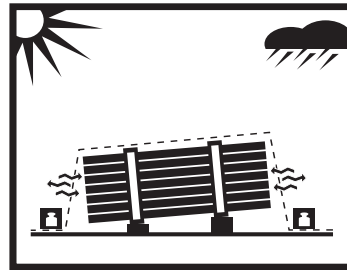
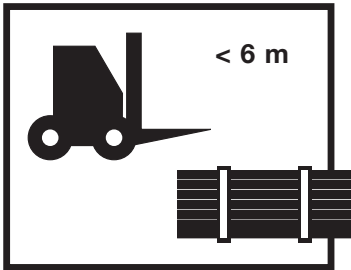

Panel storage

Panels should be stored under cover to prevent accumulation of dirt and condensation. Otherwise store at an angle on cross bearers and cover to allow air circulation.

Unpacking panels



Exercise care when opening packages stored at an angle. There is a risk of panels sliding sideways and/or in the direction of slope. When removing packaging from the panels with a knife, take care not to scratch the painted surface of the panels.

Panel protective film

FC panels are supplied with a protective polyethylene film. This should be peeled back from all panel edges before installation. The film can be temporarily kept on the panels to protect them from contamination from other works. In any case the film should be removed completely within three weeks of installation.

Checking incoming materials

Obtain confirmation of any material and packaging deficiencies from the forwarder and notify the supplier immediately.

Check that the number of packages and their contents agree with the delivery documents. Inform the supplier immedi-

ately of any discrepancies in dimensions or quantities etc. Any damage occurring during transport must be reported before installation. Claims for damaged goods will not be accepted after installation. All claims must be made within one week of arrival on the building site.

Panel handling

Suitable protective gloves should always be worn when handling FC panels. When carrying individual panels on-site, make sure to keep them in an upright position.

4.0 General information

Before commencing with installation of the FC façade system, this chapter should be read in its entirety. It contains two sections giving key infor-

mation on sub-construction tolerances and panel support requirements which applies to all sub-construction variations and panel cover widths.

4.1 Sub-construction requirements

Installation of the Kalzip FC façade system is achieved in combination with a suitable sub-construction system (see section 5). The sub-construction system must be capable of accommodating building tolerances to ensure that the supporting elements are plane and level to within the tolerances given in this section. These requirements are divided into a number of specific criteria, all of which must be met.

1. Over a complete length of an FC panel, no mono-click bracket or modular click rail must be positioned more than 1.5 mm from the datum line.

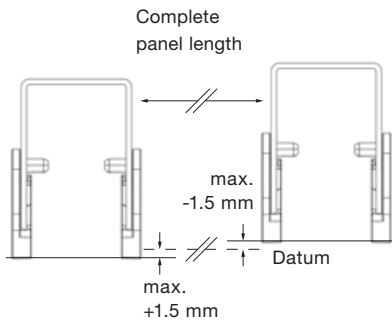

In-plane alignment

Three conditions for the plane alignment of modular click rails or mono-click brackets must be satisfied.

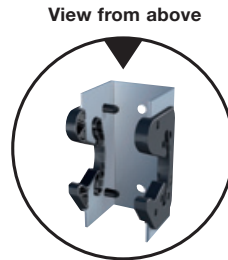

2. Horizontally adjacent mono-click brackets or modular click rails must be aligned within 1.0 mm of each other (independent of the distance between them).

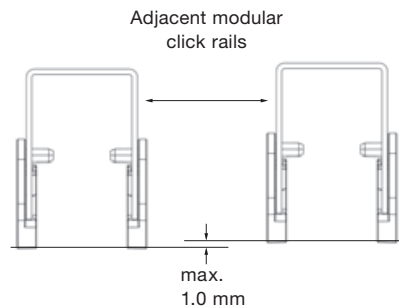

- 3. Vertically adjacent mono-click brackets or modular click rails must be aligned within 1.0 mm of each other.

View from side

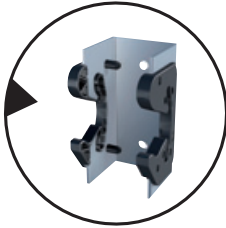

Panel cover width

The distance between panel locking points in vertically adjacent mono-click brackets or modular click rails must be within ± 0.5 mm of the nominal panel cover width. See section 5.7 for information on using the modular click rail setting out tool.

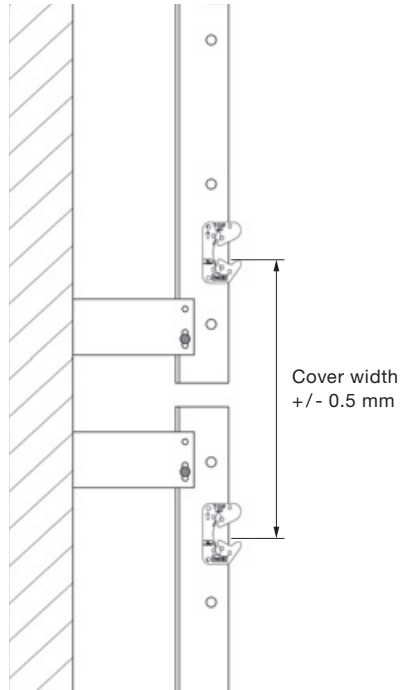
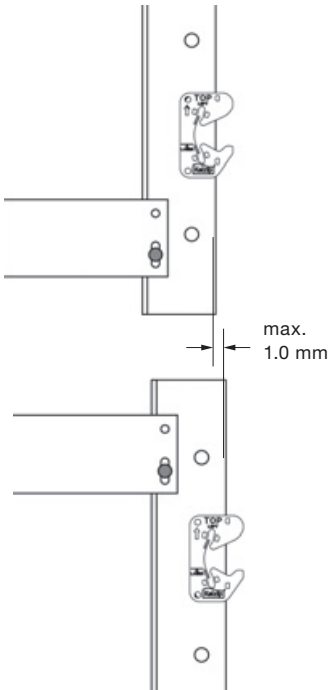

Height alignment



Note

Do not use the top of the modular click rails to take measurements – always use the laser markings on the plastic inserts to check the height alignment.

Over a complete FC panel length, the maximum deviation from the datum level must not exceed 1.5 mm.

Between adjacent modular click rails or mono-click brackets, the difference in height must not exceed 1 mm (independent of rail spacing).

View from front

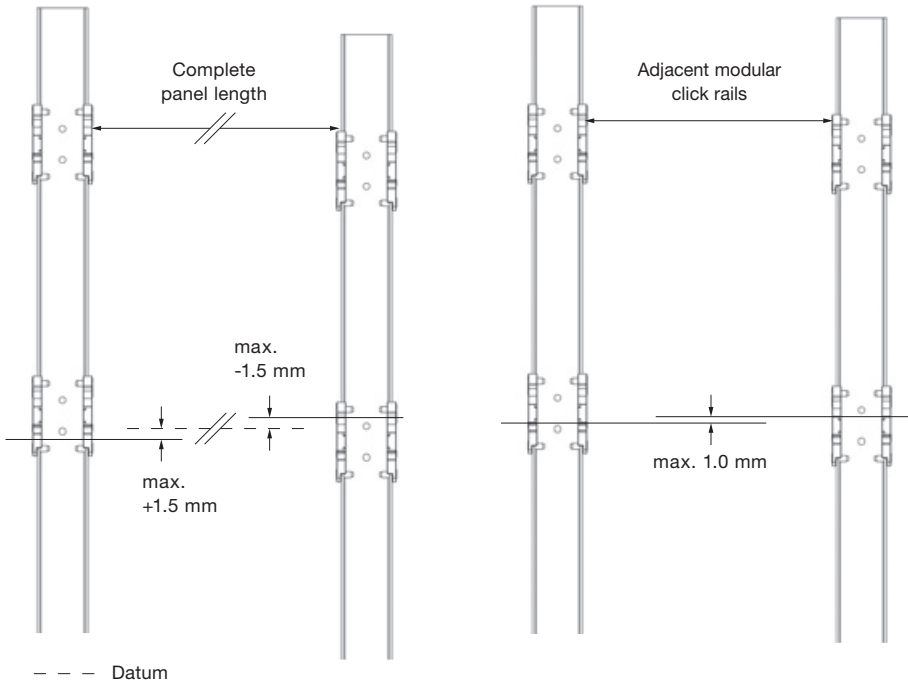
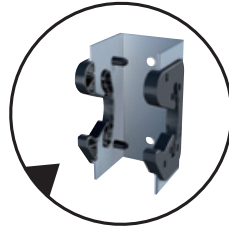

Vertical alignment

Over a 3 m distance, the alignment of modular click rails or mono-click brackets must be within ± 5 mm of the vertical.

View from front

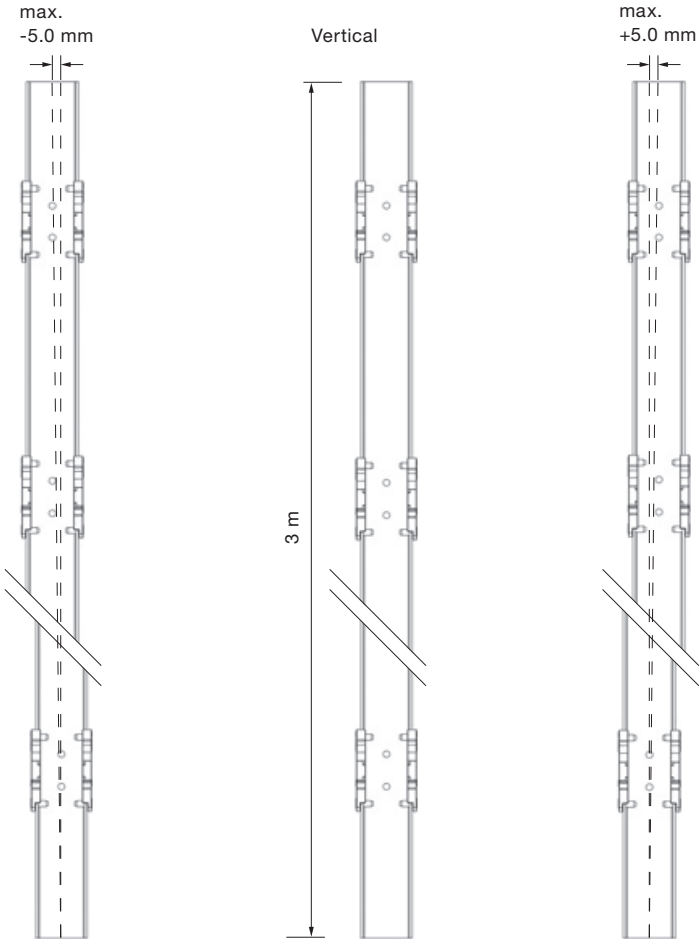
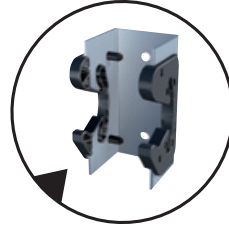

Rotational alignment

The modular click rails or mono-click brackets must be aligned to within the tolerance shown below.

View from top

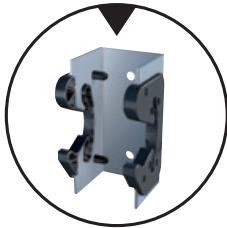

View from side

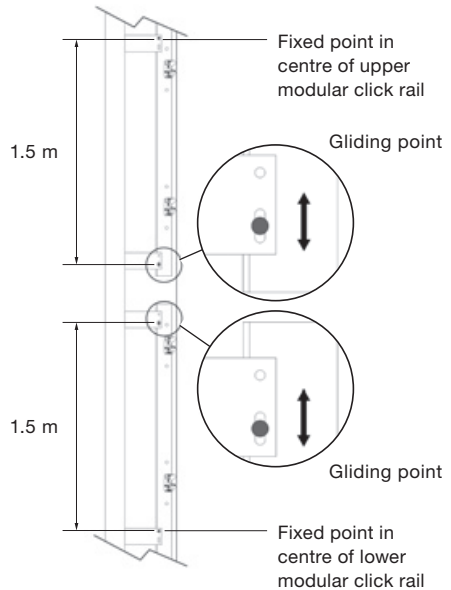
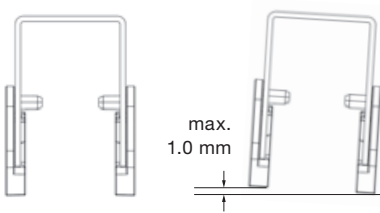
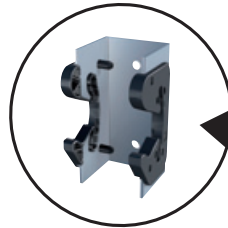

4.2 Panel support requirements

This section gives an overview of the panel support requirements. Section 6.3 gives further information on vertical panel joints.

Panel overhangs

To ensure sufficient room for the installation of flashings (either directly on the sub-construction or using the proprietary flashing support) the minimum distance between the centre of the panel locking area and the edge of the panel is 80 mm. The maximum allowable panel overhang is 20% of the panel span.

Minimum joint width

All vertical panel joints must be a minimum of 10 mm width. This is to ensure there is sufficient space for the panels to expand and contract. For panels longer than 10 m, 1 mm per linear metre gap should be allowed.

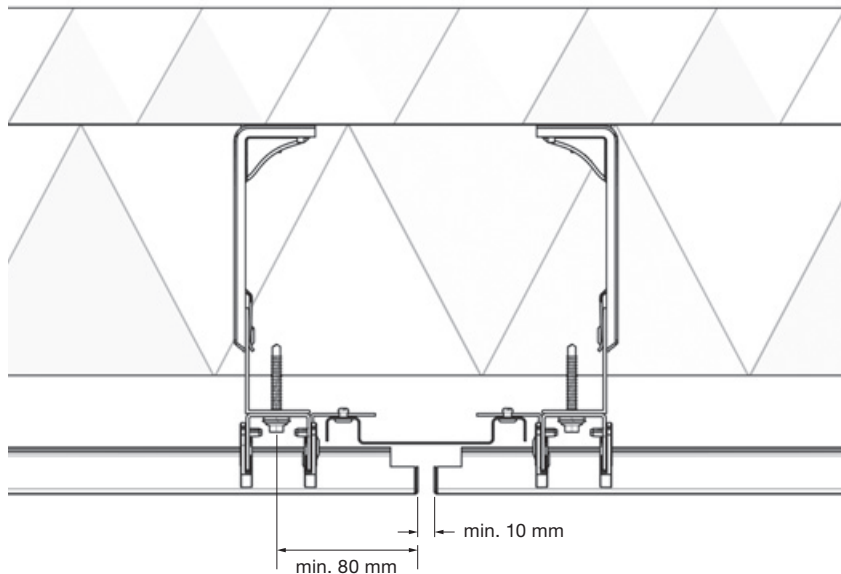



A single mono-click bracket or modular click rail must never be used to support two FC panels.

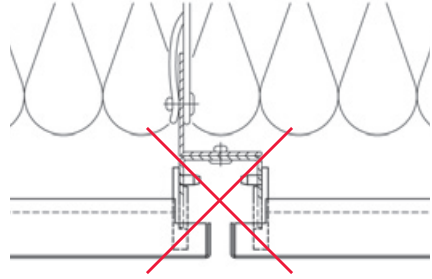

Maximum panel span

The maximum panel span (distance between adjacent panel supports) is limited to 1.60 m independent of structural performance.

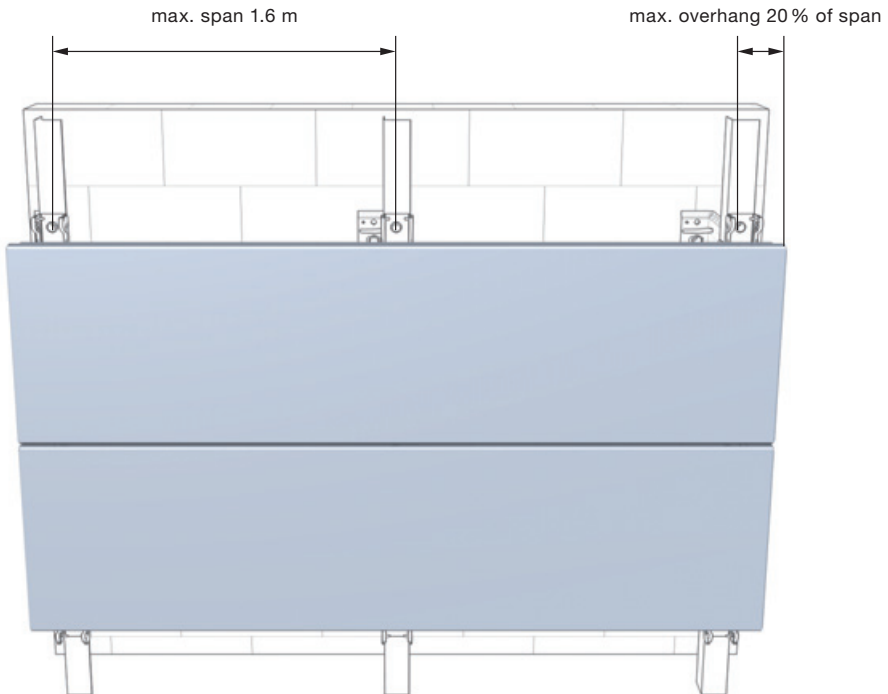

Single and triple-span supports

In situations where the FC façade panel is supported in a single span configuration, the panel must be fitted with a guidance snapper adjacent to the fixed point clamp. In a triple span configura-

tion, it is also recommended to install a guidance snapper adjacent to the fixed point clamp. For double and multiple span configurations, a single fixed point in the middle of the panel is sufficient.

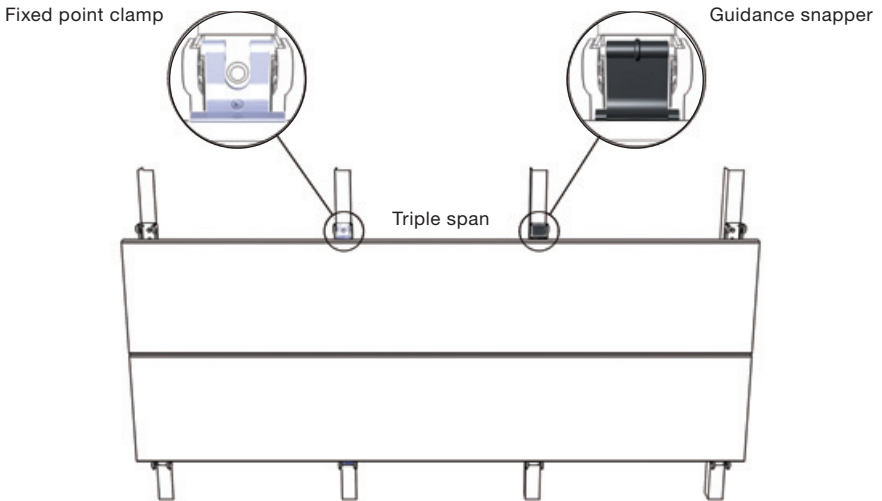
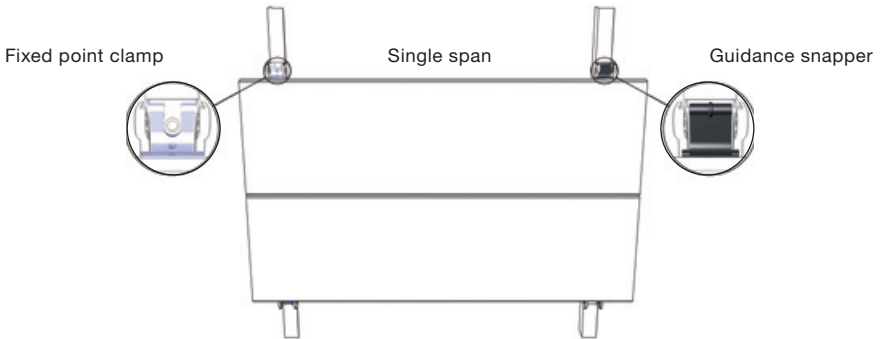

Corner panels

Corner panels should be installed with a fixed point between 80 mm and 100 mm from the corner of the panel. For corner panels with unequal length sides, the fixed point should be installed on the long side of the panel. Guidance snappers must be installed at both ends of all corner panels, whether they have unequal sides or not. See section 6.6 for further information on corner panel installation.

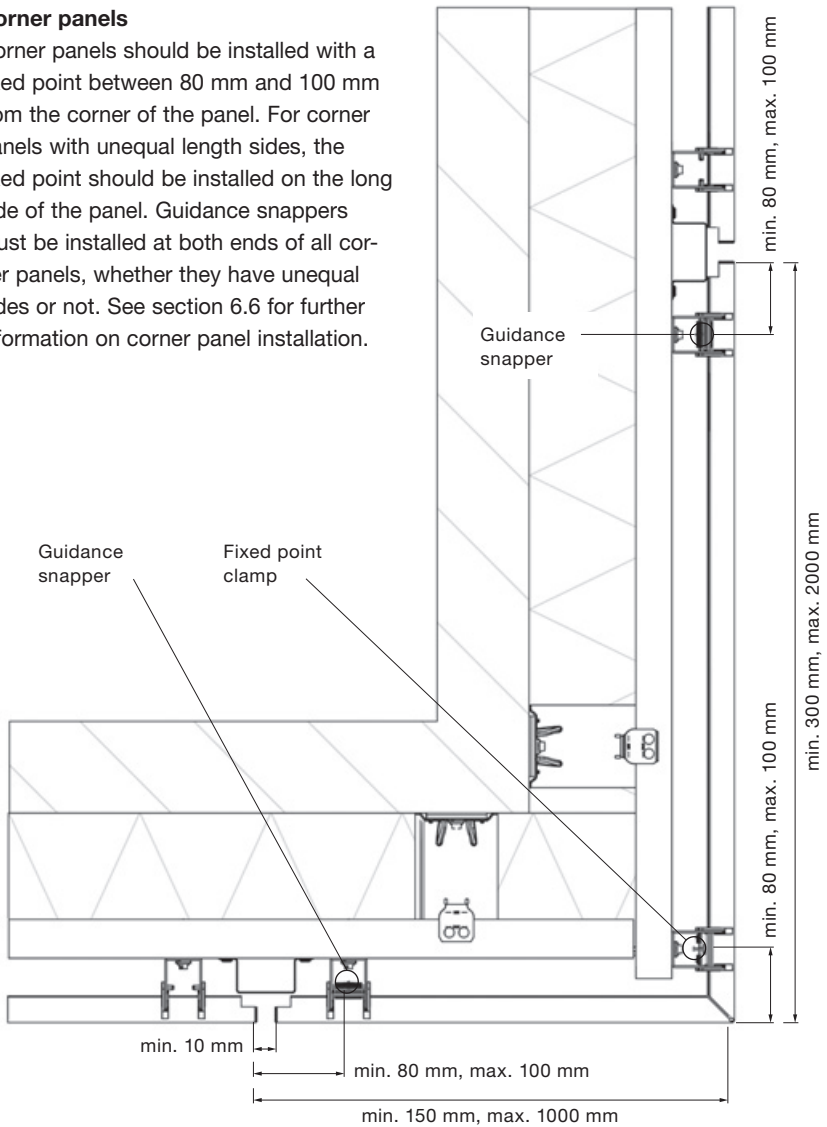

5.0 Sub-construction installation

The Kalzip FC façade system must be installed on an adjustable sub-construction system. This is required to ensure a plane, level surface for supporting elements. It also provides a cavity for wall insulation and an air

gap for drainage and ventilation. This chapter gives an overview of six different variations on a range of types of back wall. The type numbering follows the same sequence as the 2D construction details.

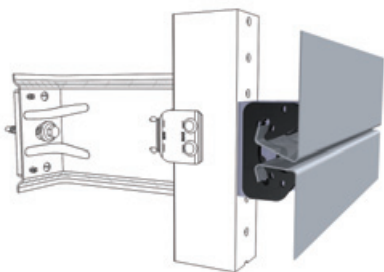

1. Mono-click brackets on vertical rails

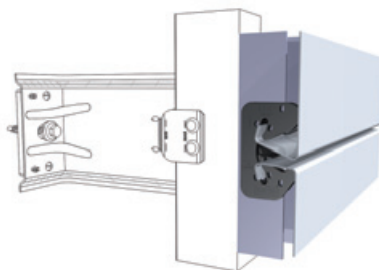

2. Modular click rail NE on vertical rails

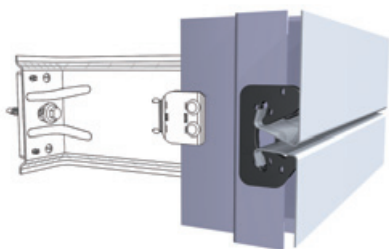

3. Modular click rail SEL on L-brackets

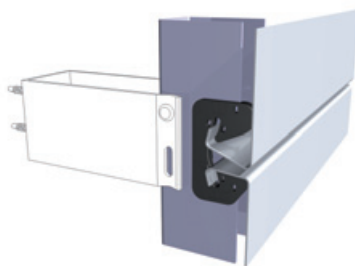

4. Modular click rail SE on U-brackets

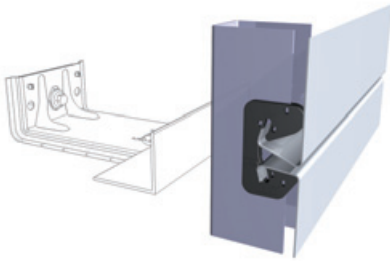

5. Modular click rail SE on horizontal rails

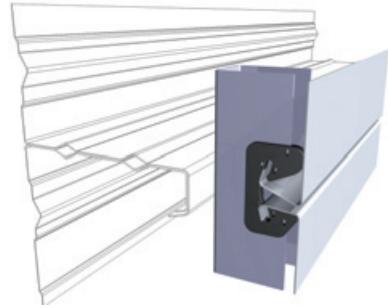

6. Modular click rail SE on structural cassette

5.1 Mono-click brackets on vertical rails

A vertical L-profile rail is fixed to the backing wall with adjustable wall brackets. The rail can be supplied with pre-drilled modular holes for easy fixing of the mono-click brackets. This is particularly useful for installing panels with different cover widths quickly and easily.

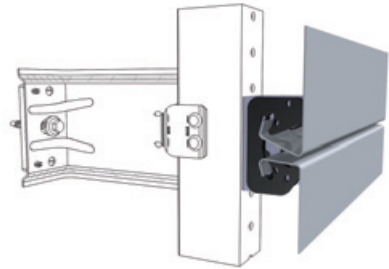

Support rails with pre-drilled holes

Using this variation, the plane and level alignment of the sub-construction is carried out in a single step. The vertical rails must be fixed accurately for the modular holes to line up.

Adjust the rails to the in-plane, height, vertical and rotational alignment tolerances specified in section 4.1. Check the distances A, B and C are correct according to the project drawings.

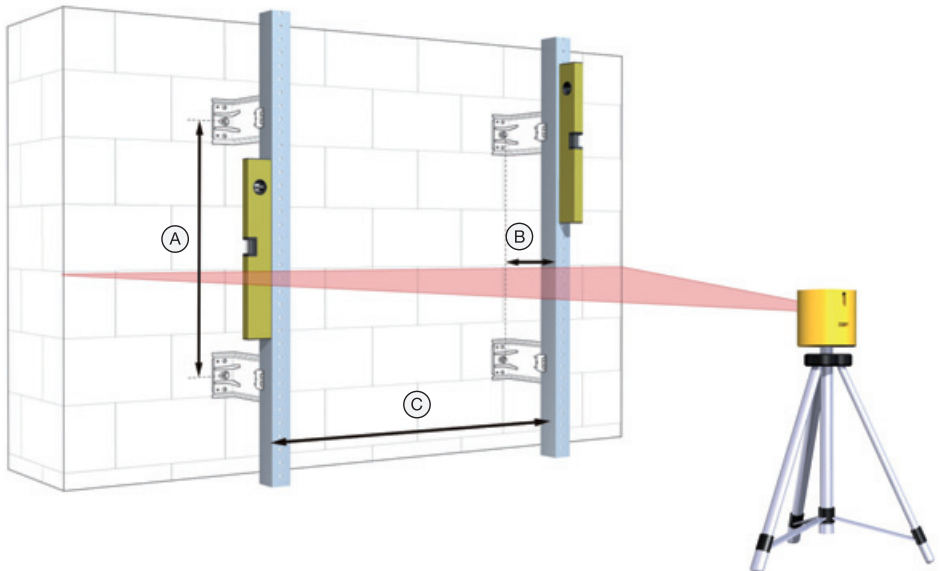

Mono-click brackets can now easily be fixed in the modular holes with rivets. The $\text{\O} 5.2$ mm holes are set at 50 mm centres to correspond with the holes in the mono-click bracket.



Note

Every mono-click bracket must always be secured with two rivets. One fixing per mono-click bracket is not sufficient to prevent it rotating.



Note

The position of the holes in the mono-click bracket is not related to the position of the gap between two FC panels. Always use the laser marking on the side of the plastic insert as the height reference.

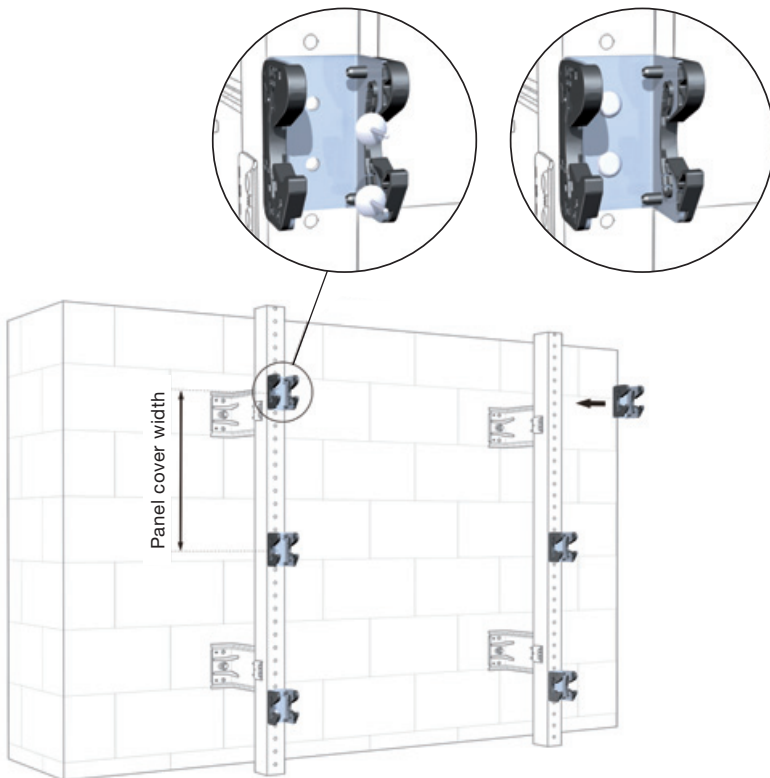

5.2 Modular click rail NE on vertical rails

The modular click rail NE is fixed to vertical support rails. Use of this system allows adjustment to be made in two subsequent steps and provides an easy-to-install solution with standard wall brackets.

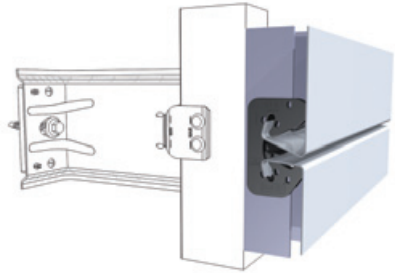

Vertical support rails

The vertical rails (e.g. L-profiles) must first be accurately aligned in the plane of the back wall. Adjust the rails to the in-plane, vertical and rotational align-

ment tolerances specified in section 4.1. Check the distances A, B and C are correct according to the project drawings.

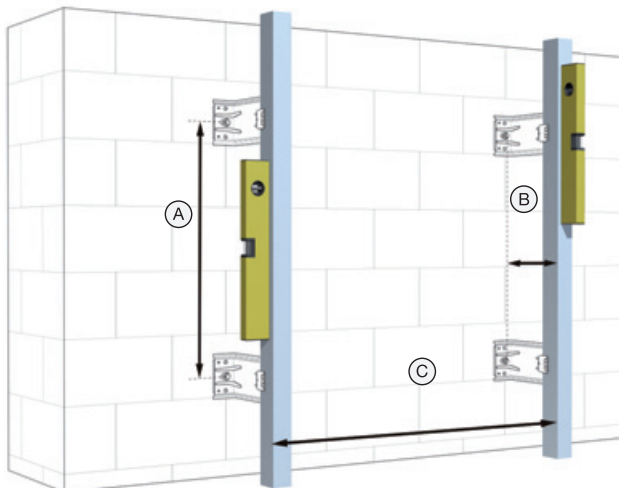

Fixing modular click rail NE

Align the modular click rails on the vertical support rails and adjust the height accurately with a laser.



Note

The modular click rail NE must be fixed at every panel locking position.

Two pre-punched $\text{Ø } 5.2 \text{ mm}$ holes are provided in the modular click rail NE for rivets or screw fixings. The number of fixings must be installed according to the project structural design calculations and drawings.

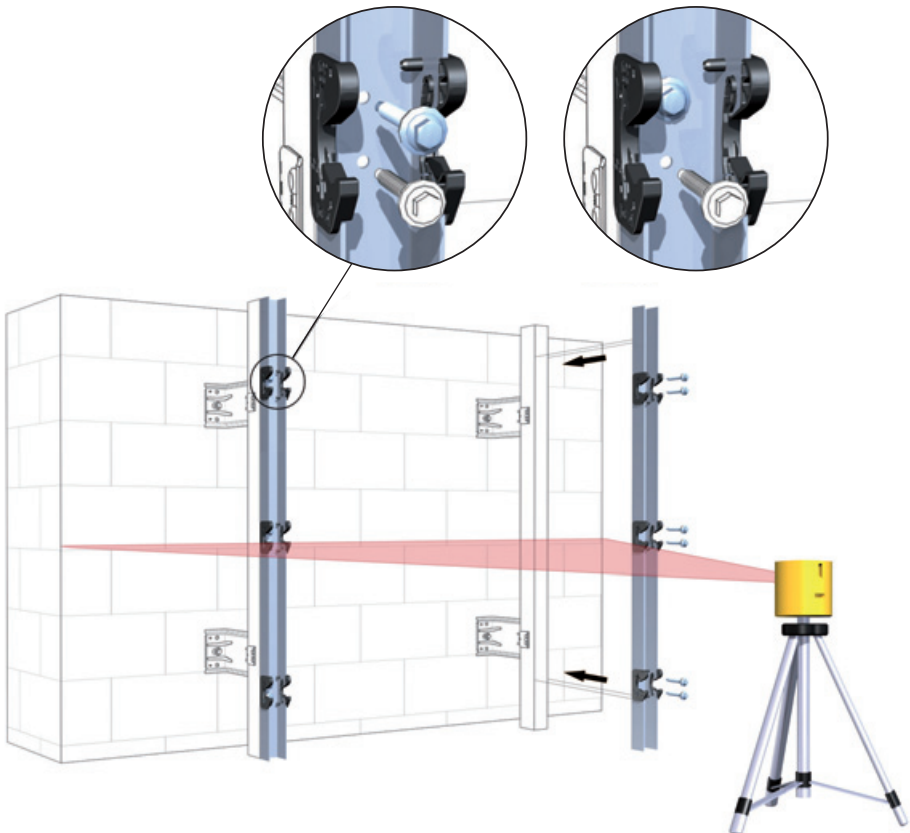

5.3 Modular click rail SEL on L-brackets

The modular click rail SEL is a structurally-effective vertical support rail compatible which can be fixed directly to standard wall brackets. Alignment of this sub-construction variation, using only two components is carried out in a single step.

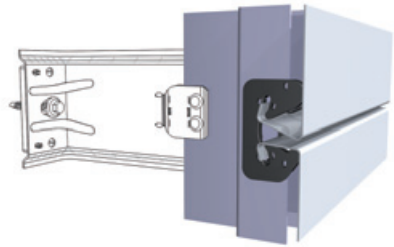

Installation procedure

Install the SEL modular click rail onto standard wall brackets. Using this system, the alignment of the sub-construction is carried out in a single step.

Adjust the rails to the in-plane, height, vertical and rotational alignment tolerances specified in section 4.1. Check the distances A, B and C are correct according to the project drawings.

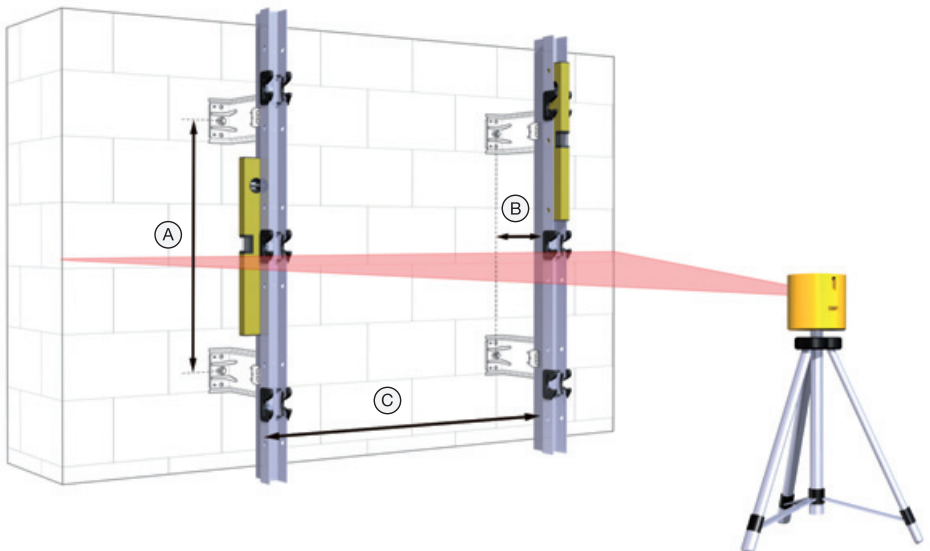



Note

To make the sliding point effective, a spacer pad must be used with the rivet gun to ensure the rail is free to expand and contract.

Fixed point

One or two rivets or screws (according to structural requirements) fixed in circular holes.

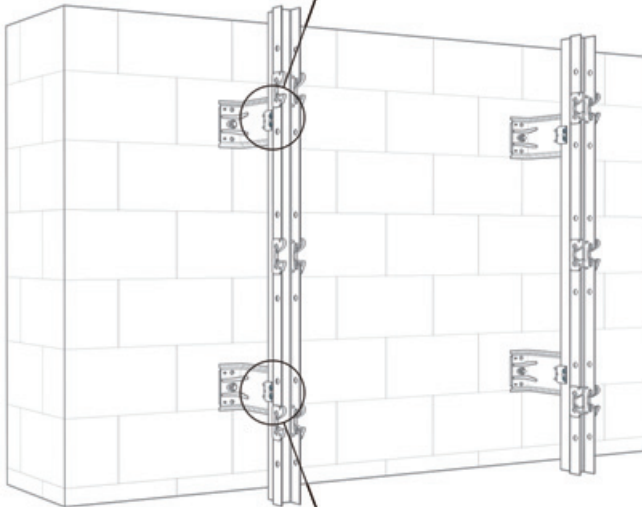
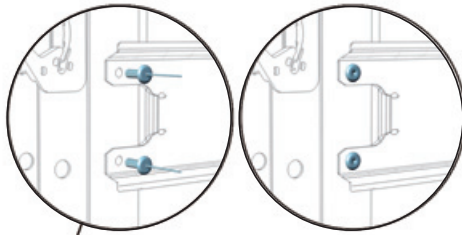

Sliding point

One or two rivets or screws (according to structural requirements) fixed in slotted holes.

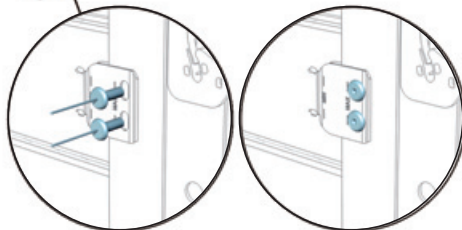

5.4 Modular click rail SE on U-brackets

The structurally effective modular click rail (SE) can span between U-profile wall brackets, providing an economical solution using only two components.

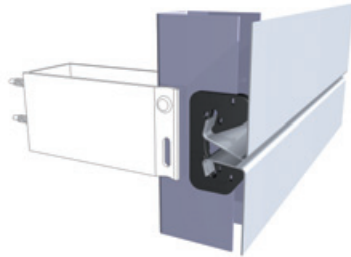

Installation procedure

Install the modular click rail SE onto U-profile wall brackets. Using this system, the alignment of the sub-construction is carried out in a single step. Adjust the modular click rails to the in-

plane, height, vertical and rotational alignment tolerances specified in section 4.1. Check the distances A, B and C are correct according to the project drawings.

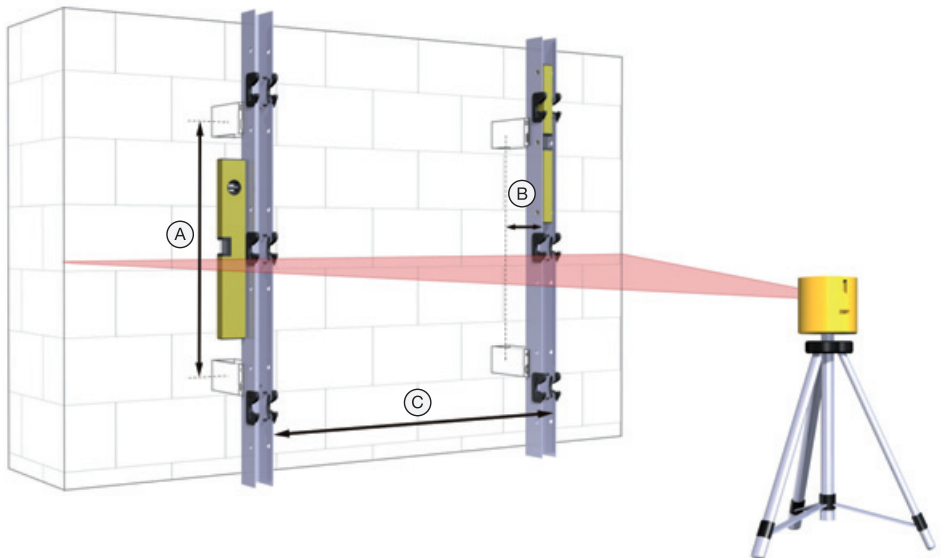



Note

To make the sliding point effective, a spacer pad must be used with the rivet gun to ensure the rail is free to expand and contract.

Fixed point

Rivets or screws fixed in circular holes (on **both** sides).

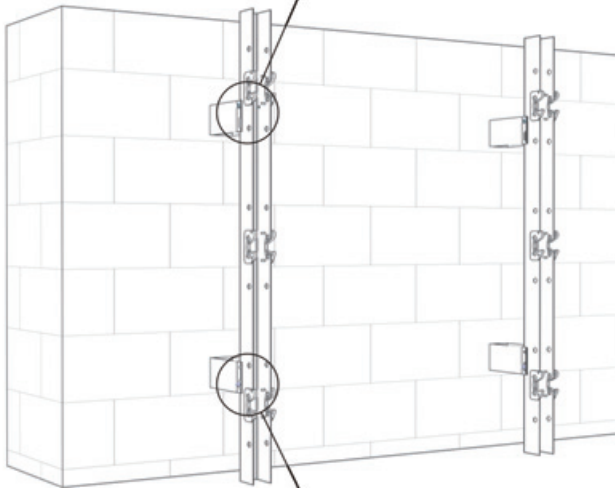
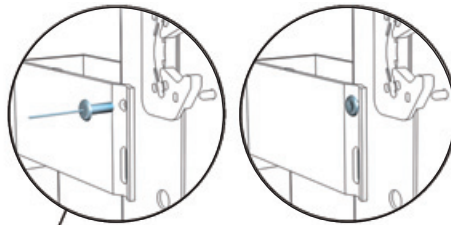

Sliding point

Rivets or screws fixed in slotted holes (on **both** sides).

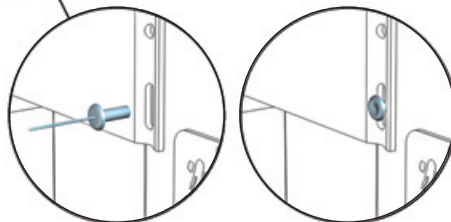

5.5 Modular click rail SE on horizontal rails

Using horizontal rails fixed to adjustable wall brackets simplifies the installation procedure by splitting the alignment of the modular click rails into two steps – alignment in the plane of the back wall followed by height and vertical alignment.

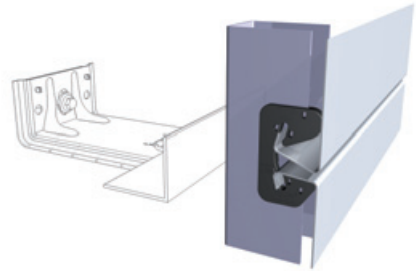

Installation procedure

Install the horizontal rails onto standard adjustable wall brackets. Adjust the in-plane alignment of the horizontal rails

to the tolerances specified in section 4.1. Check the distances A, B and C are correct according to the project drawings.

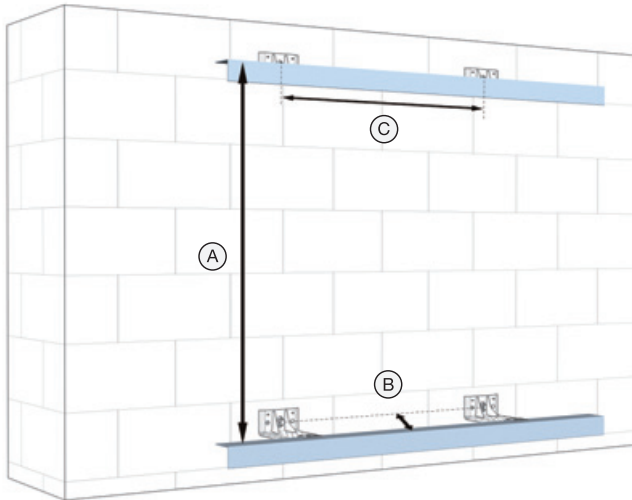

The modular click rail SE can be fixed to the horizontal rails with self drilling/tapping screws or with rivets.



The number of fixings must be installed according to the project structural design calculations and drawings.

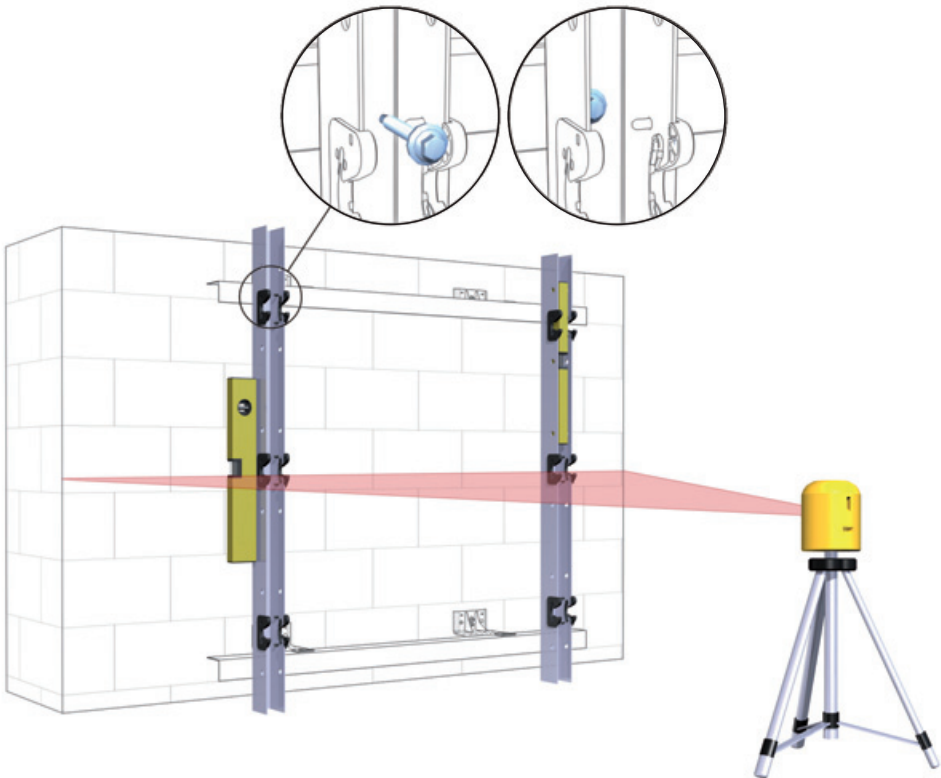

5.6 Modular click rail SE on structural cassette

For installation on steel structural liner trays, the structurally effective modular click rail is fixed directly to the top flanges to accommodate the difference between the FC panel cover width and the cover width of the cassettes.

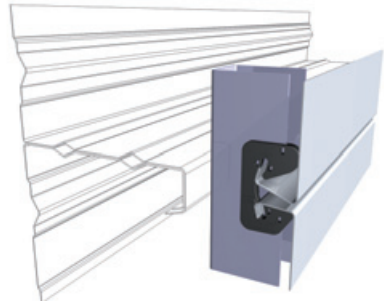

Installation procedure

Using this variation – without an adjustable sub-construction – it is essential that the structural cassettes themselves provide a plane and level surface on which to install the modular click rails. Any discrepancies in alignment must be accommodated by shimming the rails

as required. Using structural cassettes as the back wall, the maximum spacing between modular click rails must be verified by the project structural engineer. The dead weight of the modular click rails and FC panels must be communicated to the building structure at the head of the façade or supported on

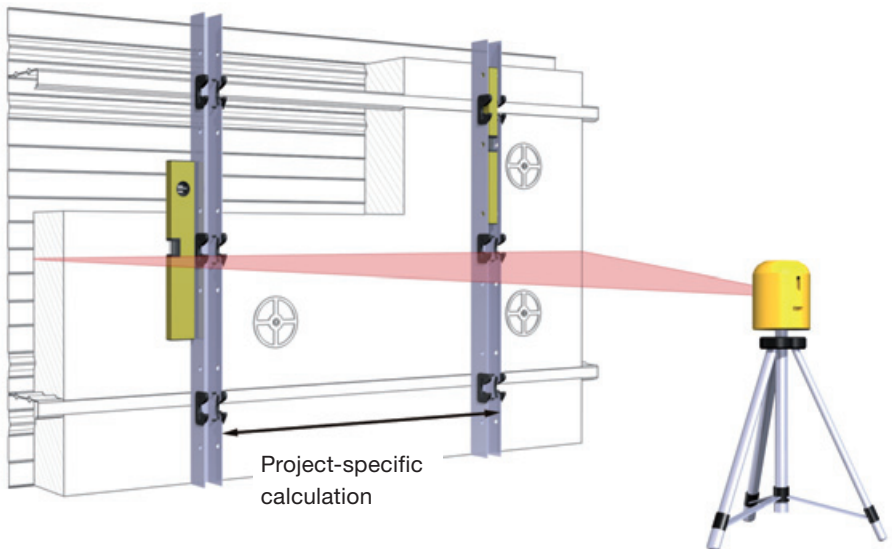

the ground at the base. Check the rails are aligned to the tolerances specified in section 4.1. The modular click rail SE can be fixed to the structural cassette with self drilling/tapping screws or with rivets. Care should be taken to ensure that there is a sufficient gap between vertically adjacent rails to allow for thermal movement.



Note

The number of fixings must be installed according to the project structural design calculations.

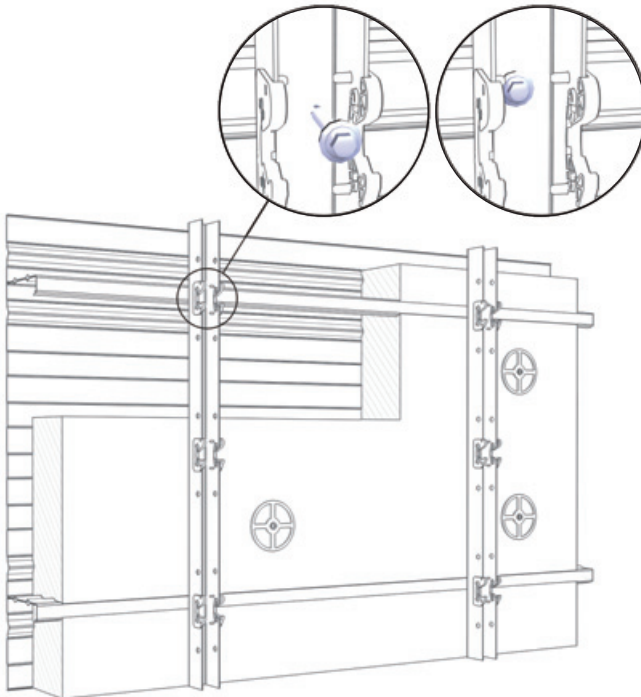

5.7 Modular click rail setting out tool

To allow for thermal expansion, all modular click rails are supplied in standard lengths of approximately 3 metre. The setting out tool allows accurate spacing at joins between vertical rails. The tool can be adjusted to accommodate every standard panel cover width.

Panel cover width adjustment

The setting out tool consists of a rail with two pairs of pins, one pair fixed and one pair adjustable. The tool is initially set to the 500 mm cover width position.

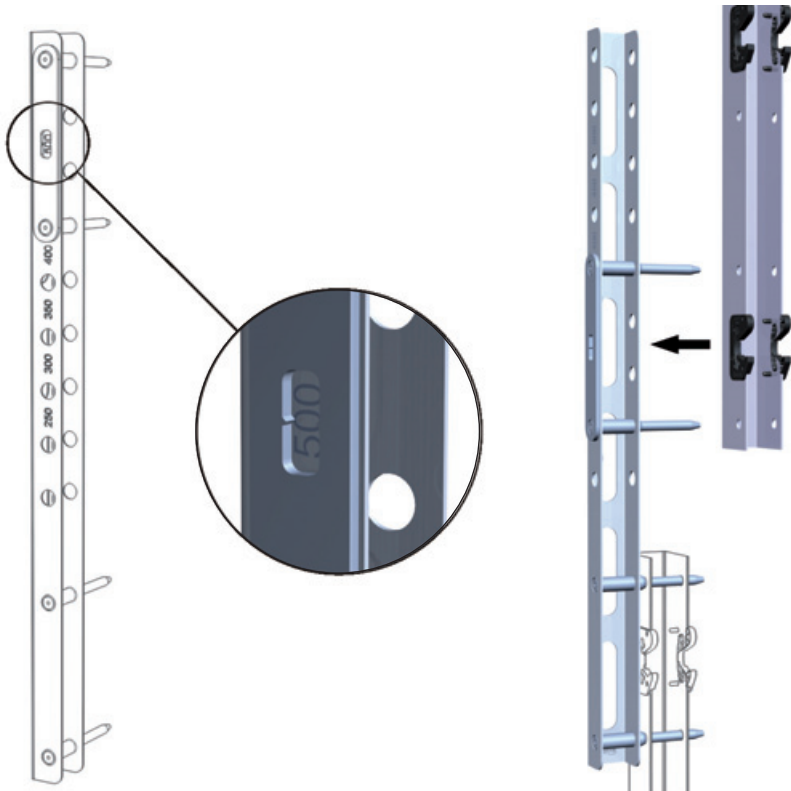

To adjust the setting out tool (1) to the required cover width, remove the two clips (2) holding the adjustable pins in place, pull the pins (3) out of the rail and relocate in the appropriate holes (4).

Replace the clips to secure the pins in their new position (5). The cover width set is shown in the window in the web of the adjustable pins (6). The sequence (1) to (6) below shows each step.

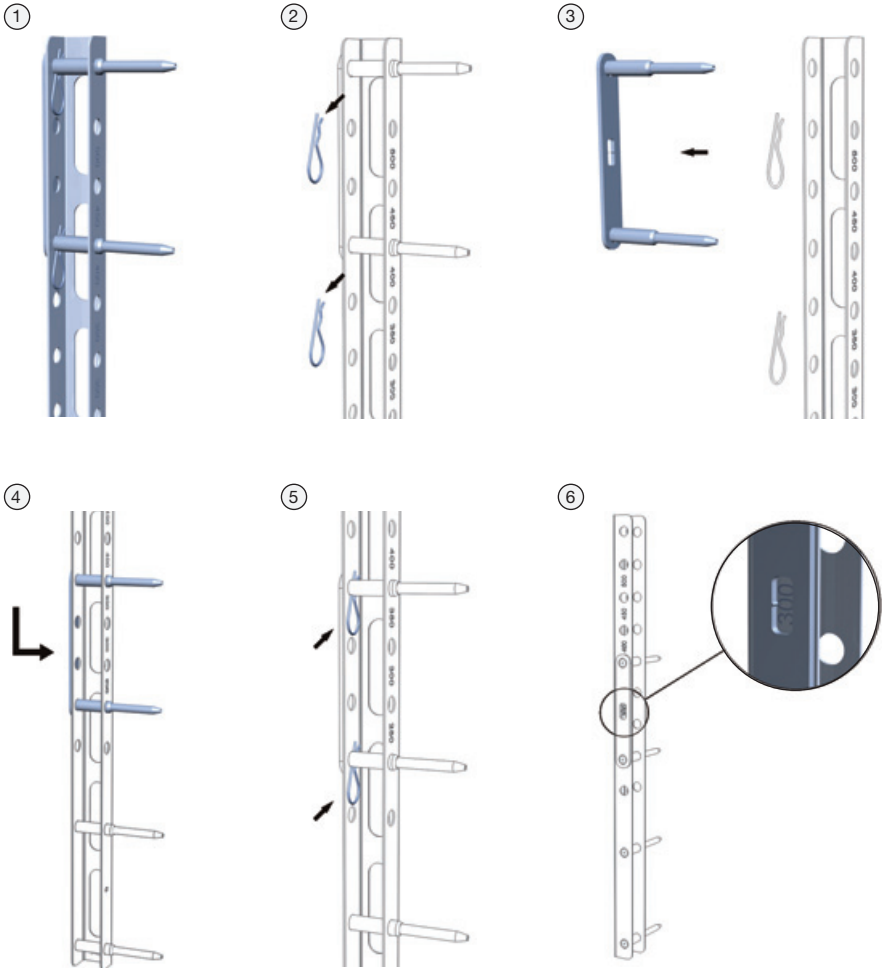

Setting out modular click rails

The modular click rails are provided with pre-punched holes in their sides to accept the setting out tool.

1. Align and fix the lower set of modular click rails according to the relevant sub-construction installation instructions given in section 5.

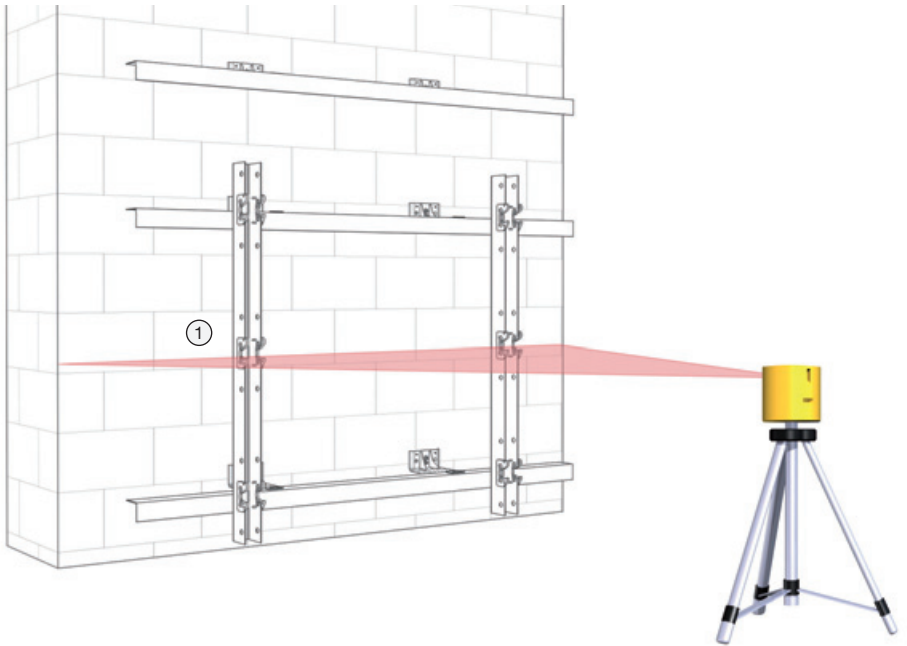

2. Insert the lower set of pins of the setting out tool into the top set of holes in the side of the bottom modular click rail.

3. Insert the bottom of the upper modular click rail into the top set of pins and check the alignment of the rail with a spirit level.

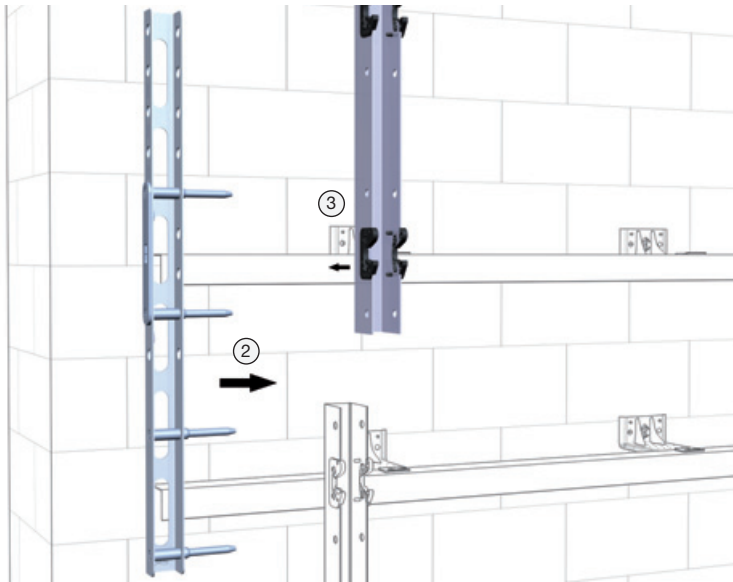

- 4. Double check that the correct panel cover width is showing in the window in the side of the tool and fix the top modular click rail in position.
- 5. Best practice is to start the next rail with the panel locking position fixed directly over a wall bracket or horizontal rails. The allowable overhang of any rails must be approved by the project structural engineer.

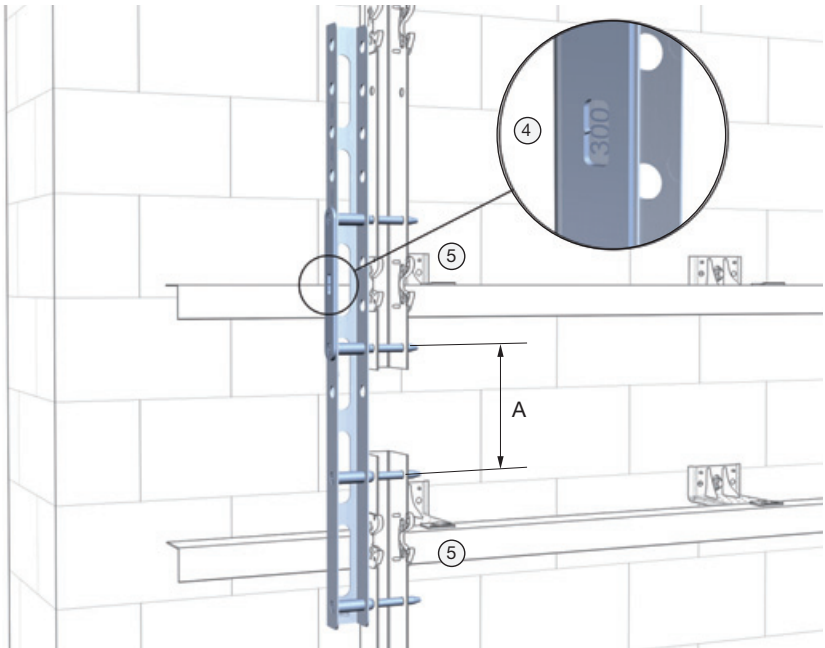

 **Note**

The gap, A, between adjacent modular click rails varies depending on the cover width of the panels.

6.0 Horizontal panel installation

The following sections illustrate the installation of FC façade panels in horizontally spanning applications. The design of the FC panel locking geometry permits the installation of panels in both directions (from bottom to top or from top to bottom).

Panel edge geometry

The top and bottom edges of the panel have a different geometry, so care must be taken to ensure the panel is installed the correct way up.

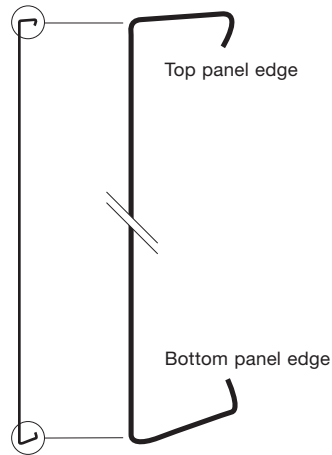

Correct panel installation

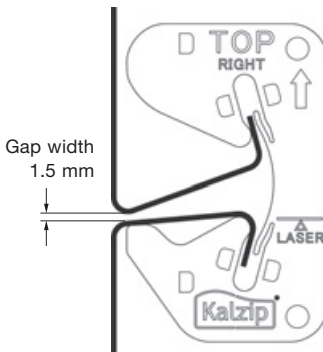

Never try to install the panels upside down.

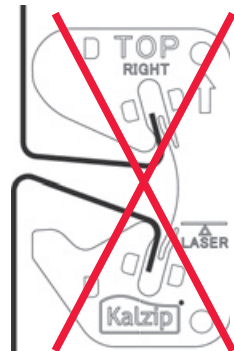

6.1 Panel installation (bottom to top)

This sequence shows the installation of FC panels from bottom to top. Refer to section 6.4 for making the fixed point.

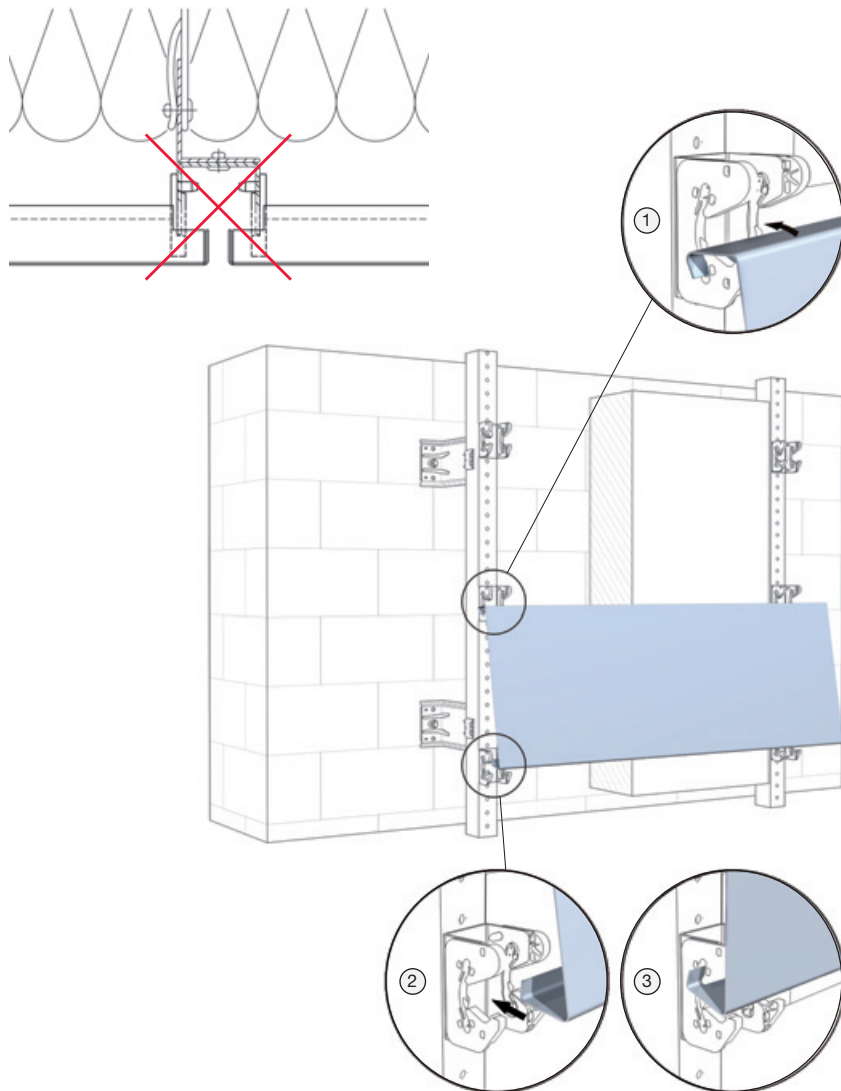

1. Hook the top edge of the first panel over **both** lower hooks of the mono-click bracket or modular click rail. Check that the panel can slide freely left to right.
2. Wearing gloves, use the palm of the hand to push the bottom edge of panel into the upper part of the bracket.
3. The bottom edge of the panel should click into place easily. Check again that the whole panel can slide freely left to right.



Note

The panel overhang has been reduced in these drawings for clarity only. Refer to the panel support requirements in section 4.2.



Stop

A single mono-click bracket or modular click rail must **never** be used to support two FC panels.



Caution

Always push the panel directly over the support bracket – not between the supports.

Never force the panel into position – this will damage the edges and may require panel replacement. If the panel does not click in easily, double-check the alignment of the sub-construction.

4. Make a fixed point in the lower panel (see section 6.4) before hooking the second panel in place above. For single and triple-span applications the guidance snapper must also be be installed at the positions shown in section 4.2.

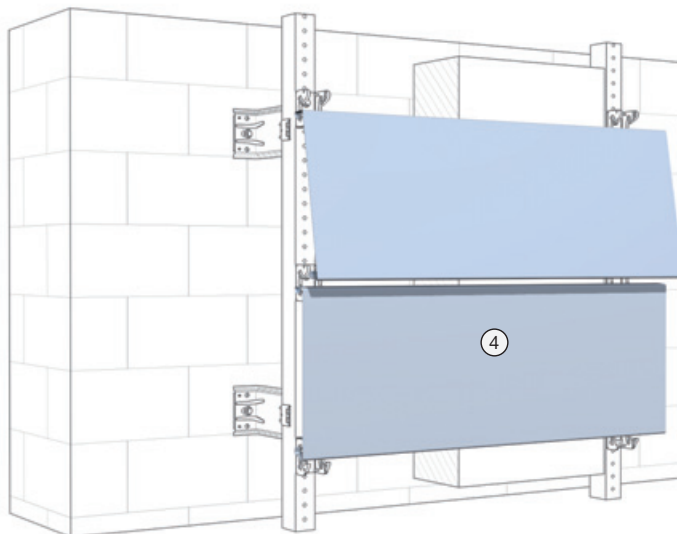

5. During bottom-to-top installation, each panel can be clicked directly into the mono-click brackets or modular click rails.

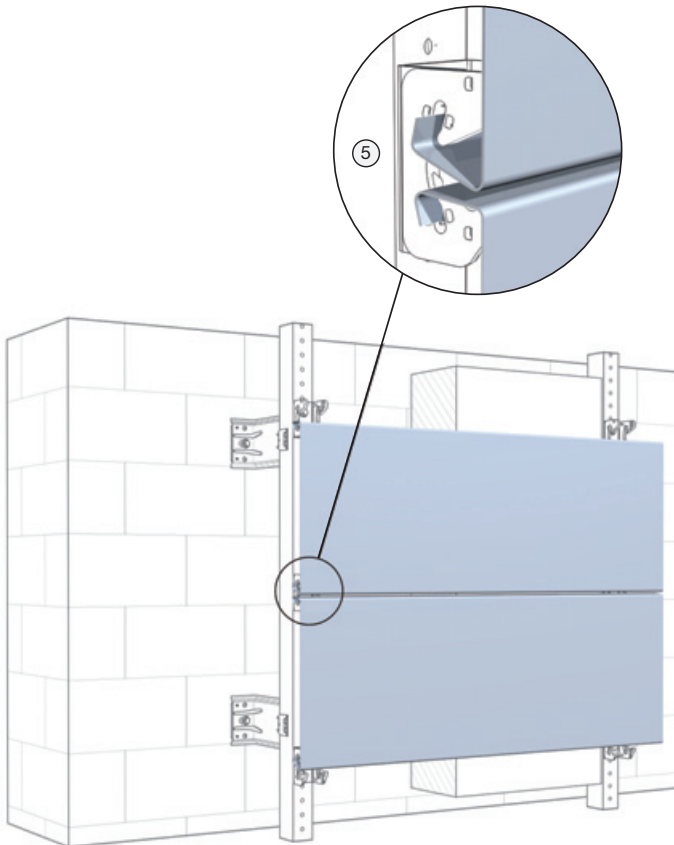

6.2 Panel installation (top to bottom)

This sequence shows the installation of FC panels from top to bottom. Refer to section 6.4 for making the fixed point.

1. Hang the top edge of the first panel over the lower hooks of the mono-click bracket or modular click rail. Check the panel can slide freely left to right.

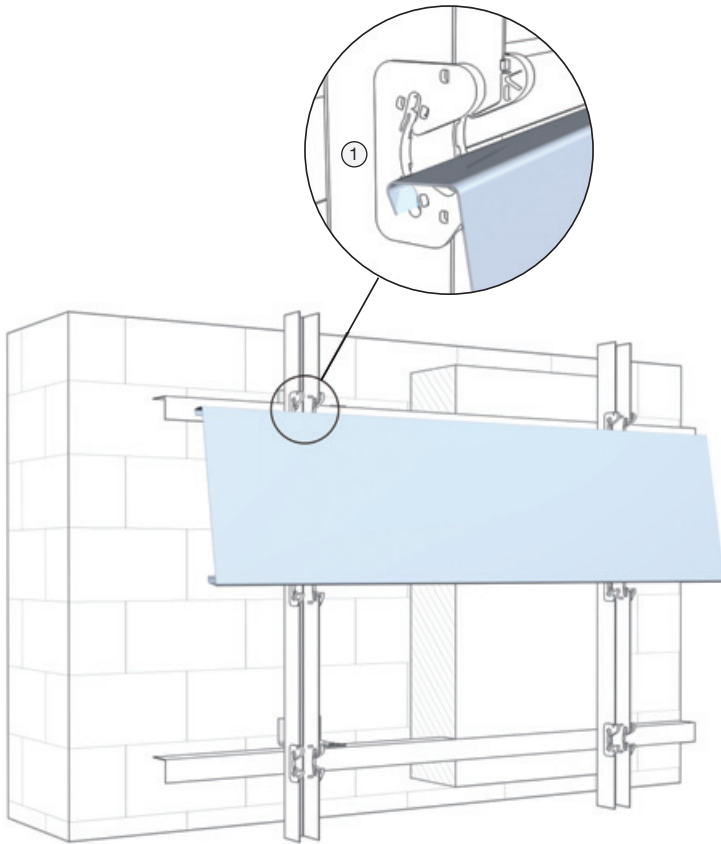

2. Hang the lower panel in place and make a fixed point in the upper panel (see section 6.4).



Caution

Do not click in the bottom edge until the lower panel has been hung in place and a fixed point has been made in the upper panel.

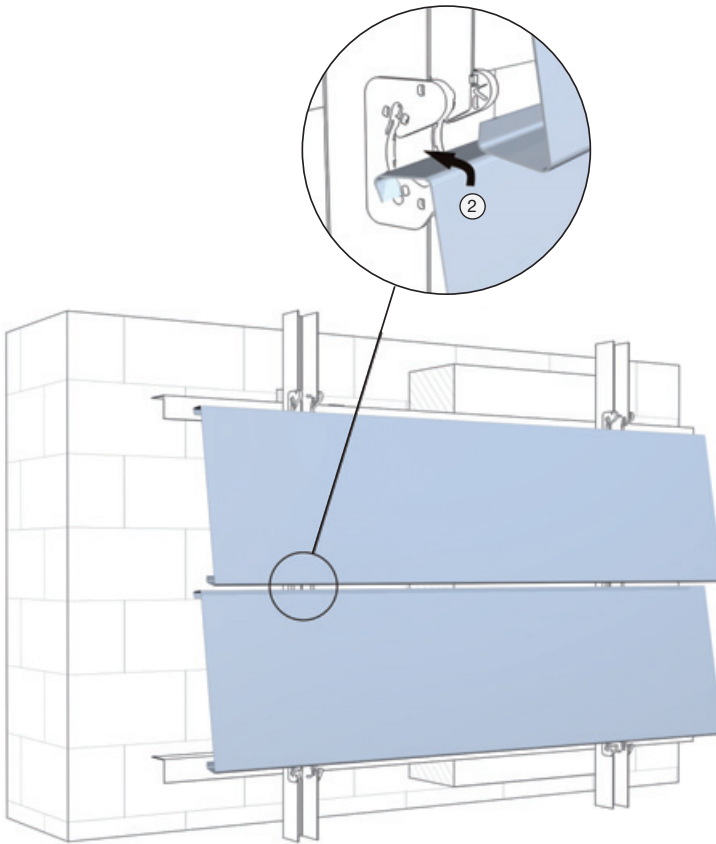

6.3 Vertical panel joints

Vertical panel joints are important for the appearance of the façade. This section should be read together with section 7 on flashing installation which gives a range of possible joint flashings.

Minimum joint width

All vertical panel joints must be a minimum of 10 mm width. This is to ensure there is sufficient space for the panels to expand and contract. For panels longer than 10 m, 1 mm per linear metre gap should be allowed.

Panel overhangs

To allow sufficient space for flashings to be fixed (either directly to the sub-construction or via the proprietary flashing supports) there should be a minimum of 80 mm distance between the centre of the supports and the edge of the panel. The maximum allowable panel overhang is 20% of the panel span.

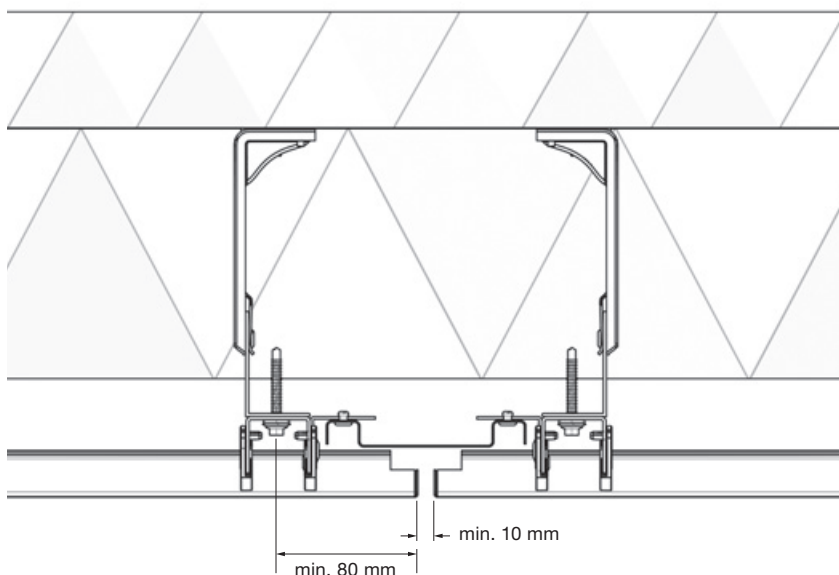

Panel joints with flashings

For vertical joints which include flashings separating the edges of adjacent panels, the minimum gap width should be 10 mm either side of the flashing.



A single mono-click bracket or modular click rail must **never** be used to support two FC panels.

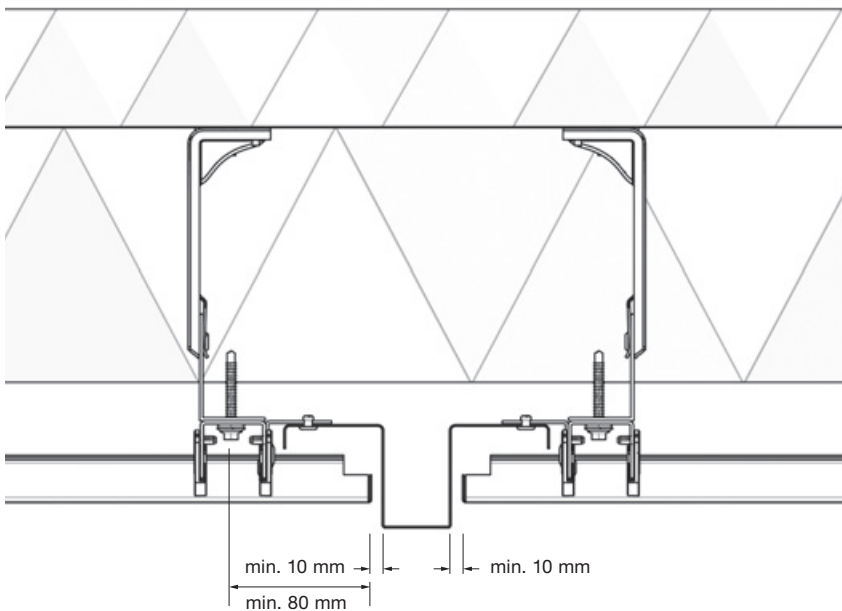
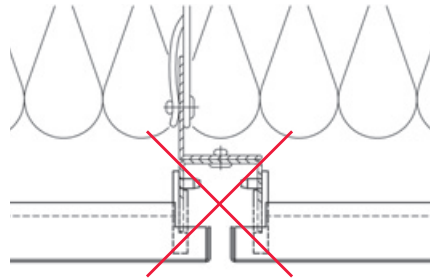

6.4 Fixed point

Every FC panel must have one fixed point. This is achieved using the proprietary fixed point clamp supplied with the system. The fixed point is normally positioned in the centre of straight panels and stops the panel from sliding out of position when expanding and contracting. For fixed points in corner panels see section 6.6.

Installation sequence

Before making a fixed point, check that the panel slides freely left to right in the supports. Make sure that the panel is in the correct position in relation to flashings or adjacent panels.

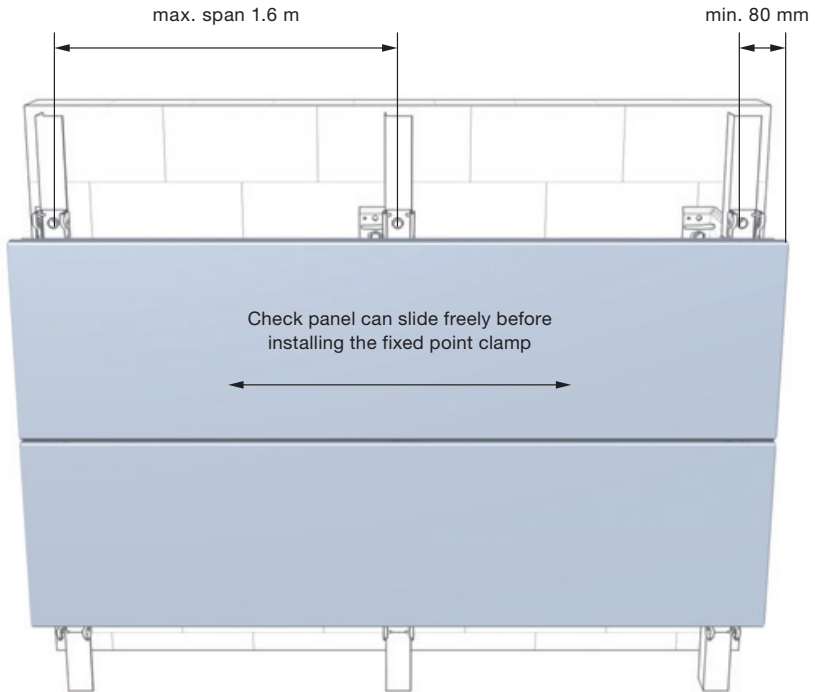

After the lower panel is installed, the fixed point clamp is inserted between the hooks of the mono-click bracket or modular click rails and clips over the

two pins in the top of the plastic inlays. When the clamp is in position, screw until hand-tight using a \varnothing 3 mm Allen head screwdriver.

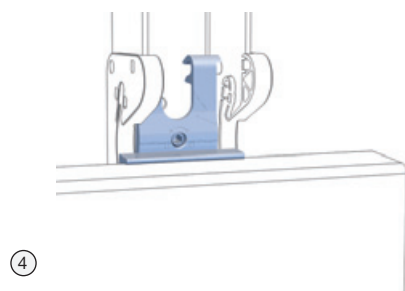
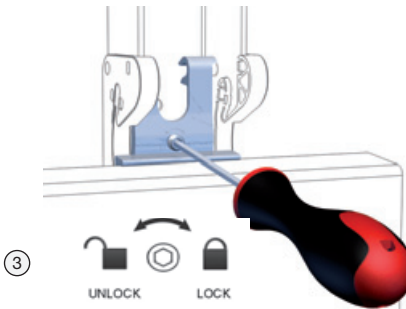
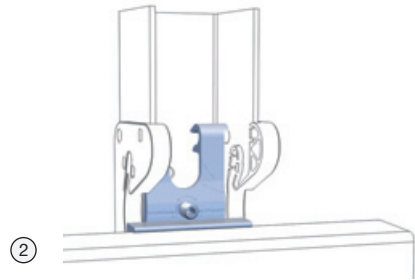
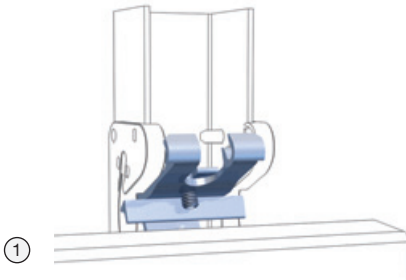
**Caution**

Take care not to overtighten the grub screw into the clamp.

6.5 Adjustment of panel position

After the FC panels have been installed and fixed points have been made, it is possible to re-adjust the position of the panels as shown below.

1. Horizontal misalignment of lower panel.
2. Wedge upper panel either side of fixed point with 4 mm shims.

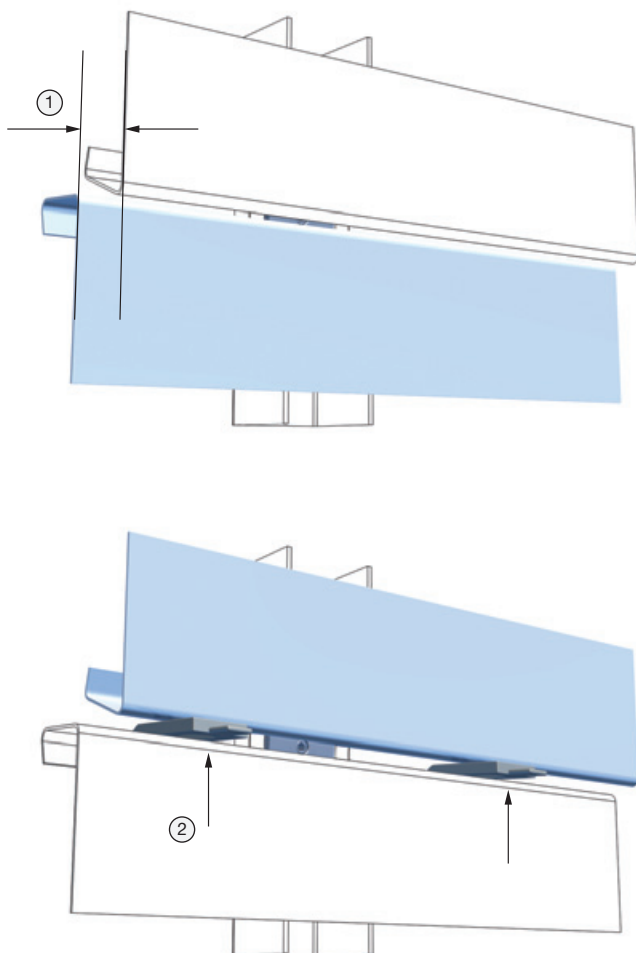

3. Unlock fixed point clamp with
Ø 3 mm Allen head screwdriver.

4. Align lower panel to correct position

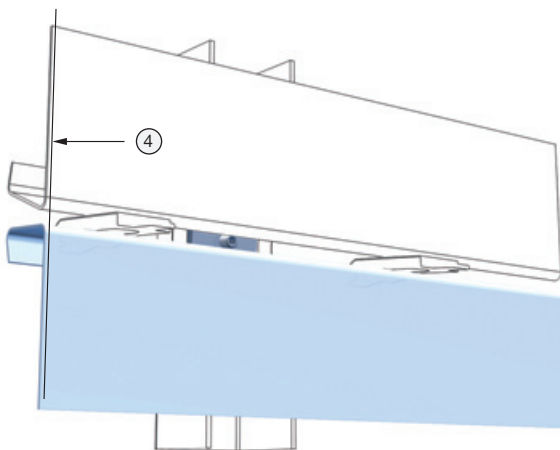
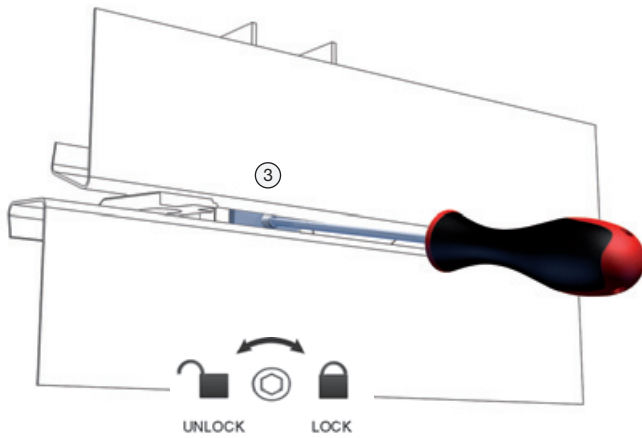

Adjustment of panel position

5. Relock fixed point clamp hand-tight

6. Remove wedges to return upper panel to original vertical position

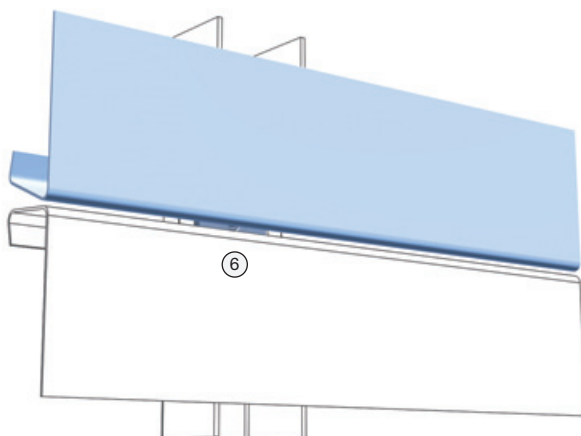
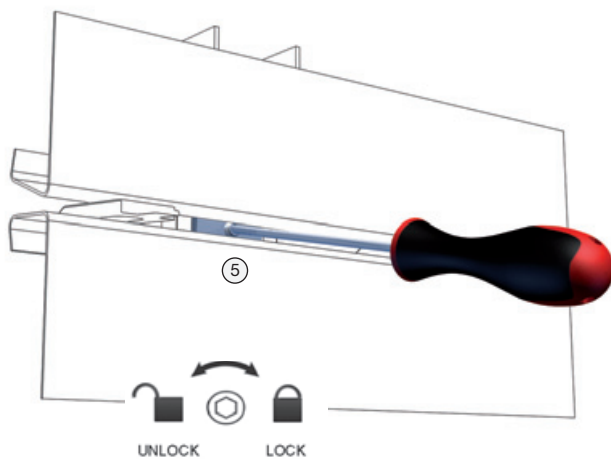

6.6 Corner panels

When no flashing is wanted at the corners, symmetric and non-symmetric internal and external corner FC panels can be supplied to order. This section gives details on the correct installation methods.

Panel supports

Special attention must be paid to the installation of corner panels. A modular click rail or mono-click bracket must be positioned between 80 mm and 100 mm

from the panel corner (A). For corner panels with unequal length sides, the mono-click bracket or modular click rail should be positioned on the long side of the panel. At both ends of the panel, a modular click rail or mono-click bracket must also be positioned between 80 mm and 100 mm from the panel edges (B) whether the sides of the panel are unequal or not. See drawing on page 60.

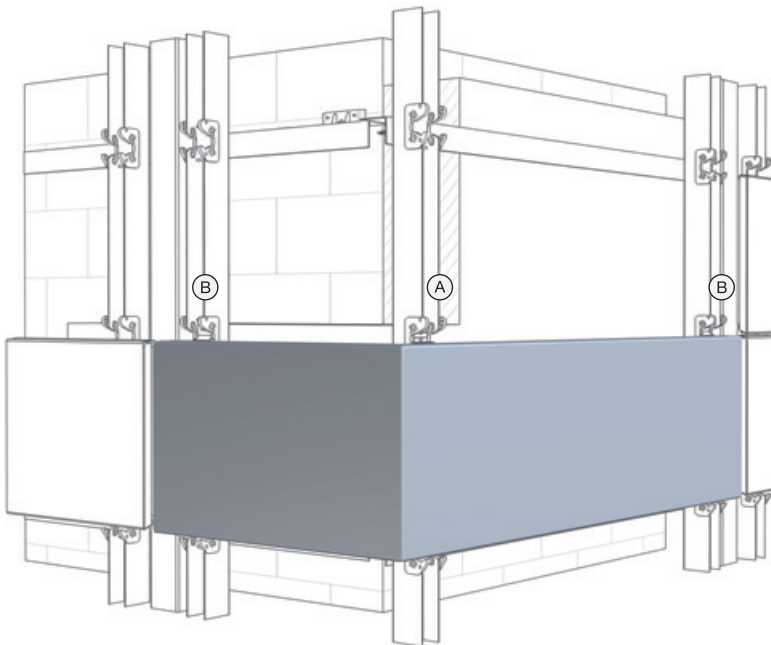

Corner panel fixed point

A fixed point must be installed at the mono-click bracket or modular click rail located at the corner of the panel.

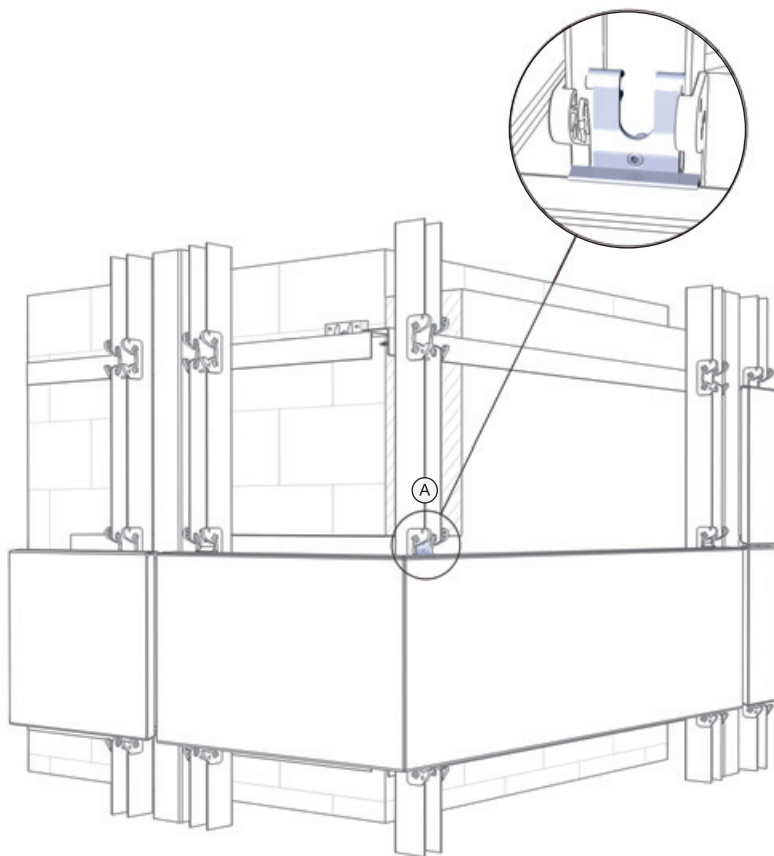

Corner panel guidance snapper

Guidance snappers should be fitted on the mono-click brackets or modular click rails at both ends of the panel. This is to ensure that the panels are

properly supported on both sides and sit straight in position. The guidance snapper is simply clipped over the pins at the top of the plastic insert.

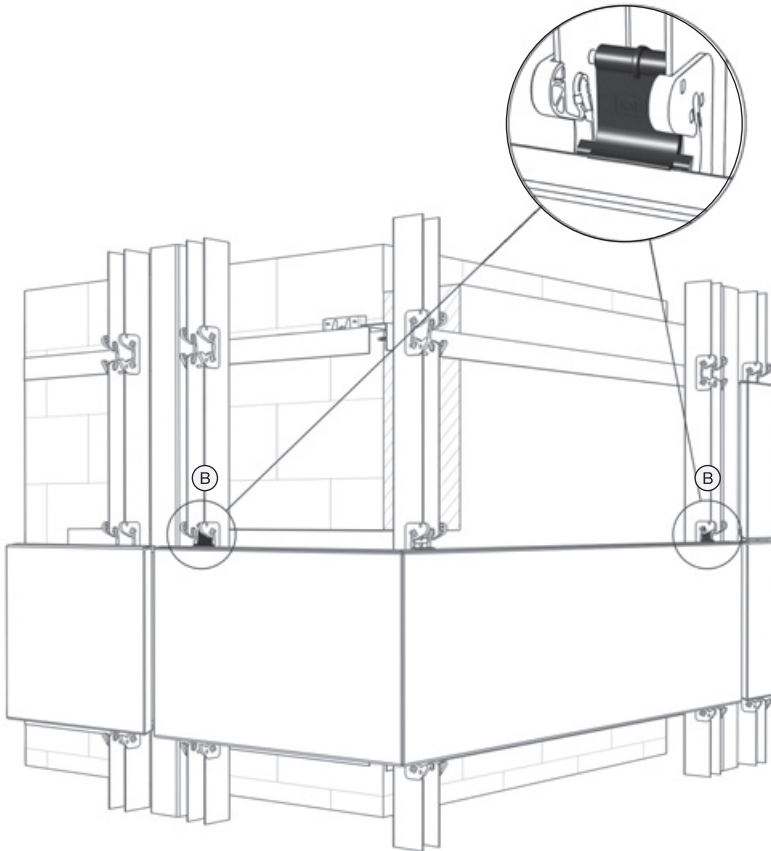

Corner panels (plan view)

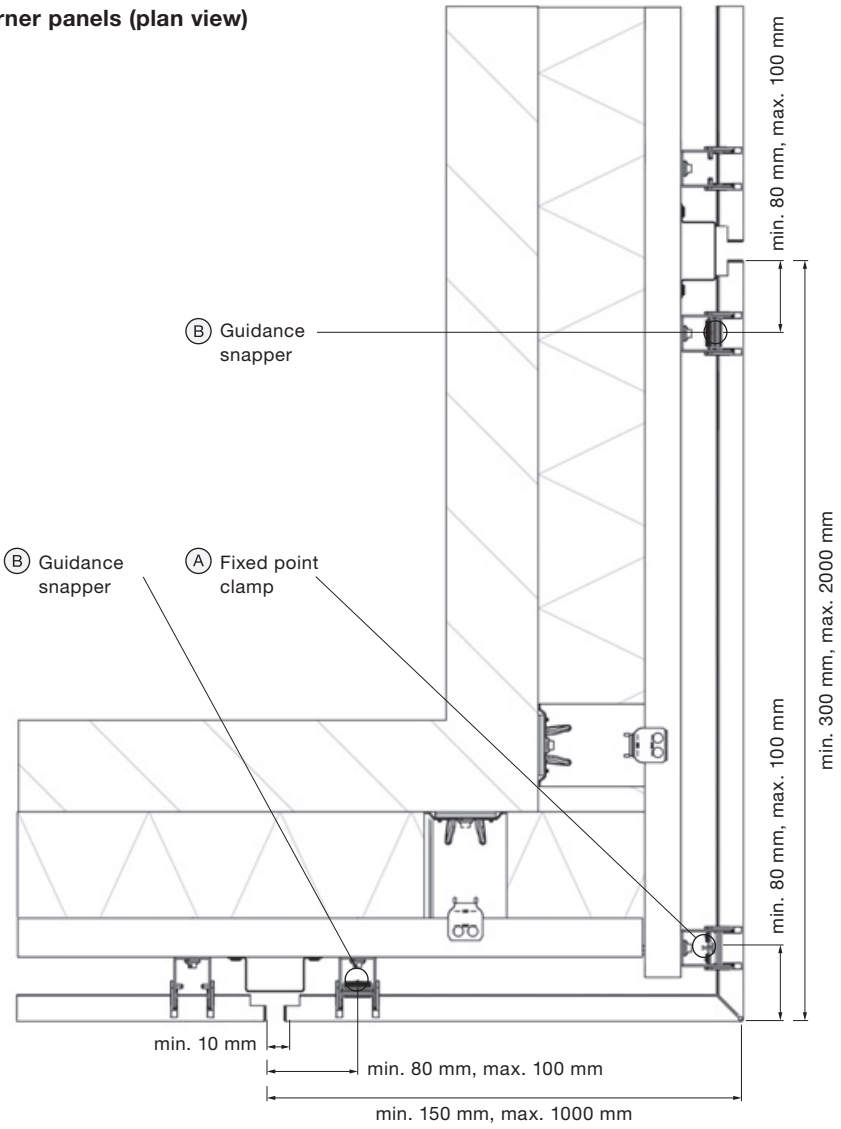

7.0 Flashing installation

Fixing flashings between panels is made fast and easy using the proprietary flashing support accessory. This component clicks into pre-punched holes in the modular click rails without the need for any additional fixings and provides a flat self-aligned surface to which flashings can be screwed or riveted.

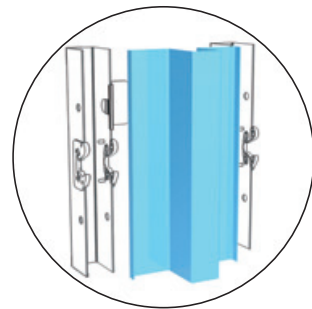
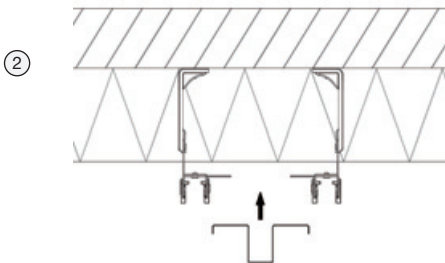
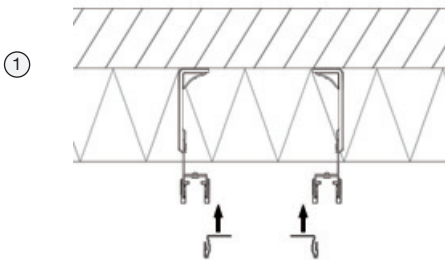
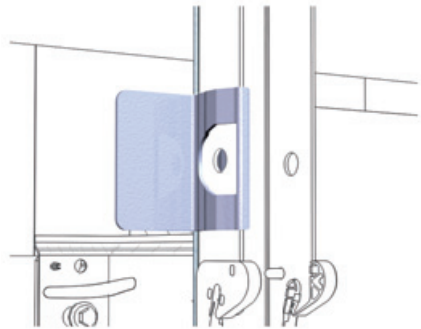

③

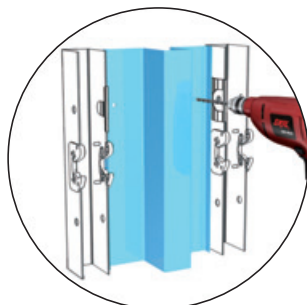
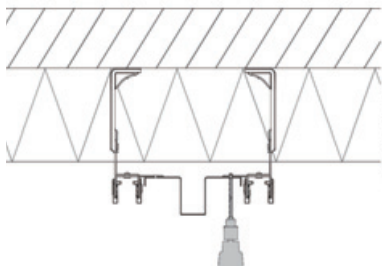

④

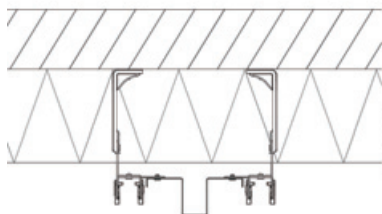

⑤

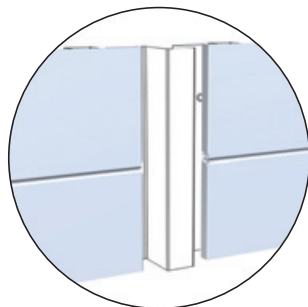
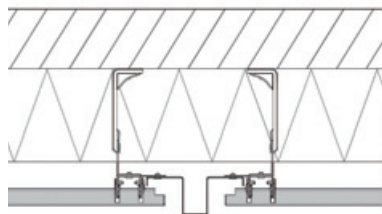

8.0 Individual panel replacement

In the event of wall damage, the FC façade locking geometry allows individual panels to be replaced without the need to demount the complete façade.

Individual panels can be removed quickly and easily using the specially developed panel removal tool available in the Kalzip FC Toolkit.



For the handling and removal of panels it is always necessary to wear adequate protective clothing, in particular safety shoes and protective gloves.

When using tools and machines to cut panels you should also wear ear protection, safety goggles and flame resistant clothing.

Operation and safety instructions of the tool or machine manufacturer should be followed at all times.

Individual panel replacement

1. Widen the horizontal panel joint by inserting the red 4mm wedges either side of the fixed point in the gap between the two panels and pushing them in as far as they will go.

Unlock the fixed point clamp using the Allen key and slide the panel to one side, widening the vertical joint to create space for the panel removal tool. Remove the wedges.

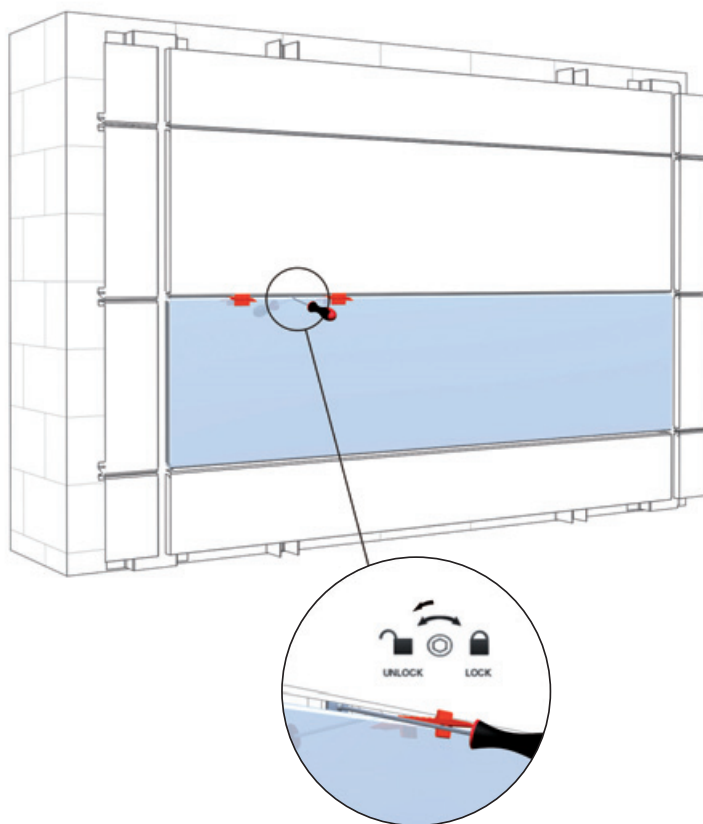

2. Insert the panel removal tool into the vertical joint at the bottom edge of the panel to be removed and rotate it into the horizontal joint. Slide along to the horizontal joint. Slide along to the first unclicking position.

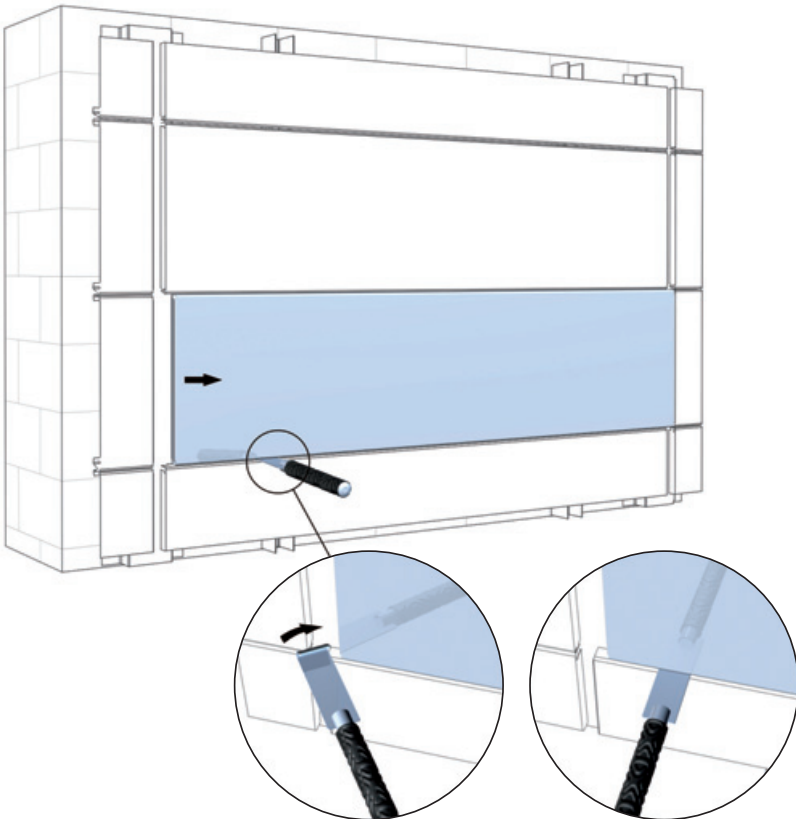

Individual panel replacement

3. Use the panel removal tool to release the lower panel edge out of the hooks.

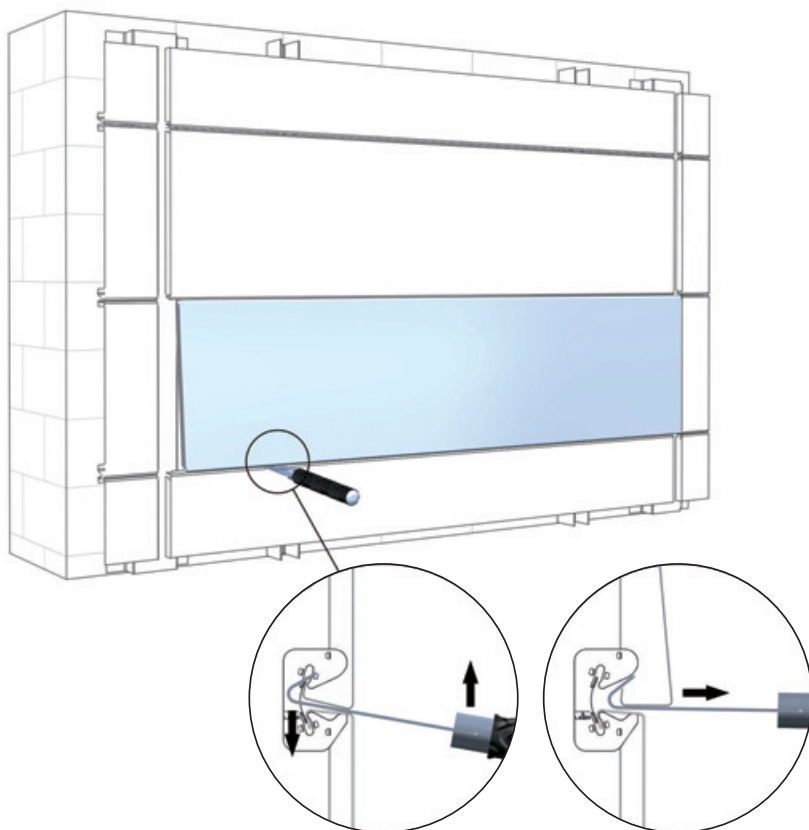

- Slide the panel removal tool along to the next unclocking position and repeat step 3 until the bottom edge of the panel is completely free from the supports.
- Repeat steps 1 to 4 for the panel above the panel to be replaced.

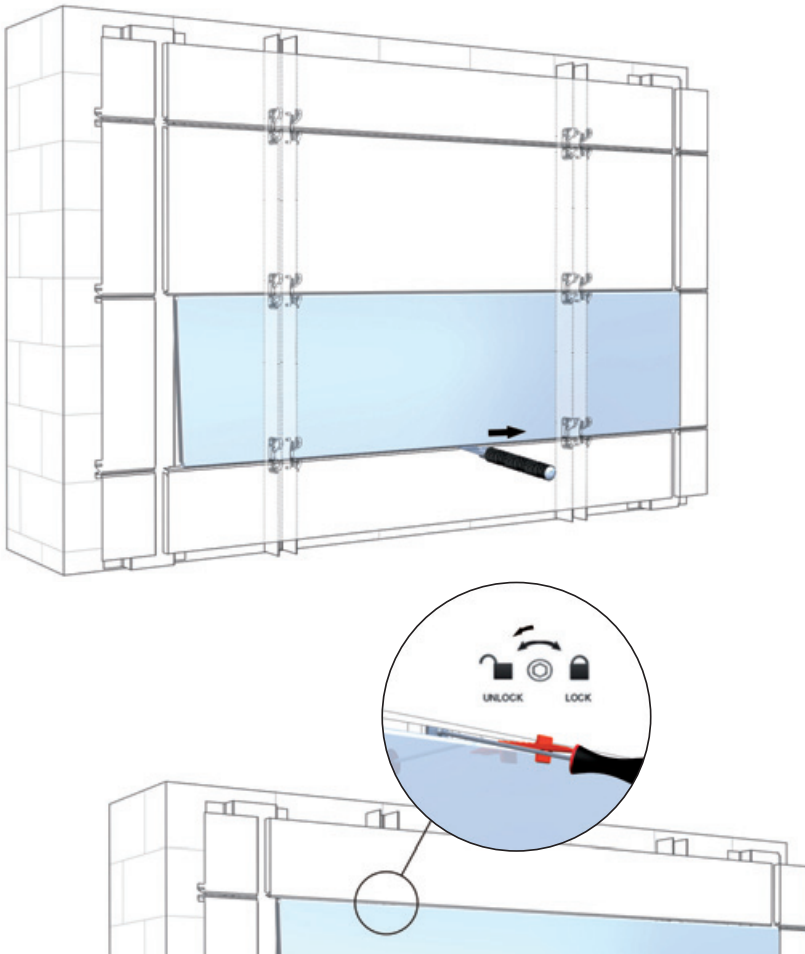

Individual panel replacement

6. Remove the fixed point clamp and guidance snapper(s) from the panel to be removed so that the panel can

be removed. Realign the top panel and relock the fixed pint clamp.

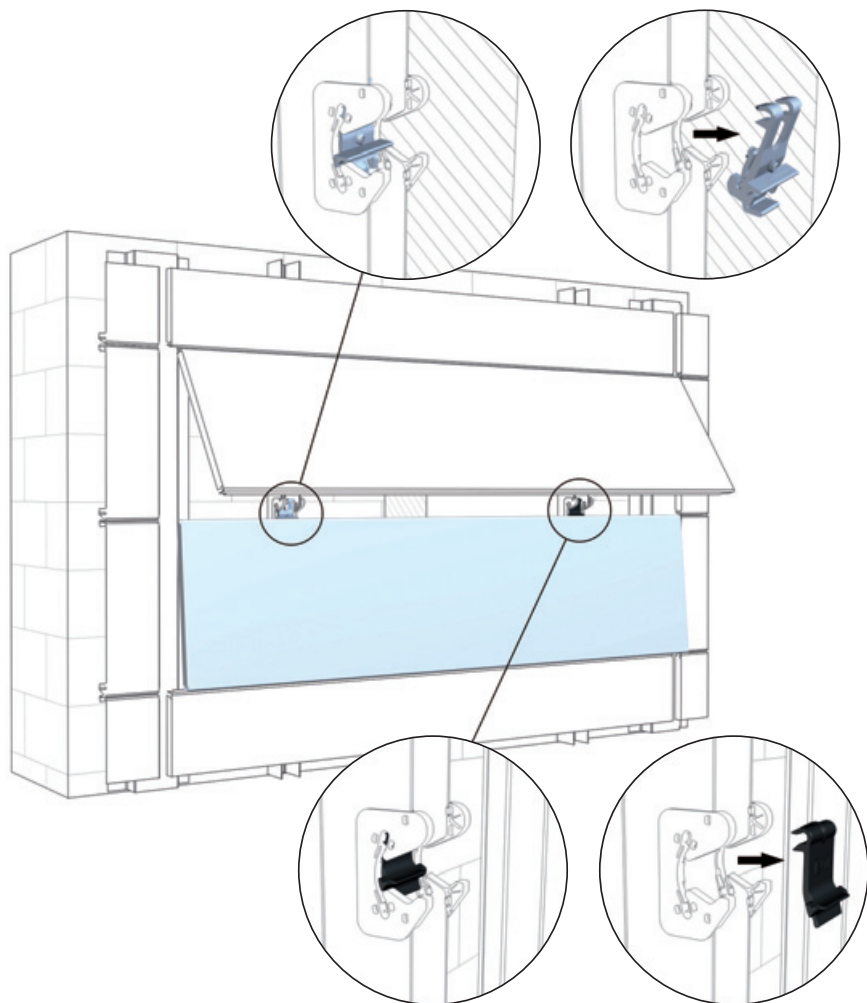

7. For safety under wind loading, a replacement panel should always be installed.

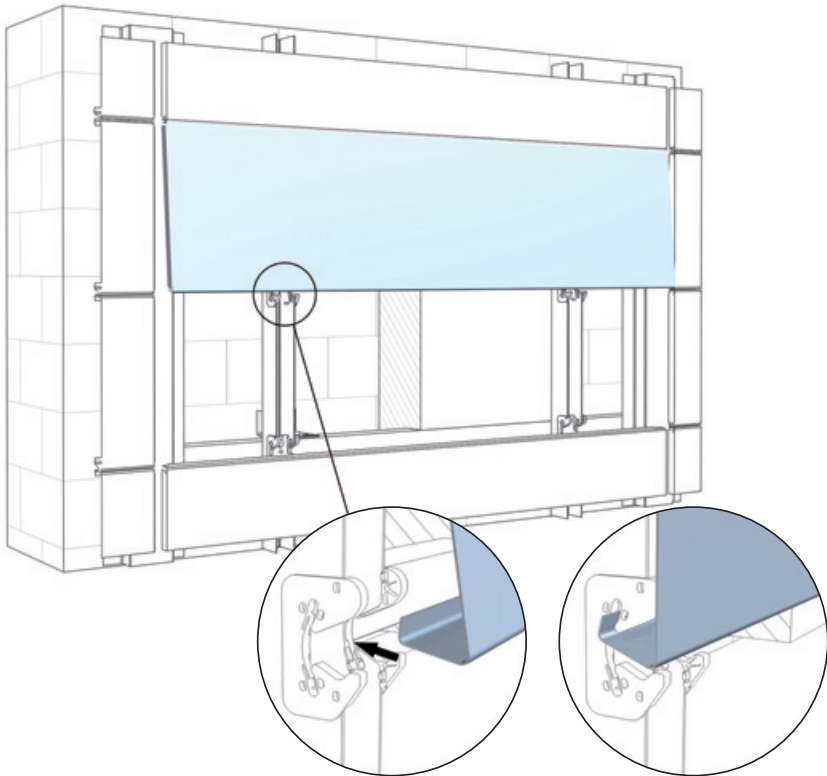



www.kalzip.com

The product and technical information contained in this document is accurate according to our knowledge at the time of publication. Details do not refer to any specific application and cannot give rise to any claim for compensation. From time to time our product range may alter as a result of our continued commitment to product innovation and development. Kalzip cannot guarantee that printed literature will contain the most recent updates; the latest editions are available to download at www.kalzip.com.

Copyright 2011

Kalzip GmbH
Part of Tata Steel Europe Ltd.

Kalzip GmbH
Kalzip GmbH
August-Horch-Str. 20-22 · D-56070 Koblenz
P.O. Box 100316 · D-56033 Koblenz
T +49 (0) 261 - 98 34-0
F +49 (0) 261 - 98 34-100
E germany@kalzip.com

English

The address of your nearest local sales office
can be found on our website: www.kalzip.com