



Kalzip® FC rainscreen system



Contents

Page



FC rainscreen system – simple, flexible and economical

Product and system characteristics	4
Features and benefits	5
System options and components	6
System accessories	9

The system in detail

Sub-constructions	12
Designing with the FC rainscreen system	14
Bi-directional panel installation	15
Panel removal	16
Summary of system benefits	17
Kalzip FC rainscreen system International projects	18



FC rainscreen - simple, flexible and economical



Product and system characteristics

New build and refurbishment

Kalzip FC rainscreen is a non-penetrative façade system that incorporates a fast-to-install lightweight flat rainscreen panel, suitable for both new build and refurbishment projects.

The main feature of the system is its flexibility which allows the installation of the profiles to be carried out in two directions, either from the top down or from the bottom up.

The choice of panel mounting direction one of the unique benefits which enables not only easier and faster installation compared to conventional panel systems but also allows scaffolding or subsequent construction work to be coordinated independently from the installation process. The system's innovative design and technical capabilities also allow individual panels to be removed and

installed without compromising the adjoining panels or the overall integrity of the façade system.

The Battenberg comprehensive school before (left) and after (right) renovation
Battenberg (D)

before



after



Features and benefits

- Contemporary, visually stunning aesthetics
- Several different standard profile widths provide flexibility and scope for design
- Highly cost-effective through simple and fast installation techniques
- Total flexibility with installation sequence
- Panels are supported by the proprietary modular click rail or mono-click bracket without the need for screws or rivets.
- Planning information and a range of CAD details are available for standard wall build-ups and sub-constructions.
- Optimised panel geometry means low inherent weight and reduced use of materials
- Variable acoustic and thermal insulation options
- A wide range of colour and surface finishes with edge folding as standard
- Fully integrated internal and external corner panels (optional)
- High structural performance
- Creation of fixed point with a specially designed fixed point clamp, which allows panel adjustment after installation.



System options and components

Panel widths

Profile type:	Kalzip FC 30/250	Kalzip FC 30/300	Kalzip FC 30/350	Kalzip FC 30/400	Kalzip FC 30/450	Kalzip FC 30/500
Profile thickness	1.0 mm 1.2 mm	1.0 mm 1.2 mm	1.0 mm 1.2 mm	1.0 mm 1.2 mm	– 1.2 mm	– 1.2 mm
Micro-ribbed	no	no	no	yes	no	no

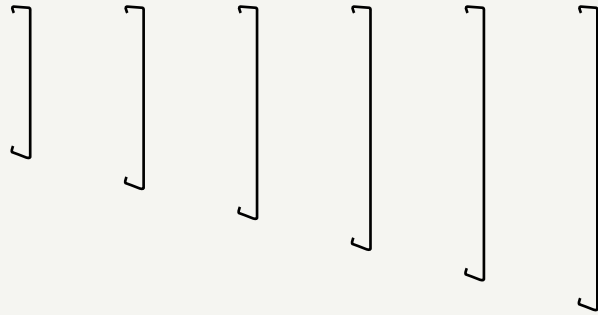

Profile example

Kalzip FC with edge return (supplied as standard)



Kalzip FC without edge return (on application)



Transition panels

For profile type:	Kalzip FC 30/250	Kalzip FC 30/300	Kalzip FC 30/350	Kalzip FC 30/400	Kalzip FC 30/450	Kalzip FC 30/500
Front face dimension	280 mm	330 mm	380 mm	430 mm	480 mm	530 mm

Transition panels, upper fold (left) lower fold (right)



Corner panels

Corner panels can be manufactured as internal and external corners with different angles.

Specification

Leg 1: min. 150 mm/max. 1.000 mm
Leg 2: min. 300 mm/max. 2.000 mm

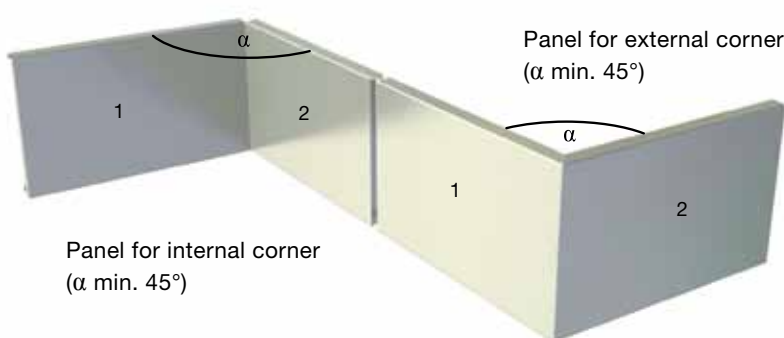

Edge return

FC panels are supplied as standard with edge returns on both sides without surcharge.

Panels can also be manufactured without edge return on enquiry.

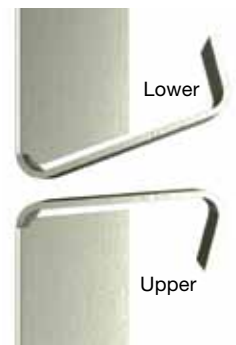

17 mm
edge return dimensions



Perforated panels

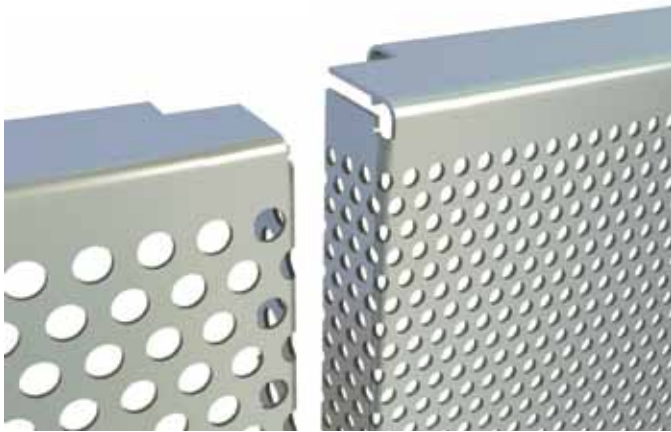

RV 6-8

Hole pattern:
min. 45 % / max. 48 %
depending on panel width
Hole diameter: 6 mm

RV 3-5

Hole pattern:
min. 29 % / max. 31 %
depending on panel width
Hole diameter: 3 mm

Micro-ribbed panel

Kalzip FC 30/400 with edge
return and micro-rib

Start of micro-rib:
20 mm from the end of the
panel

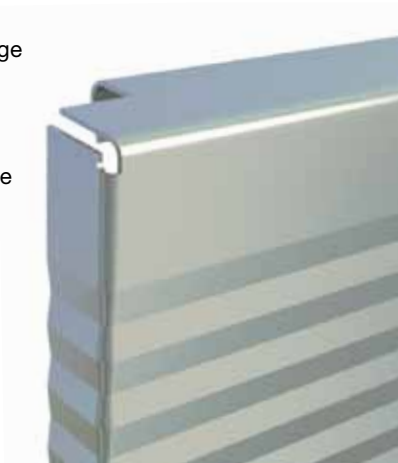

Technical data

Surfaces

- Four standard colours, others are available on application for material thickness 1.0 mm and 1.2 mm
- Available in polyester and pvdf finishes
- Further RAL, NCS and special colours are available on application

Note: all surfaces are delivered as standard with a protective film.

Materials

EN AW-3004, EN AW-3005 or EN AW-6025

Dimensions

Length: min. 400 mm / max. 6,000 mm
other profile lengths available on request

Load-bearing capacity values

Load-bearing capacity values are based on Eurocode 9 and DIN 18807 in accordance with building authority approval no. Z-14.1-581 issued by the German Institute of Building Technology

Tolerances

Sheet length according to Kalzip works standard

L 0.4 – 4.00 m	+2/-2 mm*
L > 4.00 – 8.00 m	+3/-3 mm*

System options and components

NE modular click rail (non-load bearing)

The NE modular click rail is a non-load-bearing rail and must be fixed at every joint position. The geometry corresponds to the mono-click bracket.

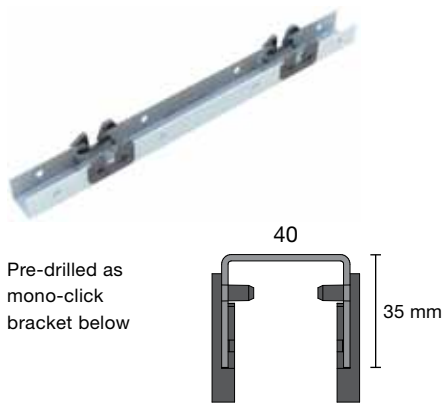

SE modular click rail (load bearing)

The SE modular click rail is a self-supporting rail that can be used as load-bearing profile and can be fastened to a sub-construction independent of the joint position.

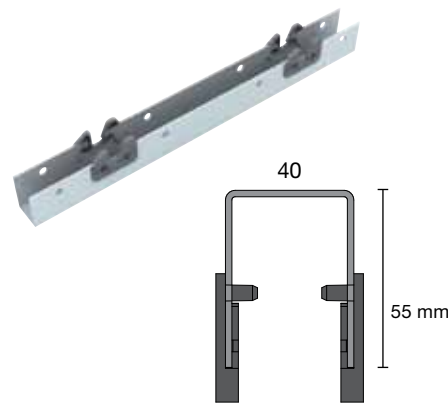

SEL modular click rail (load bearing)

The SEL modular click rail is also a load-bearing rail and can be fastened directly to L wall holders thanks to the 50 mm long web. A further support profile is not necessary.

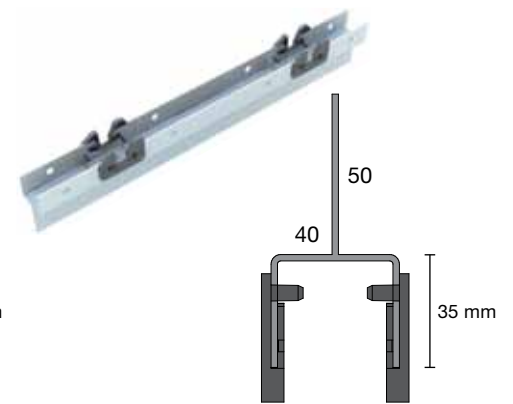

Standard lengths

Modular click rails (NE, SE, SEL)

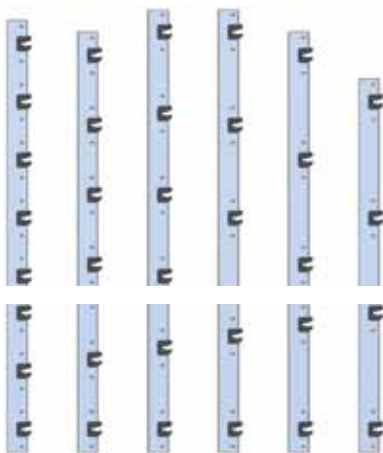

Type	250	300	350	400	450	500
Length in mm	2.950	2.900	3.000	3.000	2.900	2.700
Number of hook-in points	12	10	9	8	7	6

Mono-click bracket

The mono-click bracket is used in particular for rainscreen areas with changing panel widths or with complex connection details. It must always be fastened with two screws or rivets.

Plastic Inlay

The plastic inlays are provided with a laser line, which ensures the simple and accurate placement of the modular click rails.

Mono-click bracket with plastic inlay
 Length: 75 mm
 Drilled hole:
 central distance: 50 mm
 hole diameter: 5.2 mm

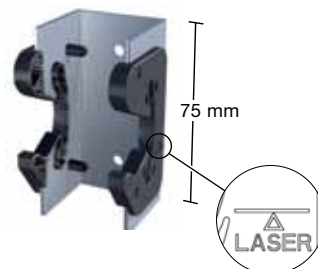

Setting out tool

With the aid of the setting out tool, modular click rails mounted above one another, can be adjusted to fit the installation width of the FC panels with no additional measurement. The tool can be easily adjusted to the panel dimension.



System accessories

Fixed point clamp

In order to guarantee a uniform vertical joint, each FC panel must be fixed in position by a fixed point clamp. After the installation and alignment of the panel, the fixed point clamp can be loosened and fixed again, if necessary through the horizontal panel joint.

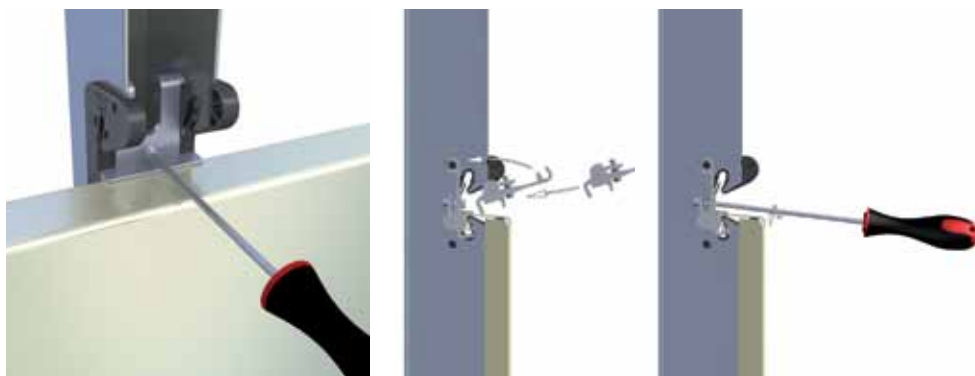

Guidance snapper

The guidance snappers ensure a constant gap between the panels and guarantee a uniform joint. Use of the guidance snapper is necessary for short panels and corner panels. Further information can be found in the installation manual.



Flashing support

The flashing support is snapped into the modular rail, for simple and quick installation of flashings.

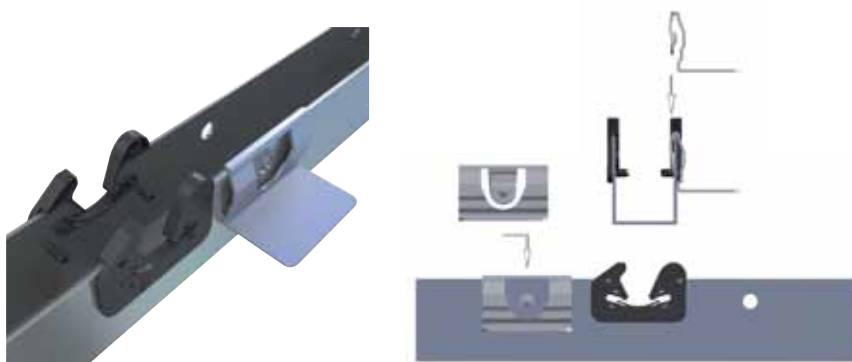

Number and arrangement when fastening vertical joint strips: approx 1.5-off per m (offset arrangement)

The system in detail

Kalzip FC rainscreen system



Panels

Delivery options

- 1 FC panel
- 2 FC corner panel
- 3 Micro-rib surface (FC 30/400 only)
- 4 Perforation Rv 3-5
- 5 Perforation Rv 6-8
- 6 FC panel luminaire

System sub-construction

Variants

- 7 Mono click bracket
- 8 SEL modular click rail
- 9 NE modular click rail
- 10 SE modular click rail

System accessories

Parts and components

- 11 Fixed point clamp
- 12 Guidance snapper
- 13 Flashing support
- 14 Plastic inlays
- 15 Setting out tool
- 16 Panel removal tool
- 17 Plastic wedges



System depth with mono-click bracket, NE and SEL modular click rail



System depth with SE modular click rail

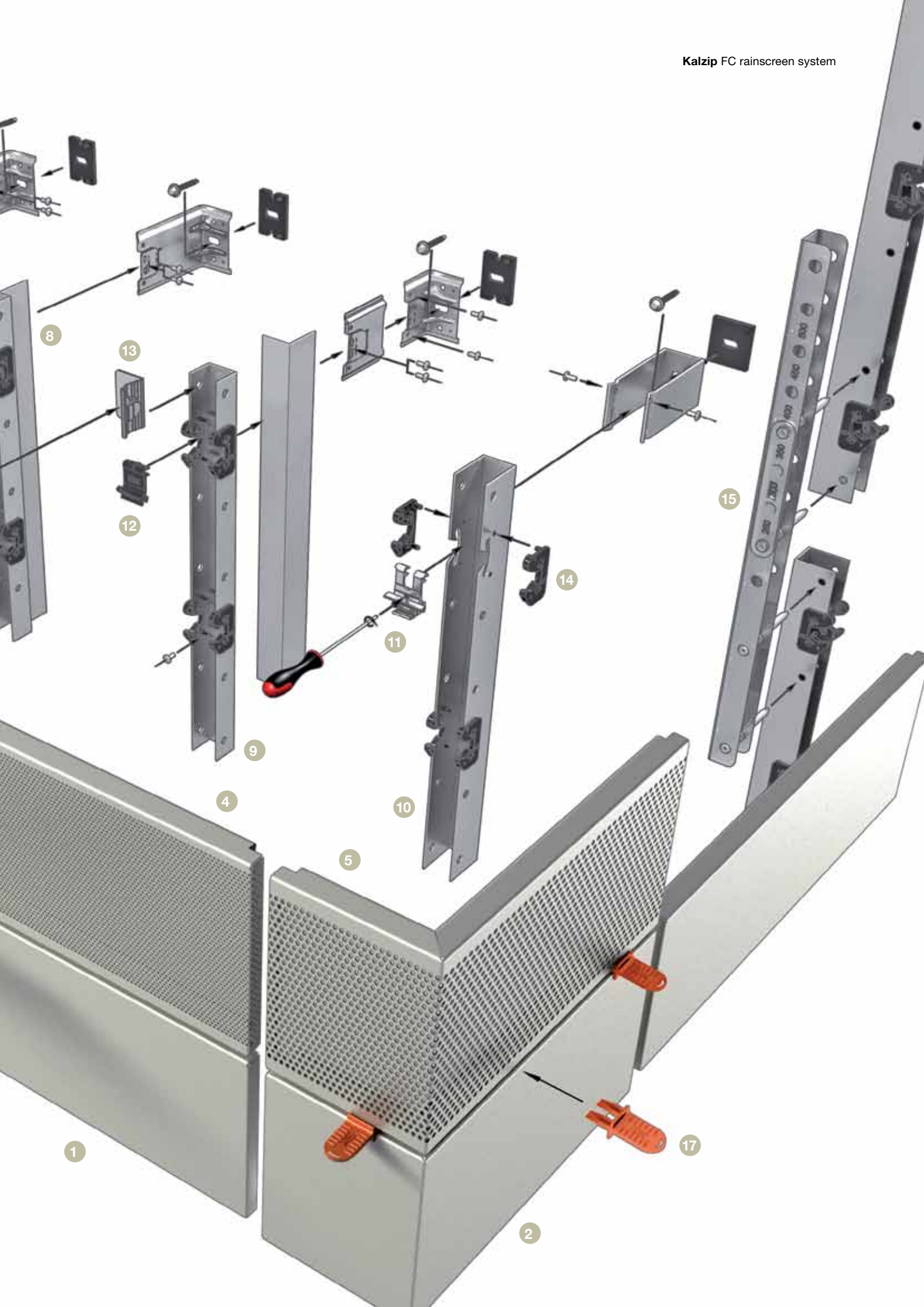



Sub-constructions

① Mono-click bracket on vertical sub-construction

This version offers high flexibility for variable installation widths and in particular in joint areas (e.g. windows, openings, upper and lower junctions and terminations). The vertical L-rail is fastened with brackets to the support structure. The rail can be supplied pre-punched in a system pattern.



② NE modular click rail on a vertical sub-construction

The NE modular click rail is fastened to vertical support profiles. Alignment takes place in two steps with this system. A flat plane is created with the support profile; the modular rail then only needs to be adjusted in height. This guarantees correct alignment of the system.



③ SEL modular click rail on individual wall brackets

The SEL modular click rail is a combination of support rail and modular rail. In conjunction with brackets, it can be used directly as a complete sub-construction. Since this system consists of only two components, it is very economical in terms of both material usage and installation times.





④ SE modular click rail on U wall bracket

This system consists of a supporting modular click rail and U-profile wall brackets. Since this system consists of only two components, it is very economical in terms of both material usage and installation times. However, alignment and adjustment of the rail should be carried out by experienced fitters.



⑤ SE modular click rail on a horizontal sub-construction

The most suitable construction for use with typical SFS frame systems.



⑥ SE modular click rail on a structural cassette

The supporting SE modular click rail can also be used on steel cassettes / decks. The rails are spaced according to the load / span of the FC panels and on the other in accordance with the requirements for the steel cassettes / deck. The steel cassettes must be mounted flat. Shims will be required for line and level of the system.



Designing with the FC rainscreen system

Design variants



A Narrow flashing



B Wide flashing



C No flashing



D Overlapping flashing

Detail numbers

The FC rainscreen system can be used in principle with all existing support structures and wall constructions. 10 standard details in 4 different sub-construction variants have been developed for 6 different system solutions as examples.

These are available as pdf or dwg files in the literature section at www.kalzip.com.

Selection takes place according to the following procedure

1. Selection of the suitable sub-construction (p. 12/13)
2. Selection of the design variant
3. Selection of the required detail

Details

Number	Description
101	Vertical joint
102, 103	External corner 90°
104, 105	Internal corner 90°
106	Window cill

Number	Description
107	Door / window jamb
108	Door / window head
109	Cill
110	Parapet

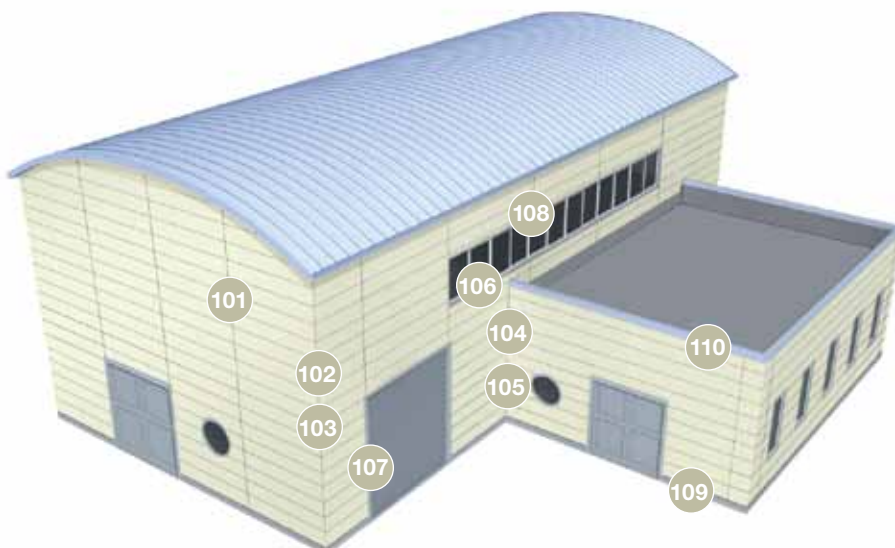

Bi-directional panel installation

Installation from bottom to top

- Step 1** Hook in panel
- Step 2** Click in panel
- Step 3** Click in fixed point clamp, adjust panel, tighten fixed point clamp.
- Step 4** Install next panel

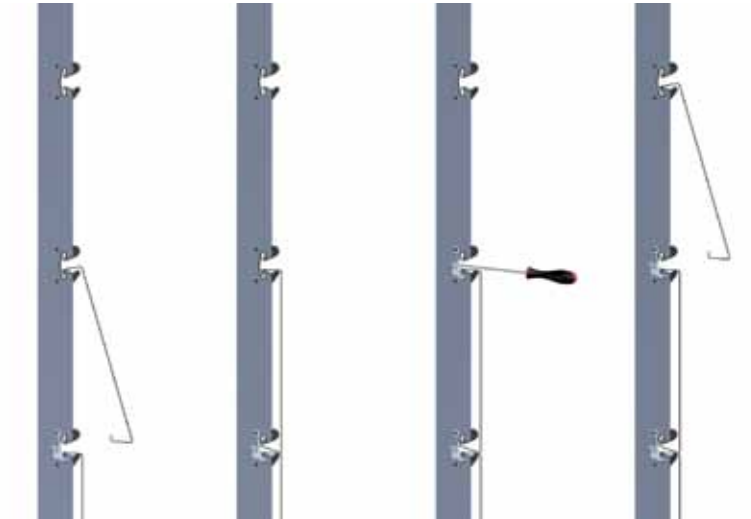

Installation from top to bottom

- Step 1** Hook in panels
- Step 2 and 3** The upper panel must be removed a little from the front in order to install the fixed point clamp. Click in fixed point clamps, adjust panels, tighten fixed point clamps
- Step 4** Click in panels

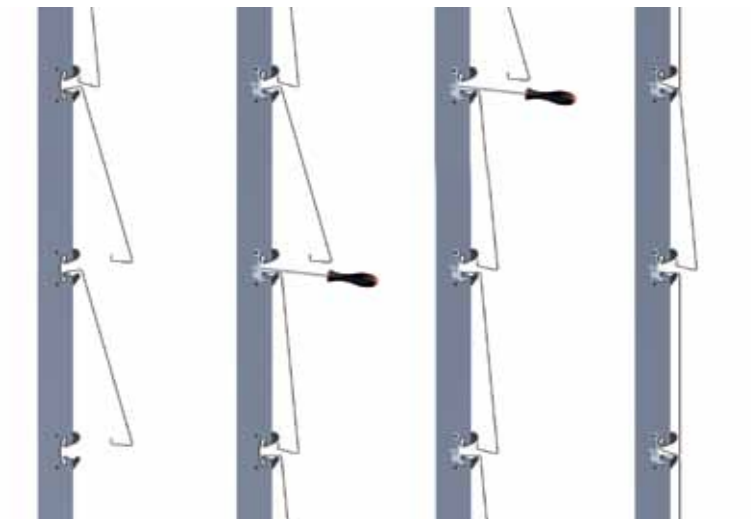

In the middle of the area

- Step 1** Unhook the panel above the panel to be installed.
- Step 2** Hook in panel
- Step 3** Click in fixed point clamp, adjust panel, tighten fixed point clamp.
- Step 4** Click in panel

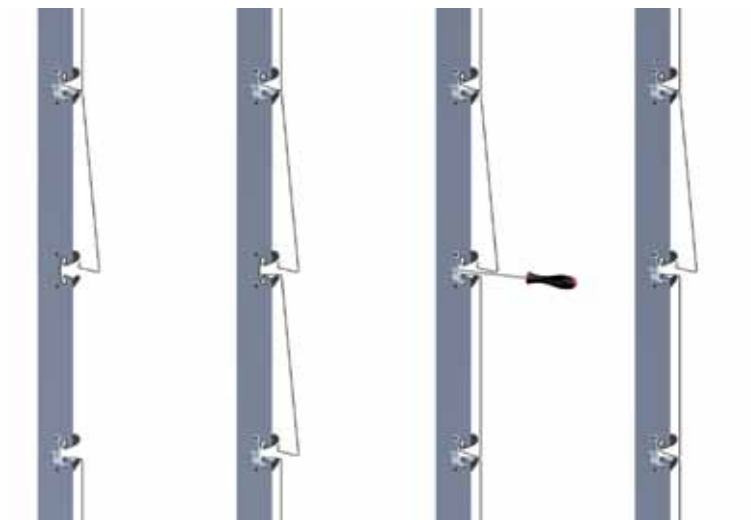

Panel removal

In case of damage, the FC rainscreen allows the replacement of individual panels without having to dismantle the entire façade. A panel can be removed quickly and simply using the specially

developed tools from the Kalzip FC tool kit. The panel removal tool is inserted into the joint, pushed up to the first modular rail and the panel is then levered out.

This process is repeated on each rail. More detailed information can be found in the FC installation manual.

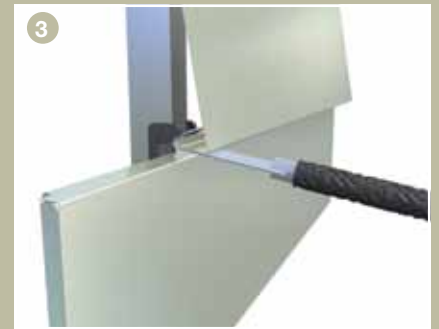

Summary of system benefits



1 Innovative click system

With the FC rainscreen system the alignment of the rainscreen takes place within the sub-construction. The rainscreen panels then only need to be hooked and clicked in, and their position secured with the fixed point clamp.

2 Variable installation

In areas where the FC panels cannot be installed directly due to scaffolding, missing panels or other reasons, these can be installed later with no additional expenditure. Building progress is not hindered and additional costs due to longer scaffolding times are avoided.

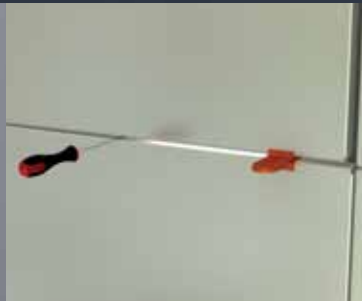

3 Easy to install

If the vertical joint pattern does not meet the requirements of the building owner or the architect after completion of the work, the panels can be subsequently adjusted (through the joint).

4 Flexible system

Different panel widths, special edged panels or special joint panels can be integrated into the system and require no separate sub-constructions or fasteners. This makes the FC rainscreen system particularly flexible for planners and contractors.



5 Simple to dismantle

A special feature is the option to remove and reinstall individual FC panels without damage and without having to dismantle the entire rainscreen area. This also allows elements to be integrated that have to be serviced from time to time.

Kalzip FC rainscreen system international projects

The following is a snapshot of the Kalzip FC rainscreen system from around the world. Visit our on-line gallery at www.kalzip.com to view further examples of inspiring metal architecture.



Rathfriland Fire Station, Northern Ireland



Rosen Technology and Research Centre, Germany



Spirit of Spice, Germany



Ski lift, Lenzerheide, Switzerland



VESPE, Germany



Rekord Fenster, Austria



Vocational School, Germany



Heinrich Meier GmbH Mühlacker, Germany



Lanxess Bitterfeld, Germany



Comprehensive School Battenberg, Germany



Louisiana Superdome, New Orleans, USA



Helmholtz-Institut, Germany



Einkaufszentrum, Germany

www.kalzip.com

While care has been taken to ensure that the information contained in this brochure is accurate, neither Tata Steel Europe Limited nor its subsidiaries accept responsibility or liability for errors or information which is found to be misleading.

Copyright 2013
Kalzip Ltd

Kalzip Ltd
Haydock Lane
Haydock
St Helens
Merseyside WA11 9TY
T: +44 (0) 1942 295500
F: +44 (0) 1942 295508
E: enquiries.uk@kalzip.com

English