

PRE-DELIVERY GUIDE 2014

How to make the delivery and installation of your new hot tub fast, easy, and trouble-free



Important Pre-Delivery Information

Please read this booklet before your scheduled delivery day.

Record your spa information below and then store this booklet in a place you can easily find it. If service is required, your dealer will ask for these details.

Spa Model _____
Spa Serial Number _____
Date Purchased _____
Date Installed _____
Spa Dealer's Name _____
Spa Dealer's Phone # _____
Spa Dealer's Address _____

Consult your local state or city building ordinances to ensure installation is in accordance with local codes. The spa's warranty becomes void if these guidelines are not followed.

Most cities and counties require permits for exterior construction and electrical circuits. In addition, some communities have codes requiring residential barriers such as fencing and/or self-closing gates on the property to prevent unsupervised access to a spa by children. Your Jacuzzi dealer can provide information on which permits may be required and how to obtain them prior to delivery of your spa.

The specifications published in the Spa Dimensions and Specifications section of this book are approximate. Always measure your spa before making critical design or delivery decisions.

Congratulations!

You've purchased a Jacuzzi® hot tub. With a little preparation and care, your spa will give you many years of enjoyment. This booklet has been designed to provide you with all of the information you'll need to ensure a safe, speedy, and trouble-free spa delivery and installation.

Table of Contents

Planning the Best Location for Your Spa	3
Suggestions for Outdoor Spa Installation	3
Suggestions for Indoor Spa Installation.....	7
Planning to Move the Spa Into Your Yard	8
Equipment Access Consideration for the J-LXL® and J-LX® Models	10
Electrical Tasks Before Spa Delivery	11
General Electrical System Considerations	11
Power Configurations for Models J-495 (North America, 60Hz).....	13
Power Configurations for Models J-425, J-465, J-470, J-480 (North America, 60Hz)	14
Power Configurations for Models J-415 (North America, 60Hz).....	15
Power Configurations for Models J-LX® and J-LXL® (North America, 60Hz)..	16
Power Configurations for Models J-335, J-345, J-355, J-365, J-375, J-385 (North America, 60Hz)	17
Power Configurations for Models J-235, J-245, J-275, J-280 (North America, 60Hz)	18
Power Configurations for Models J-210, J-315, J-325 (North America, 60Hz)	19
Electrical Tasks After Spa Delivery	20
Installing a 3-Wire 240 VAC Connection for Models J-415, J-425, J-465, J-470, J-480 and J-495.....	20
Installing a 3-Wire 240 VAC Connection for Models J-LX® and J-LXL®.....	22
Installing a 3-Wire 240 VAC Connection for Models J-235, J-245, J-275, J-280, J-335, J-345, J-355, J-365, J-375, J-385.....	24
Installing a 3-Wire 120 VAC or 4-Wire 120/240 VAC Connection for Models J-210, J-315, J-325.....	26
Final Electrical Connections	28
Connection Configuration #1 240 VAC Connections for Models J-415, J-425, J-465, J-470, J-480, J-495 (North America 60Hz)	29
Connection Configuration #2 240 VAC Connections for Models J-235, J-245, J-275, J-280, J-335, J-345, J-355, J-365, J-375, J-385, J-LX®, J-LXL® (North America 60Hz)	30
Connection Configuration #3 120 VAC Connections for Models J-210, J-315, J-325 (North America 60Hz).....	31
Connection Configuration #4 240 VAC Connections for Models J-210, J-315, J-325 (North America 60Hz).....	32

Spa Dimensions and Specifications..... 33
 Useful Details About the Spa 33

Water Capacity and Average Fill Volume 34

Planning the Best Location for Your Spa

Now that you have purchased your hot tub, you need to decide where to install it. Do you want to install it outside or inside? There are many factors to take into consideration when making these location decisions. Answering the questions in this section can help you make the right choices.

Suggestions for Outdoor Spa Installation

Where should I install the spa?

When deciding where to place your spa, it should be:

- Because of the risk of severe injury from electric shock or death from electrocution. Moved away from overhead power lines. A minimum of 10 feet (3 meters) is suggested. See additional safety instructions listed in the owners manual.
- Placed to face a view you enjoy. Do you have a special landscaped area in your yard that you find pleasant?
- Located in an area that gives you the best privacy options. Think of the spa's surroundings during all seasons when making your choice. During cold, winter weather, bare trees won't provide much privacy.
- Locate your spa in a sheltered location to protect yourself from the wind and harsh weather while bathing in your spa. This reduces the cost of spa operation and maintenance.
- Consider locating your spa away from any reflective surface or glass. The heat deflected from such a surface may cause damage to the synthetic cabinet panels.

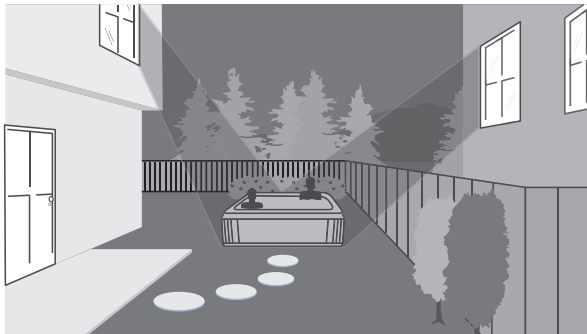

Figure 1 Plan for privacy before the spa is delivered

What kind of foundation is available?

- Because of the combined weight of the spa, water, and bathers, it is extremely important that the base upon which the spa rests can uniformly support this weight without shifting or settling for the entire time the spa is in place. The base should be smooth, flat, and level.

Which is best?

- We suggest the following pads:

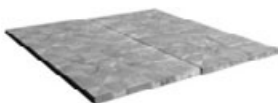

Good

Synthetic spa pads can be purchased from your Jacuzzi dealer. These pads can be placed on a smooth, flat, and level surface.

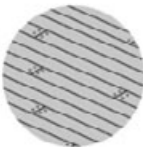

Better

Wood decking with a concrete foundation.



Recommended

Concrete pad (4 in. [10 cm] or thicker). We recommend a poured, reinforced concrete slab with a minimum thickness of 4 in. (10 cm).

- **CAUTION:** When you install the foundation, be sure that water drains away from it. Placing the spa in a depression without provisions for proper drainage could cause rain or any water overflow to flood the equipment and create a wet condition in which the spa would sit.
- **CAUTION:** For spas that are to rest on balconies, roofs or other platforms not specifically tied into the main structural support, you should consult a professional Structural Engineer with experience in this type of application.
- **CAUTION:** If the spa is placed on a surface which does not meet these requirements, damage to the cabinet and/or the spa shell may result. Damage caused by an improper foundation is not covered under warranty. It is your responsibility to assure the integrity of the support at all times. Do not shim the spa. For proper support, the spa must sit flat on the intended foundation.
- **⚠ WARNING:** Proper ventilation should be discussed with an Engineer or authority competent enough to understand the necessary provisions needed to vent moist or heated air and air associated with chemical odors outdoors. When the spa is in use considerable amounts of moisture will escape potentially causing mold and mildew, over time this can damage certain surfaces and or surroundings.

Planning the Best Location for Your Spa, *Continued*

How will I use the spa?

Consider how you intend to use your spa.

If using the spa for ...	Then ...
Family recreation	Leave plenty of room around the spa for activities and yard furniture.
Relaxation and therapy	Create a quiet and relaxing environment around the spa.

Does the climate I live in make any difference to where I install my spa?

When deciding the best place to install the spa, consider

If your climate is ...	Then consider installing ...
Cold and snowy in winter and warm in summer	The spa close to the back door or near the pool house for fast access to a warm room
Warm in winter and hot in summer	A patio cover or perhaps a gazebo to provide shade

What about spa servicing?

At some time, a service technician may need to access the spa's equipment bay or plumbing components by removing one or all of the side cabinet panels.

To make access easy, create an installation plan that includes the details for removing the side cabinet panels to easily reach the spa's equipment bay and control panel. Depending upon your type of installation, keep in mind that the spa might sometime need to be moved or lifted from the ground. Make sure you provide access to the CLEARRAY® Water Purification System behind the front cabinet panel for yearly bulb replacement.

What other issues should I consider?

When selecting the ideal outdoor location for your spa, consider these suggestions:

- Keep the pathway to your spa free of debris to prevent dirt and leaves from being tracked into the spa.
- Prevent leaves and bits of plants from dropping in the spa by keeping trees and shrubbery away from the spa.
- For J-400 Models: We recommend installing the front of your spa facing a window on your home with the Status Indicator in a direct line-of-sight. This orientation allows you to visually check the Status Indicator in all weather conditions from the comfort of your home. The indicator glows white when all systems are normal, turns red if an error condition exists, or turns off when the spa has no power.



What other issues should I consider?

For J-400 Models: We recommend installing the spa permit easy access to the quick-drain port located on the side skirt panel. An included drain hose assembly attaches to this port to provide rapid water removal during scheduled water changes. When draining your spa, always route drain water away from the spa and the foundation of your house into a area capable of absorbing large amounts of water without causing damage to your property. Remember, your spa holds several hundred gallons of water. For this reason, we recommend choosing a location that drains directly to the street curb whenever possible.

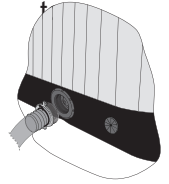

Suggestions for Indoor Spa Installation

If you are installing your spa indoors, take into consideration your answers to the questions below.

What are the issues I need to think about when installing a spa indoors?

When installing a spa indoors, it is extremely important to build into your plan a method of handling any excess water. Consider:

- How should water spills be handled?
- How many drains should be installed?
- What is the best flooring to install near the spa?
- If a leak occurs, can the floor handle the entire contents of the spa?
- Will the furniture and walls around my spa withstand and resist water and moisture?
- What provisions should I make for the ceiling and structures that may be below the spa.

What do I need to know about installing a spa on the second floor.

If the spa is being installed on a second story or higher, consult a structural engineer to discuss the best way to support the spa. Special attention is needed to plan for a spa installed on a balcony or roof.

What about spa servicing?

Most spa servicing is performed on the spa equipment that is located behind the side cabinet panels of the spa. It is important to install the spa to allow easy access to the spa equipment. Make sure you provide access to the CLEARRAY® Water Purification System behind the front cabinet panel for yearly bulb replacement.

How can I ventilate the spa area?

When the spa is in use, considerable amounts of moisture/water are present. **Over time, this moisture may cause mold and mildew and damage to certain surfaces and/or surroundings. Proper ventilation should be discussed with an engineer who understands the necessity of venting moist and heated air that is associated with chemical emissions.**

What warranty considerations are important?

Consult your local state or city building ordinances to ensure installation is in accordance with local codes. Any damage caused if you do not follow these guidelines voids the spa's warranty.

Planning to Move the Spa Into Your Yard

Use the information below, in Figure 2, and in the Spa Dimensions and Specifications chart to plan the delivery of your spa into your yard. The Spa Dimensions and Specifications chart lists your spa model and its dimensions.

- Check your spa's dimensions** Check the width of gates, doors, and sidewalks to make sure your spa will pass through unobstructed.
- During delivery, the spa must remain on the delivery cart at all times. You may have to remove a gate or part of a fence to allow an unobstructed passageway to the installation location.
Note: To prevent damage to the panels and acrylic, if possible, leave the packaging on until the spa is in place.
- Plan the delivery route** After referring to Figure 2, plan your spa's delivery route into your yard. Check off each item on the checklist below to verify your plans.
- If the delivery route requires a 90° turn, check the measurements at the turn to ensure the spa will fit.
 - Are there protruding gas or water meters, or A/C units obstructing the delivery path to your yard? You must make sure that the spa has a clear unobstructed route and will not strike any objects on the path, therefore creating a detectable or non-detectable leak or damage.
 - Are there low roof eaves, overhanging branches, or rain gutters that could be an obstruction to overhead clearance?
 - Are there more than 6 consecutive stairs without a landing in your delivery route? If so, you must consult your Jacuzzi dealer prior to delivery to make adequate preparations.
- Use a crane** The use of a crane for delivery and installation is sometimes necessary. It is used primarily to avoid damage to your spa, your property, or to delivery personnel. Your authorized Jacuzzi dealer may be able to assist you with the arrangements. If your spa delivery requires the use of a crane, the cost of a crane is not included in standard delivery service.

Figure 2 Check for obstacles in the delivery route **BEFORE** receiving your new spa

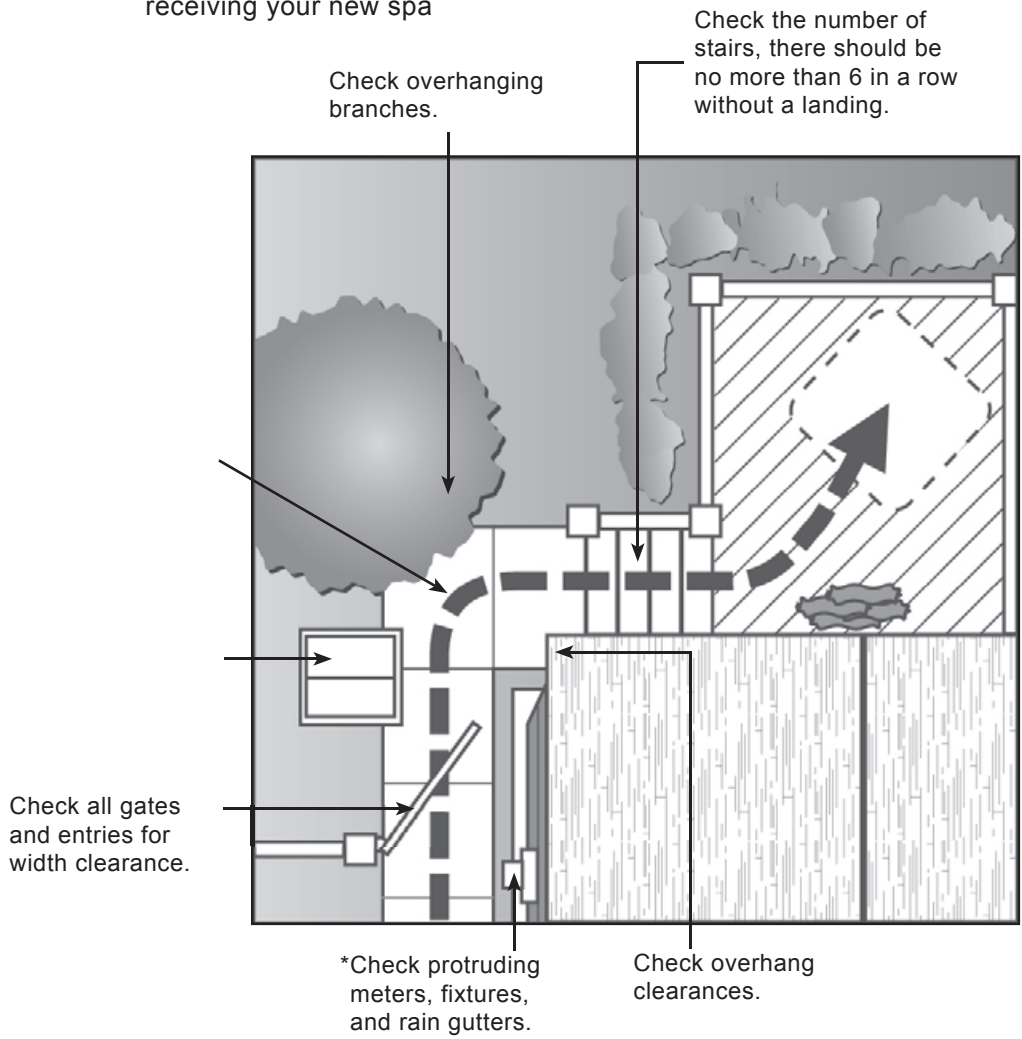

***CAUTION:** You must make sure that the spa has a clear unobstructed route and will not strike any objects on the path, therefore creating a detectable or non-detectable leak or damage.

Equipment Access Consideration for the J-LXL® and J-LX® Models

The J-LXL® and J-LX® models require a unique consideration when installing the spa within an enclosure. The equipment area is located beneath the control panel side. For these models the stainless steel corners must be removed before removing the front panel. It is strongly recommended that the corners be inverted and screwed back in with the square bit screws facing towards the front.

Unscrew the stainless steel corners and the synthetic corner underneath it. You will require a #2 square bit driver for the corner screws.

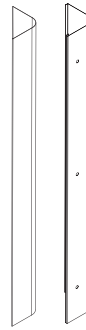
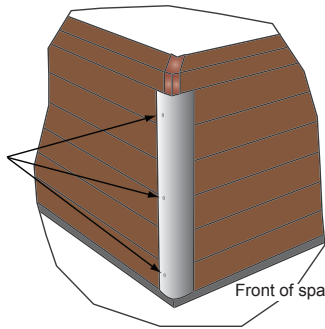

The corners consist of two parts:

- 1.) The stainless steel overlay;
- 2.) The synthetic corner

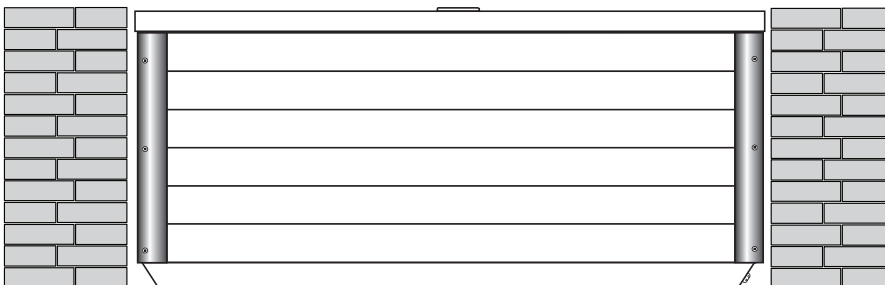
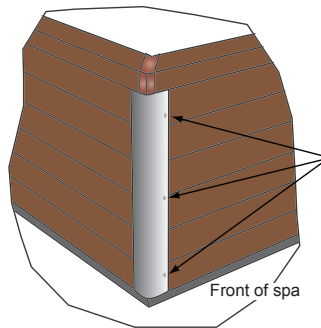

Spa equipment is now accessible without moving the spa out of the enclosure.

Electrical Tasks Before Spa Delivery

General Electrical System Considerations

Before the installation of your spa begins, check with the local building department to ensure this installation conforms to local building codes.

Important



When installed in the United States, the electrical wiring of this spa must meet the requirements of the National Electric Code (NEC) and any applicable state or local codes. The electrical circuit must be installed by an electrical contractor AND approved by a local building/electrical inspector.



⚠ DANGER: TO DECREASE THE RISK OF SHOCK, PRODUCT DAMAGE OR ELECTRICAL FIRE. Never use an extension cord of any kind. Using an extension cord can damage the spa equipment and void your warranty.

The Jacuzzi J-210, J-315, and J-325 North American models include a 10 foot GFCI cord for plug-in 120V operation. Connect this cord directly to a dedicated/grounded wall outlet. When a power cord over 10 ft. is required, the spas must be hard wired in accordance with state and local codes.

Before the scheduled arrival of your spa it is necessary to set up the electrical components of the hot tub. Use the checklist below to prepare for the spa installation.

- ◇ Prepare the electrical connection for your spa based on one of the configurations listed below. If necessary, refer to the Power Configuration tables for additional information by model.

If installing a spa that is...	Then it must be...
240V (North America)	Hard wired to the power supply.
120V (USA only)	Plugged into a dedicated grounded outlet using the 10' GFCI cord supplied with the spa.
120V (Canada)	Hard wired to the power supply per CSA standards.

Electrical Tasks Before Spa Delivery, *Continued*

To Keep Warranty Valid: The manufacturer's warranty becomes void if the spa's electrical connections do not meet the specifications as stated in this document.

- ◇ Verify the power supplied to the spa is on a dedicated circuit with no other appliances or lights sharing the power.
- ◇ Verify the electrician has completed the tasks listed below before the spa is delivered. If necessary, find the information requested by looking in the Power Configuration tables.

Task Complete?	Tasks for the electrician
◇	Select the wire size based on NEC and/or local codes. <div style="background-color: #e0e0e0; padding: 5px; margin-left: 20px;"> Note If you use wire larger than #6 (10 mm²), add a junction box near the spa, and reduce the wire to short lengths of #6 (10 mm²) wire between the junction box and the spa. </div>
◇	Determine the length of wire that is needed between the breaker box and the spa based on the wire size and the maximum current draw.
◇	Acquire enough copper wire with THHN insulation to ensure adequate connections. Do not use aluminum wire.

- ◇ To comply with Section 422-20 of the National Electric Code, ANSI/NFPA 70, the electrical supply for the spa must include a suitably rated switch or circuit breaker to open all ungrounded supply conductors. The means to disconnect the electricity must be readily accessible to the spa's occupant, but installed at least 5 ft. (1.5m) from the spa water. Check with local municipalities for additional code requirements.
- ◇ As required by NEC Article 680-42, the electrical circuit for the spa must include a suitable ground fault circuit interrupter (GFCI). We recommend Square-D or Cutler Hammer GFCI breakers. The appropriate wiring configuration for your spa appear elsewhere in this document.
- ◇ This spa is not intended nor designed to be used in a commercial or public application. The spa buyer shall determine whether there are any code restrictions on the use or installation of this spa since local code requirements vary from one locality to another.

Check the tables on the next few pages to match your hot tub model with one of the power configuration options.



Important: When installed in the United States, the electrical wiring of this spa must meet the requirements of the National Electric Code (NEC) and any applicable state or local codes. The electrical circuit must be installed by an electrical contractor AND approved by a local building/electrical inspector.

Power Configurations for Models J-495 (North America, 60Hz)

This section describes the three power configuration choices (Standard 50 Amp, Alternate 30 Amp, and Alternate 60 Amp) for hot tub models J-495.

Note Wire size must meet NEC recommendations and is determined by maximum current draw and length of run.

Important: All of the alternative electrical configurations require a qualified technician to perform a minor system modification. Do not activate 30A or 60A power to the spa until these modifications have been made. We recommend Square-D or Cutler Hammer circuit breakers.

Config. #1	<p>Standard 50A Configuration (factory setting)</p> <ul style="list-style-type: none">• 240 VAC/50A 3-wire configuration (2 hots and a ground)• 50A dual-pole GFCI circuit breaker (hard wired only)• Electrical current draw of 36A	<p>If the home's electrical system does not have the full 240V/60A power available, the spa may be connected to the standard 240V/50A.</p> <p>In this Standard 50A configuration, the heater will yield the same rapid temperature rise as in 60A operation and will not operate when two or more jets pumps are running.</p>
Config. #2	<p>Alternate 30A Configuration (For homes where 240 VAC/50A or 240 VAC/60A power is unavailable.)</p> <ul style="list-style-type: none">• 240 VAC/30A 3-wire configuration (2 hots and a ground)• 30A dual-pole GFCI circuit breaker (hard wired only)• Electrical current draw of 23A	<p>If the home's electrical system does not have a 240V/50A or 240V/60A power available, the spa may be connected to a 240V/30A power source after a qualified electrician performs a minor system modification.</p> <p>In this configuration, the heater will not operate while any jets pump is running.</p>
Config. #3	<p>Alternate 60A Configuration (Optional setting for maximum heater performance.)</p> <ul style="list-style-type: none">• 240 VAC/60A 3-wire configuration (2 hots and a ground)• 60A dual-pole GFCI circuit breaker (hard wired only)• Electrical current draw of 45A	<p>If the home's electrical system has the full 240V/60A power available, the spa may be connected to a 240V/60A power source after a qualified electrician performs a minor system modification.</p> <p>In this configuration, the heater will not operate when all three jets pumps are running. This may be preferable for owners of outdoor spas in cold climates because it will help their spas maintain water temperature during use.</p>



Important: When installed in the United States, the electrical wiring of this spa must meet the requirements of the National Electric Code (NEC) and any applicable state or local codes. The electrical circuit must be installed by an electrical contractor AND approved by a local building/electrical inspector.

Power Configurations for Models J-425, J-465, J-470, J-480 (North America, 60Hz)

This section describes the three power configuration choices (Standard 50 Amp, Alternate 30 Amp, and Alternate 60 Amp) for hot tub models J-465, J-470, J-480.

Note Wire size must meet NEC recommendations and is determined by maximum current draw and length of run.

Important: All of the alternative electrical configurations require a qualified technician to perform a minor system modification. Do not activate 30A or 60A power to the spa until these modifications have been made. We recommend Square-D or Cutler Hammer circuit breakers.

Config. #1	<p>Standard 50A Configuration (factory setting)</p> <ul style="list-style-type: none">• 240 VAC/50A 3-wire configuration (2 hots and a ground)• 50A dual-pole GFCI circuit breaker (hard wired only)• Electrical current draw of 36A	<p>If the home's electrical system does not have the full 240V/60A power available, the spa may be connected to the standard 240V/50A.</p> <p>In this Standard 50A configuration, the heater will yield the same rapid temperature rise as in 60A operation but <u>will not operate</u> while both jets pumps are running.</p>
Config. #2	<p>Alternate 30A Configuration (For homes where 240 VAC/50A or 240 VAC/60A power is unavailable.)</p> <ul style="list-style-type: none">• 240 VAC/30A 3-wire configuration (2 hots and a ground)• 30A dual-pole GFCI circuit breaker (hard wired only)• Electrical current draw of 23A	<p>If the home's electrical system does not have a 240V/50A or 240V/60A power available, the spa may be connected to a 240V/30A power source after a qualified electrician performs a minor system modification.</p> <p>In this configuration, the heater <u>will not operate</u> while either jets pump is running.</p>
Config. #3	<p>Alternate 60A Configuration (Optional setting for maximum heater performance.)</p> <ul style="list-style-type: none">• 240 VAC/60A 3-wire configuration (2 hots and a ground)• 60A dual-pole GFCI circuit breaker (hard wired only)• Electrical current draw of 45A	<p>If the home's electrical system has the full 240V/60A power available, the spa may be connected to a 240V/60A power source after a qualified electrician performs a minor system modification.</p> <p>In this configuration, the heater <u>will operate</u> while both jets pumps are running. This may be preferable for owners of outdoor spas in cold climates because it will help their spas maintain water temperature during use.</p>



Important: When installed in the United States, the electrical wiring of this spa must meet the requirements of the National Electric Code (NEC) and any applicable state or local codes. The electrical circuit must be installed by an electrical contractor AND approved by a local building/electrical inspector.

Power Configurations for Models J-415 (North America, 60Hz)

This section describes the two power configuration choices (Standard 50 Amp, Alternate and Alternate 30 Amp) for hot tub models J-415.

Note Wire size must meet NEC recommendations and is determined by maximum current draw and length of run.

Important: All of the alternative electrical configurations require a qualified technician to perform a minor system modification. Do not activate 30A power to the spa until these modifications have been made. We recommend Square-D or Cutler Hammer circuit breakers.

Config. #1	<p>Standard 50A Configuration (factory setting)</p> <ul style="list-style-type: none">• 240 VAC/50A 3-wire configuration (2 hots and a ground)• 50A dual-pole GFCI circuit breaker (hard wired only)• Electrical current draw of 36A	In this Standard 50A configuration, the heater <u>will operate</u> while the jets pump is running.
Config. #2	<p>Alternate 30A Configuration (For homes where 240 VAC/50A power is unavailable.)</p> <ul style="list-style-type: none">• 240 VAC/30A 3-wire configuration (2 hots and a ground)• 30A dual-pole GFCI circuit breaker (hard wired only)• Electrical current draw of 23A	If the home's electrical system does not have a 240V/50A power available, the spa may be connected to a 240V/30A power source after a qualified electrician performs a minor system modification. In this configuration, the heater <u>will not operate</u> while the jets pump is running.



Important: When installed in the United States, the electrical wiring of this spa must meet the requirements of the National Electric Code (NEC) and any applicable state or local codes. The electrical circuit must be installed by an electrical contractor AND approved by a local building/electrical inspector.

Power Configurations for Models J-LX® and J-LXL® (North America, 60Hz)

This section describes the three power configuration choices (Standard 50 Amp, Alternate 40 Amp, and Alternate 60 Amp) for hot tub models J-LX® and J-LXL®.

Note Wire size must meet NEC recommendations and is determined by maximum current draw and length of run.

Important: All of the alternative electrical configurations require a qualified technician to perform minor circuit board modifications. Do not activate 40A or 60A power to the spa until these modifications have been made. We recommend Square-D or Cutler Hammer circuit breakers.

Config. #1	<p>Standard 50A Configuration (factory setting)</p> <ul style="list-style-type: none"> • 240 VAC/50A 3-wire configuration (2 hots and a ground) • 50A dual-pole GFCI circuit breaker (hard wired only) • Maximum electrical current draw of 36A 	<p>In this Standard 50A configuration, the heater <u>will not operate</u> while both jets pumps are running in high speed.</p> <p>Jets Pump 2 runs only in high speed.</p>
Config. #2	<p>Alternate 40A Configuration (For homes where 240 VAC/50A or 240 VAC/60A power is unavailable.)</p> <ul style="list-style-type: none"> • 240 VAC/40A 3-wire configuration (2 hots and a ground) • 40A dual-pole GFCI circuit breaker (hard wired only) • Maximum electrical current draw of 26A 	<p>If the home's electrical system does not have the 240V/60A or 240V/50A power available, the spa may be connected to a 240V/40A power source after a qualified electrician makes a minor circuit board modification.</p> <p>In this configuration, the heater yields the same rapid temperature rise as in the 60A or 50A configuration, but <u>will not operate</u> while either jets pump is running in high speed.</p> <p>Jets Pump 2 runs only in high speed.</p>
Config. #3	<p>Alternate 60A Configuration (Optional setting for maximum heater performance.)</p> <ul style="list-style-type: none"> • 240 VAC/60A 3-wire configuration (2 hots and a ground) • 60A dual-pole GFCI circuit breaker (hard wired only) • Maximum electrical current draw of 45A 	<p>If the home's electrical system has the full 240V/60A power available, the spa may be connected to a 240V/60A power source after a qualified electrician makes a minor circuit board modification.</p> <p>In this configuration, the heater <u>will operate</u> while both jets pumps are running in high speed.</p> <p>Jets Pump 2 runs only in high speed.</p>



Important: When installed in the United States, the electrical wiring of this spa must meet the requirements of the National Electric Code (NEC) and any applicable state or local codes. The electrical circuit must be installed by an electrical contractor AND approved by a local building/electrical inspector.

Power Configurations for Models J-335, J-345, J-355, J-365, J-375, J-385 (North America, 60Hz)

This section describes the three power configuration choices (Standard 50 Amp, Alternate 40 Amp, and Alternate 60 Amp) for hot tub models J-335, J-345, J-355, J-365, J-375, J-385.

Note Wire size must meet NEC recommendations and is determined by maximum current draw and length of run.

Important: All of the alternative electrical configurations require a qualified technician to perform minor circuit board modifications. Do not activate 40A or 60A power to the spa until these modifications have been made. We recommend Square-D or Cutler Hammer circuit breakers.

Config. #1	<p>Standard 50A Configuration (factory setting)</p> <ul style="list-style-type: none"> • 240 VAC/50A 3-wire configuration (2 hots and a ground) • 50A dual-pole GFCI circuit breaker (hard wired only) • Maximum electrical current draw of 36A 	<p>In this Standard 50A configuration, the heater <u>will not operate</u> while both jets pumps are running in high speed.</p> <p>Jets Pump 2 runs only in high speed.</p>
Config. #2	<p>Alternate 40A Configuration (For homes where 240 VAC/50A or 240 VAC/60A power is unavailable.)</p> <ul style="list-style-type: none"> • 240 VAC/40A 3-wire configuration (2 hots and a ground) • 40A dual-pole GFCI circuit breaker (hard wired only) • Maximum electrical current draw of 26A 	<p>If the home's electrical system does not have the 240V/60A or 240V/50A power available, the spa may be connected to a 240V/40A power source after a qualified electrician makes a minor circuit board modification.</p> <p>In this configuration, the heater yields the same rapid temperature rise as in the 60A or 50A configuration, but <u>will not operate</u> while either jets pump is running in high speed.</p> <p>Jets Pump 2 runs only in high speed.</p>
Config. #3	<p>Alternate 60A Configuration (Optional setting for maximum heater performance.)</p> <ul style="list-style-type: none"> • 240 VAC/60A 3-wire configuration (2 hots and a ground) • 60A dual-pole GFCI circuit breaker (hard wired only) • Maximum electrical current draw of 45A 	<p>If the home's electrical system has the full 240V/60A power available, the spa may be connected to a 240V/60A power source after a qualified electrician makes a minor circuit board modification.</p> <p>In this configuration, the heater <u>will operate</u> while both jets pumps are running in high speed.</p> <p>Jets Pump 2 runs only in high speed.</p>



Important: When installed in the United States, the electrical wiring of this spa must meet the requirements of the National Electric Code (NEC) and any applicable state or local codes. The electrical circuit must be installed by an electrical contractor AND approved by a local building/electrical inspector.

Power Configurations for Models J-235, J-245, J-275, J-280 (North America, 60Hz)

This section describes the three power configuration choices (Standard 50 Amp, Alternate 40 Amp, or Alternate 60 Amp) for hot tub models J-235, J-245, J-275, and J-280.

Note Wire size must meet NEC recommendations and is determined by maximum current draw and length of run.

Important: All of the alternative electrical configurations require a qualified technician to perform minor circuit board modifications. Do not activate 40A or 60A power to the spa until these modifications have been made. We recommend Square-D or Cutler Hammer circuit breakers.

Config. #1	<p>Standard 50A Configuration (factory setting)</p> <ul style="list-style-type: none"> • 240 VAC/50A 3-wire configuration (2 hots and ground) • 50A dual-pole GFCI circuit breaker (hard wired only) • Maximum electrical current draw of 36A 	<p>In this Standard 50A configuration, the heater <u>will not operate</u> while both jets pumps are running in high speed.</p> <p>Jets Pump 2 runs only in high speed.</p>
Config. #2	<p>Alternate 40A Configuration (For homes where 240 VAC/50A or 240 VAC/60A power is unavailable.)</p> <ul style="list-style-type: none"> • 240 VAC/40A 3-wire configuration (2 hots and ground) • 40A dual-pole GFCI circuit breaker (hard wired only) • Maximum electrical current draw of 26A 	<p>If your home electrical service does not have 240V/50A power available, the spa may be connected to a 240V/40A power source after a qualified electrician makes a minor circuit board modification.</p> <p>In this configuration, the heater yields the same rapid temperature rise as in the 50A configuration, but <u>will not operate</u> while either jets pump is running in high speed.</p> <p>Jets Pump 2 runs only in high speed.</p>
Config. #3	<p>Alternate 60A Configuration</p> <ul style="list-style-type: none"> • 240 VAC/60A 3-wire configuration (2 hots and ground) • 60A dual-pole GFCI circuit breaker (hard wired only) • Maximum electrical current draw of 45A 	<p>For use only with Models J-235, J-245, J-275 and J-280</p> <p>In the Alternate 60A configuration, the heater <u>will operate</u> while both jets pumps are running in high speed.</p> <p>Jets Pump 2 runs only in high speed.</p>



Important: When installed in the United States, the electrical wiring of this spa must meet the requirements of the National Electric Code (NEC) and any applicable state or local codes. The electrical circuit must be installed by an electrical contractor AND approved by a local building/electrical inspector.

Power Configurations for Models J-210, J-315, J-325 (North America, 60Hz)

This section describes the three power configuration choices (Standard 120 VAC/15 Amp, Alternate 240 VAC/30 Amp, or Alternate 240 VAC/40 Amp) for hot tub models J-210, J-315, and J-325.

Note Wire size must meet NEC recommendations and is determined by maximum current draw and length of run.

Important: All of the alternative electrical configurations require a qualified technician to perform minor circuit board modifications. To prevent damage to the spa, do not activate 240V/30A or 240V/40A power to the spa until these modifications have been made. We recommend Square-D or Cutler Hammer circuit breakers.

Config. #1	<p>Standard 15A Configuration (factory setting)</p> <ul style="list-style-type: none">• 120 VAC/15A 3-wire configuration (hot, neutral, and ground)• 1 kW heater output• Use either the 15A GFCI power cord (supplied only for US models) or a 15A single-pole GFCI circuit breaker (not supplied)• Maximum electrical current draw of 12A	<p>In 15A configuration the heater <u>will not operate</u> when the high-speed jets pump is activated.</p> <p>Place the spa within 10 ft (3m) of a dedicated grounded, grounding-type electrical outlet so that the power cord supplied with the spa can be plugged directly into it.</p> <p>Use the power cord shipped from the factory. Using another power cord may cancel the warranty.</p> <p>If the spa is more than 10 ft (3m) from an outlet, it must be hard wired to a 15A single-pole GFCI breaker.</p>
Config. #2	<p>Alternate 30A Configuration</p> <ul style="list-style-type: none">• 240 VAC/30A 4-wire configuration (2 hots, neutral, and ground)• 4 kW heater output• 30A dual-pole GFCI circuit breaker (not supplied)• Maximum electrical current draw of 21A	<p>If the home's electrical system does not have the 240V/40A power available, the spa may be connected to a 240V/30A power source after a qualified electrician makes a minor circuit board modification.</p> <p>In this configuration, the heater yields the same rapid temperature rise as in the 40A configuration. However, the heater <u>will not operate</u> at the same time as the high-speed jets pump.</p>
Config. #3	<p>Alternate 40A Configuration</p> <ul style="list-style-type: none">• 240 VAC/40A 4-wire configuration (2 hots, neutral, and ground)• 4 kW heater output• 40A dual-pole GFCI circuit breaker (hard wired only)• Maximum electrical current draw of 30A	<p>In the Alternate 40A configuration, the heater <u>will operate</u> at the same time as the high-speed jets pump. It is necessary to have a qualified electrician modify the circuit board.</p>

Electrical Tasks After Spa Delivery

Installing a 3-Wire 240 VAC Connection for Models J-415, J-425, J-465, J-470, J-480 and J-495

 <p>DANGER Electric Shock and/or Electrocution hazard.</p>	<p>Important safety information for all spa models</p> <p>Proper grounding is extremely important. This spa is equipped with a Current Collector system. A pressure securing wire connector is provided on the outside of the load box to permit connection of a bonding wire between the spa and any metal within 5 ft. (1.5m) of the spa. Bonding wire must be at least #8 AWG (8.4 mm²) solid copper wire.</p>
--	---

After the spa is placed in the specified location, the electrician must perform the tasks listed below to complete the electrical installation. Give this information to the electrician when he begins to install your spa.

IMPORTANT: When installed in the United States, the electrical wiring of this spa must meet the requirements of the National Electric Code (NEC) and any applicable state or local codes. The electrical circuit must be installed by an electrical contractor AND approved by a local building/electrical inspector.

Task	Action
1	To gain access to the spa's power terminal strip, remove the spa cabinet panel on the side of the spa under the control panel (see Figure 3 on the next page). After removing the spa cabinet panel, remove the four metal access door cover screws.
2	Locate the power supply inlet (front of the spa near the base). Select the inlet you want to use, then feed the power cable through to the control box, Figure 4.
3	Insert the power cable through the large opening provided at the bottom of the control box.
4	Connect the wires onto the Green terminal block and securely fasten.
5	To complete the electrical installation, secure the access door cover by replacing its 4 screws, then re-install the spa cabinet panel under the control panel.

For specific electrical information about the spa model being installed, look through Figures 3 through 5 in this section.

Electrical Tasks After Spa Delivery, *Continued*

The electrician should look carefully through these diagrams to gather the required information about the electrical tasks for the installation of these spas.

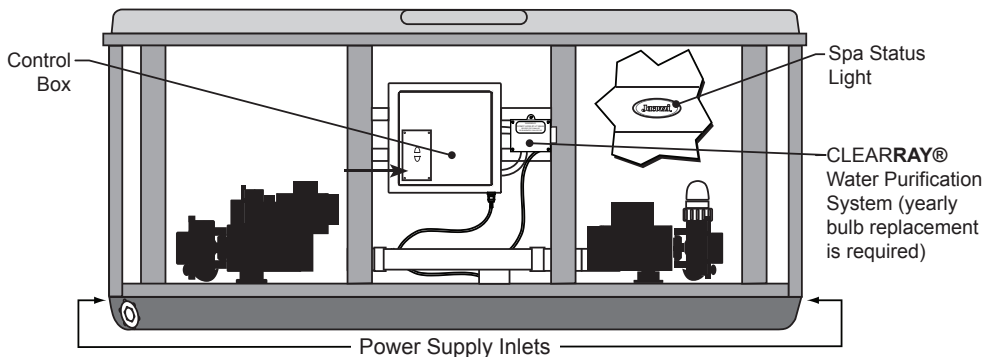

Figure 3 Spa Equipment Compartment (spa features subject to change without notice)

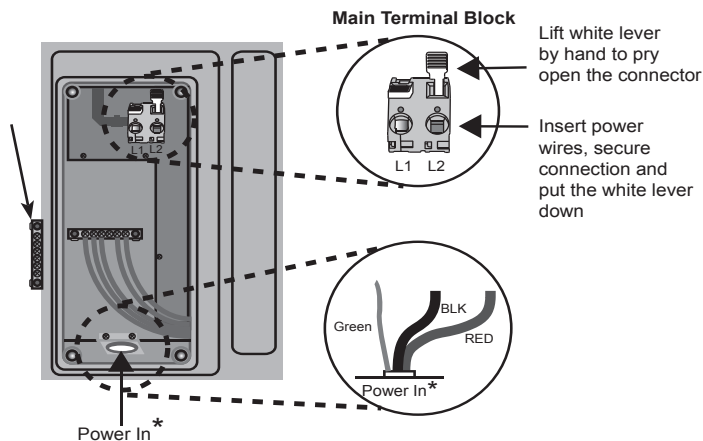

Figure 4 Control Box for 3-Wire, 240 VAC Connection for Models J-415, J-425, J-465, J-470, J-480 and J-495 (For hard-wired connections only)

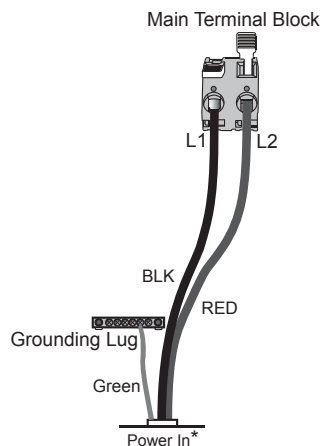

Figure 5 3-Wire, 240 VAC Connection for Models J-415, J-425, J-465, J-470, J-480 and J-495 (For hard-wired connections only)

Installing a 3-Wire 240 VAC Connection for Models J-LX® and J-LXL®



Important safety information for all spa models

Proper grounding is extremely important. This spa is equipped with a Current Collector system. A pressure securing wire connector is provided on the outside of the load box to permit connection of a bonding wire between the spa and any metal within 5 ft. (1.5m) of the spa. Bonding wire must be at least #8 AWG (8.4 mm²) solid copper wire.

After the spa is placed in the specified location, the electrician must perform the tasks listed below to complete the electrical installation. Give this information to the electrician when he begins to install your spa.

Task	Action
1	To gain access to the spa's power terminal strip, remove the stainless steel corner panels (first) and then the front panel(s); on the side of the spa under the control panel. The corner panels use a square drive screw, make sure you have a square drive bit on hand (Figure 6, page 24). After removing the spa cabinet panel, remove the four metal control box cover screws and metal control box cover.
2	Locate the power supply inlet (front of the spa near the base). Select the inlet you want to use, then feed the power cable through to the control box.
3	Insert the power cable through the large opening provided on the left side of the metal control box.
4	Connect the wires, color to color, on the terminal strips and tighten securely.
5	To complete the electrical installation, secure the metal control box door by replacing its 4 screws, then re-install the spa cabinet panel(s) under the control panel.

For specific electrical information about the spa model being installed, look through Figures 6 through 9 in this section.

Installing a 3-Wire 240 VAC Connection for Models J-LX® and J-LXL®

The electrician should look carefully through these diagrams to gather the required information about the electrical tasks for the installation of these spas.

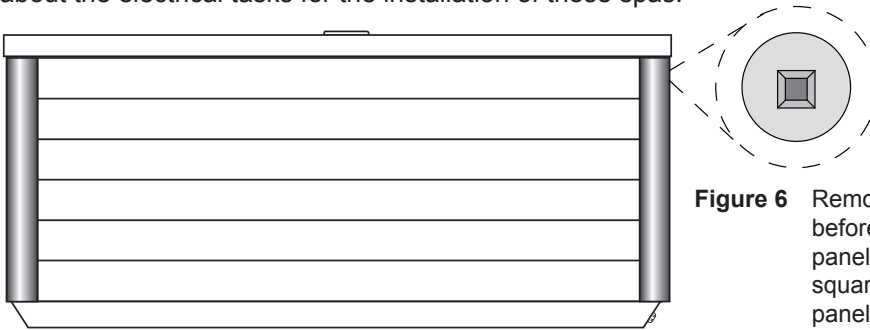

Figure 6 Remove the corner panels before removing the front panel(s). You will need a #2 square bit driver for the corner panels.

Figure 7 Spa Equipment Compartment (spa features subject to change without notice)

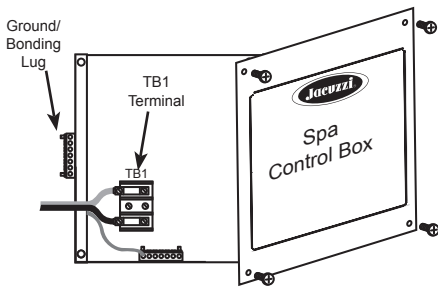
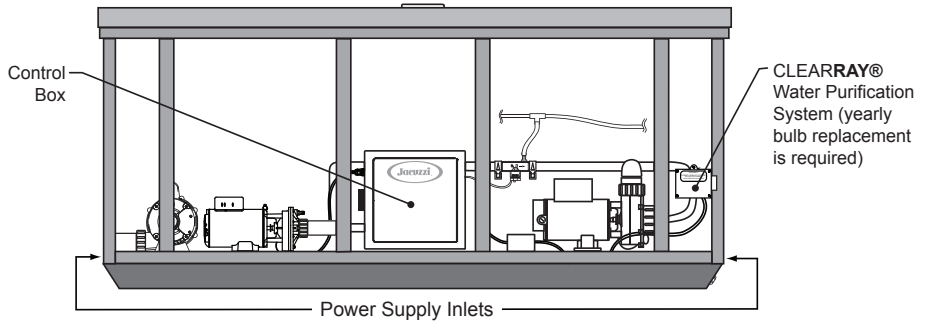

Figure 8 The Control Box for 3-wire, 240 VAC connection. (The location of the TB1 terminal may vary between models.)

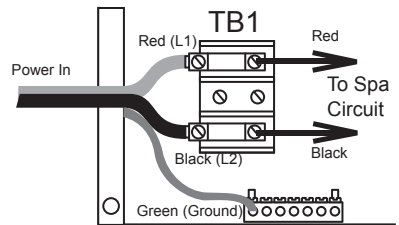

Figure 9 3-Wire, 240 VAC Connection (Hard-wired connections only)

Installing a 3-Wire 240 VAC Connection for Models J-235, J-245, J-275, J-280, J-335, J-345, J-355, J-365, J-375, J-385

DANGER



Electric Shock
and/or
Electrocution
hazard.

Important safety information for all spa models

Proper grounding is extremely important. This spa is equipped with a Current Collector system. A pressure securing wire connector is provided on the outside of the load box to permit connection of a bonding wire between the spa and any metal within 5 ft. (1.5m) of the spa. Bonding wire must be at least #8 AWG (8.4 mm²) solid copper wire.

After the spa is placed in the specified location, the electrician must perform the tasks listed below to complete the electrical installation. Give this information to the electrician when he begins to install your spa.

Task	Action
1	To gain access to the spa's power terminal strip, remove the spa cabinet panel on the side of the spa under the control panel (see Figure 10 on the next page). After removing the spa cabinet panel, remove the four metal control box cover screws and metal control box cover.
2	Locate the power supply inlet (front of the spa near the base). Select the inlet you want to use, then feed the power cable through to the control box.
3	Insert the power cable through the large opening provided on the left side of the metal control box.
4	Connect the wires, color to color, on the terminal strips and tighten securely.
5	To complete the electrical installation, secure the metal control box door by replacing its 4 screws, then re-install the spa cabinet panel under the control panel.

For specific electrical information about the spa model being installed, look through Figures 10 through 12 in this section.

Installing a 3-Wire 240 VAC Connection for Models J-235, J-245, J-275, J-280, J-335, J-345, J-355, J-365, J-375, J-385

The electrician should look carefully through these diagrams to gather the required information about the electrical tasks for the installation of these spas.

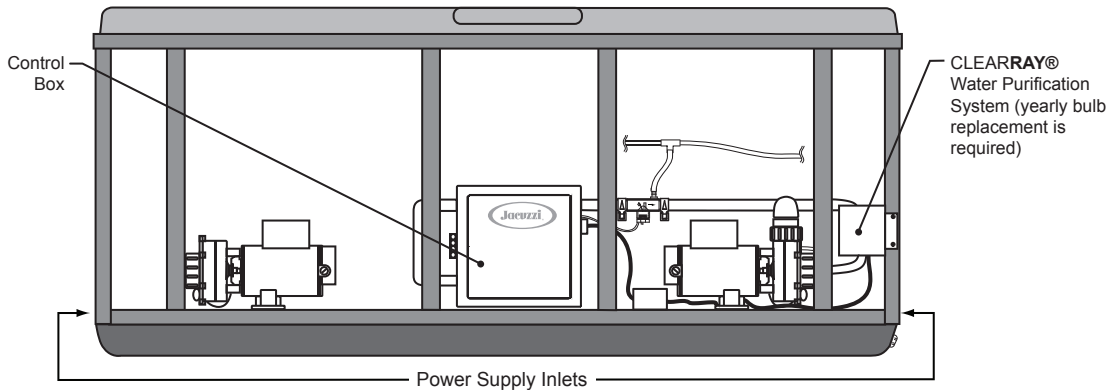

Figure 10 Spa Equipment Compartment (spa features subject to change without notice)

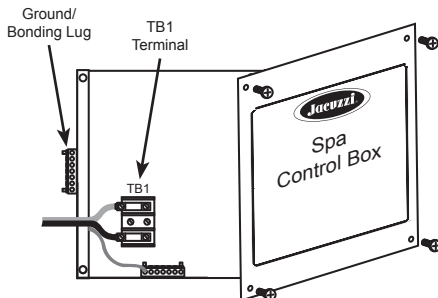

Figure 11 The Control Box for 3-wire, 240 VAC connection

The location of the TB1 terminal may vary between models.

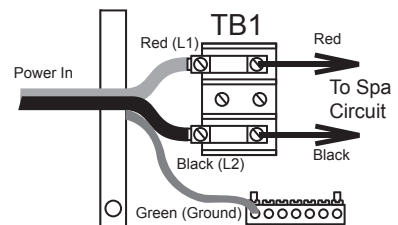



Figure 12 3-Wire, 240 VAC Connection for Models J-235, J-245, J-275, J-280, J-335, J-345, J-355, J-365, J-375, J-385 (For hard-wired connections only)

Installing a 3-Wire 120 VAC or 4-Wire 120/240 VAC Connection for Models J-210, J-315, J-325

 <p>DANGER Electric Shock and/or Electrocution hazard.</p>	<p>Important safety information for all spa models</p> <p>Proper grounding is extremely important. This spa is equipped with a Current Collector system. A pressure securing wire connector is provided on the outside of the load box to permit connection of a bonding wire between the spa and any metal within 5 ft. (1.5m) of the spa. Bonding wire must be at least #8 AWG (8.4 mm²) solid copper wire.</p>
--	---

After the spa is placed in the specified location, the electrician must perform the tasks listed below to complete the electrical installation. Give this information to the electrician when he begins to install your spa.

Task	Action
1	To gain access to the spa's power terminal strip, remove the spa cabinet panel on the side of the spa under the control panel (see Figure 13 on the next page). After removing the spa cabinet panel, remove the four metal control box cover screws and metal control box cover.
2	Locate the power supply inlet (front of the spa near the base). Select the inlet you want to use, then feed the power cable through to the control box.
3	Insert the power cable through the large opening provided on the left side of the metal control box.
4	Connect the wires, color to color, on the terminal strips and tighten securely.
5	To complete the electrical installation, secure the metal control box door by replacing its 4 screws, then re-install the spa cabinet panel under the control panel.

For specific electrical information about the spa model being installed, look through Figures 13 through 16 in this section.

Installing a 3-Wire 120 VAC or 4-Wire 120/240 VAC Connection for Models J-210, J-315, J-325

The electrician should look carefully through these diagrams to gather the required information about the electrical tasks for the installation of these spas.

Figure 13 The Spa Equipment Compartment (spa features subject to change without notice)

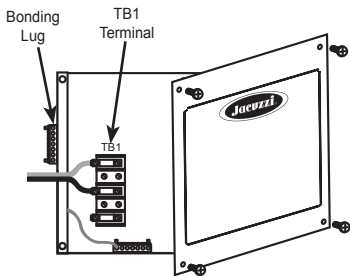
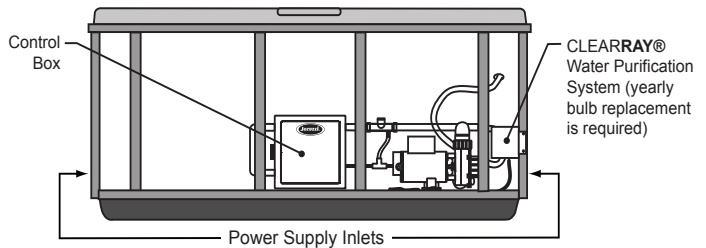

Figure 14 The Control Box for Models J-210, J-315, and J-325

The 3-wire, 120 VAC connection is illustrated. The location of the TB1 terminal may vary between models.

Figure 15 3-wire, 120 VAC Connection for Models J-210, J-315, and J-325

Use the supplied GFCI cord for installations in the USA. Otherwise, hard wire a 3-wire connection.

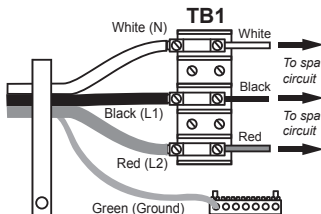
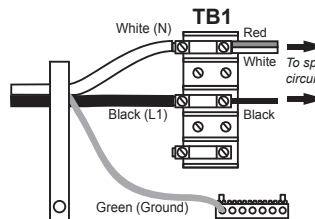

Figure 16 4-wire, 240 VAC Connection for Models J-210, J-315, and J-325

For hard-wired connections, move the RED wire to terminal position #3 as shown.

Final Electrical Connections

It is now time to make the final electrical connections to your spa. Various wiring diagrams appear on the next few pages. Each spa model has a slightly different configuration, so use the chart below to find the configuration for your spa.

Configuration #	Details
1	240 VAC Connections for Models (North America 60Hz): <ul style="list-style-type: none">• J-415, J-425, J-465, J-470, J-480, J-495
2	240 VAC Connections for Models (North America 60Hz): <ul style="list-style-type: none">• J-235, J-245, J-275, J-280• J-335, J-345, J-355, J-365, J-375, J-385• J-LX®, J-LXL®
3	120 VAC Connections for Models (North America 60Hz): <ul style="list-style-type: none">• J-210, J-315, J-325
4	240 VAC Connections for Models (North America 60Hz): <ul style="list-style-type: none">• J-210, J-315, J-325

Ask your electrician to view the diagrams on the next few pages to ensure all connections are correct.



Important: When installed in the United States, the electrical wiring of this spa must meet the requirements of the National Electric Code (NEC) and any applicable state or local codes. The electrical circuit must be installed by an electrical contractor AND approved by a local building/electrical inspector.

Connection Configuration #1 240 VAC Connections for Models J-415, J-425, J-465, J-470, J-480, J-495 (North America 60Hz)

A pressure sensitive terminal block (bonding lug) is attached to the outside surface of the load box. This permits the connection of a bonding wire between this point and any metal equipment chassis, metal water pipe, or metal conduit within 5 ft (1.5m) of the spa. The bonding wire must be at least #8 AWG (8.4 mm²) solid copper wire.

A 2-Pole Circuit Breaker with 2-Wire Grounded Load Connection (3 Wires to Hot Tub, 2-Hot (L1-L2), 1-Ground)

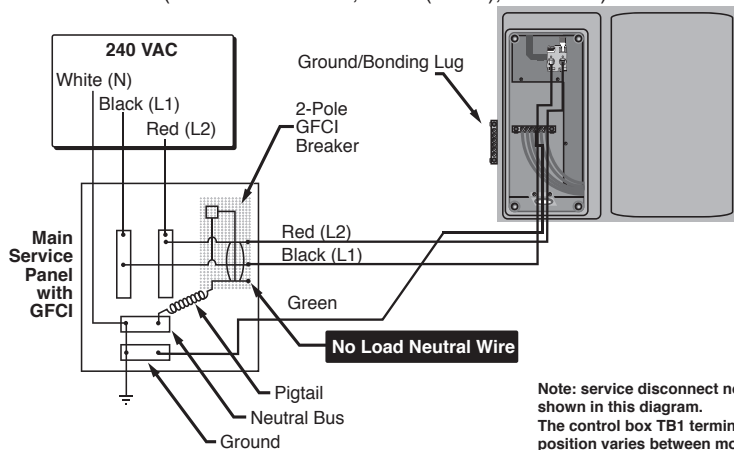

B Main Panel with Secondary GFCI Shut-Off Box Using a 2-Pole GFCI Breaker with 2-Wire Grounded Connection (3 Wires to Hot Tub, 2-Hot (L1-L2), 1-Ground)

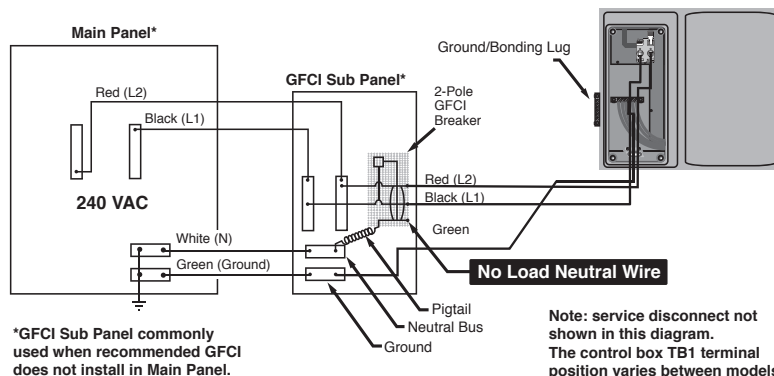

Connection Configuration #2

240 VAC Connections for Models J-235, J-245, J-275, J-280, J-335, J-345, J-355, J-365, J-375, J-385, J-LX®, J-LXL® (North America 60Hz)

A pressure sensitive terminal block (bonding lug) is attached to the outside surface of the load box. This permits the connection of a bonding wire between this point and any metal equipment chassis, metal water pipe, or metal conduit within 5 ft (1.5m) of the spa. The bonding wire must be at least #8 AWG (8.4 mm²) solid copper wire.

**2-Pole Circuit Breaker with 2-Wire Grounded Load Connection
(3 Wires to Hot Tub, 2-Hot (L1-L2), 1-Ground)**

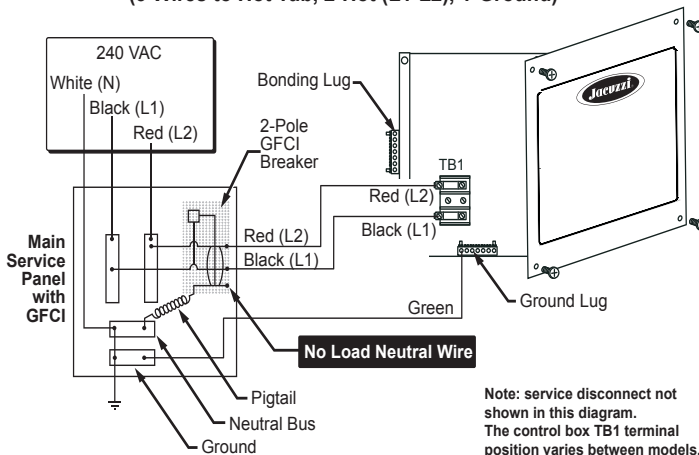

**Main Panel with Secondary GFCI Shut-Off Box Using a
2-Pole GFCI Breaker with 2-Wire Grounded Connection
(3 Wires to Hot Tub, 2-Hot (L1-L2), 1-Ground)**

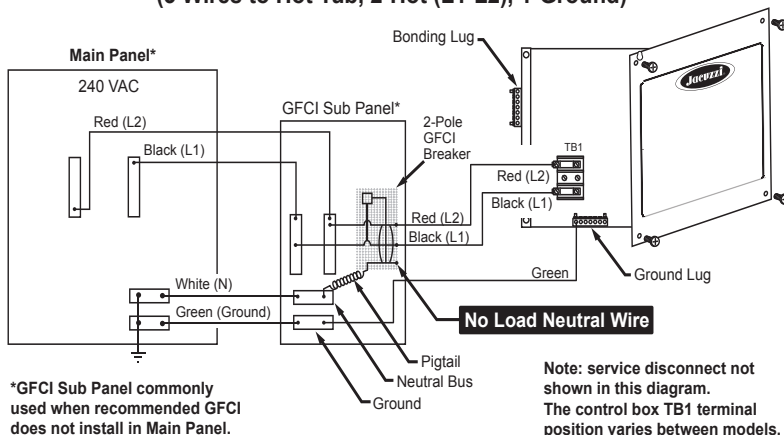

Connection Configuration #3

120 VAC Connections for Models J-210, J-315, J-325 (North America 60Hz)

If the supplied 10 ft GFCI power cord (US only) can not reach a dedicated, grounded wall outlet, it is necessary to install a 3-wire, hard-wired connection. These diagrams illustrate that configuration.

For enhanced heater performance the use of a 4-wire 240 VAC power connection is necessary.

1-Pole Circuit Breaker with 3-Wire Grounded Load Connection
(3 Wires to Hot Tub, 1-Hot (L), 1-Neutral (N), 1-Ground)

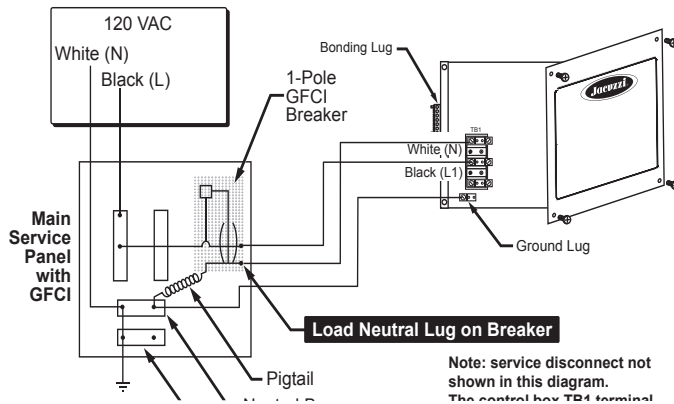

A pressure sensitive terminal block (bonding lug) is attached to the outside surface of the load box. This permits the connection of a bonding wire between this point and any metal equipment chassis, metal water pipe, or metal conduit within 5 ft (1.5m) of the spa. The bonding wire must be at least a #8 AWG (8.4 mm²) solid copper wire.

Main Panel with Secondary GFCI Shut-Off Box Using a 1-Pole GFCI Breaker with 2-Wire Grounded Load Connection
(3 Wires to Hot Tub, 1-Hot (L1), 1-Neutral (N), 1-Ground)

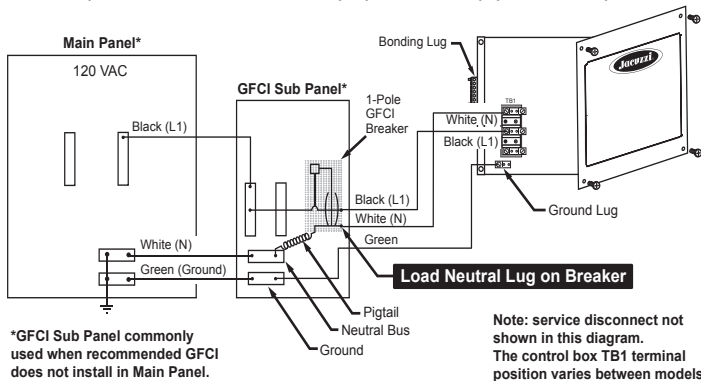

Connection Configuration #4

240 VAC Connections for Models J-210, J-315, J-325 (North America 60Hz)

A pressure sensitive terminal block (bonding lug) is attached to the outside surface of the load box. This permits the connection of a bonding wire between this point and any metal equipment chassis, metal water pipe, or metal conduit within 5 ft (1.5m) of the spa. The bonding wire must be at least #8 AWG (8.4 mm²) solid copper wire.

**2-Pole Circuit Breaker with 3-Wire Grounded Load Connection
(4 Wires to Hot Tub, 2-Hot (L1-L2), 1-Neutral (N), 1-Ground)**

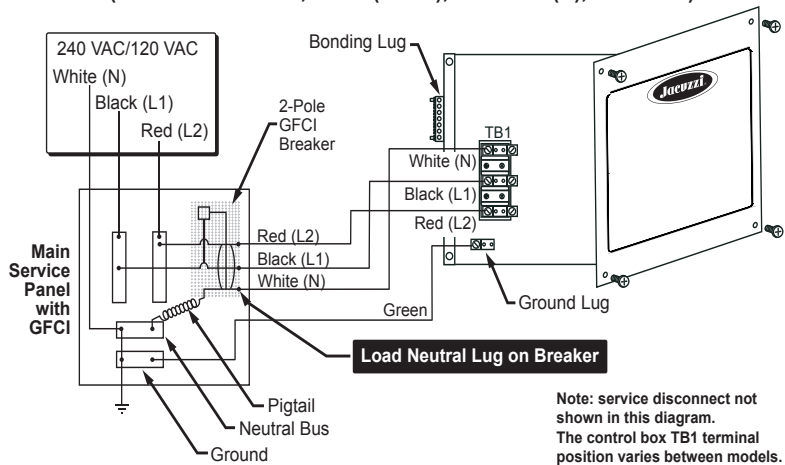

**Main Panel with Secondary GFCI Shut-Off Box Using a
2-Pole GFCI Breaker with 3-Wire Grounded Load Connection
(4 Wires to Hot Tub, 2-Hot (L1,L2), 1-Neutral (N), 1-Ground)**

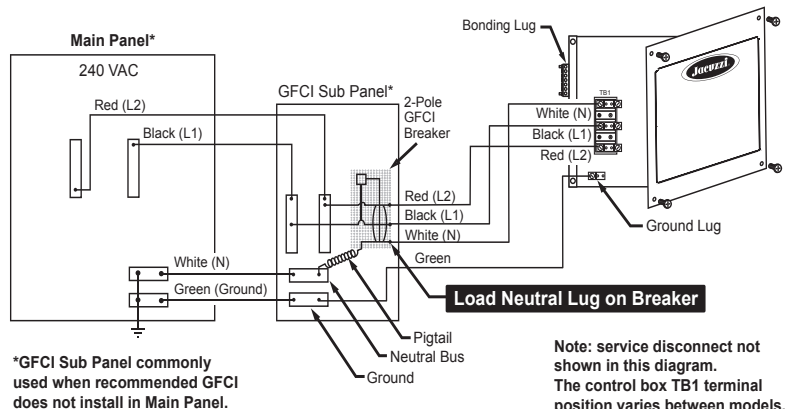

Spa Dimensions and Specifications

Useful Details About the Spa

The table below provides the spa dimensions and specifications that may be helpful when installing your spa. These specifications are approximate. The filled weight specifications vary depending on the height of the spa's water. The filled weight is the weight of the spa (empty), plus the weight of the water at its maximum potential capacity (filled to the point of overflowing). The filled weight specifications do not include the weight of potential hot tub users who might be inside the hot tub. To ensure proper operation, the spa's water should always be above all the jets, and approximately one inch below all the pillows.

NOTE Always measure your spa before making critical design or delivery pathway decisions. These specifications are subject to change without notice and are for reference only.

Model	Width	Length	Max. Height	Average Filled Weight	Min. Pad Size
J-495	90 in. (229 cm)	110 in. (279 cm)	46 in. (116 cm)	5809 lb. (2635 kg)	4 in. (102 mm)
J-480	94 in. (239 cm)	94 in. (239 cm)	44 in. (112 cm)	5004 lb. (2270 kg)	
J-470	91 in. (231 cm)	91 in. (231 cm)	44 in. (112 cm)	4703 lb. (2133 kg)	
J-465	88 in. (223.5 cm)	88 in. (223.5 cm)	43 in. (109 cm)	4325 lb. (1962 kg)	
J-425	76 in. (193 cm)	87 in. (221 cm)	39 in. (99 cm)	3632 lb. (1647 kg)	
J-415	66 in. (168 cm)	76 in. (193 cm)	32 in. (81 cm)	2503 lb. (1135 kg)	
J-385	91 in. (231 cm)	91 in. (231 cm)	38 in. (96.5 cm)	5086 lb. (2307 kg)	
J-375	91 in. (231 cm)	91 in. (231 cm)	38 in. (96.5 cm)	4817 lb. (2185 kg)	
J-365	91 in. (231 cm)	84 in. (213.5 cm)	38 in. (96.5 cm)	4538 lb. (2058 kg)	
J-355	91 in. (231 cm)	84 in. (213.5 cm)	38 in. (96.5 cm)	4172 lb. (1892 kg)	
J-345	84 in. (213.5 cm)	84 in. (213.5 cm)	36 in. (91.5 cm)	3850 lb. (1746 kg)	
J-335	84 in. (213.5 cm)	84 in. (213.5 cm)	36 in. (91.5 cm)	3756 lb. (1704 kg)	
J-325	76 in. (193 cm)	84 in. (213.5 cm)	34 in. (86.5 cm)	3350 lb. (1520 kg)	
J-315	76 in. (193 cm)	66 in. (168 cm)	32 in. (81 cm)	2298 lb. (1042 kg)	
J-280	90 in. (229 cm)	90 in. (229 cm)	37 in. (94 cm)	4721 lb. (2142 kg)	
J-275	90 in. (229 cm)	90 in. (229 cm)	36 in. (92 cm)	4310 lb. (1955 kg)	
J-245	84 in. (214 cm)	84 in. (214 cm)	36 in. (92 cm)	3829 lb. (1737 kg)	
J-235	84 in. (214 cm)	84 in. (214 cm)	36 in. (92 cm)	3720 lb. (1688 kg)	
J-210	78 in. (198 cm)	78 in. (198 cm)	36 in. (91.5 cm)	2529 lb. (1147 kg)	
J-LX®	84 in. (213.5 cm)	84 in. (213.5 cm)	36 in. (91.5 cm)	4129 lb (1873 kg)	
J-LXL®	84 in. (213.5 cm)	84 in. (213.5 cm)	36 in. (91.5 cm)	4149 lb. (1882 kg)	

Water Capacity and Average Fill Volume

Water Capacity reference For Chemicals

* Use approximate average fill for chemical measurement

Model	*Average Fill Volume
J-495	560 US gal. (2120 Liters)
J-480	480 US gal. (1817 Liters)
J-470	450 US gal. (1703 Liters)
J-465	410 US gal. (1552 Liters)
J-425	340 US gal. (1287 Liters)
J-415	230 US gal. (871 Liters)
J-385	500 US gal. (1893 Liters)
J-375	470 US gal. (1779 Liters)
J-365	440 US gal. (1666 Liters)
J-355	400 US gal. (1514 Liters)
J-345	370 US gal. (1401 Liters)
J-335	360 US gal. (1363 Liters)
J-325	330 US gal. (1249 Liters)
J-315	215 US gal. (814 Liters)
J-280	460 US gal. (1741 Liters)
J-275	420 US gal. (1590 Liters)
J-245	360 US gal. (1363 Liters)
J-235	360 US gal. (1363 Liters)
J-210	240 US gal. (908 Liters)
J-LX®	390 US gal. (1476 Liters)
J-LXL®	390 US gal. (1476 Liters)

- Total Spa Volume is the approximate measurement of water it takes to fill the total area inside the spa.
- Average Fill is the approximate measurement of water used to cover all jets but does not touch the bottom of the lowest headrest.

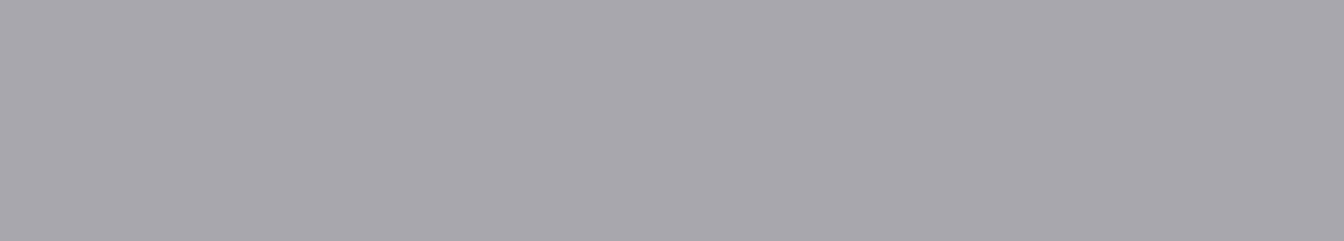

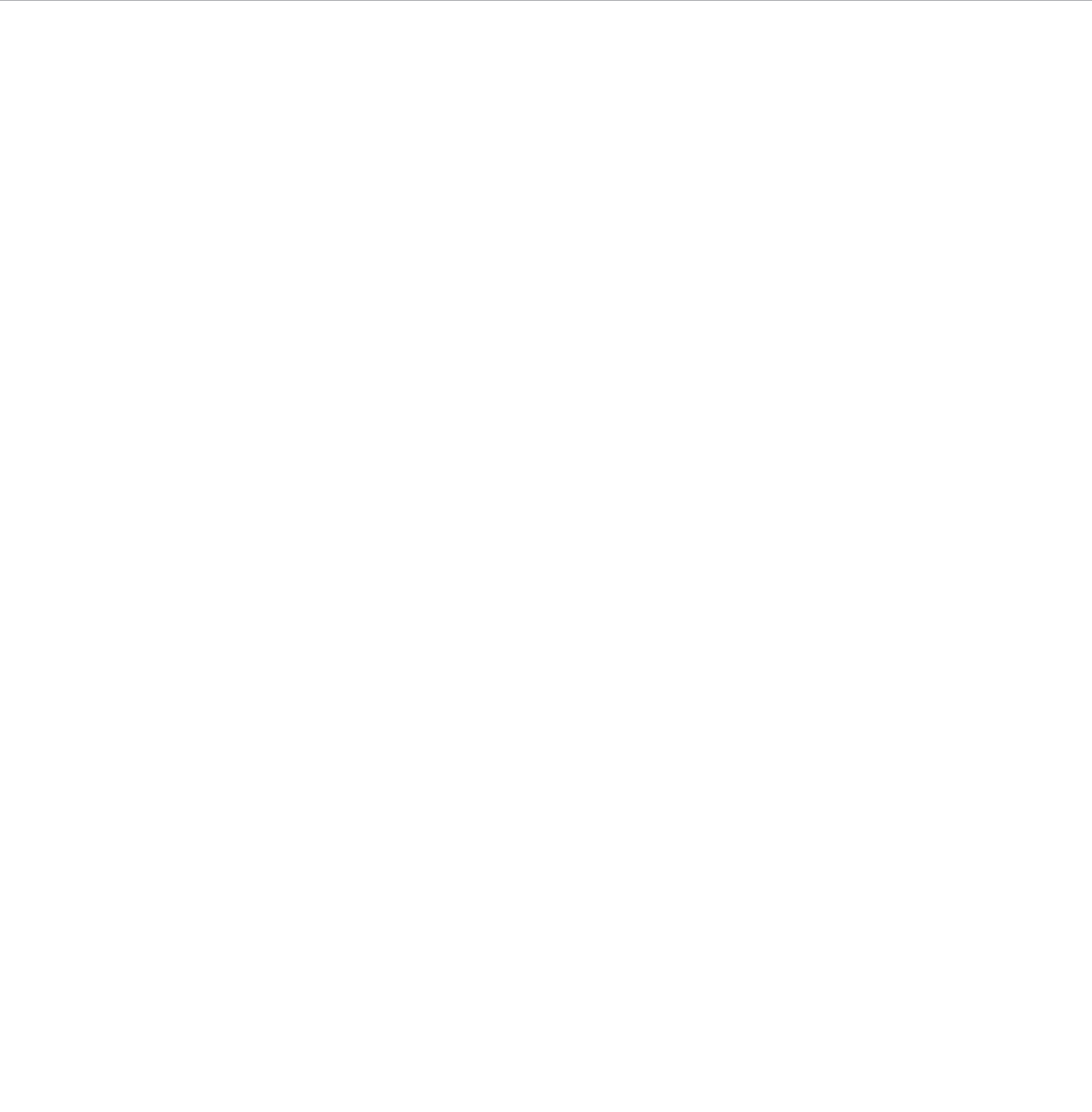
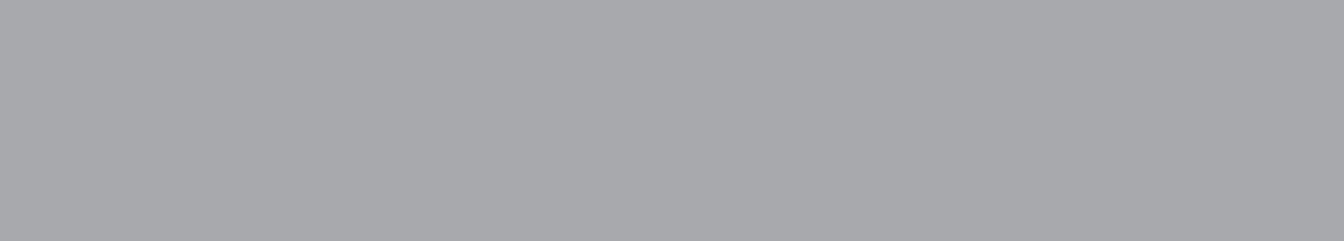

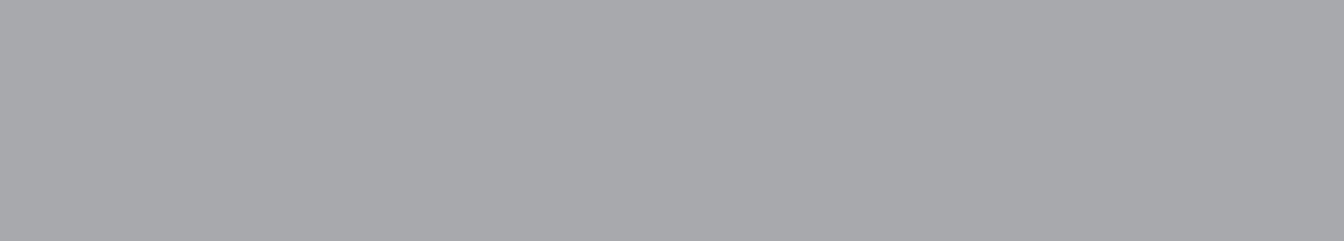

Your Jacuzzi Hot Tubs Dealer is:



www.jacuzzi.com
14525 Monte Vista Avenue, Chino, CA 91710 / U.S.A.

P/N 2890-215AENG Rev. A 01/14

©2014 USA, Jacuzzi Hot Tubs. All rights reserved.