

MATERIAL SPECIFICATIONS

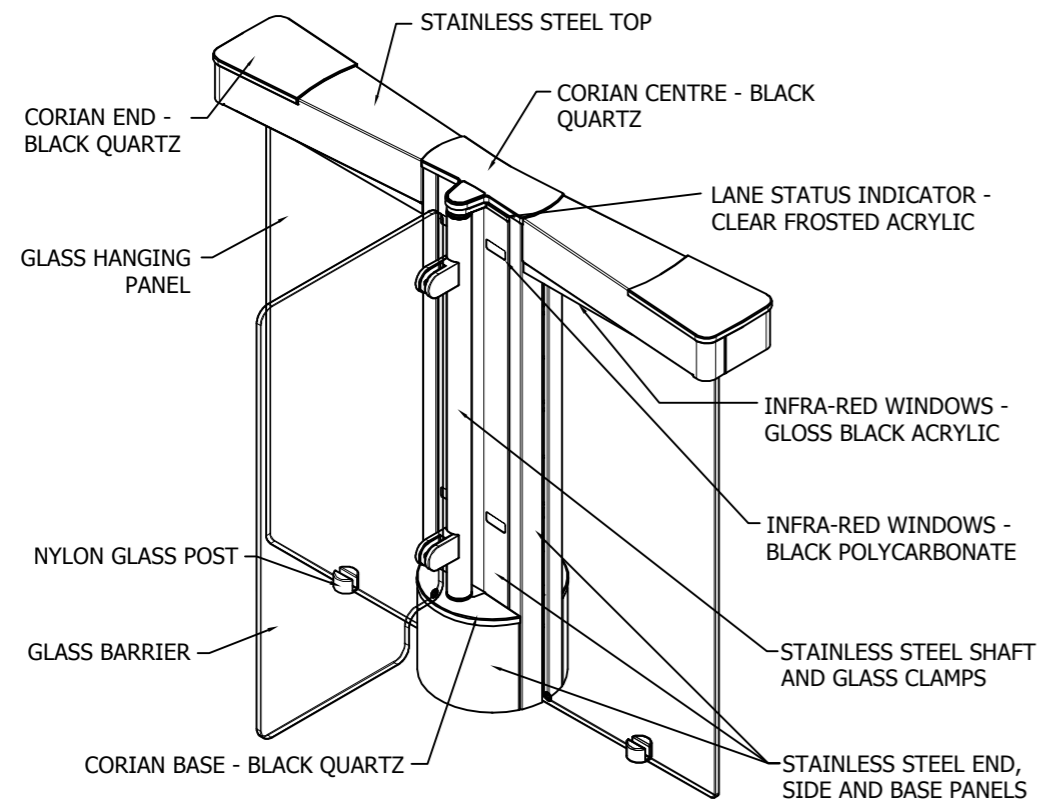

ALL GLASS IS TOUGHENED - EN14179
 ALL STAINLESS STEEL IS 304 GRADE SATIN FINISH AND 240 GRIT WITH HORIZONTAL GRAIN

READER MOUNTING OPTIONS

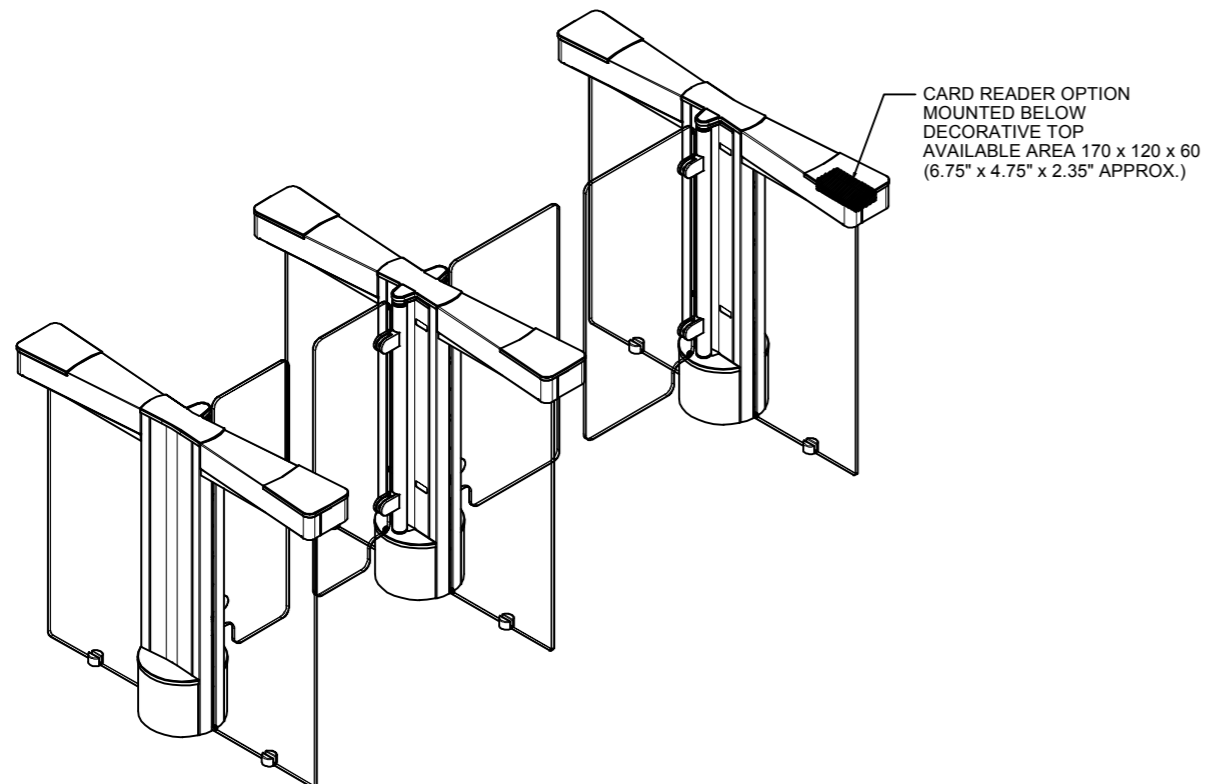

LANE LAYOUT & GENERAL DIMENSIONS

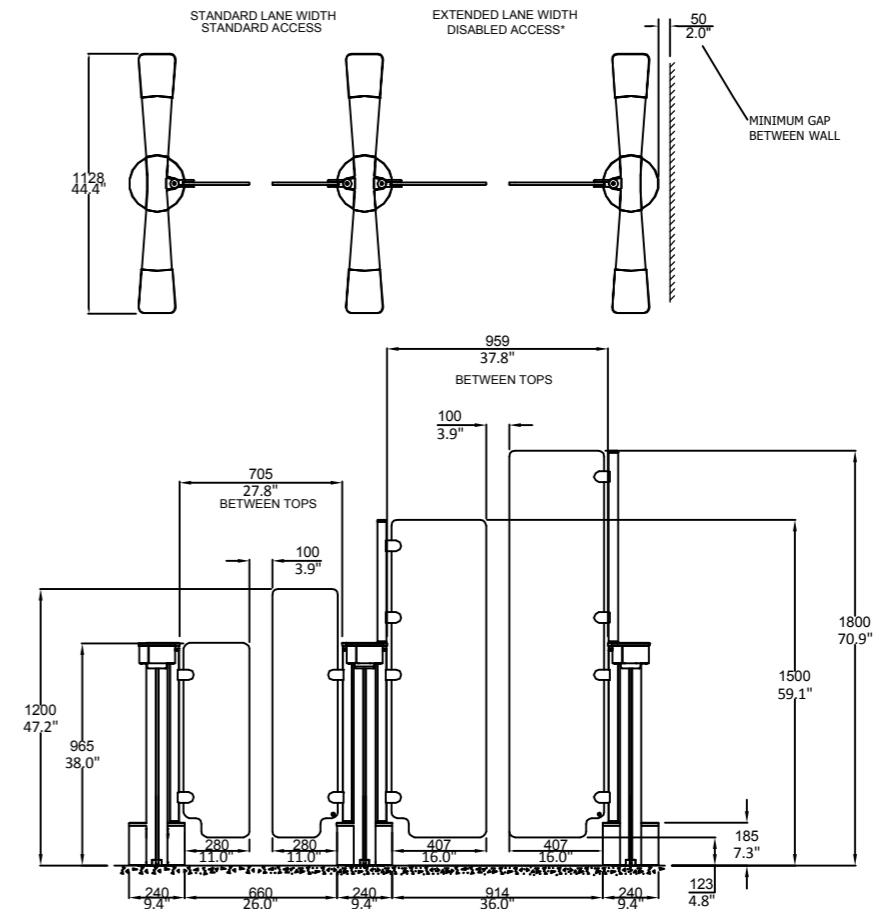

*SUBJECT TO LOCAL LEGISLATION

LANE WIDTH	HEIGHT OPTIONS			
660mm (STD ACCESS)	965mm	1200mm	1500mm	1800mm
914mm (DDA ACCESS)	965mm	1200mm	1500mm	1800mm

PEDESTAL FIXING LOCATIONS

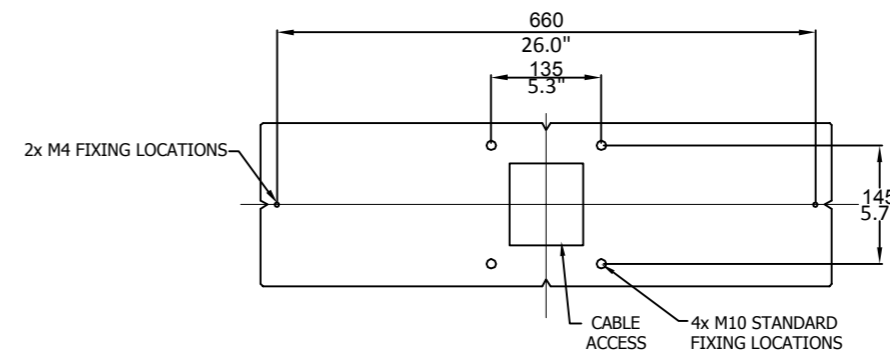

PRODUCT: GLASSGATE 300 V2

TITLE: GENERAL INFORMATION

DRAWING No: GG300 V2_A2

FOR SALES INFORMATION ONLY-SUBJECT TO CHANGE
 ALL DIMENSIONS +/- 2MM

This document is the copyright of Integrated Design Ltd

