

Fastlane 400 OT

Key Features

■ Dimensions	Standard	Wheelchair
	(L) 973 mm / 38.3" (W) 168 mm / 6.6" (H) 965 mm / 38"	(L) 973 mm / 38.3" (W) 168 mm / 6.6" (H) 965 mm / 38"
■ Lane Width	600 - 700 mm 23 - 28"	850 - 960 mm 33 - 38"
■ Shape of Unit	Square (Round option available)	
■ Number of Infra-red Beams	18	
■ Barrier Type	None	
■ Barrier Position	N/A	
■ Barrier Height	Standard – N/A	Options – N/A
■ Primary Operating Mode	Barrier Free	
■ Wheelchair Access	Pedestals installed further apart No cost implication	
■ Distance to *		
	Detect Tailgaters	5 mm / 0.25"
Physically Impede Tailgaters	N/A	
■ Speed of Throughput	1 person per second (subject to access system)	
■ User Display	Tri-Colour End of Lane LEDs	
■ Customisable Features	Decorative Tops at extra cost	
	(Standard: Low Iron White Backed Glass)	
	Pedestal Shapes, (S)quare or (R)ound	
■ Safety Features	Enclosure Materials at extra cost	
	Barrier Free	



The Fastlane 400 OT has been designed with security and architectural flexibility in mind. The 400 OT comes with 18 individual IR beam paths for unsurpassed detection performance. The product features a range of enclosure and decorative top finishes in addition to integral card reader mounting options, to easily blend the pedestal into the fabric of the building design. The Fastlane 400 OT utilises Cat 5 interconnections between the pedestals to simplify and speed up installation.

Secure
Fastlane offers a similar level of security as a ½ height turnstile and is designed to alert security staff to unauthorised entry attempts by triggering an audible alarm and controlling other security measures such as CCTV systems, lighting and locking doors. Fastlane activates an alarm in the event of an illegal action i.e. if an unauthorised person attempts to enter. Fastlane is also designed to detect the following: **Tailgating** - people who attempt to enter without a valid access card by following closely behind an authorised cardholder; **Collusion & Obstruction** - Fastlane alarms when two individuals actively collude to gain entry with a single card, or where beams are deliberately blocked; **Pass-back** - helps to enforce the 'one card, one person, one direction' rule, assisting the access control system to maintain 'anti pass-back' integrity; **Non-entry** - Fastlane can detect when a card is presented but a person does not pass through the channel.

User-friendly
The absence of a physical barrier ensures fast throughput (up to one person per second) and unrestricted movement for all personnel, with safe disabled access and emergency egress. Users are greeted by an intuitive user interface, which automatically guides the user through the entry and exit procedure, ensuring fast easy access for authorised users.

www.fastlane-turnstiles.com

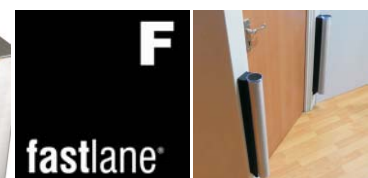

Setting New Standards In Entrance Control



Unit Information

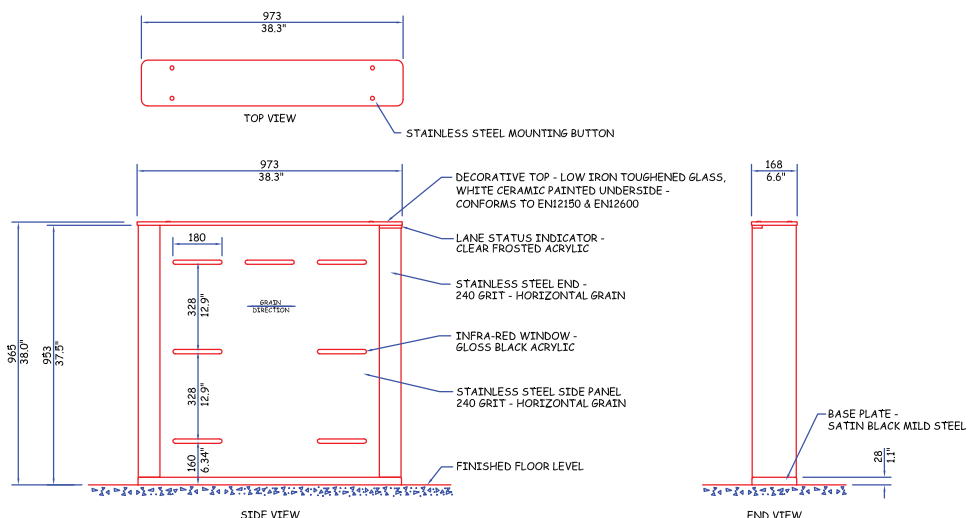

Technical Specifications

- Power Requirements:**
Remote Power Supply Input Voltage 100-240Vac, 50-60Hz, 60VA
- Optics:**
Optical Turnstile - pulsed multi infra-red beam array, 18 beam paths, synchronised for detection.
- User Interface:**
Tri Colour LED display
- Sounders:**
Single Tone Sounder: Card Authorisation
Multi Tone Variable Volume Sounder: Alarm Condition
- Inputs:**
Require voltage-free switching (current sense 1mA typical)
Entry Request (NORMALLY OPEN)
Exit Request (NORMALLY OPEN)
Visitor Access (NORMALLY OPEN)
- Outputs:**
Voltage free relay contacts rated 0.5A, 28V dc in two groups for the following functions:
Output to System:
Entry (NORMALLY CLOSED opening for 1 second)
Exit (NORMALLY CLOSED opening for 1 second)
Alarm (NORMALLY CLOSED opening for 1 second)
- Flow Control and Alarm Outputs:**
Ready for Entry (NORMALLY CLOSED, NORMALLY OPEN, COMMON poles)
Ready for Exit (NORMALLY CLOSED, NORMALLY OPEN, COMMON poles)
Remote Alarm (NORMALLY OPEN)
- Lane width:**
Standard: 600-700 mm (23-28 inches)
Disabled: 860-960 mm (33-38 inches)
- Speed of Throughput:**
1 person per second typical. (Subject to access control system)
- Tailgate Detection Distance:**
5 mm (0.25 inch)
- Modes:**
Bi-Directional Card In/Card Out On Demand
Bi-Directional Card In/Free Exit
Enter Only/Exit Only
Lane Closed
- Turnstile Operation:**
As defined in the Factory Acceptance Test Specification

Card Reader Mounting Options

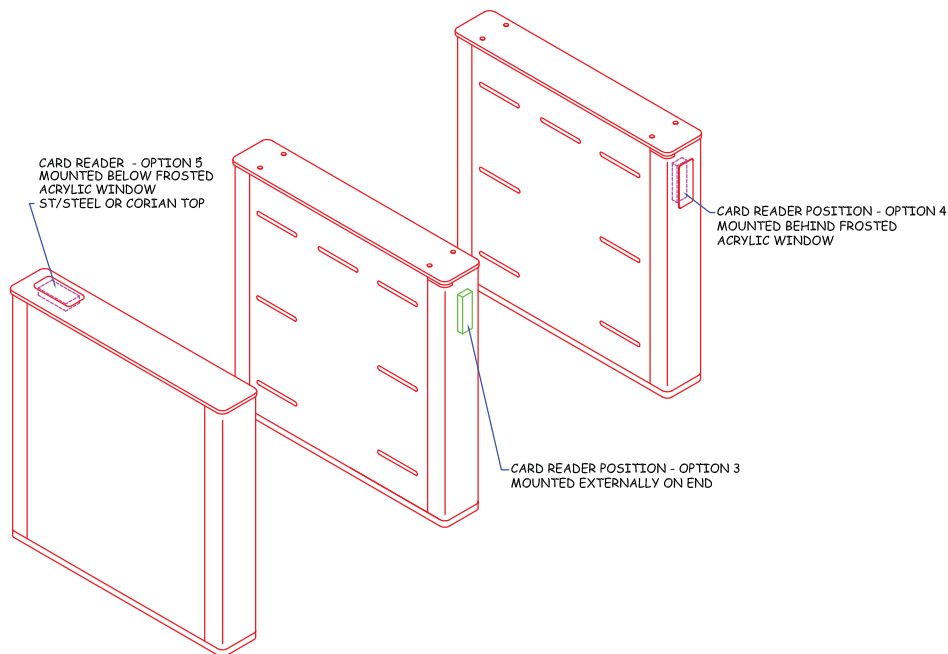

Specification subject to change without prior notice.

Disabled Access

Fastlane's combination of audible and visual sounders coupled with 'wheelchair width' lane options make Fastlane compliant with most international disabilities regulations without the need for a separate passgate.

Easy Installation

Fastlane has been designed with easy installation and low maintenance in mind and can be integrated into any existing access control or building management system. Fastlane can be used in conjunction with most card reading technologies, making it ideal for both new installations and retrofits in to existing buildings.

For further information please contact your local dealer or the manufacturer.

ISSUE DATE 19/05/10

*Subject to speed of users Installation photos may not represent current production models

Accessories and Optional Extras

Fastlane Floor Protector

The Fastlane Floor Protector system is designed for temporary installations and enables Fastlanes to be installed quickly and cost effectively, without drilling or otherwise damaging the floor on which they stand.

Fastlane Infill System

The Fastlane Infill System is a series of decorative modular panels, which complement the Fastlane and Fastlane plus turnstiles by guiding users in the desired direction.

Fastlane Remote Control

This desk mounted controller is designed to allow the guard to override some of the features of the Fastlanes, facilitate visitor entry and to give a visual indication of alarms at the guard desk.

Card Reader Mounting

A number of alternative card reader mounting options are available.

Alternative material and colour finishes

IDL offers a full design service for custom enclosures, as well as alternative colours and materials.



Manufactured by:
Integrated Design Ltd
Feltham Point
Browells Lane
Feltham
Middlesex
TW13 7EQ, UK

t: +44 (0) 208 890 5550
f: +44 (0) 208 890 2444
e: info@idl.co.uk
w: www.idl.co.uk

w: www.fastlane-turnstiles.com