

# Countertop Integrator Pro Tablet Kiosk

Secure counter mount tablet kiosk designed to securely enclose 10"-12" tablets. With space for additional devices such as receipts printers and contactless card readers.



Product Code: 019\_10\_000



019\_10\_000



## Product Features

- Fits Most Tablets with 10" - 12" Screens
- Fits a wide range of OEM & Peripheral Devices
- Future Proof Tablet Tray System
- Can be Bolted to any Surface for Greater Security
- Can be Mounted to our Floorstanding Graphic Panel Pedestal (additional fee)
- Steel & Plastic Construction
- Secure Power Adaptor Enclosure
- Discreet Cable Management System
- Continuous Power Charging Access
- Easy to Assemble
- Fast and Simple Tablet Loading
- Fully Brandable Bezel
- Custom Colours Available
- Easy Device Access for Servicing
- Optional Tablet Feature Access
- Transportable

## Colour Options

					Brandable
Bezel	✓	✓		✓	✓
Enclosure	✓	✓		✓	
Stand	✓	✓		✓	

## Tablet Configuration Options

Concealed Camera / Concealed Home Button

Concealed Camera / Revealed Home Button

Revealed Camera / Concealed Home Button

Revealed Camera / Revealed Home Button

# Countertop Integrator Pro Tablet Kiosk

Secure counter mount tablet kiosk designed to securely enclose 10"-12" tablets. With space for additional devices such as receipts printers and contactless card readers.



Product Code: 019\_10\_000

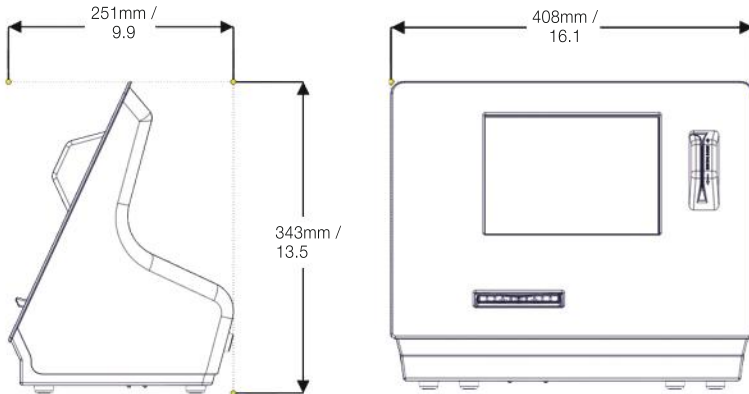

The Integrator Pro 10"-12" can be used to integrate peripheral devices such as scanners, readers, connectors and cables etc.

Other tablets and devices can be enclosed, contact us to discuss your requirements.

## 12" Tablets

iPad Pro (12.9) Samsung Galaxy TabPro S  
Microsoft Surface Pro 3,  
Pro 4 Dell Venue 11  
Linx 12

## 10" Tablets

iPad 2, 3, 4, Air, Air 2,  
Pro 9.7  
Microsoft Surface 3  
Samsung Galaxy Tab 3/4  
(10.1), Tab S (10.5),  
Tab A (9.7), Tab E (9.6),  
Tab S2 (9.7) Note (10.1)  
Google Nexus 9, 10  
Lenovo ThinkPad 10  
(2nd Gen)  
Linx 10-10 & 10-20

## Devices

Contactless Card Reader  
Swipe Card Reader  
Barcode Scanner  
Bluetooth/Wifi Dongle  
USB Hubs  
Power Supplies  
Readers/Scanners  
Finger Print Scanner

## Product Dimensions

251 x 408 x 343 mm

9.9 x 16.1 x 13.5 inches

## Packaged Dimensions

380 x 480 x 300 mm

15 x 18.9 x 11.8 inches

## Product Weight

(Excluding Devices)

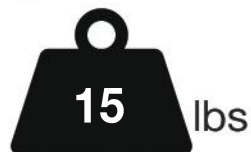

## Packaged Weight



## Materials

Bezel: Acrylic or  
Powder Coated Steel

Enclosure: Steel & ABS

## Tools

Provided: None

Required:  
Drill, Rawl Plugs (Surface Dependant)  
Phillips Screw Driver

## Assembly & Installation

Initial Setup Time:  
20 Minutes (1 person)

Tablet Fitting Time:  
1 Minute