

HunterDouglas

Installation • Operation • Care

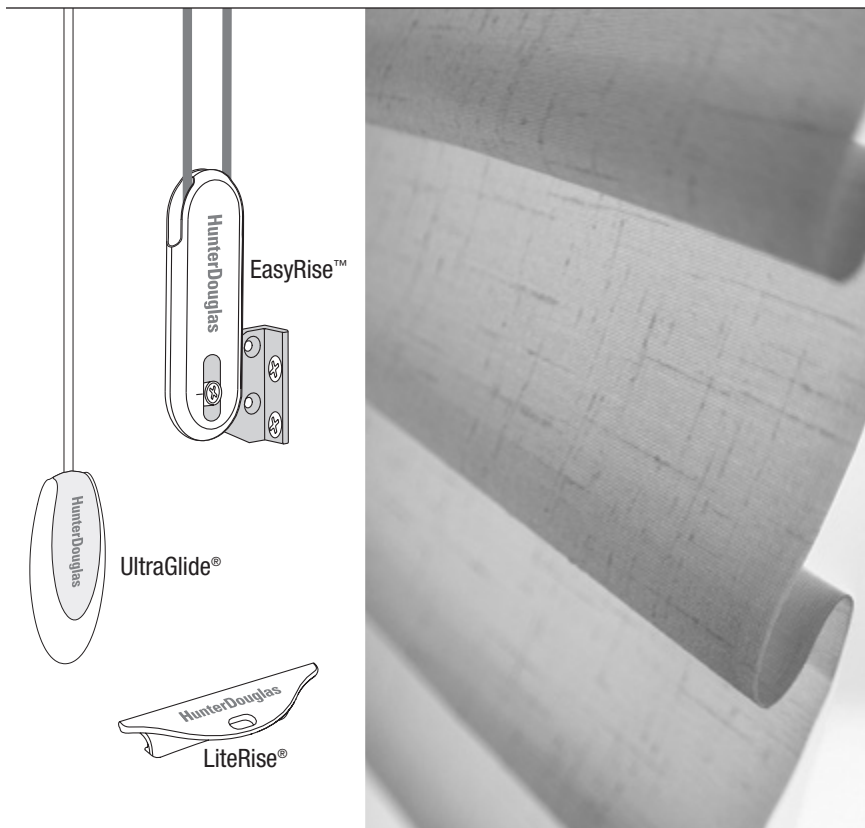

Vignette® Modern Roman Shades
Traditional™ Style
EasyRise, LiteRise, and UltraGlide
Operating Systems

CONTENTS

Getting Started:

Product View — Traditional™ Style EasyRise™ Shades	1
Product View — Traditional Style UltraGlide® Shades.....	2
Product View — Traditional Style LiteRise® Shades	3
Tools and Fasteners Needed	4

Installation:

Installation Overview	5
Mount the Installation Brackets — Inside Mount.....	6
Mount the Installation Brackets — Outside Mount	7
Mount the Installation Brackets — End Mount.....	8
Install the Shade	9
Attach the Universal Cord Tensioner — EasyRise Shades Only ...	10
Cord Adjustment — UltraGlide Shades Only	11
Install the Pull Tassel (Optional for LiteRise Shades Only)	11
Attach the Magnetic Hold-Down Brackets (Optional)	12

Operation:

Operate the Shade	13
Troubleshooting	15

Care:

Removing the Shade (If Necessary)	17
Cleaning Procedures	17

Child Safety:

Warning	19
Cord Loop Shades.....	19

Questions?

Call the Hunter Douglas Customer Information Center at
1-888-501-8364.

Product View — Traditional™ Style EasyRise™ Shades

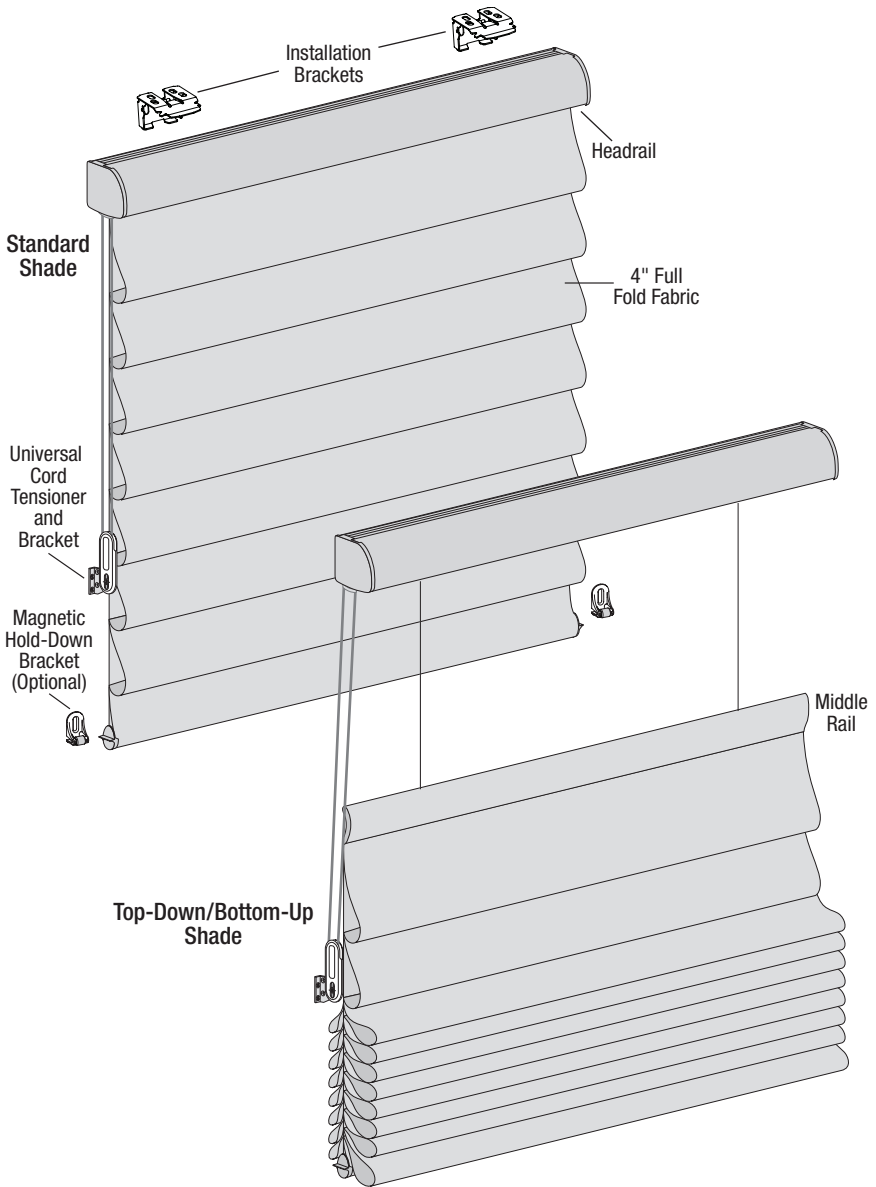

Not Shown: 6" Flat Fold and Two-on-One Headrail Shades

GETTING STARTED

Product View — Traditional™ Style UltraGlide® Shades

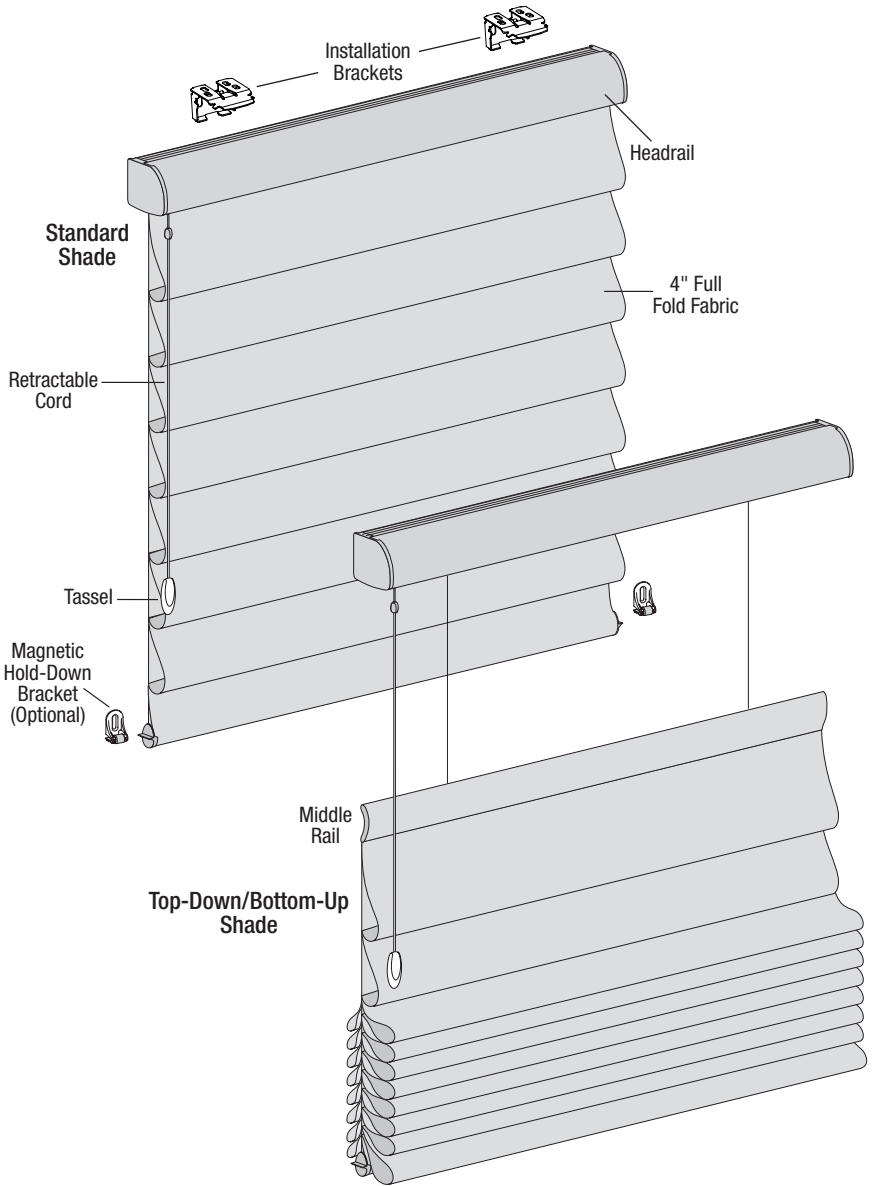

Not Shown: 6" Flat Fold and Two-on-One Headrail Shades

Product View — Traditional™ Style LiteRise® Shades

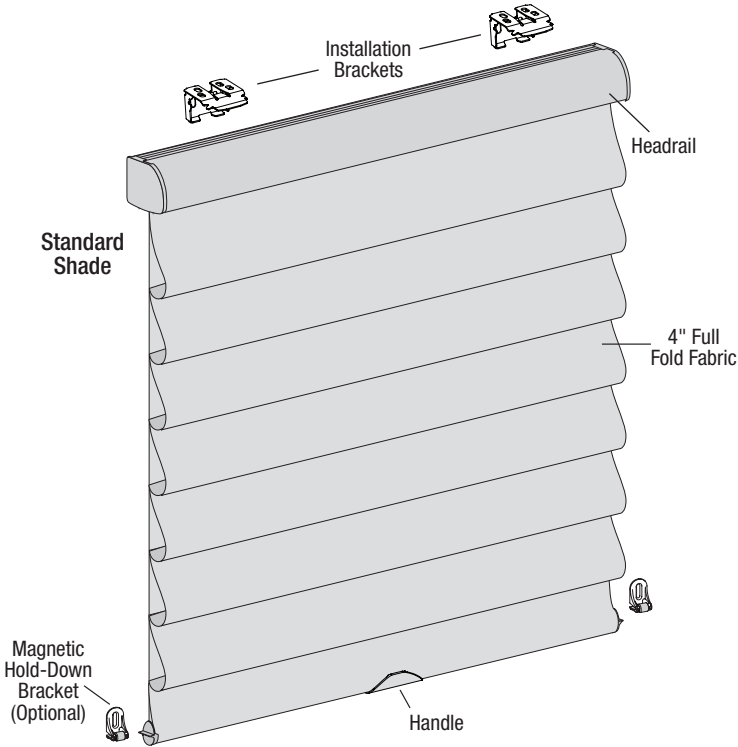

Not Shown: 6" Flat Fold, Two-on-One Headrail Shades, and Optional Pull Tassel

GETTING STARTED

Thank you for purchasing Hunter Douglas Vignette® Modern Roman Shades. With proper installation, operation and care, your new shades will provide years of beauty and performance.

Please thoroughly review this instruction booklet and the enclosed packing list before beginning the installation. If your shade has a protective plastic cover on the fabric-covered headrail, keep the plastic in place until the shade is installed.

Tools and Fasteners Needed

- Flat blade and Phillips screwdrivers
- Level (laser level is recommended)
- Measuring tape and pencil
- Needlenose pliers
- Power drill, $\frac{3}{32}$ " drill bit, and $\frac{1}{4}$ " hex driver

In addition, you will need fasteners designed to work with your specific mounting surface(s).

- **#6 Hex Head Screws (Provided).** Two $1\frac{1}{2}$ " screws are provided per installation bracket.
- **Longer Hex Head Screws (Not Provided).** If using spacer blocks, use #6 screws long enough for a secure attachment. Add $\frac{1}{2}$ " length for each spacer block.
- **Speed Nuts and Screws (Provided).** Extension brackets (for end mounts only) come with screws and speed nuts.
- **Drywall Anchors (Not Provided).** Use drywall anchors when mounting into drywall.



**#6 x 1 $\frac{1}{2}$ "
Hex Head Screw**
(Provided)



**Longer #6 Hex Head Screw
for Use with Spacer Blocks**
(Not Provided)



**Speed Nut
and Screw**
(Two Provided with
Each Extension Bracket)

Installation Overview

- Your order will include installation brackets specific to your shade.
 - The number of installation brackets required varies with shade width, as shown in the table below.

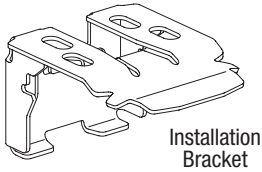

Shade Width	Brackets Required
12" – 36"	2
36 1/8" – 72"	3
72 1/8" – 108"	4
108 1/8" – 140"	5

Mounting Types and Window Terminology

If the installation brackets are mounted correctly, the rest of the installation process follows easily. To prepare for this important first step, review the mounting types and basic window terminology illustrated below.

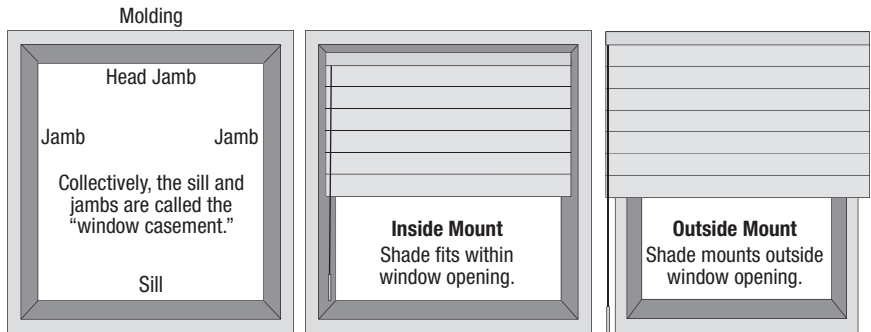

- Refer to the appropriate page below based on your order:
 - **Inside Mount — Page 6**
 - **Outside Mount — Page 7**
 - **End Mount — Page 8**

INSTALLATION

Mount the Installation Brackets — Inside Mount

- Mark 3" from each jamb for bracket location.
- If more than two installation brackets came with your order, space additional bracket(s) evenly between the two end brackets. Mount into wood whenever possible.

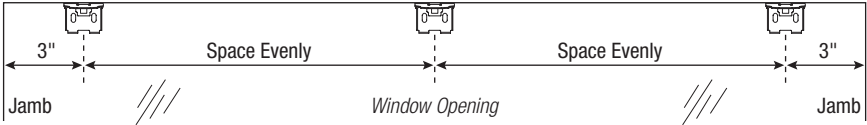

- Center the brackets on your marks and mark each of the screw holes.
- Minimum mounting depth for bracket attachment is 1". Fully recessed mounting depth is $3\frac{7}{8}$ ".

IMPORTANT: The front edges of the installation brackets must be aligned to each other.

- Drill the screw holes using a $\frac{3}{32}$ " drill bit.

CAUTION: Use drywall anchors when mounting into drywall.

- Use a level to check that the mounting surface is level. Shim the brackets if necessary.
- Attach the installation brackets using the screws provided.

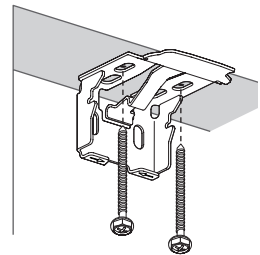
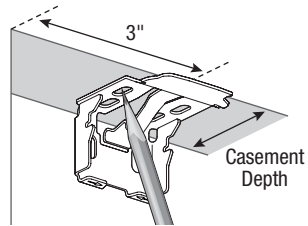

Proceed to "Install the Shade" on page 9.

Mount the Installation Brackets — Outside Mount

- Center the shade over the window opening at the desired height. Use a pencil to lightly mark each end of the headrail on the mounting surface.
 - Alternatively, measure the width of the headrail and use that width to mark the headrail end points over the window opening.
- Mark 3" from each end of the headrail.
 - If more than two installation brackets came with your order, space them evenly between the two end brackets and mark their location. Mount into wood whenever possible.

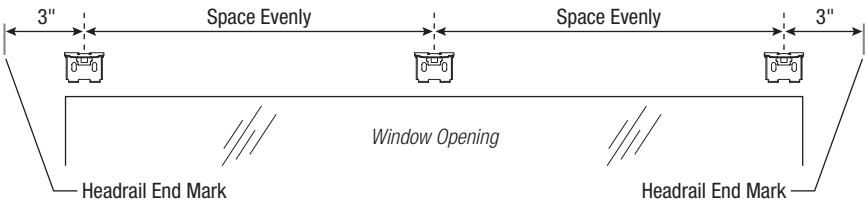

- Center the brackets on your marks and mark each of the screw holes.
 - A minimum 1" flat vertical surface is required to mount the brackets.
 - The top of the installation brackets should be at the desired shade height. The brackets should be level and aligned.

CAUTION: The rear of the brackets must be flush against a flat mounting surface. Do not mount brackets on curved molding.

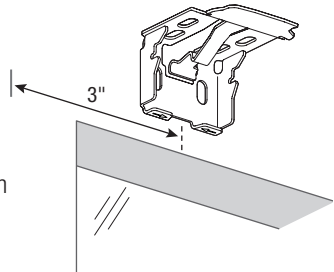

INSTALLATION

- Drill the screw holes using a $\frac{3}{32}$ " drill bit.

CAUTION: Use drywall anchors when mounting into drywall.

- Attach the installation bracket using the screws provided.

IMPORTANT: The front edges of the installation brackets must be level and aligned to each other.

- If using spacer blocks, attach the spacer block(s) and installation bracket to a flat vertical mounting surface with #6 mounting screws long enough for a secure installation.

- A maximum of $1\frac{1}{2}$ " of spacer blocks per installation bracket is recommended.

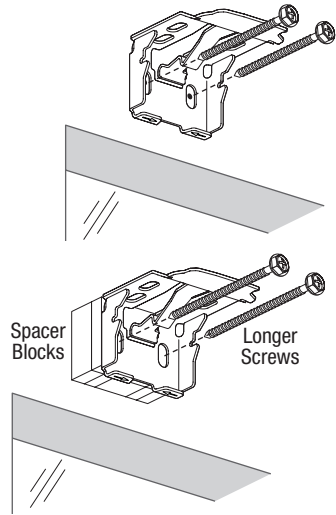

Proceed to "Install the Shade" on page 9.

Mount the Installation Brackets — End Mount

End mount the headrail when conventional mounting techniques will not work — for example, in an arched window.

- Mount the extension brackets on a surface at least $1\frac{1}{2}$ " wide.
- The top of the extension brackets should be at the desired shade height. The brackets should be level and aligned.

CAUTION: The rear of the extension brackets must be flush against a flat mounting surface. Do not mount the extension brackets on the curve of the arch opening.

- Attach the installation brackets to the underside of the extension brackets using the provided screws and speed nuts.

CAUTION: Both brackets must be installed at the same depth and height.

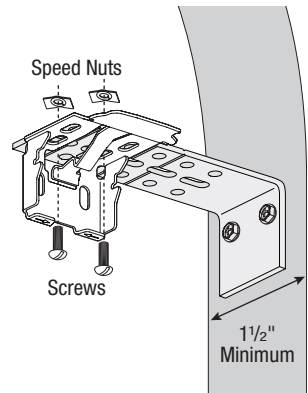

Proceed to "Install the Shade" on page 9.

Install the Shade

- Hold the headrail so the front (curved side) faces you.
- Push the top edge of the headrail into the installation brackets.
- Rotate and push the headrail back until it snaps into place. You will hear a click when the shade is securely installed.



WARNING: Failure to snap the headrail securely into the installation brackets may cause the shade to release unexpectedly.

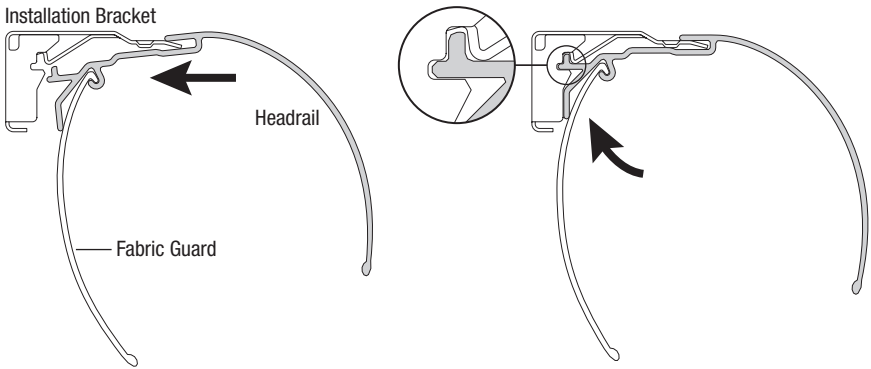

- Gently pull on the front of the headrail to ensure that the shade is locked into the brackets.
- Remove the protective covering on the front of the headrail.

INSTALLATION

Attach the Universal Cord Tensioner — EasyRise™ Shades Only

Before you proceed, you must first slide the cord tensioner(s) to the bottom of the cord loop.

- Insert a small screwdriver, punch, or awl through the screw hole at the bottom of the cord tensioner.
- Move the screw hole down to the indicator line to release the safety mechanism.
- Slide the cord tensioner down to the bottom of the cord loop.
- Attach the cord tensioner(s) according to the instructions provided with the *Universal Cord Tensioner Installation Kit*.

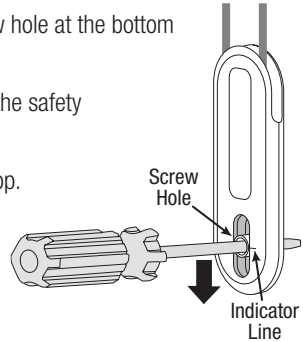

WARNING: It is imperative that the cord tensioner(s) be properly secured to the wall or window frame to reduce children's access to the cord loop. Young children can strangle in cord loops. They can also wrap cords around their necks and strangle.

CAUTION: The shade will not operate properly unless the cord tensioner(s) is secured. A *Universal Cord Tensioner Installation Kit* has been included with your shade. Follow the instructions in the kit to correctly secure the cord tensioner(s).

Cord Adjustment — UltraGlide® Shades Only

Adjusting the tassel to eye level will decrease the amount of pulls needed to raise and lower the shade. This will also enhance child and pet safety.

To Shorten the tassel cord:

- Grasp both parts of the tassel (the colored cover and the frosted body).
- Squeeze the tassel cover with your thumb and forefinger, as shown.
- Separate and slide the tassel cover off from the tassel body.
- Pull out the knotted end of the tassel cord.
- Tie the cord at the desired shorter length, using a double knot.
- Trim the tassel cord below the knot.
- Pull the trimmed knot up inside the tassel.
- Squeeze the tassel cover while sliding it back onto the tassel body.

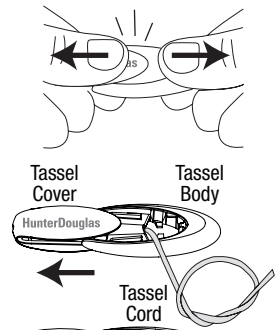

IMPORTANT: After reassembling, be sure that there are no gaps between the two components. Check that they do not pull apart easily. The tassel cover should be securely seated into the tassel body.

Install the Pull Tassel (Optional for LiteRise® Shades Only)

- Rotate the bottom rail so that you can see the underside of the handle.
- Push the pull cord loop through the hole at the back of the handle.
- Thread the pull tassel through the loop.
- Pull the tassel to secure.

OPERATION

Attach the Magnetic Hold-Down Brackets (Optional)

- Lower the shade until it is fully lowered and rotated back toward the window.
- Attach the magnetic hold-down brackets onto the bottom rail just inside the end caps, oriented as shown.
- Mark the screw locations using one of the mounting options shown below.
 - The screw should be placed in the middle of the channel. This will allow for adjustment.

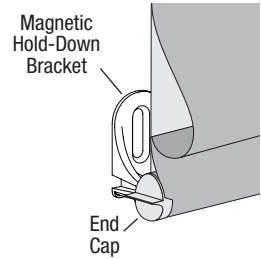

Outside Mount

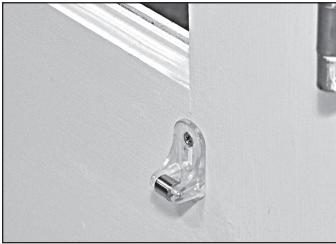

Preferred



Alternate

Inside Mount



Preferred

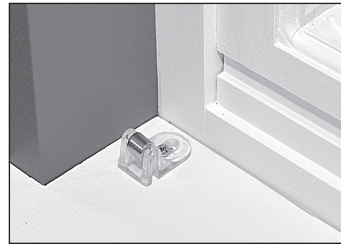

Alternate

- Drill the screw holes using a $\frac{3}{32}$ " drill bit.

CAUTION: Use drywall anchors when mounting into drywall.

- Attach the hold-down brackets to the mounting surface using the screws provided.
- If necessary, adjust the bracket height by loosening the screw and sliding the bracket up or down.

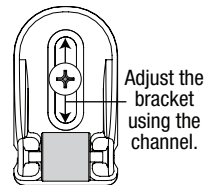

Operate the Shade

EasyRise™ Shades

IMPORTANT: If the cord tensioner moves with the cord, you have not secured it to the wall or window frame. You must do so for the shade to operate properly. See the *Universal Cord Tensioner Installation Instructions* in the kit included with your shade.

To Lower the Shade:

- Pull the front cord of the cord loop to lower the shade from the top. Continue to pull until the shade is fully lowered and rotated back toward the window.

To Raise the Shade:

- Pull the rear cord of the cord loop to raise the shade. Continue to pull the rear cord to raise the shade into the headrail.

Top-Down/Bottom-Up Shades:

- Raise or lower the middle rail by continuing to pull the rear or front cord of the cord loop. The fabric folds will stack at the bottom, when lowered. On inside mount shades, the bottom rail and folds may rest on the sill.

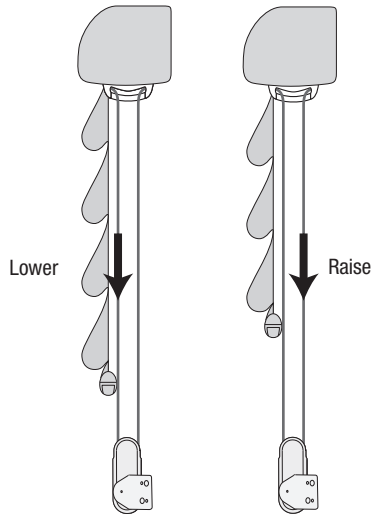

LiteRise® Shades

For better support and smoother operation, use the handle when raising and lowering the shade.

To Lower the Shade:

- Gently pull down on the bottom rail handle. The shade will retract slightly to the desired position.

To Raise the Shade:

- Gently pull down on the handle to engage the shade. Then steadily raise the shade into the headrail or retract the shade to the desired position.

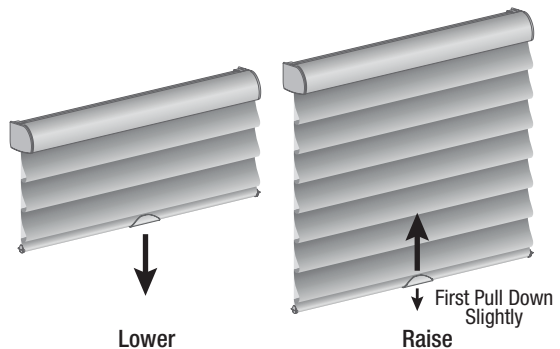

OPERATION

UltraGlide® Shades

CAUTION: To avoid damage to the shade or personal injury, do not let go of the cord until it is fully retracted.

To Lower the Shade:

- Using long, even strokes, pull the cord toward the center of the shade.
- When first lowering from the fully raised position, it may require two or more gentle pulls to release the shade.
- Continue to pull until the shade is fully lowered and the fabric has moved back toward the window.
- To stop the shade at any time, stop pulling the cord and allow it to fully retract.

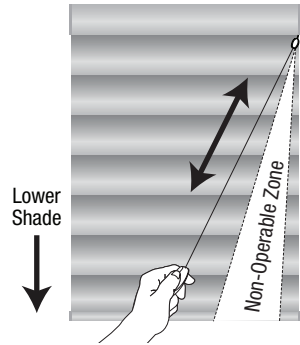

To Raise the Shade:

- Using long, even strokes, pull the cord straight down or to the outside of the shade to raise the bottom rail.
- To stop the shade at any time, stop pulling the cord and allow it to fully retract.

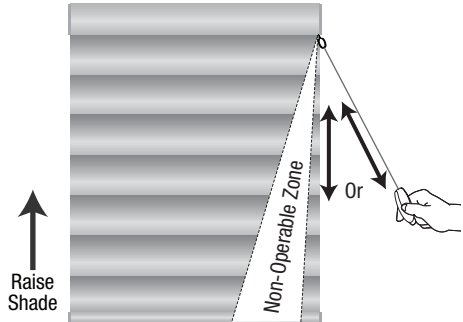

Top-Down/Bottom-Up Shades:

- Raise or lower the middle rail by continuing to pull the cord using long, even strokes. The fabric folds will stack at the bottom, when lowered. On inside mount shades, the bottom rail and folds may rest on the sill.

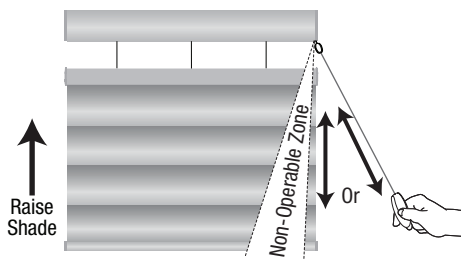
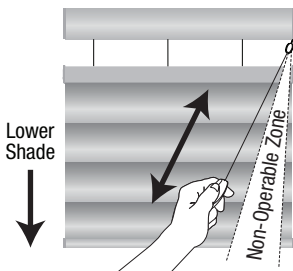

Troubleshooting

Problem	The shade is hard to raise or lower, or will not raise or lower.
Solution	<p>Check that the headrail and installation brackets are level and aligned in the window. Level the headrail by shimming the installation brackets, if necessary.</p> <p>Make sure the fabric is not caught in the installation brackets.</p> <p>EasyRise™ shades: Check that the cord tensioner is mounted correctly. See <i>Universal Cord Tensioner Installation Instructions</i> in the kit included with your shade.</p> <p>EasyRise shades: Check that cord loop is not pinched or tangled.</p> <p>UltraGlide® shades: As you pull the cord, check that the cord is clearing the fabric folds.</p> <p>LiteRise® shades: Pull down on the handle to engage the shade for operation.</p>
Problem	The fabric folds gather unevenly or seem to wrinkle.
Solution	<p>Slowly lower the shade and raise the shade again.</p> <p>NOTE: This is inherent on narrow shades when fully stacked.</p>
Problem	The shade will not snap into the installation brackets.
Solution	<p>Check that the installation brackets are aligned and level. Level the headrail by shimming the installation brackets, if necessary.</p> <p>Check that the headrail is properly aligned in the installation brackets. See “Install the Shade” on page 9.</p> <p>Check that the fabric is not caught in the brackets.</p>
Problem	The front fabric appears to cling to the back fabric.
Solution	Lightly apply a static spray for home furnishings. Follow the manufacturer’s directions. If necessary, reapply the static spray each time the shade is professionally cleaned. Allow the shade to dry in the fully lowered position.

OPERATION

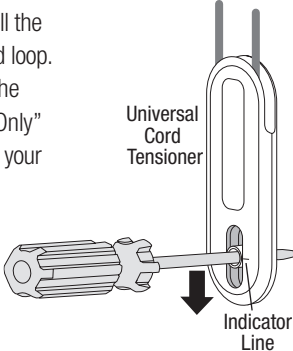
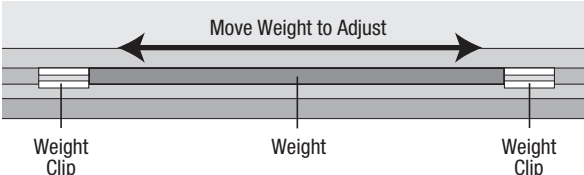
<p>Problem</p>	<p>EasyRise™ shades only: The universal cord tensioner has climbed to the headrail.</p>
<p>Solution</p>	<p>Pull down on the spring to relieve tension and pull the universal cord tensioner to the bottom of the cord loop. Properly mount the cord tensioner. See “Attach the Universal Cord Tensioner — EasyRise Shades Only” on page 10 and/or the instructions included with your <i>Universal Cord Tensioner Installation Kit</i>.</p>  <p style="text-align: right;">Universal Cord Tensioner</p> <p style="text-align: right;">Indicator Line</p>
<p>Problem</p>	<p>EasyRise shades only: Shades raise at different rates when the cord is pulled.</p>
<p>Solution</p>	<p>Depending on the size and weight of the shades, the clutch ratios may be different. More cord travel is required with larger shades than with smaller shades. This is completely normal, and not a defect of the product.</p>
<p>Problem</p>	<p>The shade raises or lowers unevenly, or the bottom rail is uneven when fully raised.</p>
<p>Solution</p>	<p>Check that the headrail is level. Level the headrail by shimming the installation brackets, if necessary.</p> <p>With Top-Down/Bottom-Up Shades only: Check that the top of the fabric (middle rail) is level. Adjust by hand.</p> <p>Adjusting the Bottom Weight:</p> <p>Access the weight on the back of the bottom rail.</p> <p>Push up on the weight clips to release.</p> <p>Slide the weight in 1" increments, toward the side where fabric is gathering.</p>  <p style="text-align: center;">Move Weight to Adjust</p> <p style="text-align: center;">Weight Clip Weight Weight Clip</p> <p>Lower the shade all the way and check that the bottom rail is level. Adjust the weight until the fabric winds evenly and does not gather on either side.</p> <p>After final adjustments, slide the weight clips back into place.</p>

Removing the Shade (If Necessary)

- Fully raise the shade.
- While holding the headrail, place the flat blade screwdriver on the installation bracket's locking tab.
 - Insert the screwdriver between the arrows on the bottom tabs.
- Push up to release the shade.

IMPORTANT: On longer shades, you might need to lower the shade slightly to access the locking tab.

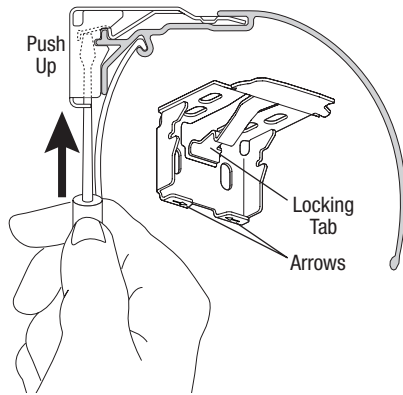

Cleaning Procedures

Vignette® Modern Roman Shades are made of an anti-static, dust-resistant fabric which repels dirt and dust. For most fabrics, the options below are available if your shade needs cleaning.

Dusting

- Regular light dusting with a feather duster is all the cleaning needed in most circumstances.

Vacuuming

- Use a hand-held vacuum with low suction for more thorough dust removal.

Compressed Air / Hair Dryer (Cool Setting)

- Blow dirt and debris from within the fabric folds using clean, compressed air.

Spot-Cleaning

- Prepare a solution of warm water and mild detergent.
- Dampen a clean cloth in the solution and wring it out.
- Place a dry, clean cloth behind the spot between the face fabric and the back fabric.
- Dab the spot with the dampened cloth until it is removed. Non-oil-based baby wipes may be used on more stubborn stains. Do not rub the fabric.
- Allow the shade to dry in the completely lowered position.

CARE

Ultrasonic Cleaning

Vignette® Modern Roman Shades can be ultrasonically cleaned by a professional.

CAUTION: Do not ultrasonically clean the headrail, midrail, bottom rail fabric; or any room-darkening shades.

- Specify that a mild detergent solution be used.
- Never immerse the fabric-covered headrail or bottom rail into the solution.
- Allow the shade to dry in the completely lowered position.

Injection/Extraction Cleaning

Vignette Modern Roman Shades can be cleaned by a professional using the injection/extraction method of deep cleaning.

CAUTION: Do not use the injection/extraction method of deep cleaning on the fabric on the headrail or bottom rail.

- Specify the dry cleaning method only.
- Pretreat heavy stains.

Steaming

CAUTION: Do not steam the fabric on the headrail midrail, or bottom rail.

- Steam the face fabric from the bottom to the top, making sure to get steam under each fabric fold. Be careful not to saturate the fabric with steam.
- Allow the shade to dry completely before raising it.

A Note on Textiles

As with all textiles, Vignette fabrics are subject to some inherent variations in the fabric weave. Subtle dye-lot variations, puckering, or wrinkling fall within textile industry standards and should be considered as normal, acceptable quality. Additionally, there will be slight differences in pattern alignment from the fabric on the rails to the fabric of the shade, which do not detract from the product's appeal.

Variations in color and or pattern are unique characteristics that contribute to the classic beauty of the shade.



WARNING

For more safety information call 1-888-501-8364 in the U.S. or 1-800-225-8000 in Canada.

- Young children can **STRANGLE** in cord loops. They can also wrap cords around their necks and **STRANGLE**.
- Always keep cords out of the reach of children.
- Move cribs, playpens and other furniture away from cords. Children can climb furniture to get to cords.

Cord Loop Shades

- Attach the cord tensioner on the cord loop to the wall or window casement. See “Attach the Universal Cord Tensioner (UCT)” on page 10. This can prevent children from pulling cord loops around their necks.
- Hunter Douglas provides a cord tensioner installation kit with instructions for attaching the cord tensioner. For the shade to operate properly, the cord tensioner must be correctly mounted and secured.
- Fasteners provided in the cord tensioner installation kit may not be appropriate for all mounting surfaces. Use appropriate anchors for the mounting surface conditions.
- Only Hunter Douglas supplied cord tensioners and hardware should be used. Replacement parts may be obtained by contacting the Hunter Douglas Customer Information Center at 1-888-501-8364.

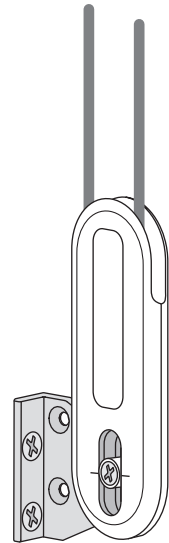

NOTE: The warning labels on corded window coverings contain important safety information. These warning labels are designed to be permanent, in accordance with the industry's safety standards, and must not be removed.

LIFETIME GUARANTEE

The Hunter Douglas® Lifetime Guarantee is an expression of our desire to provide a thoroughly satisfying experience when selecting, purchasing and living with your window fashion products. If you are not thoroughly satisfied, simply contact Hunter Douglas at (888) 501-8364 or visit hunterdouglas.com. In support of this policy of consumer satisfaction, we offer our Lifetime Limited Warranty as described below.

COVERED

BY A LIFETIME LIMITED WARRANTY

- Hunter Douglas window fashion products are covered for defects in materials, workmanship or failure to operate for as long as the original retail purchaser owns the product (unless shorter periods are provided below).
- All internal mechanisms.
- Components and brackets.
- Fabric delamination.
- Operational cords for a full 7 years from the date of purchase.
- Repairs and/or replacements will be made with like or similar parts or products.
- Hunter Douglas motorization components are covered for 5 years from the date of purchase.

NOT COVERED

BY A LIFETIME LIMITED WARRANTY

- Any conditions caused by normal wear and tear.
- Abuse, accidents, misuse or alterations to the product.
- Exposure to the elements (sun damage, wind, water/moisture) and discoloration or fading over time.
- Failure to follow our instructions with respect to measurement, proper installation, cleaning or maintenance.
- Shipping charges, cost of removal and reinstallation.

Hunter Douglas (or its licensed fabricator/distributor) will repair or replace the window fashion product or components found to be defective.

TO OBTAIN WARRANTY SERVICE

1. Contact your original dealer (place of purchase) for warranty assistance.
2. Visit hunterdouglas.com for additional warranty information, frequently asked questions and access to service locations.
3. Contact Hunter Douglas at (888) 501-8364 for technical support, certain parts free of charge, for assistance in obtaining warranty service or for further explanation of our warranty.

NOTE: In no event shall Hunter Douglas or its licensed fabricators/distributors be liable or responsible for incidental or consequential damages or for any other indirect damage, loss, cost or expense. Some states do not allow the exclusion or limitation of incidental or consequential damages, so the above exclusion or limitation may not apply to you. This warranty gives you specific legal rights, and you may also have other rights which vary from state to state.

Different warranty periods and terms apply for commercial products and applications.

HunterDouglas 
hunterdouglas.com

