

HunterDouglas

Installation • Operation • Care

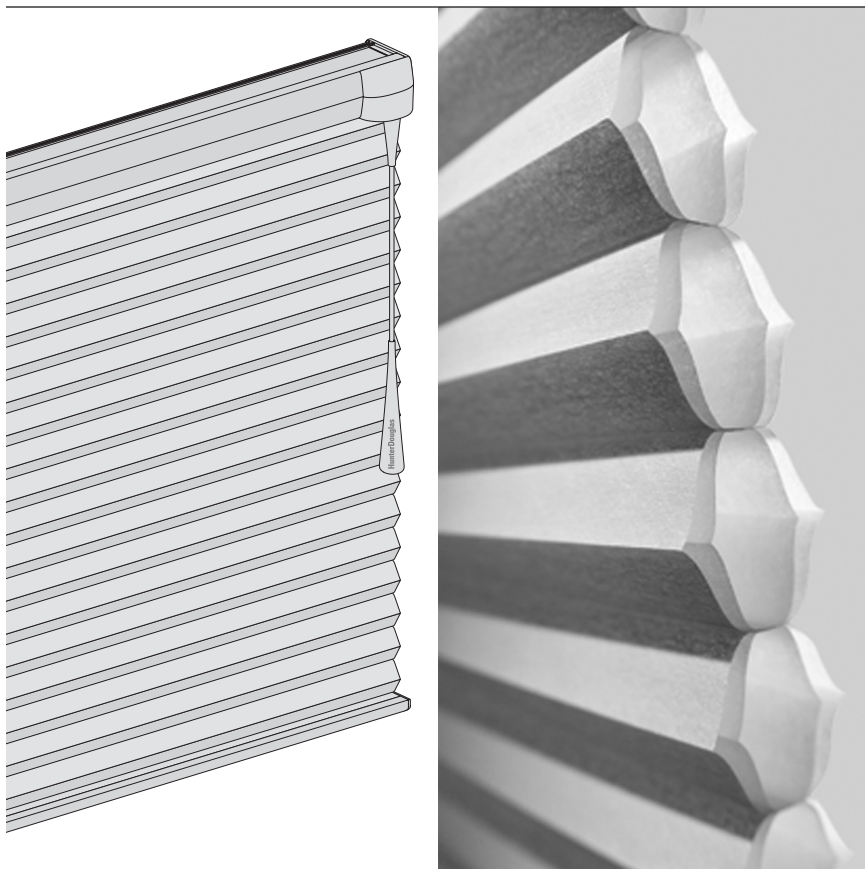

Duette[®] Honeycomb Shades
UltraGlide[®] Lifting System

CONTENTS

Getting Started:

Product View	1
Tools and Fasteners Needed	2

Installation:

Installation Overview	3
Mount the Installation Brackets — Inside Mount	4
Mount the Installation Brackets — Outside Mount	5
Mount the Installation Brackets — End Mount	7
Install the Shade	8
Level the Rail(s), If Necessary.....	9

Operation:

Operate the Shade	10
Troubleshooting	11

Care:

Removing the Shade, If Necessary	12
Cleaning Procedures	12

Child Safety:

Warning	14
---------------	----

Questions?

Call the Hunter Douglas Customer Information Center at
1-888-501-8364.

Product View

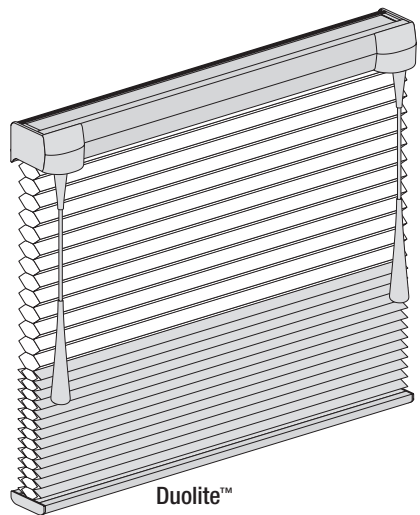
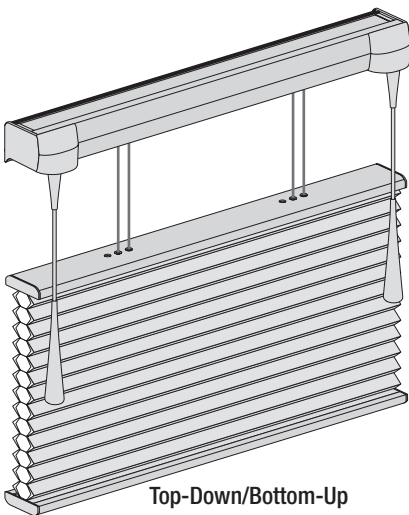
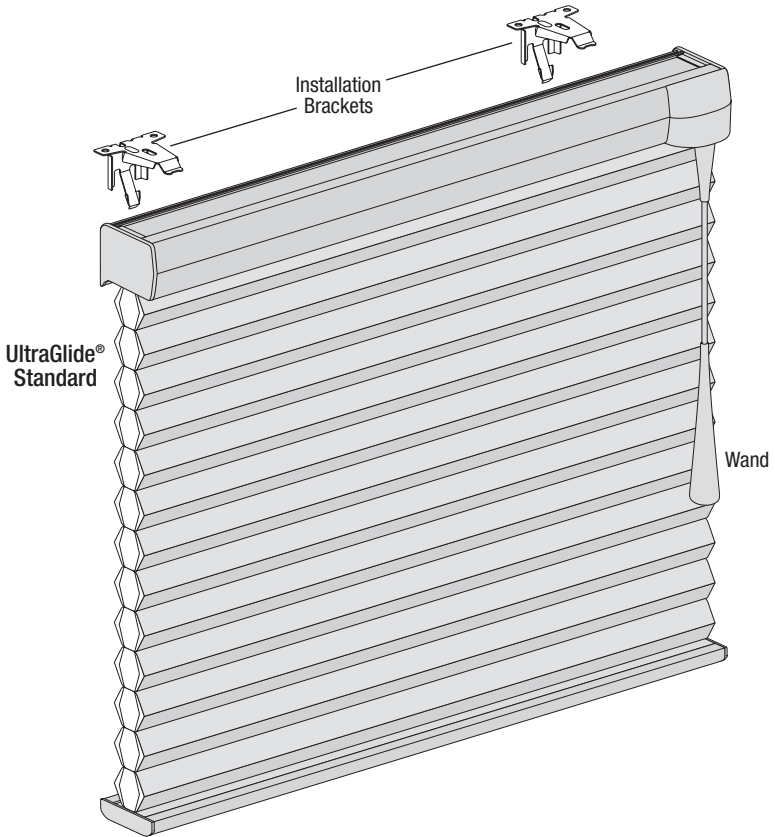

GETTING STARTED

Thank you for purchasing Hunter Douglas Duette® UltraGlide® honeycomb shades. With proper installation, operation, and care, your new shades will provide years of beauty and performance.

Please thoroughly review this instruction booklet and the enclosed packing list before beginning the installation.

Tools and Fasteners Needed

- Flat blade and Phillips screwdrivers
- Level (laser level is recommended)
- Measuring tape and pencil
- Power drill, $\frac{3}{32}$ " drill bit, and $\frac{1}{4}$ " hex driver

In addition, you will need fasteners designed to work with your specific mounting surface(s).

- **#6 Hex Head Screws (Provided).** Two 1 1/2" screws are provided per installation bracket.
- **Longer #6 Hex Head Screws (Not Provided).** If using spacer blocks, use #6 screws long enough for a secure attachment.
- **#6 Flat Head Screws (Provided).** If end mounting the shade, use two 1 1/2" screws per installation bracket.
- **Speed Nuts and Screws (Provided).** Extension brackets come with speed nuts and screws.
- **Drywall Anchors (Not Provided).** Use drywall anchors when mounting into drywall.



#6 x 1 1/2"
Hex Head Screw
(Provided)



Longer #6 Hex Head Screw
for Use with Spacer Blocks
(Not Provided)



#6 Flat Head Screw
for Use with End Mounts
(Provided)



Speed Nut
and Screw
(Provided with Each
Extension Bracket)

Installation Overview

- Your order will include the correct number of installation brackets for your shade width, as shown in the table.
- There are two sizes of installation brackets, one for $\frac{3}{8}$ " and $\frac{3}{4}$ " pleat sizes and a larger one for $1\frac{1}{4}$ " and $1\frac{1}{2}$ " pleat sizes.
- For end mounts, only two brackets are used up to the maximum width of 72".

Shade Width	Brackets Required
12" – 36"	2
36 $\frac{1}{8}$ " – 72"	3
72 $\frac{1}{8}$ " – 108"	4
108 $\frac{1}{8}$ " – 144"	5
144 $\frac{1}{8}$ " – 174"	6

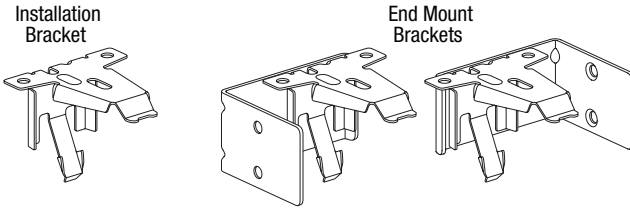

Mounting Types and Window Terminology

If the installation brackets are mounted correctly, the rest of the installation process follows easily. To prepare for this important first step, review the mounting types and basic window terminology illustrated below.

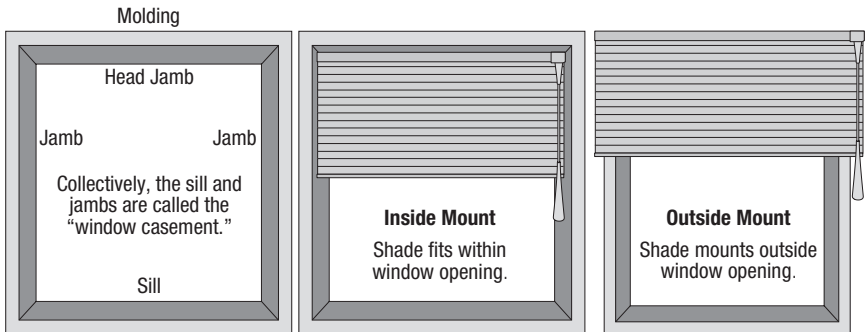

- Refer to the appropriate page below based on your order:
 - **Inside Mount — Page 4**
 - **Outside Mount — Page 5**
 - **End Mount — Page 7**

INSTALLATION

Mount the Installation Brackets — Inside Mount

- Measure 2" from each jamb for bracket location.
 - If more than two installation brackets came with your order, space additional bracket(s) evenly between the two end brackets and mark their location. Mount into wood whenever possible.

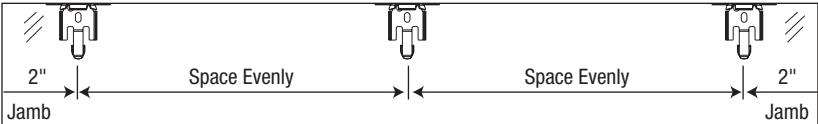

- Center the brackets on your marks, then mark the screw holes.
 - The minimum casement depth for mounting the installation brackets is 1/2". Mark both of the winged screw holes with shallow mounting depths.
 - The minimum casement depth for a fully recessed mount is 2 1/4" for 3/8" and 3/4" pleat sizes; 3" for 1 1/4" pleat size; and 3 1/2" for 1 1/2" pleat size. Mark the center screw hole when depth permits.

IMPORTANT: For 1 1/2" pleat size, a 1/4" rear clearance is recommended.

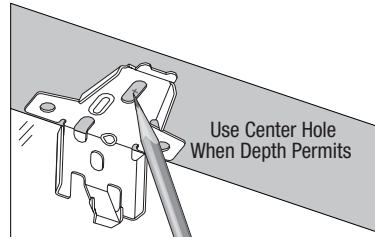
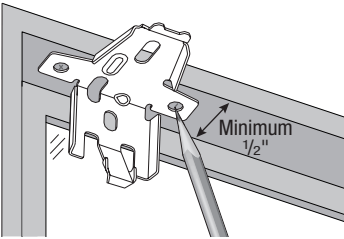

IMPORTANT: The front edges of the brackets must be level and aligned to each other.

- Drill the screw holes using a 3/32" drill bit.
- CAUTION:** Use drywall anchors when mounting into drywall.
- Use a level to check that the mounting surface is level. Shim the brackets if necessary.
- Attach the installation brackets using the screws provided.

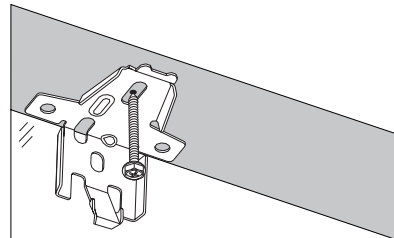
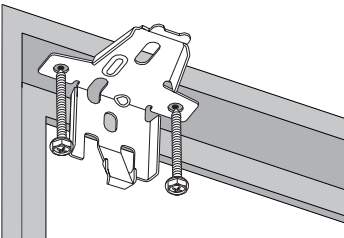

Proceed to "Install the Shade" on page 8.

Mount the Installation Brackets — Outside Mount

- Center the headrail over the window opening at the desired height. Use a pencil to lightly mark each end of the headrail on the mounting surface.
 - Alternatively, measure the width of the headrail and use that width to mark the headrail end points over the window opening.
- Mark 2" from each end of the headrail.
 - If more than two installation brackets came with your order, space additional bracket(s) evenly between the two end brackets and mark their location. Mount into wood whenever possible.

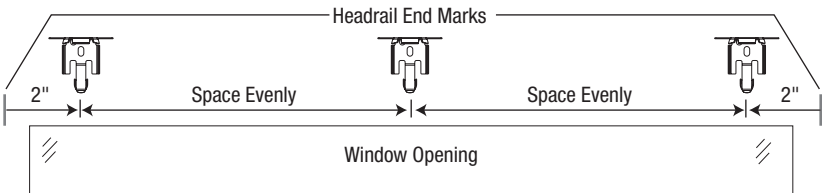

- Center the installation brackets on your marks and mark where to drill the screw holes.
 - A minimum flat vertical surface of 1 1/4" for installation brackets or extension brackets is required.
 - The top of the installation brackets or extension brackets should be at the desired height. The brackets should be level and aligned.
 - When using extension brackets, mark two screw holes per bracket.

CAUTION: The rear of the brackets must be flush against a flat mounting surface. Do not mount brackets on curved molding.

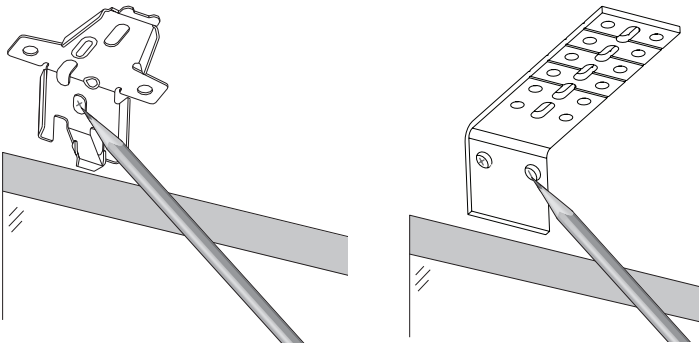

- Drill the screw holes using a 3/32" drill bit.
 - CAUTION:** Use drywall anchors when mounting into drywall.

INSTALLATION

- Attach the installation or extension brackets using the screws provided.

IMPORTANT: The front edges of the brackets must be level and aligned to each other.

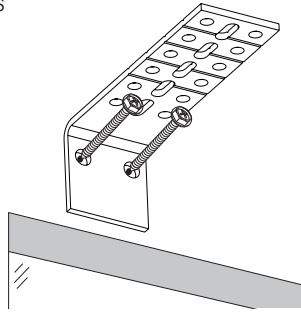
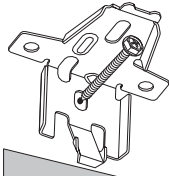

- If using spacer blocks, first attach the installation bracket to the 1/2" spacer block before stacking additional spacer blocks together.

- Insert the legs of the installation bracket into the tabs on the spacer block.
- Then rotate the installation bracket back.

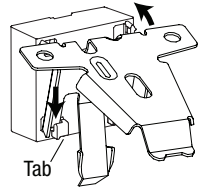

IMPORTANT: For 1 1/2" pleat size a 1/4" rear clearance and a minimum of 1/2" spacer block is recommended.

- Attach the spacer block and installation bracket to a flat vertical mounting surface with a #6 mounting screw long enough for a secure installation.

- A maximum of 1 1/2" of spacer blocks per installation bracket is recommended.
- The top of the spacer blocks should be at the desired shade height.

IMPORTANT: The front edges of the installation brackets must be level and aligned to each other.

CAUTION: Use drywall anchors when mounting into drywall.

- If using extension brackets, attach an installation bracket to the underside of each extension bracket using the provided screws and speed nuts.

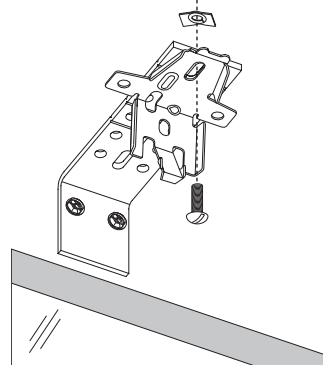
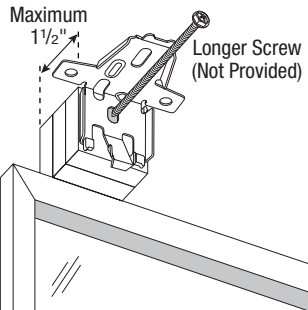

Proceed to "Install the Shade" on page 8.

Mount the Installation Brackets — End Mount

End mount the headrail when conventional mounting techniques will not work — for example, in an arched window opening.

- Position the end mount brackets so that the top of the attached installation brackets are at the ordered height of the shade.

CAUTION: Both brackets must be installed at the same depth and height.

- Mark both screw holes.
 - The mounting surface must be vertical and flat, not part of an arched curve.
 - Minimum mounting depth is 1 1/4" for 3/4" and 3/8" pleat sizes. Minimum mounting depth for a fully recessed end mount is 2 3/8" for 3/4" and 3/8" pleat sizes.
 - Minimum mounting depth is 2" for 1 1/4" and 1 1/2" pleat sizes. Minimum mounting depth for a fully recessed end mount is 3" for 1 1/4" pleat size and 3 1/2" for 1 1/2" pleat size.

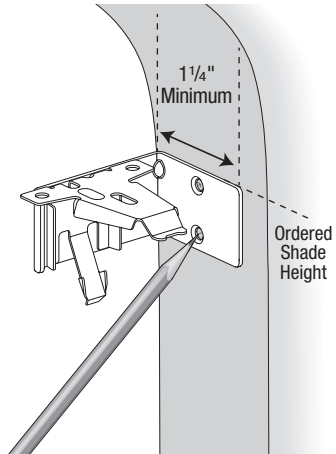

- Drill the screw holes using a 3/32" drill bit.
- Attach the end mount installation brackets using the flat head screws provided.

CAUTION: Drywall mounting is not recommended.

IMPORTANT: For instructions on installing an arch over a rectangular shade, see the Installation, Operation, and Care instructions that came with your arch shade.

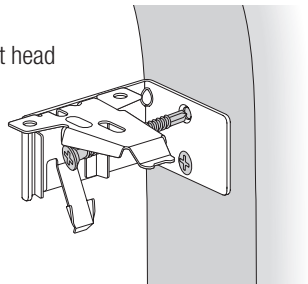

Proceed to "Install the Shade" on page 8.

INSTALLATION

Install the Shade

- Fit the front channel on top of the headrail onto the front lip of the installation brackets.
- Push the headrail up and back until it snaps into place.
- Check to ensure the headrail is securely in the brackets.
 - Check that the bottom of the headrail is snapped into the base of each bracket.
 - Check that the front lip of each bracket is in the front channel of the headrail.
- If any brackets are not installed correctly, release the shade and reinstall. See “Removing the Shade, If Necessary” on page 12.

The front of the bracket fits under the groove.

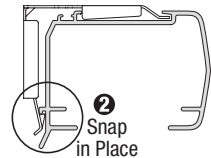
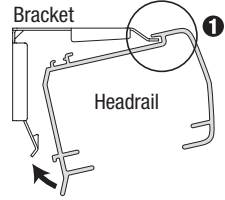

The back of the headrail snaps into the bracket.

Good

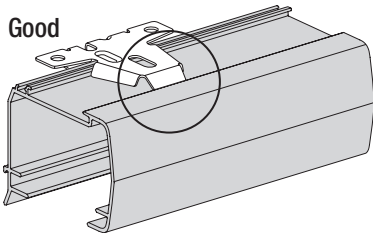

Bad

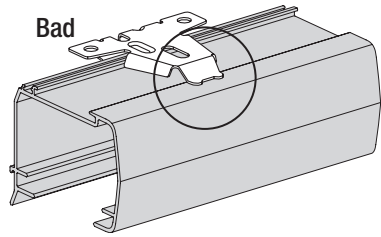

Level the Rail(s), If Necessary

- Lift the bottom rail to locate the pockets on the underside of the rail.
 - With the middle rail on Top-Down/Bottom-Up shades, the pockets are on the top side of the rail.
 - See below for the middle rail adjustment on Duolite™ shades.
- Gently pull down on the bottom rail (or up on the middle rail) to fully insert the $\frac{7}{64}$ " Easy Adjust key into the pocket. The key is fully inserted when the ring on the key abuts to the pocket.
 - Lift up the rail slightly before turning the Easy Adjust key. Turn the key clockwise to raise that side of the rail, or counter-clockwise to lower it.
 - One quarter turn of the key equals approximately $\frac{1}{4}$ ".

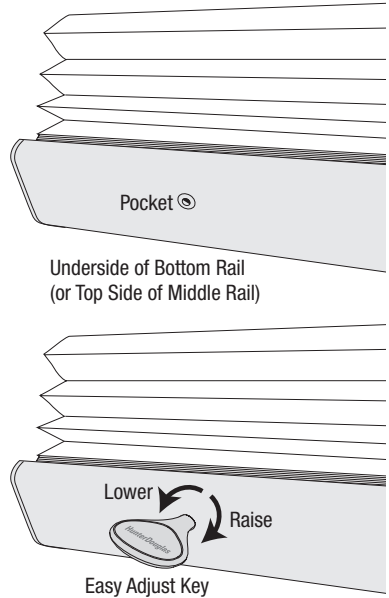

IMPORTANT: The Easy Adjust key must be fully inserted to avoid stripping the mechanism. Do not pull down on the rail while turning the key.

- If there are more than two pockets, adjust the outer pockets first. Then adjust inner pockets as necessary, to maintain equal tension across the rail. As pocket adjustments are made, it is recommended that the shade be raised and lowered to check that it is level.

Adjusting the Duolite Middle Rail

- Hex pockets are found at the ends of the middle rail, which is located in the top cell of the lower fabric panel.
- Insert the Easy Adjust key so that its hex-shaped portion is about halfway into the pocket.
- Turn the key clockwise to raise that end of the rail or counter-clockwise to lower it.
 - One full turn of the key equals approximately $\frac{1}{8}$ ".
- On shades over 60" wide, there will be two hex pockets in the right end of the middle rail. Use the rear hex pocket to adjust the tension in the center cord after adjusting the outer cords to level the rail.

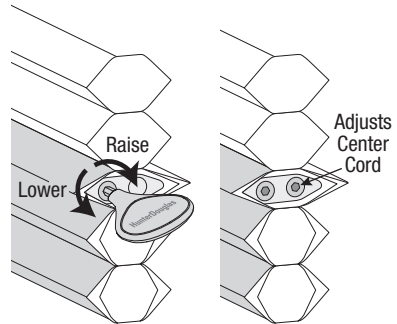

OPERATION

Operate the Shade

For smooth operation, keep the wand close to the fabric when raising and lowering the shade.

To Lower the Shade

- Pull the wand toward the center of the shade at about a 45° angle. The locking mechanism at the top of the wand releases with a “click.” The shade lowers as you allow the wand to return to the vertical position.

IMPORTANT: The wand must be pulled in close to the front of the shade. Do not pull the wand out away from the shade.

- To stop the shade while lowering, move the wand back toward the vertical position and give a slight downward pull to engage the locking mechanism.
- If the shade hits an obstruction as it is lowered it will stop, which may cause the cords in each cord rout to become misaligned. This may cause the shade to be angled or tilted when fully raised. If this occurs, do the following:
 - Raise the shade slightly.
 - Lower the shade completely to the sill. In some cases, pull gently on the bottom rail to get it to drop completely.

IMPORTANT: If the shade is tilted when fully raised, do not pull harder on the wand. It does not correct the tilt and may make it worse.

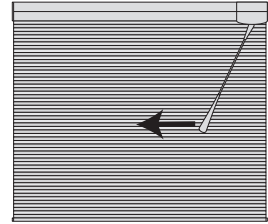

To Lower: Pull the wand toward the center of the shade and release.

To Raise the Shade

- Pull the wand straight down or slightly toward the outside.
 - With each stroke the shade partially raises.
 - Allow the wand to retract after each downward stroke.
 - Use multiple strokes until the shade reaches the desired position.



To Raise: Pull the wand straight down with short strokes.

Duolite™ and Top-Down/Bottom-Up Shades

- To operate Duolite™ and Top-Down/Bottom-Up shades, the right wand operates the middle rail and the left wand operates the bottom rail (unless reverse controls were specified on the order).

IMPORTANT: You must first lower the bottom rail before lowering the middle rail. Likewise, you must first raise the middle rail before raising the bottom rail.

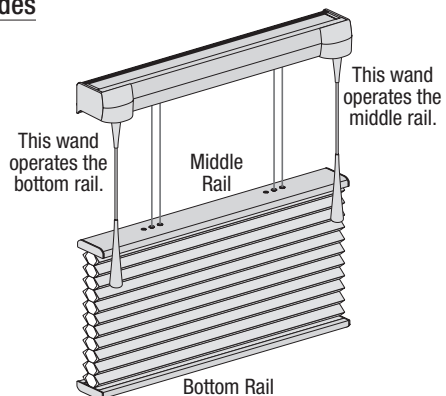

Troubleshooting

Problem	The shade is hard to raise or lower, or will not raise or lower.
Solution	<p>Make sure that the shade fabric is not caught between the installation bracket and the headrail.</p> <p>Check that the headrail and installation brackets are level and aligned. Shim the installation brackets to level the headrail, if necessary.</p>
Problem	The shade raises or lowers unevenly or the bottom rail is uneven when fully raised.
Solution	<p>Check that the headrail and installation brackets are level and aligned. Shim the installation brackets to level the headrail, if necessary.</p> <p>Check to see if there is an obstruction in the shade's path. If the shade hits an obstruction as it is lowered it will stop, but the cords in each cord rout may become misaligned. See "Operate the Shade" on page 10. This may cause the shade to be angled or tilted when fully raised. If this occurs, do the following:</p> <ul style="list-style-type: none"> ➤ Raise the shade slightly. ➤ Lower the shade completely to the sill. In some cases, pull gently on the bottom rail to get it to drop completely. <p>IMPORTANT: If the shade is tilted when fully raised, do not pull harder on the wand. It does not correct the tilt and may make it worse.</p> <p>Adjust the shade. See "Level the Rail(s), If Necessary" on page 9.</p>
Problem	The shade will not fit into the installation brackets.
Solution	<p>Check that the installation brackets are level and aligned. Shim the installation brackets to level the headrail, if necessary.</p> <p>Be sure the heads of the screws are flush against the installation bracket.</p> <p>Check that the headrail is completely inserted into the installation brackets. See "Install the Shade" on page 8.</p>

Removing the Shade, If Necessary

- Lower the shade approximately 4".
- While holding the headrail, push back on the bottom tab of the installation bracket with a flat head screwdriver to release the bottom of the headrail.
- Then roll the back of the headrail down and out from the bracket.

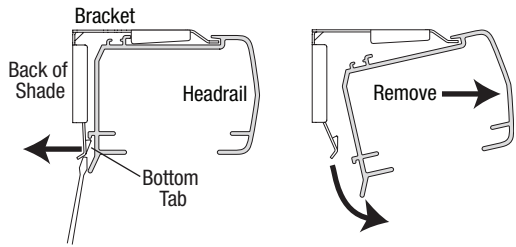

Cleaning Procedures

Hunter Douglas Duette® honeycomb shades are made of anti-static, dust-resistant fabric which repels dirt and dust. For most honeycomb fabrics, the following cleaning options are available.

Dusting

- Regular light dusting with a feather duster is all the cleaning that is needed in most circumstances.

Vacuumping

CAUTION: Do not vacuum Elan®, Trielle™, and Myst™ fabrics.

- For deeper cleaning, vacuum gently with a brush attachment.

Compressed Air/Hair Dryer (Cool Setting)

- Use compressed air or a hair-dryer on a cool setting to blow dust and dirt off shades.

Spot-Cleaning

CAUTION: Do not spot-clean Alexa, Commercial, Elan, India Silk, Jardin, Leela, Macon™, Opalescence™, Trielle, and all Batiste fabrics.

- Prepare a solution of warm water and a mild detergent.
- Dampen a clean cloth in the solution and wring it out.
- Dab the spot with the dampened cloth until it is removed. Do not rub the fabric.
- Allow the shade to dry in the completely lowered position.

Bathtub Cleaning/Water Immersion

CAUTION: Do not immerse Alexa, Commercial, Elan®, India Silk, Northwood™, Panache™, Trielle™, all Batiste fabrics, all Alustra® Duette® fabrics, and all opaque fabrics.

- Immerse the shade in a basin or bathtub filled with warm water and a mild detergent.

IMPORTANT: Never immerse the headrail into the solution.

- Rinse with clean water.
- Before removing from the rinse water, fully raise the shade and tilt it to allow excess water to drain off.
- Dry the shade completely in the lowered position.

Ultrasonic Cleaning

CAUTION: Do not ultrasonically clean Commercial, Myst™, Sheer Opalessence™, and all opaque fabrics.

- Specify that a mild detergent solution be used.

IMPORTANT: Never immerse the headrail into the solution.

- Dry the shade completely in the lowered position.

Injection/Extraction Cleaning

This type of professional cleaning injects a cleaning solution into the fabric and extracts the dirty solution in the same motion.

- Use only the dry method of injection/extraction for Elan and Trielle fabrics.
- If using injection/extraction for Alexa, Batiste Bamboo, and Batiste Textured™ fabrics, specify that no chemicals are used (water only).

Headrail Cleaning

CAUTION: Never use abrasive cleaning methods or harsh chemicals.

- Dampen a soft, clean cloth in warm water and wring it out.
- Gently wipe the headrail to remove dirt and dust.



WARNING

**For more safety information call 1-888-501-8364
in the U.S. or 1-800-265-8000 in Canada.**

Young children can wrap cords around their necks and STRANGLE.

- **Always keep cords out of the reach of children.**
- **Move cribs, playpens and other furniture away from cords. Children can climb furniture to get to cords.**

NOTE: The warning labels on the bottom rails of corded window coverings contain important safety information. These warning labels are designed to be permanent, in accordance with the industry's safety standards, and must not be removed.

LIFETIME GUARANTEE

The Hunter Douglas® Lifetime Guarantee is an expression of our desire to provide a thoroughly satisfying experience when selecting, purchasing and living with your window fashion products. If you are not thoroughly satisfied, simply contact Hunter Douglas at (888) 501-8364 or visit hunterdouglas.com. In support of this policy of consumer satisfaction, we offer our Lifetime Limited Warranty as described below.

COVERED

BY A LIFETIME LIMITED WARRANTY

- Hunter Douglas window fashion products are covered for defects in materials, workmanship or failure to operate for as long as the original retail purchaser owns the product (unless shorter periods are provided below).
- All internal mechanisms.
- Components and brackets.
- Fabric delamination.
- Operational cords for a full 7 years from the date of purchase.
- Repairs and/or replacements will be made with like or similar parts or products.
- Hunter Douglas motorization components are covered for 5 years from the date of purchase.

NOT COVERED

BY A LIFETIME LIMITED WARRANTY

- Any conditions caused by normal wear and tear.
- Abuse, accidents, misuse or alterations to the product.
- Exposure to the elements (sun damage, wind, water/moisture) and discoloration or fading over time.
- Failure to follow our instructions with respect to measurement, proper installation, cleaning or maintenance.
- Shipping charges, cost of removal and reinstallation.

Hunter Douglas (or its licensed fabricator/distributor) will repair or replace the window fashion product or components found to be defective.

TO OBTAIN WARRANTY SERVICE

1. Contact your original dealer (place of purchase) for warranty assistance.
2. Visit hunterdouglas.com for additional warranty information, frequently asked questions and access to service locations.
3. Contact Hunter Douglas at (888) 501-8364 for technical support, certain parts free of charge, for assistance in obtaining warranty service or for further explanation of our warranty.

NOTE: In no event shall Hunter Douglas or its licensed fabricators/distributors be liable or responsible for incidental or consequential damages or for any other indirect damage, loss, cost or expense. Some states do not allow the exclusion or limitation of incidental or consequential damages, so the above exclusion or limitation may not apply to you. This warranty gives you specific legal rights, and you may also have other rights which vary from state to state.

Different warranty periods and terms apply for commercial products and applications.

HunterDouglas 
hunterdouglas.com

