

HunterDouglas

Installation • Operation • Care

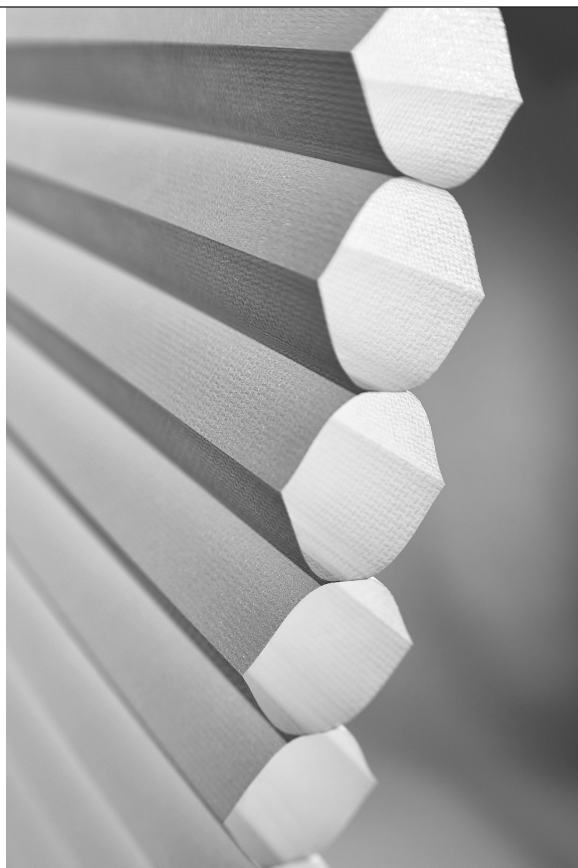
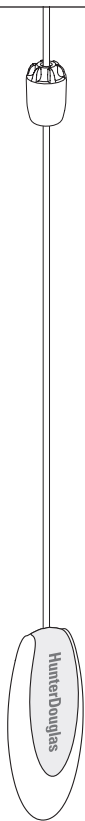

Applause® Honeycomb Shades
Cordlock Operating System

GETTING STARTED

Product View..... 1
Tools and Fasteners Needed 2

INSTALLATION

Installation Overview..... 3
Mount the Installation Brackets — Inside Mount..... 4
Mount the Installation Brackets — Outside Mount 5
Mount the Installation Brackets — End Mount..... 7
Install the Shade..... 8
Attach Hold-Down Brackets (Optional) 8

OPERATION

Operate the Shade..... 9
Troubleshooting 10

CARE

Removing the Shade (If Necessary) 13
Cleaning Procedures 13

CHILD SAFETY

Warning 15

Questions?

Call the Hunter Douglas Customer Information Center at
1-888-501-8364.

PRODUCT VIEW

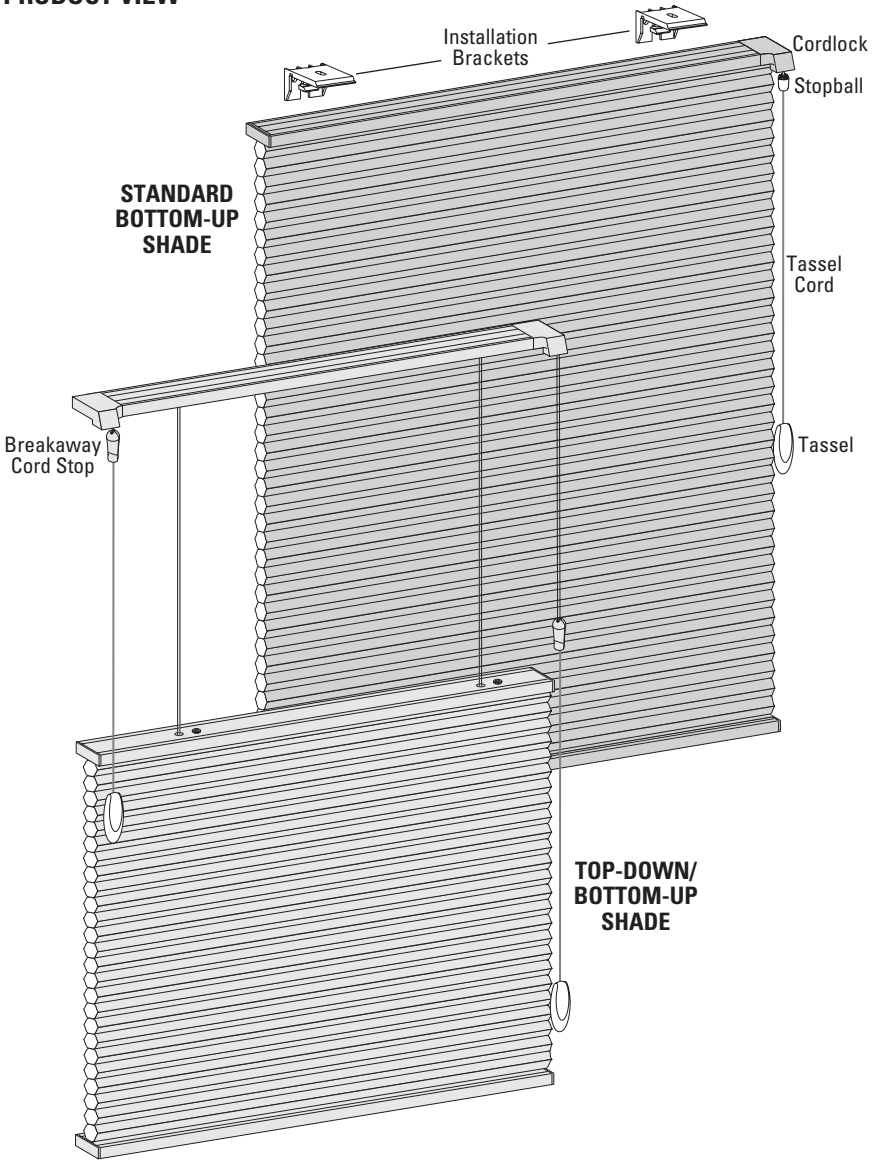

Not Shown: Top-Down, Duolite™, and Two-On-One Headrail Shades

Getting Started

Thank you for purchasing Hunter Douglas Applause® honeycomb shades. With proper installation, operation, and care, your new shades will provide years of beauty and performance.

Please thoroughly review this instruction booklet and the enclosed packing list before beginning the installation. If your shade has a protective plastic cover on the fabric-covered headrail, keep the cover in place until the shade is installed.

TOOLS AND FASTENERS NEEDED

- Flat blade and Phillips screwdrivers
- Level (laser level is recommended)
- Measuring tape and pencil
- Power drill, $\frac{3}{32}$ " drill bit, and $\frac{1}{4}$ " hex driver

In addition, you will need fasteners designed to work with your specific mounting surface(s).

- **#6 Hex Head Screws (Provided).** Two $1\frac{1}{2}$ " screws are provided per installation bracket.
- **Longer #6 Hex Head Screws (Not Provided).** If using spacer blocks, use #6 screws long enough for a secure attachment.
- **Speed Nuts and Screws (Provided).** Extension brackets come with speed nuts and screws.
- **Drywall Anchors (Not Provided).** Use drywall anchors when mounting into drywall.



#6 x $1\frac{1}{2}$ "
Hex Head Screw
(Provided)



Longer #6 Hex Head Screw
for Use with Spacer Blocks
(Not Provided)



Speed Nut
and Screw
(Provided with Each
Extension Bracket)

INSTALLATION OVERVIEW

- Your order will include installation brackets specific to the pleat size and mounting style of your shades.

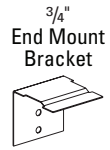
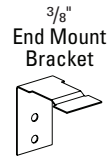
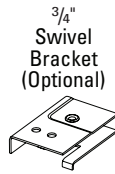
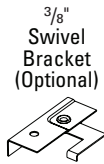
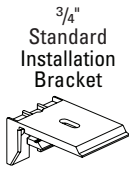
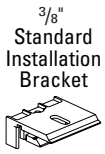

- The number of installation brackets required varies with headrail width, as shown in the table.

Shade Width	Brackets Required
12" – 31"	2
31 $\frac{1}{8}$ " – 79"	3
79 $\frac{1}{8}$ " – 96"	4
96 $\frac{1}{8}$ " – 139"	5
139 $\frac{1}{8}$ " – 174"	6

Mounting Types and Window Terminology

If the installation brackets are mounted correctly, the rest of the installation process follows easily. To prepare for this important first step, review the mounting types and basic window terminology illustrated below.

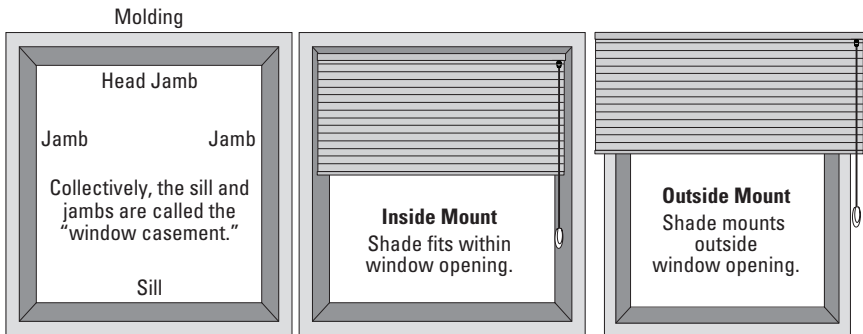

- Refer to the appropriate page below based on your order:

- **Inside Mount — Page 4**
- **Outside Mount — Page 5**
- **End Mount — Page 7**

MOUNT THE INSTALLATION BRACKETS — INSIDE MOUNT

- Mark 3" from each jamb.

- If more than two installation brackets came with your order, space additional bracket(s) evenly between the two end brackets and mark their location. Mount into wood whenever possible.

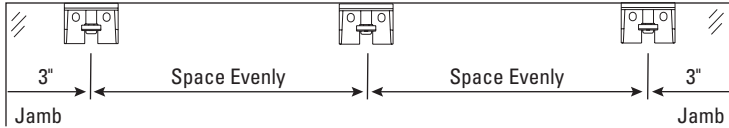

- Center the brackets on your marks and mark the location of the screw holes.

- Mounting depth will vary depending on the fabric pleat size. Refer to the chart for depth requirements.
- For fully recessed mounting, the entire shade is inside the window casement.

Depth Chart For Bracket Placement		
Bracket Type	Minimum	Fully Recessed
3/8" Standard	1"	1 5/8"
3/4" Standard*	1 1/4"	2 3/8"
3/8" Swivel	1/2"	1 1/4"
3/4" Swivel*	1/2"	2"

*Double and triple honeycomb fabrics use 3/4" brackets.

IMPORTANT: The front edges of the installation brackets must be level and aligned.

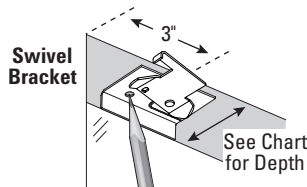
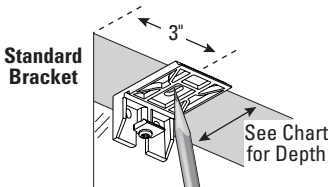

- Drill the screw holes using a 3/32" drill bit.

CAUTION: Use drywall anchors when mounting into drywall.

- Attach the installation brackets using the screws provided.

- Check that the mounting surface is level and the brackets are aligned. If mounting to a heavily textured surface, shim the brackets, if needed.

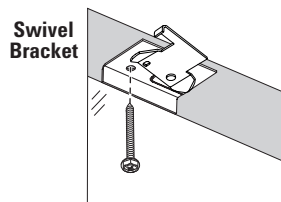
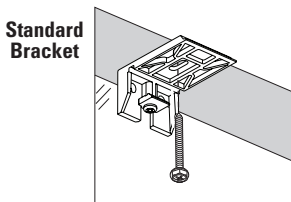

Proceed to "Install the Shade" on page 8.

MOUNT THE INSTALLATION BRACKETS — OUTSIDE MOUNT

- Center the headrail over the window opening at the desired height. Use a pencil to lightly mark each end of the headrail.
 - Alternatively, measure the width of the headrail and use that width to mark the headrail end points over the window opening.
- Mark 3" from each end of the headrail.
 - If more than two installation brackets came with your order, space them evenly between the two end brackets and mark their location. Mount into wood whenever possible.

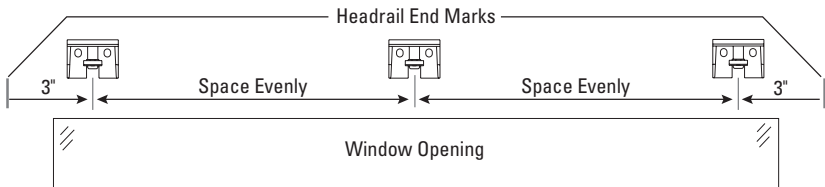

- Center the brackets on your marks, then mark each of the screw holes.
 - A minimum flat vertical surface of $\frac{5}{8}$ " for a $\frac{3}{8}$ " bracket or 1" for a $\frac{3}{4}$ " bracket is required to mount the brackets.
 - The top of the installation brackets or extension brackets should be at the desired shade height.

IMPORTANT: The brackets must be level and aligned to each other.

CAUTION: The rear of the brackets must be flush against a flat mounting surface. Do not mount brackets on curved molding.

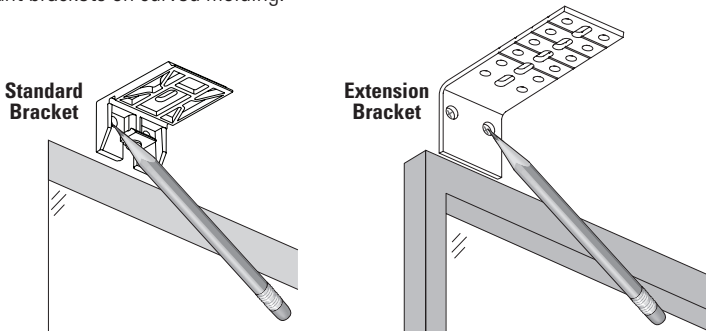

Installation

- Drill the screw holes using a $\frac{3}{32}$ " drill bit.

CAUTION: Use drywall anchors when mounting into drywall.

- Attach the installation brackets or extension brackets using the screws provided.

IMPORTANT: The front edges of the brackets must be level and aligned to each other.

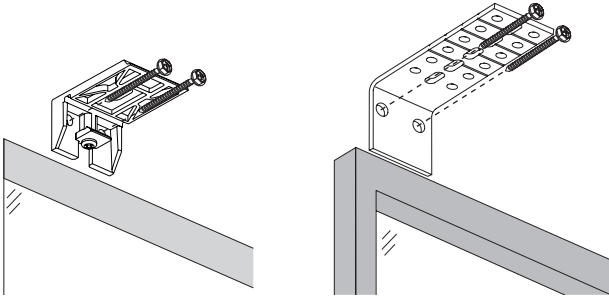

- If using spacer blocks with installation brackets, attach the spacer block(s) and installation bracket to a flat vertical mounting surface with #6 mounting screws long enough for a secure installation.

CAUTION: The rear spacer block must be flush against a flat mounting surface. Do not mount spacer blocks and installation brackets on curved molding.

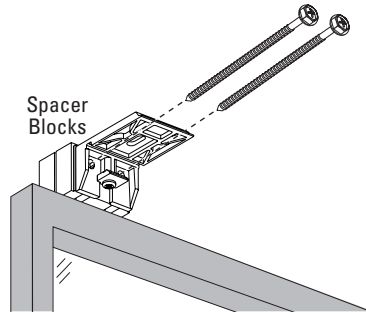

- Each spacer block projects the installation bracket $\frac{1}{2}$ " from the mounting surface. A maximum of $1\frac{1}{2}$ " of spacer blocks per installation bracket is recommended.
- The solid side of the spacer blocks faces the mounting surface.

- If using extension brackets, attach an installation bracket to the underside of each extension bracket using the provided screws and speed nuts.

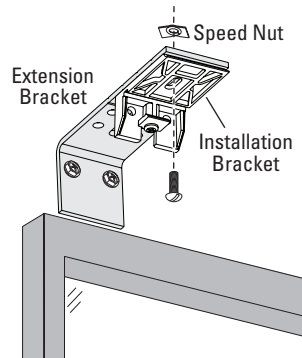

Proceed to "Install the Shade" on page 8.

MOUNT THE INSTALLATION BRACKETS — END MOUNT

End mount the headrail when conventional mounting techniques will not work — for example, in an arched window opening.

Install End Mount Brackets onto the Headrail

- On a headrail end without a cordlock, remove the end cap from the headrail.
- Partially insert the short end of the specialty end mount bracket under the small fabric channels in the headrail.

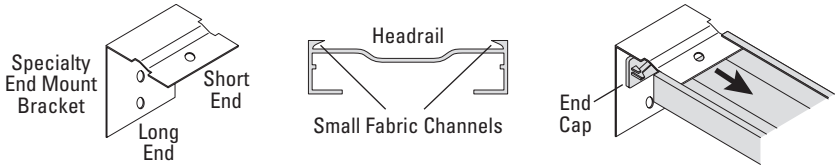

- Replace the end cap and push the bracket and end cap snugly into the headrail.
- To install the bracket on the cordlock side(s), pull the shade cord to the center of the shade to release the lock, as if lowering the shade.
- Pull the cordlock out $\frac{1}{2}$ " and insert the short end of the specialty end mount bracket under the small fabric channels in the headrail.

IMPORTANT: Do not pull the cordlock all the way off the headrail.

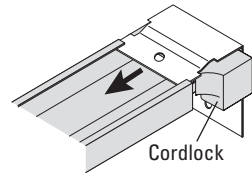

- Push the bracket and cordlock snugly back into the headrail.

IMPORTANT: For instructions on installing an arch over a rectangular shade, see the *Installation, Operation, and Care* instructions that came with your arch shade.

Install the End Mount Brackets to the Window Jamb

- Position the fully lowered shade in the window.
- Gently push the fabric away from the installation bracket to allow access to the screw holes.
- Mark the screw hole locations.

IMPORTANT: Check that the front edges of the shade are level and aligned.

- Remove the shade with the attached end mount brackets from the window.
- Drill the screw holes using a $\frac{3}{32}$ " drill bit.
- Attach the end mount brackets using the screws provided.

Proceed to "Operate the Shade" on page 9.

INSTALL THE SHADE

Standard Brackets

- Position the shade so that the cord faces you.
- Slip the headrail into the installation brackets so the front of the bracket slides under the front groove on the top of the headrail.
- Gently roll the back of the headrail up and push back to snap into place.
- Tighten the tab screw.

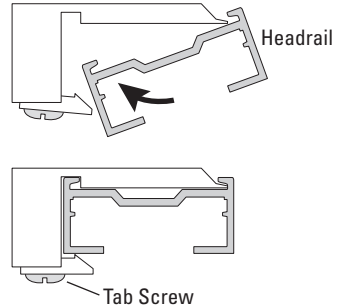

Optional Swivel Brackets

- Place the swivel brackets in the open position.
- Place the headrail against the back of the swivel brackets.
- Rotate the swivel arm to snap the locking tab under the front groove on the top of the headrail.
- The shade is locked when the push tab is against the headrail.

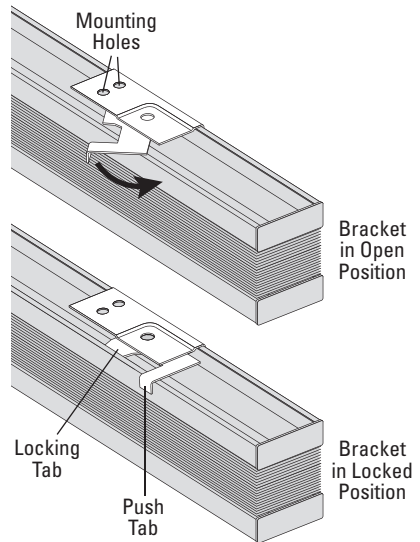

ATTACH HOLD-DOWN BRACKETS (OPTIONAL)

Hold-down brackets are used on outside mounted shades only.

- Lower the shade and place the pins from the hold-down brackets into the bottom rail end caps.
- On the mounting surface, mark the screw holes.
- Check that the brackets are level and aligned, and attach them using two screws.

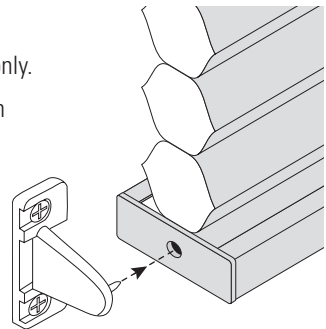

OPERATE THE SHADE

IMPORTANT: Bottom-Up and Top-Down shades have one operating cord. Top-Down/Bottom-Up, Duolite™, and Two-On-One Headrail shades have two operating cords.

- Keep the cord close to the fabric when operating the shade.
- To raise or lower the shade, disengage the cordlock by moving the cord toward the center of the shade.
- Pull on the cord to raise the shade.
- Engage the cordlock by returning the cord to the original position.

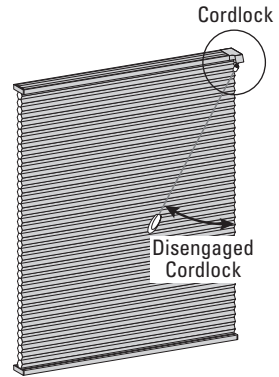

Top-Down/Bottom-Up and Duolite Shades

- To operate Top-Down/Bottom-Up and Duolite shades, the right cord operates the middle rail and the left cord operates the bottom rail (unless specified differently on the order).

IMPORTANT: You must first lower the bottom rail before lowering the middle rail. Likewise, you must first raise the middle rail before raising the bottom rail.

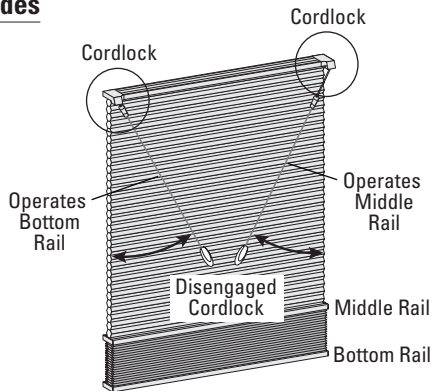

TROUBLESHOOTING

Problem	The shade will not fit into the installation brackets.
Solution	<p>Check that the installation brackets are level and aligned. Shim the installation brackets to level the headrail, if necessary.</p> <p>Be sure the heads of the screws are flush against the installation bracket.</p> <p>Check that the headrail is completely inserted into the installation brackets. See "Install the Shade" on page 8.</p>
Problem	The shade is hard to raise or lower, or will not raise or lower.
Solution	<p>Make sure that the shade fabric is not caught between the installation bracket and the headrail.</p> <p>Check that the headrail and installation brackets are level and aligned in the window. Shim the installation brackets to level the headrail, if necessary.</p> <p>If hold-down brackets are used, make sure they have been released before operating the shade.</p>
Problem	The shade raises or lowers unevenly, or the bottom rail is uneven when fully raised.
Solution	<p>Check that the headrail and installation brackets are level and aligned. Shim the installation brackets to level the headrail, if necessary.</p> <p>Check to see if there is an obstruction in the shade's path. If a shade hits an obstruction as it is lowered, it may become misaligned. This may cause the shade to be angled or tilted when fully raised. Try lowering the shade completely, then raising it to allow it to self-correct.</p> <p>Adjust the shade height. See "Shade Height Adjustment" on page 11.</p>
Problem	The shade will not stay in the raised position.
Solution	To lock the shade in the raised position (or anywhere along the path to the fully raised position), engage the cordlock by pulling the cord toward the outside of the shade.

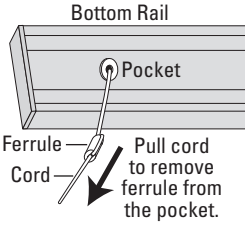
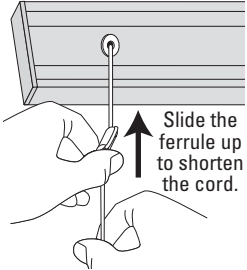
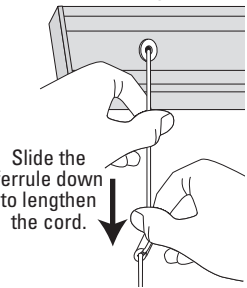
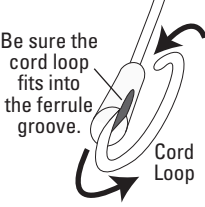
<p>Problem</p>	<p>The bottom rail is not level, or the shade height is incorrect.</p>
<p>Solution</p>	<p>Shade Height Adjustment</p> <p>Shade height and adjustments to level the bottom rail can be made by adjusting the cord on the underside of the bottom rail.</p> <ul style="list-style-type: none"> ■ Locate the ferrule seated in a pocket in the bottom rail. ■ Remove the ferrule from the pocket by pulling on the excess cord. If the cord has been trimmed, pull with needlenose pliers. ■ To shorten the cord, hold the cord tight under the ferrule. Then slide the ferrule up toward the pocket. ■ To lengthen the cord, hold the cord tight between the pocket and the ferrule. Then slide the ferrule away from the pocket. ■ After adjusting, place the ferrule fully back into the pocket. ■ Once you are certain of the final adjustments, tape the extra cord length to the bottom rail or place into the groove on the bottom rail for future adjustments. <div style="text-align: right;">  <p>Bottom Rail</p> <p>Ferrule Cord</p> <p>Pocket</p> <p>Pull cord to remove ferrule from the pocket.</p> <p>To Shorten</p>  <p>Slide the ferrule up to shorten the cord.</p> <p>To Lengthen</p>  <p>Slide the ferrule down to lengthen the cord.</p> </div>
<p>Problem</p>	<p>The ferrule has come off the cord. How do I rethread the ferrule?</p>
<p>Solution</p>	<p>Thread the end of the cord into the tapered end of the ferrule. Loop the cord around the ferrule and back through the tapered end. Make sure the loop fits into the groove on the side of the ferrule.</p> <div style="text-align: right;">  <p>Be sure the cord loop fits into the ferrule groove.</p> <p>Cord Loop</p> </div>

<p>Problem</p>	<p>The tassel cord is too long.</p>
<p>Solution</p>	<p>The tassel cord length is usually two-thirds the length of the fully lowered shade.</p> <p>To Shorten the Tassel Cord</p> <ul style="list-style-type: none"> ■ Grasp both parts of the tassel (the colored cover and the frosted body). ■ Squeeze the tassel cover with your thumb and forefinger, as shown. ■ Separate and slide the tassel cover off from the tassel body. ■ Pull out the knotted end of the tassel cord. ■ Retie the cord at the desired shorter length, using a double knot. ■ Trim the tassel cord. ■ Pull the trimmed knot up inside the tassel. ■ Squeeze the sides of the tassel cover together while sliding it back onto the tassel body. <p>IMPORTANT: After reassembling, be sure there are no gaps between the two components. Check that they do not pull apart easily. The tassel cover should be securely seated into the tassel body.</p>

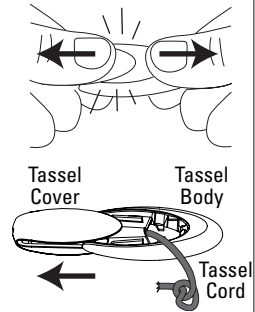

REMOVING THE SHADE (IF NECESSARY)

Standard Brackets

- Fully raise the shade.
- While holding the headrail, loosen the tab screw on each bracket to release the headrail.

Optional Swivel Brackets

- Fully raise the shade.
- While holding the headrail, pull the push tab to rotate the swivel arm to the open position to release the headrail.

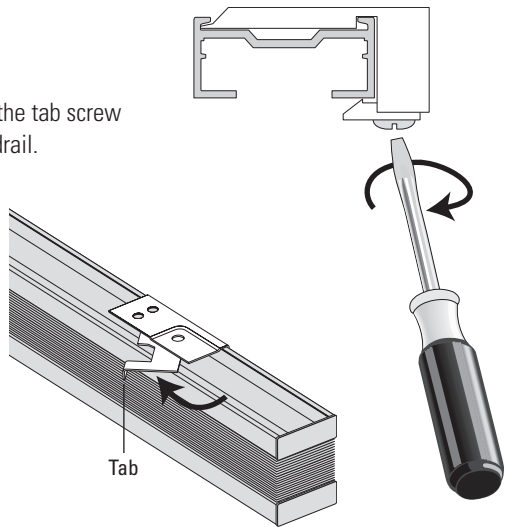

CLEANING PROCEDURES

Hunter Douglas Applause® honeycomb shades are made of anti-static, dust-resistant fabric which repels dirt and dust. For most fabrics, the following cleaning options are available.

Dusting

- Regular light dusting with a feather duster is all the cleaning that is needed in most circumstances.

Vacuuming

- For deeper cleaning, vacuum gently with a brush attachment.

Compressed Air/Hair Dryer (Cool Setting)

- Use compressed air or a hair-dryer on a cool setting to blow dust and dirt off shades.

Spot-Cleaning

- Prepare a solution of warm water and a mild detergent.
- Dampen a clean cloth in the solution and wring it out.
- Dab the spot with the dampened cloth until it is removed. Do not rub the fabric.
- Allow the shade to dry in the completely closed position.

Bathtub Cleaning/Water Immersion

CAUTION: Do not immerse Venue™ and opaque fabrics.

- Immerse the shade in a basin or bathtub filled with warm water and a mild detergent.

IMPORTANT: Never immerse the headrail into the solution.

- Rinse with clean water.
- Before removing from the rinse water, fully raise the shade and tilt it to allow excess water to drain off.
- Dry the shade completely in the closed position.

Ultrasonic Cleaning

CAUTION: Do not ultrasonically clean opaque fabrics.

- Specify that a mild detergent solution be used.

IMPORTANT: Never immerse the headrail into the solution.

- Dry the shade completely in the closed position.

Injection/Extraction Cleaning

This type of professional cleaning injects a cleaning solution into the fabric and extracts the dirty solution in the same motion.



WARNING

For more safety information call 1-888-501-8364 in the U.S. or 1-800-265-8000 in Canada.

Young children can wrap cords around their necks and STRANGLE.

- Always keep cords out of the reach of children.
- Move cribs, playpens and other furniture away from cords. Children can climb furniture to get to cords.
- Do not tie cords together. Make sure cords do not twist together and create a loop.

Cord Cleats

Hunter Douglas provides cord cleats and we recommend their use.

- Attach two cord cleats 6" to 12" apart at a height where they will be out of the reach of children. Take into account that a child may stand on furniture attempting to reach the cords. Be sure the cleats are firmly secured. Once the cleats are attached, wrap excess cord around them after each use of the shade.



Breakaway Cord Stop

To further reduce the hazards of entanglement and strangulation, breakaway cord stops are provided with Honeycomb Top-Down/Bottom-Up and Duolite™ shades. They are designed to break apart when force is applied from the top.

IMPORTANT: Should the breakaway cord stop break apart, be sure to untangle the cords prior to reassembling.

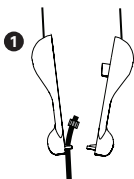

Breakaway
Cord Stop

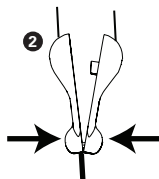

Fit the bottom
edges together.

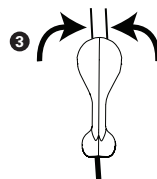

Swing the top
edges together
and snap closed.

NOTE: The warning labels on the bottom rails of corded window coverings contain important safety information. These warning labels are designed to be permanent, in accordance with the industry's safety standards, and must not be removed.

LIFETIME GUARANTEE

The Hunter Douglas® Lifetime Guarantee is an expression of our desire to provide a thoroughly satisfying experience when selecting, purchasing and living with your window fashion products. If you are not thoroughly satisfied, simply contact Hunter Douglas at (888) 501-8364 or visit hunterdouglas.com. In support of this policy of consumer satisfaction, we offer our Lifetime Limited Warranty as described below.

COVERED

BY A LIFETIME LIMITED WARRANTY

- Hunter Douglas window fashion products are covered for defects in materials, workmanship or failure to operate for as long as the original retail purchaser owns the product (unless shorter periods are provided below).
- All internal mechanisms.
- Components and brackets.
- Fabric delamination.
- Operational cords for a full 7 years from the date of purchase.
- Repairs and/or replacements will be made with like or similar parts or products.
- Hunter Douglas motorization components are covered for 5 years from the date of purchase.

Hunter Douglas (or its licensed fabricator/distributor) will repair or replace the window fashion product or components found to be defective.

NOT COVERED

BY A LIFETIME LIMITED WARRANTY

- Any conditions caused by normal wear and tear.
- Abuse, accidents, misuse or alterations to the product.
- Exposure to the elements (sun damage, wind, water/moisture) and discoloration or fading over time.
- Failure to follow our instructions with respect to measurement, proper installation, cleaning or maintenance.
- Shipping charges, cost of removal and reinstallation.

TO OBTAIN WARRANTY SERVICE

1. Contact your original dealer (place of purchase) for warranty assistance.
2. Visit hunterdouglas.com for additional warranty information, frequently asked questions and access to service locations.
3. Contact Hunter Douglas at (888) 501-8364 for technical support, certain parts free of charge, for assistance in obtaining warranty service or for further explanation of our warranty.

NOTE: In no event shall Hunter Douglas or its licensed fabricators/distributors be liable or responsible for incidental or consequential damages or for any other indirect damage, loss, cost or expense. Some states do not allow the exclusion or limitation of incidental or consequential damages, so the above exclusion or limitation may not apply to you. This warranty gives you specific legal rights, and you may also have other rights which vary from state to state.

Different warranty periods and terms apply for commercial products and applications.

HunterDouglas

hunterdouglas.com

