



UltraGas[®]
Condensing Gas Boiler

Hoval

Technical Data
Output range 15 to 2000 kW

4212948/01 - 05/14

Subject to modifications

Description

The Hoval UltraGas® condensing boiler range features many innovative construction details which ensure market-leading efficiency and cost effective heating performance.

Hoval aluFer® technology

The internationally patented aluFer® tube is a Hoval innovation in advanced heat transfer technology. It is constructed from an inner aluminium finned surface, heat shrunk within an outer stainless steel tube. The exceptional efficiency of the heat transfer is attributed to the following factors:

- High heat conductivity of aluminium being ten times greater than that of steel
- A ten times larger heat exchange surface due to the internal finned surface of the aluminium tube
- Optimised turbulence and heat exchange efficiency created by the multiple flow channels on the inner surface of the tube

Sophisticated management for your heating system

The TopTronic® control is the brain of every Hoval system. Innovative microprocessor technology ensures smooth and continuously monitored operation. The LCD display provides information on operating data, while a single rotary push button and seven keys are used to activate heating programs and settings.

If manual intervention is necessary, the required program can be easily found in the self-explanatory user guide.

Record level of efficiency of more than 109%

Low temperature boilers convert about 93% of the calorific value of gas into usable heat. With the UltraGas®, this limit is raised considerably by using condensing technology. One of the main products of combustion gases is water (as steam) and in the conventional boiler the heat within this is lost through the flue. This is not the case with the UltraGas®; in condensing operation the hot steam is cooled back down to 40-50°C thus releasing the latent heat of vapourisation for use in the heating system. The result is as much as a 15% increase in the amount of usable heat which dramatically increases the boiler efficiency.

NOx emissions of less than 40 mg/kWh:

Following additional recent extensive independent emissions testing to DIN EN 676 it is stated by GWI (GasWarme Institut e.V.) that all UltraGas® boilers have average NOx emissions of less than 40 mg/kWh. All figures are dry and at 0% excess oxygen.

The UltraClean® combustion system:

The UltraGas® has uniquely low nitrogen oxide and carbon monoxide emission values. The secret of low emission combustion lies in the specially designed and patented UltraClean® radiation burner and in the gas/air mixture. On the surface of the UltraClean® combustion cylinder, there is an almost flame-free combustion of the gas-air mixture. The low, flat flame pattern remains "cooler" than the gas flames in conventional combustion technology. In this way, substantially lower nitrogen oxide and carbon monoxide emission values can be achieved and as a result the environment is spared a significant amount of harmful waste gases. Natural gas or propane can be used on all models of UltraGas®.

Optimised stratification with separate high and low temperature returns

A key feature of the boiler is that it has two return connections, one directly into the boiler and one into the aluFer® condensing heat exchanger. This stepped heat transfer between the high and low temperature return flows means a lower consumption of fuel. Additionally, the low temperature return need only be as small as 5% of the total, thus the designer can optimise the potential for condensing. No minimum flow rate is required other than at startup and pump overrun.

Twin UltraGas® units are also available

Single UltraGas® condensing boilers are available in a range of twenty one sizes with outputs ranging between 15 and 1000 kW. For larger outputs or if multiple boilers are required, the UltraGas® can be provided as a twin boiler system. This gives a further fourteen sizes with outputs ranging between 250 and 2000 kW.

The twin units are supplied as standard with a flue header.

To enhance the standard twin unit, optional items are available:

- Flow header with motorised shut off valves. A return header can be used if the motorised valves are not required.
- High temperature return header.
- Low temperature return header.

Fine gas filter

An optional fine gas filter is available to provide long term protection to the UltraGas® boiler against dirt ingress via the gas supply. This filter is provided as standard with UltraGas® 400-1000 and 800D-2000D boilers for fitting by the installer adjacent to each of these boilers. Two filters are supplied with twin boiler models to be fitted to individual gas connections.

Technical Data

UltraGas® (15-27)

Type		(15)	(20)	(27)
• Nominal output 80/ 60 °C with natural gas	kW	3.0 - 14.3	3.8 - 18.7	4.5 - 25.0
• Nominal output 40/ 30 °C with natural gas	kW	3.3 - 15.5	4.3 - 20.3	5.0 - 27.2
• Nominal output 80/ 60 °C with liquid gas ¹	kW	4.5 - 13.8	4.9 - 18.6	6.6 - 24.3
• Nominal output 40/ 30 °C with liquid gas ¹	kW	5.0 - 15.3	5.5 - 20.7	7.3 - 27.0
• Nominal load with natural gas	kW	3.1 - 14.5	4.0 - 19.0	4.7 - 25.4
• Nominal load with liquid gas ¹	kW	4.7 - 14.3	5.1 - 19.3	6.8 - 25.2
• Working pressure heating max./min. ²	bar	3.0 / 1.2	3.0 / 1.2	3.0 / 1.2
• Working temperature max.	°C	85	85	85
• Boiler water capacity	l	57	55	51
• Min. water flow rate ³	l/h	0	0	0
• Boiler weight (without water, incl. casing)	kg	131	135	143
• Boiler efficiency according to EN 303 Partial load 30% (related to net / gross calorific value)	%	107.9 / 97.2	108.0 / 97.3	108.0 / 97.3
• Standard efficiency (related to net / gross calorific value) 40/ 30 °C	%	109.5 / 98.6	109.5 / 98.6	109.5 / 98.6
• Standard efficiency (related to net / gross calorific value) 75/ 60 °C	%	107.0 / 96.4	107.0 / 96.4	107.0 / 96.4
• Heat-loss rate at 70 °C	Watt	160	160	160
• Standard emission rate Nitrogen oxides ⁴	mg/kWh	37	37	35
• Standard emission rate Carbon monoxide	mg/kWh	11	11	10
• Content of CO ₂ in the exhaust gas max./min. output	%	9.0 / 8.8	9.0 / 8.8	9.0 / 8.8
• Dimensions	See table of dimensions			
• Connections	Flow/Return	Inches	R1"	R1"
	Gas	Inches	R¾"	R¾"
	Flue gas/combustion air	Ø mm	E80	E80
• Gas flow pressure min./max. Natural gas E	mbar	15-50	15-50	15-50
• Gas flow pressure min./max. Liquid gas ¹	mbar	37-50	37-50	37-50
• Gas connection value at 0 °C / 1013 mbar: Natural gas E - (Wo = 15,0 kWh/m ³) H _u = 9,97 kWh/m ³	m ³ /h	1.5	1.9	2.6
• Gas connection value at 0 °C / 1013 mbar: Propane gas (H _u = 25,9 kWh/m ³)	m ³ /h	0.6	0.8	1.0
• Operation voltage	V/Hz	230/50	230/50	230/50
• Control voltage	V/Hz	24/50	24/50	24/50
• Min./max. electrical power consumption	Watt	24/46	24/64	24/58
• Stand-by electrical consumption	Watt	12	12	12
• IP rating (integral protection)	IP	20	20	20
• Acoustic power level	dB(A)	57	61	66
• Acoustic pressure level at 1 metre	dB(A)	50	56	59
• Condensate quantity (natural gas) at 40/ 30 °C	l/h	1.3	1.8	2.4
• pH value of the condensate	pH	ca. 4.2	ca. 4.2	ca. 4.2
• Values for flue calculation:				
• Temperature class		T120	T120	T120
• Flue gas mass flow	kg/h	23	31	42
• Flue gas temperature with operating conditions 80/ 60 °C	°C	62	63	64
• Flue gas temperature with operating conditions 40/ 30 °C	°C	45	45	45
• Volume flow rate combustion air	Nm ³ /h	17	23	31
• Usable overpressure for air duct/flue system	Pa	100	100	100

¹ UltraGas® (15-27) can also be operated with propane/butane (liquid gas) mixtures.

² Boiler test pressure is 1.5 times max. operating pressure.

³ Although generally the UltraGas boilers do not require a minimum water flow, it does not mean that the pump and burner can be switched off together when the unit is operating at full output. There should be a pump overrun to dissipate any residual heat within the boiler to avoid nuisance high temperature lockouts.

⁴ NOx emissions to EN676 are dry and at 0% excess oxygen

• Boiler flow resistance see diagram opposite

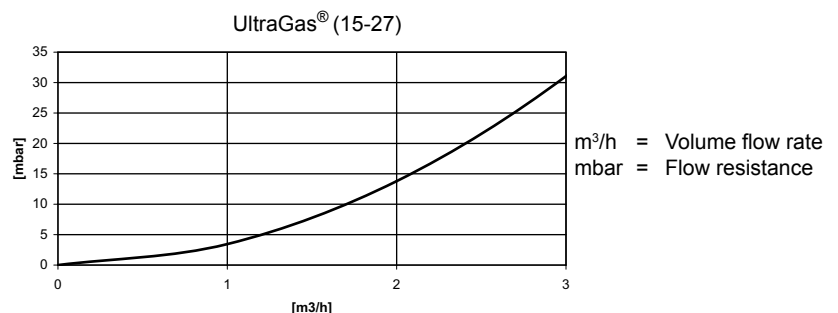

Technical Data

UltraGas® (35-100)

Type		(35)	(50)	(70)	(100)
• Nominal output 80/ 60 °C with natural gas	kW	5.2 - 32.8	7.5 - 46.1	12.2 - 64.0	19.0 - 92.0
• Nominal output 40/ 30 °C with natural gas	kW	5.8 - 35.7	8.3 - 50.1	13.6 - 69.9	20.9 - 100.0
• Nominal output 80/ 60 °C with liquid gas ¹	kW	6.9 - 32.2	9.9 - 45.5	15.4 - 63.3	23.0 - 92.0
• Nominal output 40/ 30 °C with liquid gas ¹	kW	7.7 - 35.7	10.9 - 50.5	17.1 - 69.9	25.3 - 100.0
• Nominal load with natural gas	kW	5.4 - 33.3	7.7 - 46.9	12.5 - 65.5	19.6 - 94.1
• Nominal load with liquid gas ¹	kW	7.2 - 33.4	10.2 - 47.2	16.0 - 65.5	23.8 - 94.1
• Working pressure heating max./min. ²	bar	3.0 / 1.2	3.0 / 1.2	4.0 / 1.2	4.0 / 1.2
• Working temperature max.	°C	85	85	85	85
• Boiler water content	l	81	75	157	144
• Min. water flow rate ³	l/h	0	0	0	0
• Boiler weight (without water content, incl. casing)	kg	161	174	249	280
• Boiler efficiency according to EN 303 Partial load 30% (related to net / gross calorific value)	%	108.1 / 97.4	108.1 / 97.4	108.1 / 97.4	108.1 / 97.4
• Standard efficiency (related to net / gross calorific value) 40/ 30 °C	%	109.5 / 98.6	109.5 / 98.6	109.6 / 98.7	109.1 / 98.3
• Standard efficiency (related to net / gross calorific value) 75/ 60 °C	%	107.0 / 96.4	107.0 / 96.4	107. / 96.5	107.1 / 96.5
• Heat loss rate at 70 °C	Watt	220	220	290	290
• Standard emission rate Nitrogen oxides ⁴	mg/kWh	30	31	31	39
• Standard emission rate Carbon monoxide	mg/kWh	11	4	3	3
• Content of CO ₂ in the exhaust gas max./min. output	%	9,0 / 8,8	9,0 / 8,8	9,0 / 8,8	9,0 / 8,8
• Dimensions	See table of dimensions				
• Connections Flow/return	Inches	R 1¼"	R 1¼"	R 1½"	R 1½"
• Connections Gas	Inches	Rp ¾"	Rp ¾"	R ¾"	R ¾"
• Connections Flue gas/ combustion air Ø	mm	E80	E80	C100/150	C100/150
• Gas flow pressure min./max. Natural gas E	mbar	15-50	15-50	15-50	15-50
• Gas flow pressure min./max. Liquid gas	mbar	37-50	37-50	37-50	37-50
• Gas connection value at 0 °C / 1013 mbar: Natural gas E - (W _o = 15,0 kWh/m ³) H _u = 9,97 kWh/m ³	m ³ /h	3.3	4.7	6.6	9.4
• Gas connection value at 0 °C / 1013 mbar: Propane gas (H _u = 25,9 kWh/m ³)	m ³ /h	1.3	1.8	2.5	3.6
• Operation voltage	V/Hz	230 / 50	230 / 50	230 / 50	230 / 50
• Control voltage	V/Hz	24 / 50	24 / 50	24 / 50	24 / 50
• Min./max. electrical power consumption	Watt	26 / 59	26 / 64	27 / 93	27 / 158
• Stand-by electrical consumption	Watt	12	12	12	12
• IP rating (integral protection)	IP	20	20	20	20
• Acoustic power level max.	dB(A)	62	60	64	67
• Acoustic power level at 1 metre ²	dB(A)	55	53	57	59
• Condensate quantity (natural gas) at 40 / 30 °C	l/h	3.1	4.4	6.2	8.9
• pH value of the condensate		ca. 4.2	ca. 4.2	ca. 4.2	ca. 4.2
• Values for flue calculation Temperature class		T120	T120	T120	T120
• Values for flue calculation Flue gas mass flow	kg/h	55.0	78.0	109.0	157.0
• Values for flue calculation Flue gas temperature with operating conditions 80 / 60 °C	°C	65	64	63	65
• Values for flue calculation Flue gas temperature with operating conditions 40 / 30 °C	°C	42	43	43	43
• Values for flue calculation Volume flow rate combustion air	Nm ³ /h	41	58	81	106
• Values for flue calculation Usable overpressure for air duct/flue system	Pa	120	120	130	130

¹ UltraGas (35-100) can also be operated with propane/butane (liquid gas) mixtures.

² Boiler test pressure is 1.5 times max. operating pressure.

³ Although generally the UltraGas boilers do not require a minimum water flow, it does not mean that the pump and burner can be switched off together when the unit is operating at full output. There should be a pump overrun to dissipate any residual heat within the boiler to avoid nuisance high temperature lockouts.

⁴ NOx emissions to EN676 are dry and at 0% excess oxygen.

• Boiler flow resistance see diagrams below.

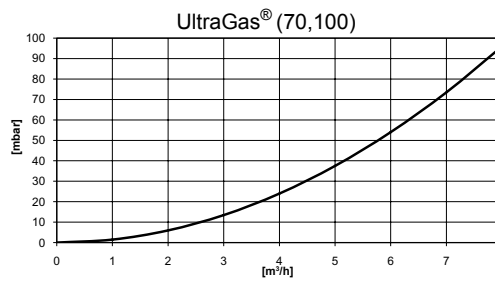
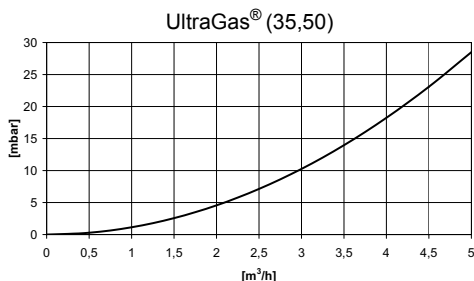

m³/h = Volume flow rate
mbar = Flow resistance

Dimensions

Hoval UltraGas® (70, 100) with optional connection set AS40-S/NT/ HT and heating circuit set HA40
(Measurements in mm)

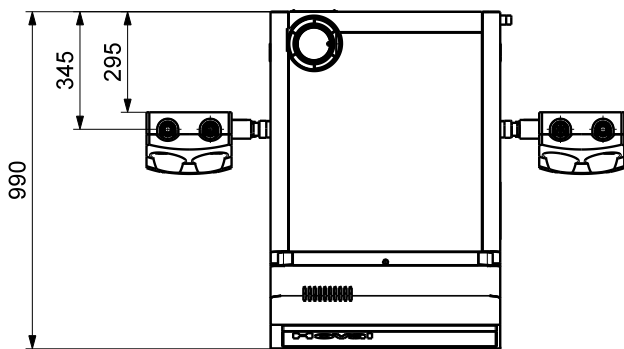
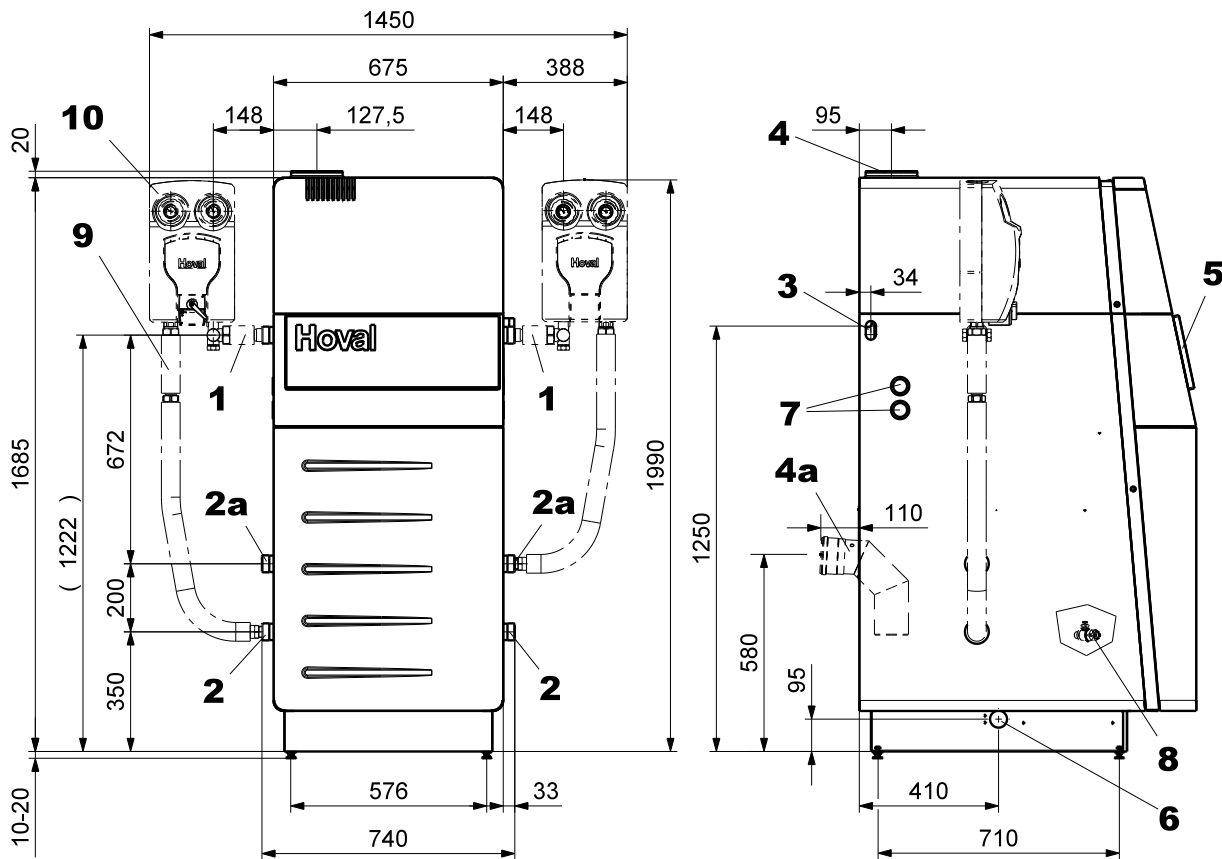

Type UltraGas®	(70)	(100)
1. Flow	R1½"	R1½"
2. Low temperature return	R1½"	R1½"
2a. High temperature return	R1½"	R1½"
3. Gas connection left or right	Rp ¾"	Rp ¾"
4. Flue gas outlet (concentric)	C100/150	C100/150
4a. Horizontal flue gas connection (optional)	E100	E 100
5. Control panel		
6. Condensate drain (left or right) incl. trap (DN25) and 2 m PVC hose D19 x 4mm		
7. Electrical connection left or right		
8. Drain (behind the front casing)	½"	½"
9. Connection set (optional) can be fitted left or right hand side		
10. Heating circuit set (optional), versions available for left or right hand side, refer to accessories section		

The installer must fit a safety valve and automatic air vent in the flow pipework before any isolation valve or on the second flow connection.

Dimensions

Hoval UltraGas® (15-50)

(Measurements in mm)

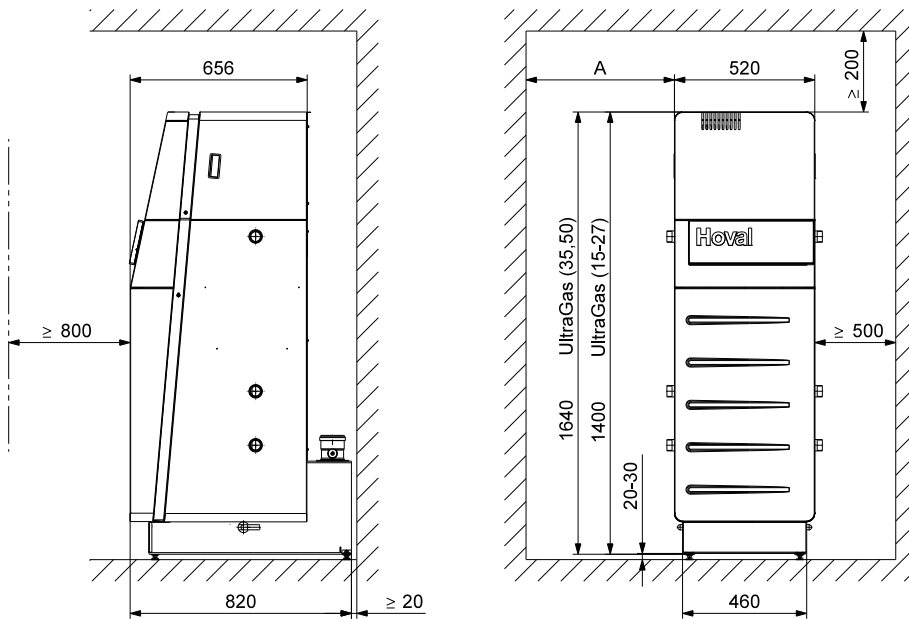

A = minimum 150 mm (300mm or more recommended to allow burner to rotate to the left for maintenance). Clearances are without the optional connection sets.

Where a condensate pump is used (see Accessories) allow at least 200mm clearance on the side where this will be positioned.

Hoval UltraGas® (70, 100)

(Measurements in mm)

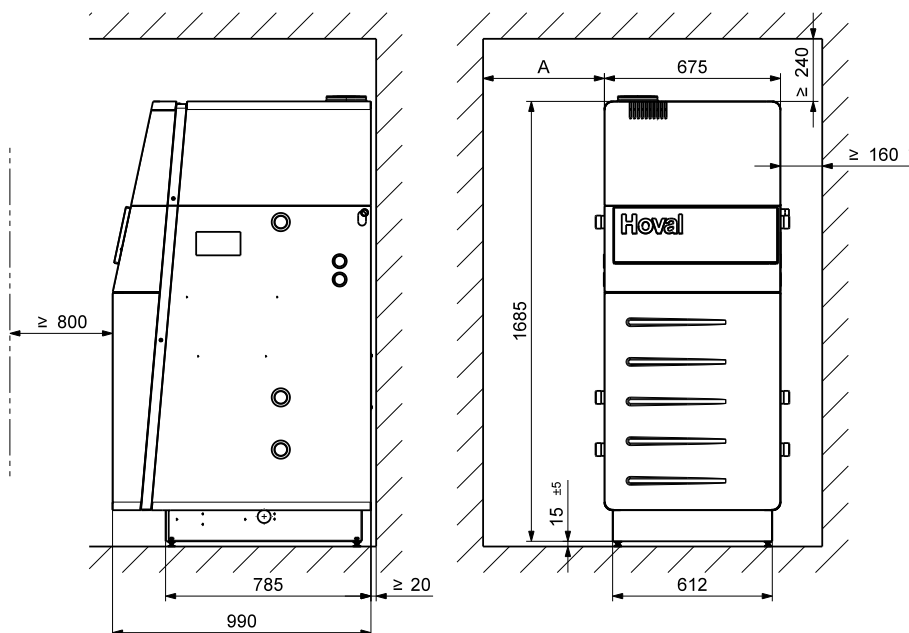

A = minimum 150 mm (300mm or more recommended to allow burner to rotate to the left for maintenance). Clearances are without the optional connection sets.

Where a condensate pump is used (see Accessories) allow at least 200mm clearance on the side where this will be positioned.

Technical Data

UltraGas® (125-300)

Type		(125)	(150)	(200)	(250)	(300)
• Nominal output 80/ 60 °C with natural gas	kW	25 - 114	25 - 139	39 - 185	44 - 231	51 - 278
• Nominal output 40/ 30 °C with natural gas	kW	28 - 125	28 - 150	44 - 200	49 - 250	57 - 300
• Nominal output 80/ 60 °C with liquid gas ¹	kW	31 - 113	35 - 138	63 - 185	78 - 230	80 - 278
• Nominal output 40/ 30 °C with liquid gas ¹	kW	34 - 125	39 - 150	70 - 200	87 - 250	91 - 300
• Nominal load with natural gas	kW	26 - 116	26 - 141	40 - 188	45 - 235	52 - 283
• Nominal load with liquid gas ¹	kW	32 - 116	36 - 141	65 - 190	80 - 235	84 - 283
• Working pressure heating max./min. ²	bar	5.0 / 1.2	5.0 / 1.2	5.0 / 1.2	5.0 / 1.2	5.0 / 1.2
• Working temperature max.	°C	90	90	90	90	90
• Boiler water capacity	l	206	194	359	341	318
• Min. water flow rate ³	l/h	0	0	0	0	0
• Boiler weight (without water content, incl. casing)	kg	383	409	634	672	724
• Boiler efficiency according to EN 303 Partial load 30% (related to net / gross calorific value)	%	108.1/97.4	108/97.5	108.1/97.4	108.1/97.4	108.0/97.3
• Standard efficiency (related to net / gross calorific value)	40/ 30 °C % 75/ 60 °C %	109.6/98.7 107.1/96.5	109.6/98.7 107.1/96.5	109.7/98.8 107.2/96.6	109.7/98.8 107.2/96.6	109.7/98.8 107.2/96.6
• Heat loss rate at 70 °C	Watt	480	480	530	530	530
• Standard emission rate	Nitrogen oxides ⁴ mg/kWh Carbon monoxide mg/kWh	35 3	34 4	32 4	34 4	32 9
• Content of CO ₂ in the exhaust gas max./min. output	%	9.0 / 8.8	9.0 / 8.8	9.0 / 8.8	9.0 / 8.8	9.0 / 8.8
• Dimensions	see table of dimensions					
• Connections	Flow/return Gas Flue gas inside	DN Inches Ø mm	DN65/PN6 Rp1" 155	DN65/PN6 Rp1" 155	DN65/PN6 Rp1½" 252	DN65/PN6 Rp1½" 252
• Gas flow pressure min./max.						
Natural gas E	mbar	15-80	15-80	15-80	15-80	15-80
Propane gas	mbar	37-57	37-57	37-57	37-57	37-57
• Gas connection value at 0°C / 1013 mbar:						
Natural gas E - (W _o = 15,0 kWh/m ³) H _u = 9,97 h/m ³	m ³ /h	11,6	14,1	18,8	23,5	28,3
Propane gas ³ (H _u = 25,9 kWh/m ³)	m ³ /h	4,5	5,4	7,3	9,1	10,9
• Operation voltage	V/Hz	230/50	230/50	230/50	230/50	230/50
• Control voltage	V/Hz	24/50	24/50	24/50	24/50	24/50
• Min./max. electrical power consumption	Watt	44/168	44/247	44/143	44/224	46/345
• Stand-by	Watt	12	12	12	12	12
• IP rating (integral protection)	IP	20	20	20	20	20
• Acoustic power level max.	dB(A)	69	72	65	68	72
• Acoustic pressure level at 1 metre	dB(A)	59	62	55	58	62
• Condensate quantity (natural gas) at 40/ 30 °C	l/h	10,9	13,3	17,7	22,1	26,6
• pH value of the condensate		ca. 4,2	ca. 4,2	ca. 4,2	ca. 4,2	ca. 4,2
• Values for flue calculation:						
Temperature class		T120	T120	T120	T120	T120
Flue gas mass flow	kg/h	192	234	312	330	470
Flue gas temperature with operating conditions 80/ 60 °C	°C	69	71	69	70	71
Flue gas temperature with operating conditions 40/ 30 °C	°C	48	49	48	49	49
Volume flow rate combustion air	Nm ³ /h	143	175	233	291	350
Usable overpressure for air duct/flue system	Pa	100	120	120	130	130

¹ UltraGas (125-300) can also be operated with propane/butane (liquid gas) mixtures.

² Boiler test pressure is 1.5 times max. operating pressure.

³ Although generally the UltraGas boilers do not require a minimum water flow, it does not mean that the pump and burner can be switched off together when the unit is operating at full output. There should be a pump overrun to dissipate any residual heat within the boiler to avoid nuisance high temperature lockouts.

⁴ NOx emissions to EN676 are dry and at 0% excess oxygen.

• Boiler flow resistance see diagrams below.

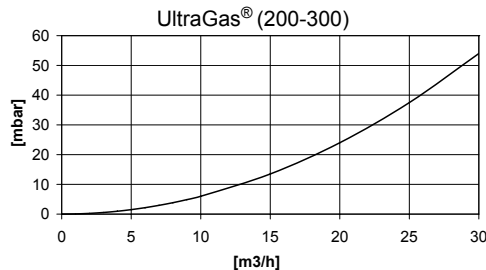
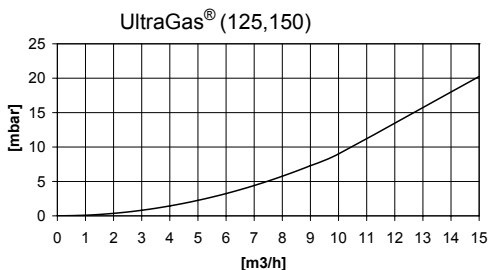

m³/h = Volume flow rate
mbar = Flow resistance

Technical Data

UltraGas® (350-575)

Type		(350)	(400)	(450)	(500)	(575)	
• Nominal output 80/ 60 °C with natural gas	kW	51 - 324	87 - 371	87 - 417	87 - 463	122 - 533	
• Nominal output 40/ 30 °C with natural gas	kW	58 - 350	97 - 400	97 - 450	97 - 500	136 - 575	
• Nominal output 80/ 60 °C with liquid gas ¹	kW	95 - 320	139 - 370	139 - 410	139 - 455	169 - 524	
• Nominal output 40/ 30 °C with liquid gas ¹	kW	109 - 350	154 - 400	154 - 450	154 - 500	185 - 575	
• Nominal load with natural gas	kW	53 - 330	89 - 377	89 - 424	89 - 471	125 - 542	
• Nominal load with liquid gas ¹	kW	100 - 330	144 - 377	144 - 424	144 - 471	175 - 542	
• Working pressure heating max./min. ²	bar	6.0 / 1.2	6.0 / 1.2	6.0 / 1.2	6.0 / 1.2	6.0 / 1.2	
• Working temperature max.	°C	90	90	90	90	90	
• Boiler water content	l	428	411	387	375	549	
• Minimum water flow rate ³	l/h	0	0	0	0	0	
• Boiler weight (without water content, incl. casing)	kg	865	903	955	981	1283	
• Boiler efficiency at partial load 30% (according to EN 303) (related to net / gross calorific value)	%	108.0 / 97.3	108.1 / 97.4	108.0 / 97.3	108.0 / 97.3	108.1 / 97.4	
• Standard efficiency (related to net / gross calorific value)	40/ 30 °C % 75/ 60 °C %	109.8 / 98.9 107.3 / 96.7	109.8 / 98.9 107.3 / 96.7	109.8 / 98.9 107.3 / 96.7	109.8 / 98.9 107.3 / 96.7	109.9 / 99.0 107.4 / 96.8	
• Heat loss rate at 70 °C	Watt	750	750	750	750	1000	
• Standard emission rate	Nitrogen oxides ⁴ mg/kWh Carbon monoxide mg/kWh	38 10	37 11	37 12	37 13	36 5	
• Content of CO ₂ in the exhaust gas max./min. output	%	9.0 / 8.8	9.0 / 8.8	9.0 / 8.8	9.0 / 8.8	9.0 / 8.8	
• Dimensions	see table of dimensions						
• Connections	Flow/return	DN	DN100/ PN6	DN100/ PN6	DN100/ PN6	DN100/ PN6	DN125/ PN6
	Gas	Inches	Rp 1½"	Rp 2"	Rp 2"	Rp 2"	Rp 2"
	Flue gas inside	Ø mm	302	302	302	302	302
• Gas flow pressure min./max.							
Natural gas E	mbar	18-80	15-80	15-80	15-80	15-80	
Propane gas	mbar	37-57	37-57	37-57	37-57	37-57	
• Gas connection value at 0°C / 1013 mbar:							
Natural gas E - (W _o = 15,0 kWh/m ³) H _u = 9,97 h/m ³	m ³ /h	32.6	37.7	42.4	47.1	54.2	
Propane gas ³ (H _u = 25,9 kWh/m ³)	m ³ /h	12.6	14.6	16.4	18.2	20.9	
• Operation voltage	V/Hz	230/50	230/50	230/50	230/50	230/50	
• Control voltage	V/Hz	24/50	24/50	24/50	24/50	24/50	
• Min./max. electrical power consumption	Watt	49/330	60/445	60/582	60/745	62/720	
• Stand-by	Watt	12	12	12	12	12	
• IP rating (integral protection)	IP	20	20	20	20	20	
• Acoustic power level max.	dB(A)	74	71	73	75	72	
• Acoustic pressure level at 1 metre	dB(A)	64	61	63	65	62	
• Condensate quantity (natural gas) at 40/ 30 °C	l/h	30.6	35.4	39.9	44.3	50.9	
• pH value of the condensate		ca. 4.2	ca. 4.2	ca. 4.2	ca. 4.2	ca. 4.2	
• Values for flue calculation:							
Temperature class		T120	T120	T120	T120	T120	
Flue gas mass flow	kg/h	541	626	704	782	900	
Flue gas temperature with operating conditions 80/ 60 °C	°C	69	71	71	72	71	
Flue gas temperature with operating conditions 40/ 30 °C	°C	46	48	47	49	47	
Volume flow rate combustion air	Nm ³ /h	404	467	525	583	671	
Usable overpressure for air duct/flue system	Pa	130	130	130	130	130	

¹ UltraGas (350-575) can also be operated with propane/butane (liquid gas) mixtures.

² Boiler test pressure is 1.5 times max. operating pressure.

³ Although generally the UltraGas boilers do not require a minimum water flow, it does not mean that the pump and burner can be switched off together when the unit is operating at full output. There should be a pump overrun to dissipate any residual heat within the boiler to avoid nuisance high temperature lockouts.

⁴ NOx emissions to EN676 are dry and at 0% excess oxygen.

• Boiler flow resistance see diagrams below .

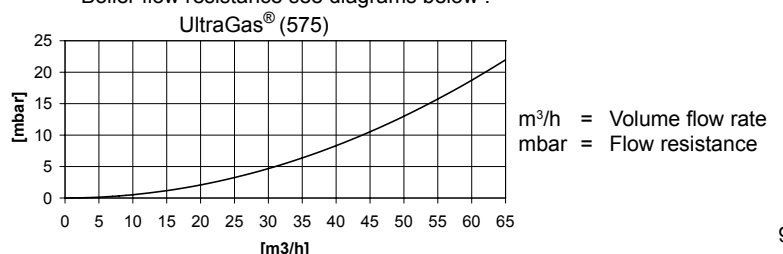
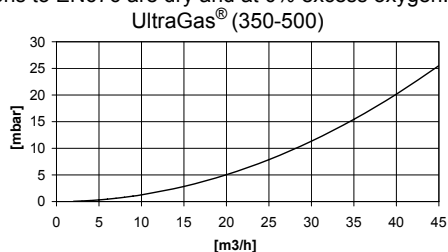

Technical Data

UltraGas® (650-1000)

Type		(650)	(720)	(850)	(1000)
• Nominal output 80/ 60 °C with natural gas	kW	122 - 603	127 - 665	148 - 788	199 - 927
• Nominal output 40/ 30 °C with natural gas	kW	136 - 650	142 - 720	166 - 850	224 - 1000
• Nominal output 80/ 60 °C with liquid gas ¹	kW	169 - 592	169 - 655	235 - 789	269 - 927
• Nominal output 40/ 30 °C with liquid gas ¹	kW	185 - 650	185 - 720	257 - 851	293 - 1000
• Nominal load with natural gas	kW	125 - 613	130 - 677	152 - 802	205 - 943
• Nominal load with liquid gas ¹	kW	175 - 613	175 - 677	238 - 803	272 - 943
• Working pressure heating max./min. ²	bar	6.0 / 1.2	6.0 / 1.2	6.0 / 1.2	6.0 / 1.2
• Working temperature max.	°C	90	90	90	90
• Boiler water content	l	529	478	860	793
• Min. water flow rate ³	l/h	0	0	0	0
• Boiler weight (without water content, incl. casing)	kg	1328	1438	1743	1893
• Boiler efficiency at partial load 30% (according to EN 303) (related to net / gross calorific value)	%	108.0 / 97.3	108.0 / 97.3	108.1 / 97.4	108.1 / 97.4
• Standard efficiency (according to DIN 4702 part 8) 40/ 30 °C (related to net / gross calorific value)	%	109.9 / 99.0	109.9 / 99.0	109.9 / 99.0	109.9 / 99.0
	75/ 60 °C	%	107.4 / 96.8	107.4 / 96.8	107.4 / 96.8
• Heat loss rate at 70 °C	Watt	1000	1000	1200	1200
• Standard emission rate Nitrogen oxides ⁴	mg/kWh	39	35	37	35
	Carbon monoxide	mg/kWh	5	5	15
• Content of CO ₂ in the exhaust gas max./min. output	%	9.0 / 8.8	9.0 / 8.8	9.0 / 8.8	9.0 / 8.8
• Dimensions		see table of dimensions			
• Connections	Flow/return	DN	DN125/ PN6	DN125/ PN6	DN125/ PN6
	Gas	Inches	Rp 2"	Rp 2"	Rp 2"
	Flue gas Ø inside	mm	302	302	402
• Gas flow pressure min./max.					
Natural gas E	mbar	15-80	18-80	15-80	15-80
Propane gas	mbar	37-57	37-57	37-57	37-57
• Gas connection value at 0°C / 1013 mbar:					
Natural gas E - (W _o = 15,0 kWh/m ³) H _u = 9,97 h/m ³	m ³ /h	61.3	67.7	80.2	94.3
Propane gas ³ (H _u = 25,9 kWh/m ³)	m ³ /h	23.7	26.1	31.0	36.4
• Operation voltage	V/Hz	230/50	230/50	230/50	1x230/50 3x400/50
• Control voltage	V/Hz	24/50	24/50	24/50	24/50
• Min./max. electrical power consumption	Watt	62/1030	65/1050	52/1010	106/2730
• Stand-by	Watt	12	12	12	12
• IP rating (integral protection)	IP	20	20	20	20
• Acoustic power level max.	dB(A)	75	77	77	82
• Acoustic pressure level at 1 metre	dB(A)	65	67	67	72
• Condensate quantity (natural gas) at 40/ 30°C	l/h	57.6	63.6	75.4	88.9
• pH value of the condensate		ca. 4.2	ca. 4.2	ca. 4.2	ca. 4.2
• Values for flue calculation:					
Temperature class		T120	T120	T120	T120
Flue gas mass flow	kg/h	1018	1124	1331	1565
Flue gas temperature with operating conditions 80/ 60 °C	°C	72	71	69	69
Flue gas temperature with operating conditions 40/ 30 °C	°C	49	46	49	49
Volume flow rate combustion air	Nm ³ /h	759	838	992	1167
Usable overpressure for air duct/flue system	Pa	130	130	130	130

¹ UltraGas (650-1000) can also be operated with propane/butane (liquid gas) mixtures.

² Boiler test pressure is 1.5 times max. operating pressure.

³ Although generally the UltraGas boilers do not require a minimum water flow, it does not mean that the pump and burner can be switched off together when the unit is operating at full output. There should be a pump overrun to dissipate any residual heat within the boiler to avoid nuisance high temperature lockouts.

⁴ NOx emissions to EN676 are dry and at 0% excess oxygen. • Boiler flow resistance see diagrams.

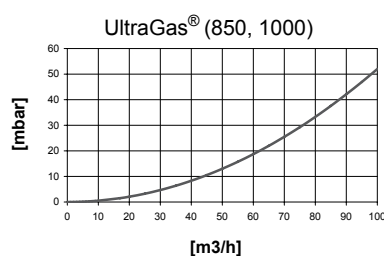
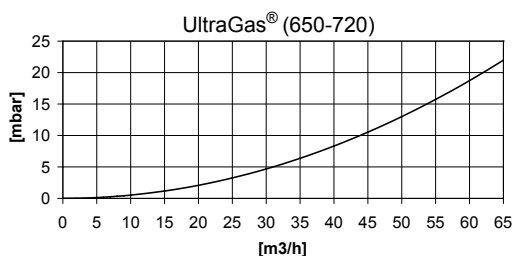

m³/h = Volume flow rate
mbar = Flow resistance

Dimensions

UltraGas® (125-1000)

(All Measurements in mm)

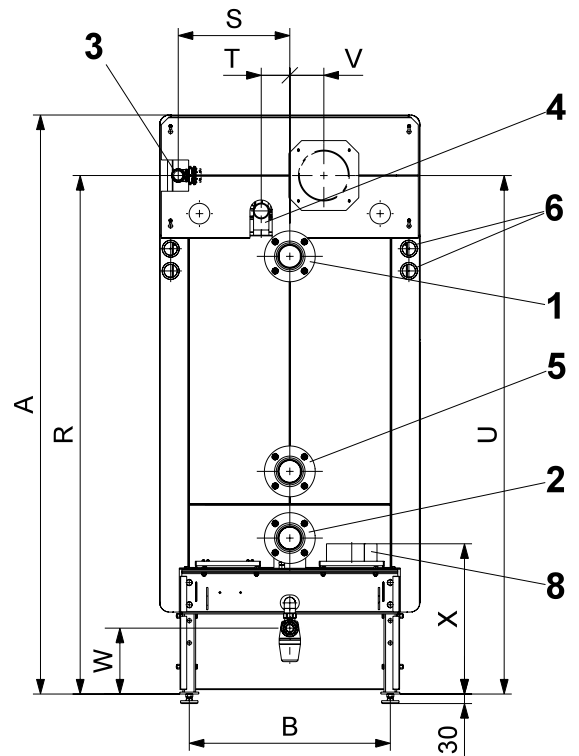
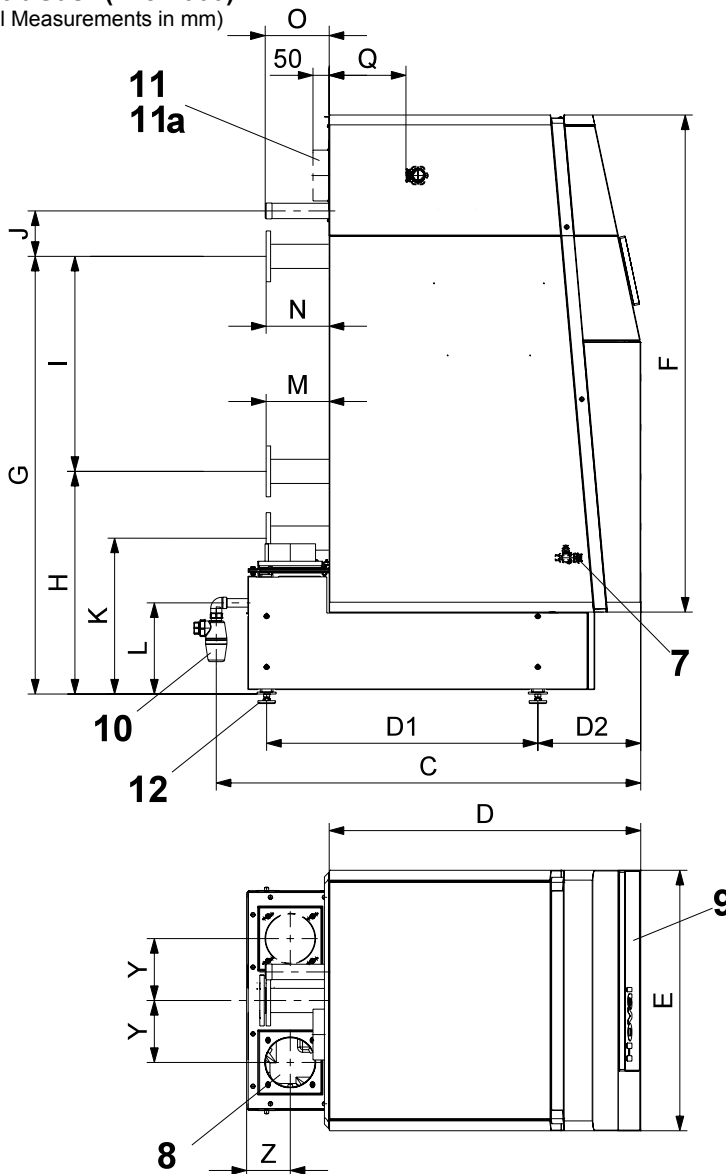

Note: see separate page for installation clearances. The boiler height can be reduced provided clearance is maintained for the condensate discharge trap, item 10 (gravity drain only). For details see page 14.

IMPORTANT: A loose Rp 2" fine gas filter is supplied with each UltraGas® 400 - 1000 boiler for fitting by the installer adjacent to the boiler concerned. Suitable isolation should be provided to facilitate routine filter pad replacement.

- 1 Flow
- 2 Low temperature return
- 3 Gas connection left or right
- 4 Safety valve or calorifier primary ¹
- 5 High temperature return
- 6 Electrical connection left or right
- 7 Drain (behind the front casing)
- 8 Flue gas connection left or right
- 9 Boiler control panel (with space for additional TopTronic®)
- 10 Condensate discharge with trap
- 11 Air inlet connector (optional)
- 11a Motorised air intake shut off damper (optional)
- 12 Boiler feet adjustable up to 80 mm

Type	A	B	C	D	D1	E	F	G	H	I	J	K	L	M	N	O	Q	R
(125,150)	1823	633	1336	981	854	820	1565	1378	701	677	143	491	287	199	199	200	242	1633
(200-300)	1923	743	1684	1247	1204	930	1667	1428	718	710	155	498	287	280	200	186	368	1696
(350)	2070	923	1775	1268	1294	1110	1800	1438	808	630	160	528	284	345	205	205	345	1720
(400-500)	2070	923	1775	1268	1294	1110	1800	1438	808	630	160	528	284	345	205	205	-12	1829
(575-720)	2086	1103	1928	1438	1480	1290	1800	1442	834	608	202	554	284	367	367	110	86	1847
(850,1000)	2139	1363	2243	1703	1790	1550	1854	1494	858	636	204	578	294	417	417	218	198	1888

Type	S	T	U	V	W	X	Y	Z	1,2,5	3	4	8	10	11	11b
(125,150)	351	90	1632	107	207	473	195	138	DN 65 / PN6 / 4 S	Rp 1"	R 1 1/2"	Ø155/159	DN25	Ø122/125	DN 110
(200-300)	371	100	1702	108	207	472	217	183	DN 65 / PN6 / 4 S	Rp 1 1/2"	R 1 1/2"	Ø252/256	DN25	Ø197/200	DN 110
(350)	435	100	1730	100	204	484	267	210	DN 100 / PN6 / 4 S	Rp 1 1/2"	R 1 1/2"	Ø302/306	DN25	Ø197/200	DN 110
(400-500)	447	100	1812	176	204	484	267	210	DN 100 / PN6 / 4 S	Rp 2"	R 1 1/2"	Ø302/306	DN25	Ø247/250	DN 180
(575-720)	513	100	1818	176	204	530	357	218	DN 125 / PN6 / 8 S	Rp 2"	R 2"	Ø302/306	DN40	Ø247/250	DN 180
(850,1000)	624	100	1880	176	214	554	455	243	DN 125 / PN6 / 8 S	Rp 2"	R 2"	Ø402/406	DN40	Ø247/250	DN 180

¹AAV must be fitted before any isolation valve

* DN = nominal diameter, PN = nominal pressure, S = number of bolt holes in flange, example DN65 / PN6 / 4S

Dimensions

UltraGas® (125-1000)

Boiler without casing and insulation
(All measurements in mm)

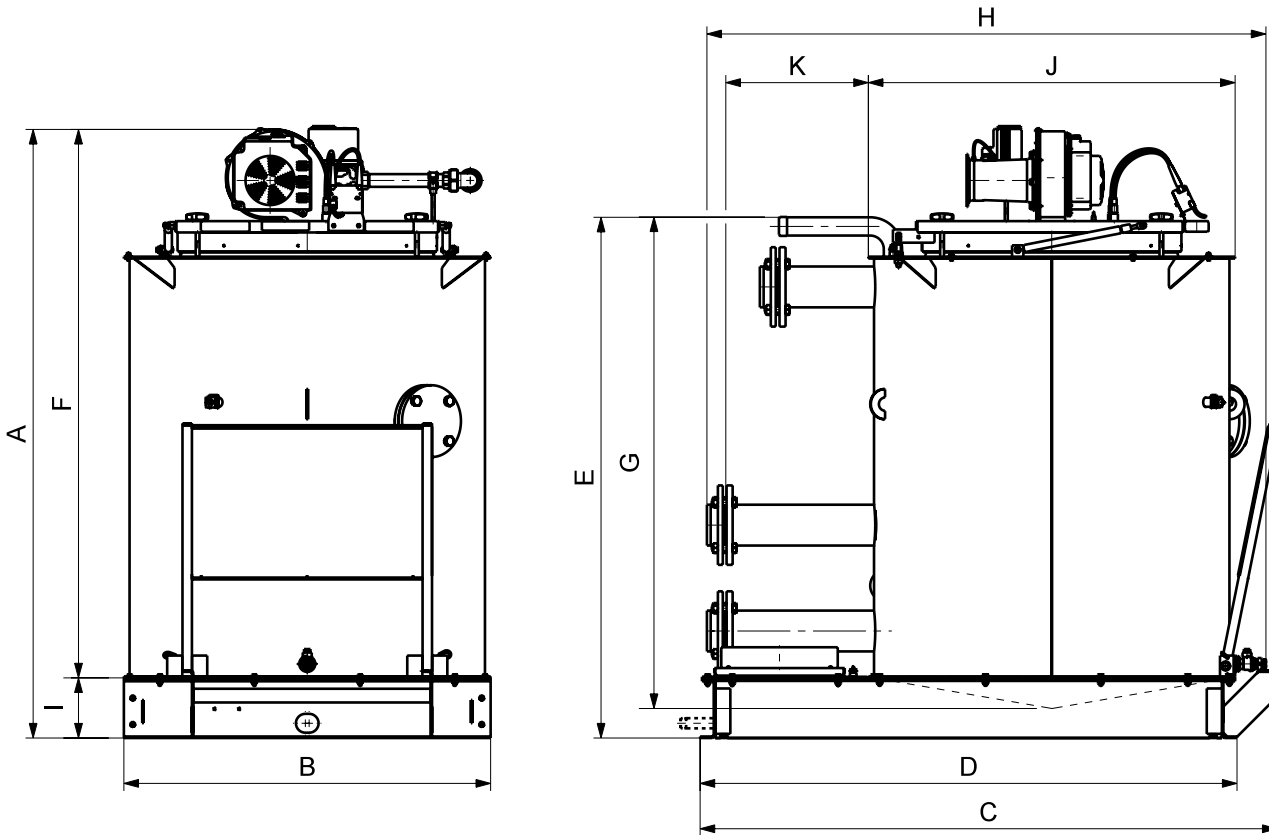

UltraGas® Type	A	B	C	D	E	F	G	H	I	J	K
(125,150)	1520	680	1072	980	1295	1380	1191	1040	140	680	236
(200-300)	1585	790	1422	1330	1355	1445	1260	1390	140	950	316
(350)	1610	970	1530	1420	1380	1450	1272	1480	160	970	377
(400-500)	1810	970	1530	1420	1380	1650	1272	1480	160	970	377
(575-720)	1810	1150	1720	1605	1400	1635	1316	1690	175	1150	408
(850,1000)	1885	1410	2027	1916	1483	1686	1375	2000	199	1410	458

Required min. width of door and corridor to bring in the boiler

The following are minimal dimensions

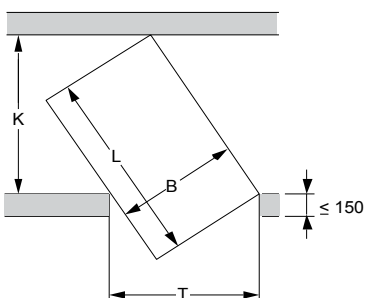

$$K = \frac{B}{T} \times L$$

$$T = \frac{B}{K} \times L$$

- B = Boiler width
- L = max. length of boiler
- T = Door width
- K = Corridor width

UltraGas® 125-1000 and 250D-2000D are delivered with the insulation, casings and control panel packed separately for fitting by the installer.

Calculation example for the necessary corridor width

Door width T = 1000

$$\text{UltraGas® (400-500)} \quad K = \frac{970}{1000} \times 1531 = \text{corridor width} \geq 1486$$

Dimensions

Space requirements UltraGas® (125-1000)

(All Measurements in mm)

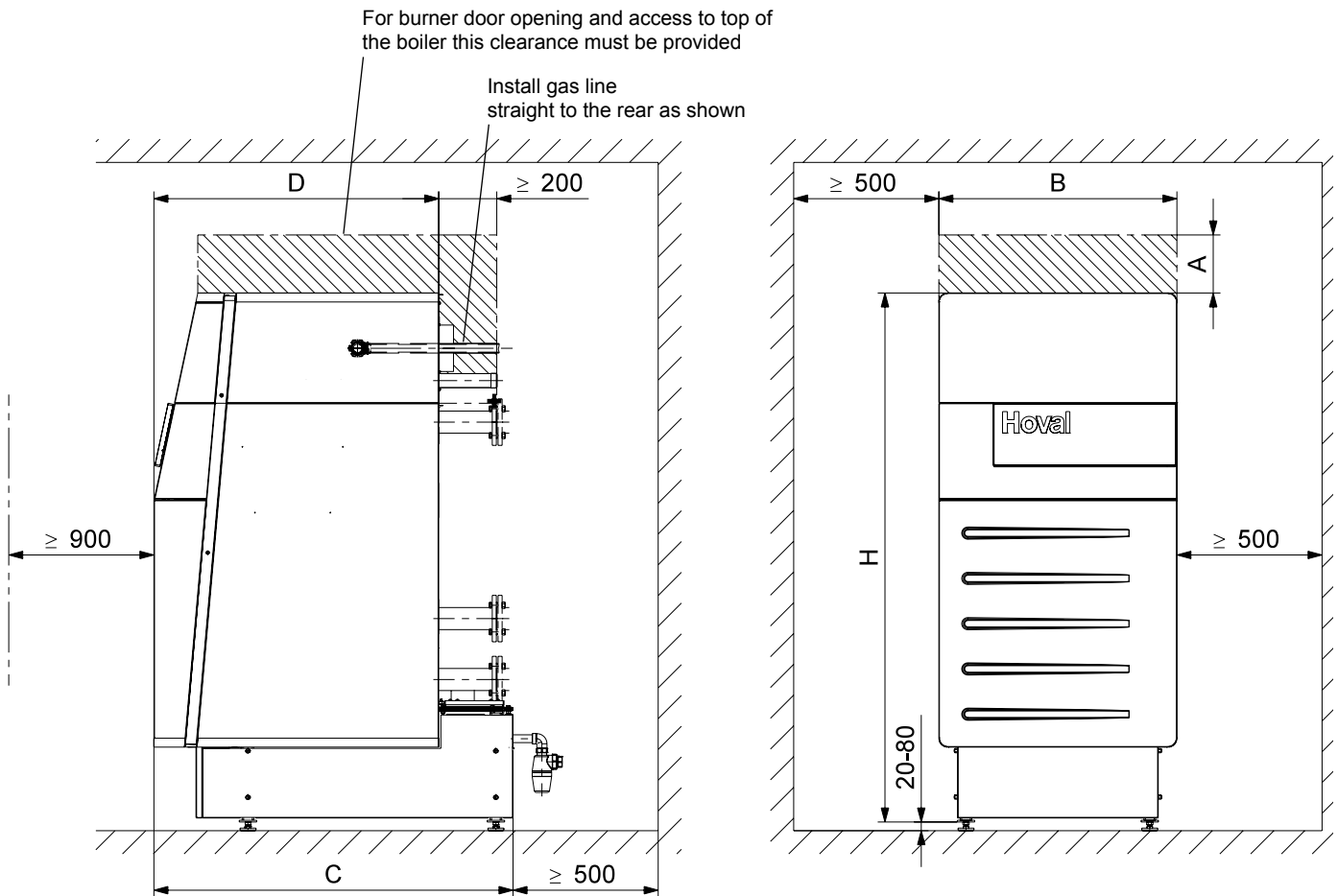

UltraGas® Type	A	A minimum	B	C	D	H	H minimum
(125, 150)	180 ¹	80 ²	820	1237	981	1823	1711 ³
(200 - 300)	360 ¹	160 ²	930	1584	1247	1923	1811 ³
(350 - 500)	200 ¹	100 ²	1110	1679	1268	2070	1958 ³
(575 - 720)	200 ¹	100 ²	1290	1843	1438	2086	1984 ³
(850, 1000)	420 ¹	230 ²	1550	2154	1703	2139	2037 ³

¹ If there is not sufficient room height, dimension A can be reduced to A minimum

² **Attention!** With A minimum the burner will no longer swing-open completely. This makes cleaning more difficult!

³ The boiler height can be reduced providing clearance is maintained for the condensate discharge trap. Please see page 14 for details.

⁴ If either side of the boiler has 500mm clearance the other side may be reduced to 100mm clearance.

Dimensions

Space requirements UltraGas® (125-1000)

(All Measurements in mm)

in addition allowance should be provided for the RP2" fine gas filter supplied with each UltraGas® 400 to 1000 boiler (Part No 2007998) as follows:

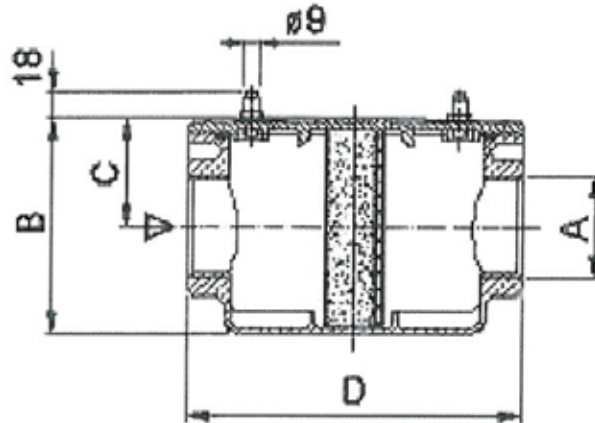

Fine gas filter installation and maintenance:

Each filter will be supplied loose for the Installer to fit adjacent to the boiler concerned. It should be possible for the gas filter to be isolated to allow the filter pad to be replaced as required (recommended to be done at least annually or when the pressure drop across the filter reaches 2.5 mbar. This can be measured across the two test points fitted on the filter top cover).

	A	B	C	D
Gas Filter	50	140	73	186

The pressure drop through a clean gas filter is as follows and needs to be taken into account by system designers along with an allowance for an increase if the filter becomes dirty:

UltraGas® 400	(0.5 mbar)
UltraGas® 450	(0.6 mbar)
UltraGas® 500	(0.8 mbar)
UltraGas® 575	(0.5 mbar)
UltraGas® 650	(0.6 mbar)
UltraGas® 720	(0.7 mbar)
UltraGas® 850	(1.0 mbar)
UltraGas® 1000	(1.4 mbar)

Dimensions

UltraGas® (125-1000) with shortened boiler feet

(All measurements in mm)

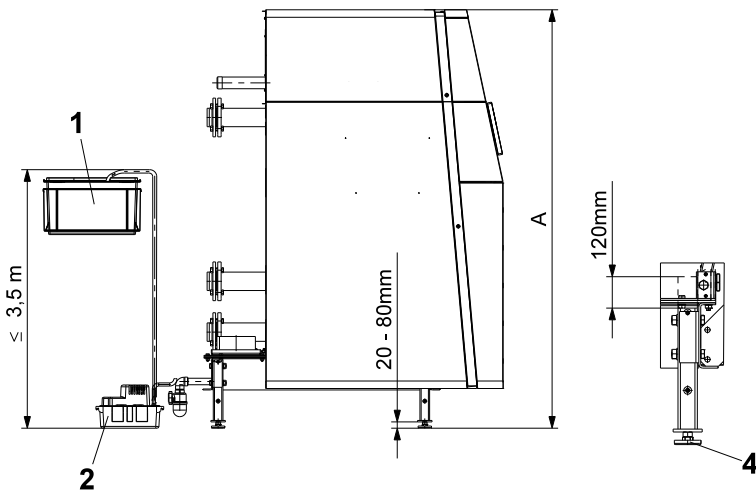

UltraGas® Type	A
(125, 150)	1723 - 1783
(200 - 300)	1823 - 1883
(350 - 500)	1970 - 2030
(575 - 720)	1986 - 2046
(850, 1000)	2039 - 2099

- 1 Neutralisation box (optional)
- 2 Condensate pump (optional)
- 3 Concrete plinth (not by Hoval)
- 4 Feet adjustable from 20-80 mm

UltraGas® (125-1000) with concrete plinth and adjustable feet

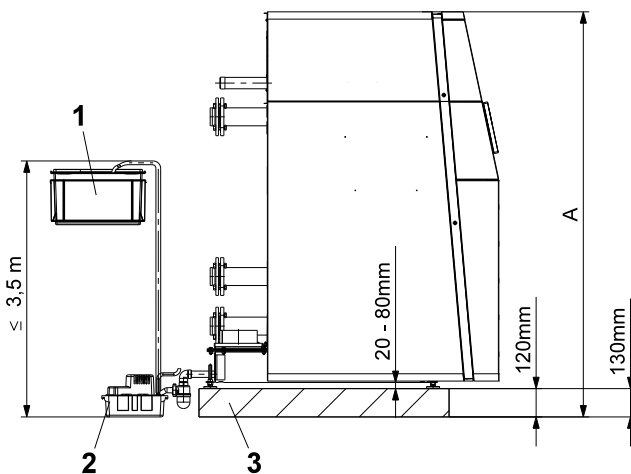

UltraGas® Type	A
(125, 150)	1711 - 1771
(200 - 300)	1811 - 1871
(350 - 500)	1958 - 2018
(575 - 720)	1984 - 2044
(850, 1000)	2037 - 2097

UltraGas® (125-1000) with concrete plinth without adjustable feet

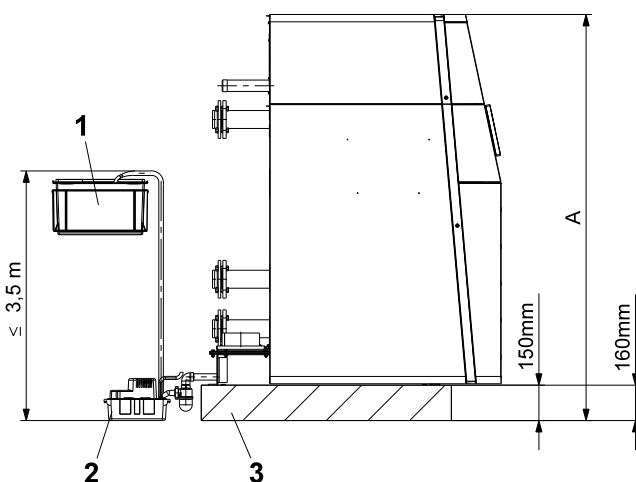

UltraGas® Type	A
(125, 150)	1721
(200 - 300)	1821
(350 - 500)	1968
(575 - 720)	1994
(850, 1000)	2047

Un-used boiler feet cannot be returned to Hoval for a refund.

Technical Data

UltraGas® (250D-700D)

Type		(250D)	(300D)	(400D)	(500D)	(600D)	(700D)	
• Nominal output 80/ 60 °C with natural gas	kW	25 - 228	25 - 278	39 - 370	44 - 462	51 - 556	51 - 648	
• Nominal output 40/ 30 °C with natural gas	kW	28 - 250	28 - 300	44 - 400	49 - 500	57 - 600	58 - 700	
• Nominal output 80/ 60 °C with liquid gas 1	kW	31 - 226	35 - 276	63 - 370	78 - 454	80 - 546	95 - 636	
• Nominal output 40/ 30 °C with liquid gas 1	kW	34 - 246	39 - 300	70 - 400	87 - 500	91 - 600	109 - 700	
• Nominal load with natural gas	kW	26 - 232	26 - 282	40 - 376	45 - 470	52 - 566	53 - 660	
• Nominal load with liquid gas 1	kW	32 - 232	36 - 282	65 - 376	80 - 470	84 - 566	100 - 660	
• Working pressure heating max./min. 2	bar	5.0 / 1.2	5.0 / 1.2	5.0 / 1.2	5.0 / 1.2	5.0 / 1.2	6.0 / 1.2	
• Working temperature max.	°C	90	90	90	90	90	90	
• Boiler water content	l	412	388	719	682	636	857	
• Minimum water flow rate 3	l/h	0	0	0	0	0	0	
• Boiler weight (without water content, incl. casing)	kg	766	818	1268	1344	1448	1730	
• Boiler efficiency at partial load 30% (according to EN 303) (related to net / gross calorific value)	%	108.1/97.4	108.0/97.3	108.1/97.4	108.1/97.4	108.0/97.3	108.0/97.3	
• Standard efficiency (according to DIN 4702 part 8) 40/ 30 °C (related to net / gross calorific value)	%	109.6/98.7	109.6/98.7	109.7/98.8	109.7/98.8	109.7/98.8	109.8/98.9	
75/ 60 °C	%	107.1/96.5	107.1/96.5	107.2/96.6	107.2/96.6	107.2/96.6	107.3/96.7	
• Stand-by loss at 70 °C	Watt	960	960	1060	1060	1060	1500	
• Standard emission rate								
	Nitrogen oxides 4	mg/kWh	35	34	32	34	32	38
	Carbon monoxide	mg/kWh	3	4	4	4	9	10
• Content of CO ₂ in the exhaust gas maximum/minimum output	%	9.0 / 8.8	9.0 / 8.8	9.0 / 8.8	9.0 / 8.8	9.0 / 8.8	9.0 / 8.8	
• Dimensions	See table of dimensions							
• Connections	Flow/return	DN	DN80/PN6	DN80/PN6	DN80/PN6	DN80/PN6	DN80/PN6	DN125/PN6
	Gas x2	Inches	1"	1"	1½"	1½"	1½"	1½"
	Flue gas Ø inside	mm	254	254	306	306	306	356
• Gas flow pressure min./max.								
Natural gas E	mbar	15-80	15-80	15-80	15-80	15-80	18-80	
Propane gas	mbar	37-57	37-57	37-57	37-57	37-57	37-57	
• Gas connection value at 0 °C / 1013 mbar:								
Natural gas E - (W _o = 15,0 kWh/m ³) H _u = 9,97 kWh/m ³	m ³ /h	23.1	28.2	37.6	47.0	56.6	65.2	
Propane gas (H _u = 32,7 kWh/m ³)	m ³ /h	8.9	10.9	14.5	18.1	21.9	25.2	
• Power Supply	V/Hz	230/50	230/50	230/50	230/50	230/50	230/50	
• Control voltage	V/Hz	24/50	24/50	24/50	24/50	24/50	24/50	
• Minimum/maximum electrical power consumption	Watt	44/336	44/494	44/286	44/448	46/690	49/660	
• Stand-by	Watt	24	24	24	24	24	24	
• IP rating (integral protection)	IP	20	20	20	20	20	20	
• Acoustic power level max.	dB(A)	72	75	69	72	75	77	
• Acoustic pressure level at 1 metre	dB(A)	62	65	59	62	65	67	
• Condensate quantity (natural gas) at 40/ 30 °C	l/h	21.7	26.5	35.3	44.2	53.2	61.3	
• pH value of the condensate	pH	ca. 4.2	ca. 4.2	ca. 4.2	ca. 4.2	ca. 4.2	ca. 4.2	
• Values for flue calculation:								
Temperature class		T120	T120	T120	T120	T120	T120	
Flue gas mass flow	kg/h	383	468	624	780	940	1082	
Flue gas temperature with operating conditions 80/60°C	°C	69	71	69	70	71	69	
Flue gas temperature with operating conditions 40/30°C	°C	48	49	48	49	49	46	
Volume flow rate combustion air	Nm ³ /h	286	349	465	582	701	807	
Usable overpressure for air duct/flue system	Pa	60	60	60	60	60	60	

¹ UltraGas (250D-700D) can also be operated with propane/butane (liquid gas) mixtures.

² Boiler test pressure is 1.5 times max. operating pressure.

³ Although generally the UltraGas boilers do not require a minimum water flow, it does not mean that the pump and burner can be switched off together when the unit is operating at full output. There should be a pump overrun to dissipate any residual heat within the boiler to avoid nuisance high temperature lockouts.

⁴ NOx emissions to EN676 are dry and at 0% excess oxygen.

• Boiler flow resistance see separate page.

• Note, from a controls point of view UltraGas D boilers are seen as two units. This means that each unit will require its own power supply and controls signals.

Technical Data

UltraGas® (800D-1300D)

Type		(800D)	(900D)	(1000D)	(1150D)	(1300D)
• Nominal output 80/ 60 °C with natural gas	kW	87 - 742	87 - 834	87 - 926	122 - 1066	122 - 1206
• Nominal output 40/ 30 °C with natural gas	kW	97 - 800	97 - 900	97 - 1000	136 - 1150	136 - 1300
• Nominal output 80/ 60 °C with liquid gas ¹	kW	139 - 728	139 - 820	139 - 910	169 - 1048	169 - 1184
• Nominal output 40/ 30 °C with liquid gas ¹	kW	154 - 800	154 - 900	154 - 1000	185 - 1150	185 - 1300
• Nominal load with natural gas	kW	89 - 754	89 - 848	89 - 942	125 - 1084	125 - 1226
• Nominal load with liquid gas ¹	kW	144 - 754	144 - 848	144 - 942	175 - 1084	175 - 1228
• Working pressure heating max./min. ²	bar	6.0 / 1.2	6.0 / 1.2	6.0 / 1.2	6.0 / 1.2	6.0 / 1.2
• Working temperature max.	°C	90	90	90	90	90
• Boiler water content	l	822	774	751	1098	1058
• Minimum water flow rate ³	l/h	0	0	0	0	0
• Boiler weight (without water content, incl. casingt)	kg	1806	1910	1962	2566	2656
• Boiler efficiency at partial load 30% (according to EN 303) (related to net / gross calorific value)	%	108.1/97.4	108.0/97.3	108.0/97.3	108.1/97.4	108.0/97.3
• Standard efficiency (according to DIN 4702 part 8) 40/ 30 °C (related to net / gross calorific value) 75/ 60 °C	%	109.8/98.9	109.8/98.9	109.8/98.9	109.9/99.0	109.9/99.0
• Stand-by loss at 70 °C	Watt	1500	1500	1500	2000	2000
• Standard emission rate Nitrogen oxides ⁴	mg/kWh	37	37	37	36	39
Carbon monoxide	mg/kWh	11	12	13	5	5
• Content of CO ₂ in the exhaust gas maximum/minimum output	%	9.0 / 8.8	9.0 / 8.8	9.0 / 8.8	9.0 / 8.8	9.0 / 8.8
• Dimensions	See table of dimensions					
• Connections	Flow/return	DN	DN125/PN6	DN125/PN6	DN125/PN6	DN150/PN6
	Gas x2	Inches	2"	2"	2"	2"
	Flue gas Ø inside	mm	356	356	356	356
• Gas flow pressure minimum/maximum						
Natural gas E	mbar	15-80	15-80	15-80	15-80	15-80
Propane gas	mbar	37-57	37-57	37-57	37-57	37-57
• Gas connection value at 0 °C / 1013 mbar:						
Natural gas E - (W _o = 15,0 kWh/m ³) H _u = 9,97 kWh/m ³	m ³ /h	75.4	84.9	94.3	108.5	122.7
Propane gas (H _u = 32,7 kWh/m ³)	m ³ /h	29.1	32.7	36.4	41.9	47.3
• Operation voltage	V/Hz	230/50	230/50	230/50	230/50	230/50
• Control voltage	V/Hz	24/50	24/50	24/50	24/50	24/50
• Minimum/maximum electrical power consumption	Watt	60/890	60/1164	60/1490	62/1440	62/2060
• Stand-by	Watt	24	24	24	24	24
• IP rating (integral protection)	IP	20	20	20	20	20
• Acoustic power level max	dB(A)	74	76	78	75	78
• Acoustic pressure level at 1 metre	dB(A)	64	66	68	65	68
• Condensate quantity (natural gas) at 40/ 30 °C	l/h	70.9	79.7	88.5	101.9	115.2
• pH value of the condensate	pH	ca. 4.2	ca. 4.2	ca. 4.2	ca. 4.2	ca. 4.2
• Values for flue calculation:						
Temperature class		T120	T120	T120	T120	T120
Flue gas mass flow	kg/h	1252	1408	1564	1799	2035
Flue gas temperature with operating conditions 80/ 60 °C	°C	71	71	72	71	72
Flue gas temperature with operating conditions 40/ 30 °C	°C	48	47	49	47	49
Volume flow rate combustion air	Nm ³ /h	933	1050	1166	1342	1518
Usable overpressure for air duct/flue system	Pa	60	60	60	60	60

¹ UltraGas (800D-1300D) can also be operated with propane/butane (liquid gas) mixtures.

² Boiler test pressure is 1.5 times max. operating pressure.

³ Although generally the UltraGas boilers do not require a minimum water flow, it does not mean that the pump and burner can be switched off together when the unit is operating at full output. There should be a pump overrun to dissipate any residual heat within the boiler to avoid nuisance high temperature lockouts.

⁴ NOx emissions to EN676 are dry and at 0% excess oxygen.

• Boiler flow resistance see separate page

• Note, from a controls point of view UltraGas D boilers are seen as two units. This means that each unit will require its own power supply and controls signals.

Technical Data

UltraGas® (1440D-2000D)

Type		(1440D)	(1700D)	(2000D)	
• Nominal output 80/ 60 °C with natural gas	kW	127-1330	148-1576	199-1854	
• Nominal output 40/ 30 °C with natural gas	kW	142-1440	166-1700	224-2000	
• Nominal output 80/ 60 °C with liquid gas ¹	kW	169-1310	235-1578	269-1854	
• Nominal output 40/ 30 °C with liquid gas ¹	kW	185-1440	257-1701	295-2000	
• Nominal load with natural gas	kW	130-1354	152-1604	205-1886	
• Nominal load with liquid gas ¹	kW	175-1354	238-1606	272-1886	
• Working pressure heating max./min. ²	bar	6.0 / 1.2	6.0 / 1.2	6.0 / 1.2	
• Working temperature max.	°C	90	90	90	
• Boiler water content	l	956	1720	1586	
• Minimum water flow rate ³	l/h	0	0	0	
• Boiler weight (without water content, incl. casing)	kg	2876	3486	3786	
• Boiler efficiency at partial load 30% (according to EN 303) (related to net / gross calorific value)	%	108.0/97.3	108.1/97.4	108.1/97.4	
• Standard efficiency (according to DIN 4702 part 8) (related to net / gross calorific value)	40/ 30 °C % 75/ 60 °C %	109.9/99.0 107.4/96.8	109.9/99.0 107.4/96.8	109.9/99.0 107.4/96.8	
• Stand-by loss at 70 °C	Watt	2000	2400	2400	
• Standard emission rate	Nitrogen oxides ⁴ Carbon monoxide	mg/kWh mg/kWh	35 15	35 15	
• Content of CO ₂ in the exhaust gas maximum/minimum output	%	9.0 / 8.8	9.0 / 8.8	9.0 / 8.8	
• Dimensions	See table of dimensions				
• Connections	Flow/return Gas x2 Flue gas Ø inside	DN Inches mm	DN150/PN6 2" 356	DN150/PN6 2" 502	DN150/PN6 2" 502
• Gas flow pressure minimum/maximum					
Natural gas E	mbar	18-80	15-80	15-80	
Propane gas	mbar	37-57	37-57	37-57	
• Gas connection value at 0 °C / 1013 mbar:					
Natural gas E - (W _o = 15,0 kWh/m ³) H _u = 9,97 kWh/m ³	m ³ /h	135.5	160.5	188.6	
Propane gas (H _u = 32,7 kWh/m ³)	m ³ /h	52.3	61.9	72.8	
• Operation voltage	V/Hz	230/50	230/50	1x 230/50 3x400/50	
• Control voltage	V/Hz	24/50	24/50	24/50	
• Minimum/maximum electrical power consumption	Watt	65/2300	52/2020	212/5460	
• Stand-by	Watt	24	24	24	
• IP rating (integral protection)	IP	20	20	20	
• Acoustic power level max.	dB(A)	80	80	85	
• Acoustic pressure level max.	dB(A)	70	70	75	
• Condensate quantity (natural gas) at 40/ 30 °C	l/h	127.3	150.8	177.8	
• pH value of the condensate	pH	ca. 4.2	ca. 4.2	ca. 4.2	
• Values for flue calculation:					
Temperature class		T120	T120	T120	
Flue gas mass flow	kg/h	2248	2663	3130	
Flue gas temperature with operating conditions 80/ 60 °C	°C	71	69	69	
Flue gas temperature with operating conditions 40/ 30 °C	°C	46	49	49	
Volume flow rate combustion air	Nm ³ /h	1676	1984	2334	
usable overpressure for air duct/flue system	Pa	60	60	60	

¹ UltraGas (1440D-2000D) can also be operated with propane/butane (liquid gas) mixtures.

² Boiler test pressure is 1.5 times max. operating pressure.

³ Although generally the UltraGas boilers do not require a minimum water flow, it does not mean that the pump and burner can be switched off together when the unit is operating at full output. There should be a pump overrun to dissipate any residual heat within the boiler to avoid nuisance high temperature lockouts.

⁴ NOx emissions to EN676 are dry and at 0% excess oxygen.

• Boiler flow resistance see separate page.

• Note, from a controls point of view UltraGas D boilers are seen as two units. This means that each unit will require its own power supply and controls signals.

Technical Data

Boiler flow resistance

UltraGas® (250D,300D)

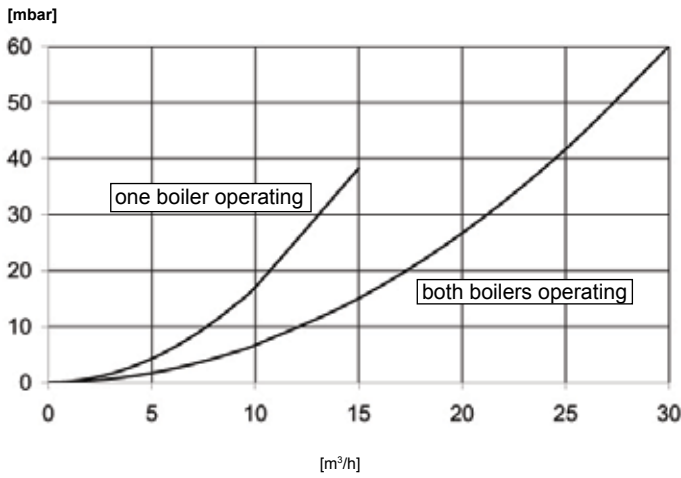

UltraGas® (400D-600D)

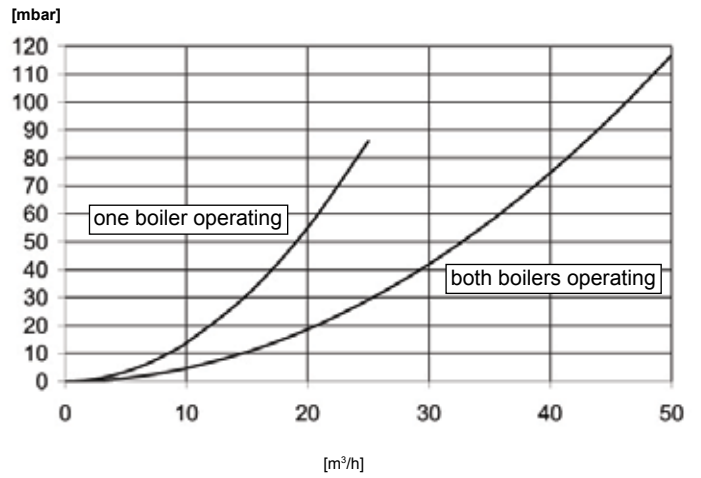

UltraGas® (700D-1000D)

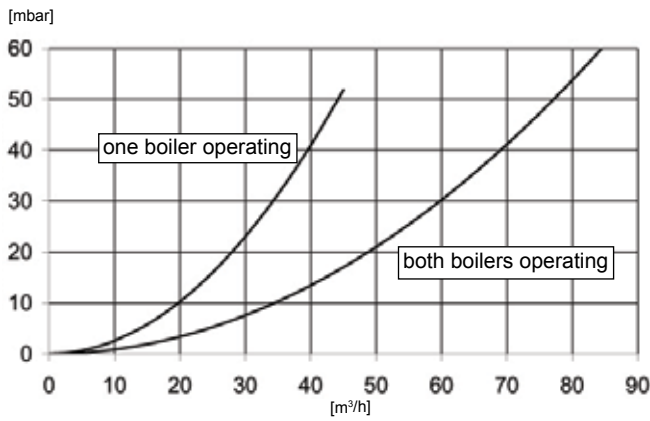

UltraGas® (1150D-1440D)

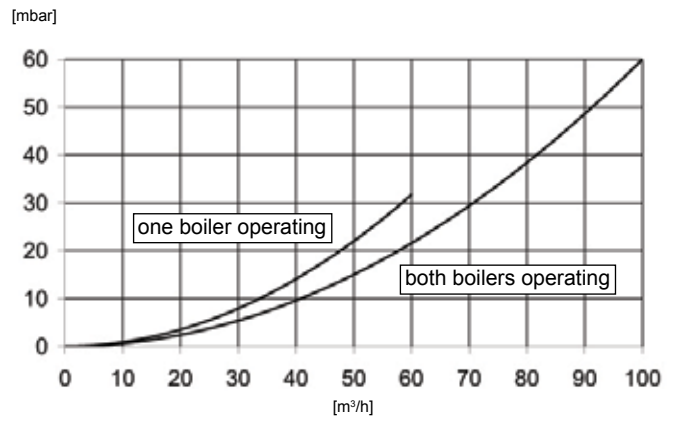

UltraGas® (2000D)

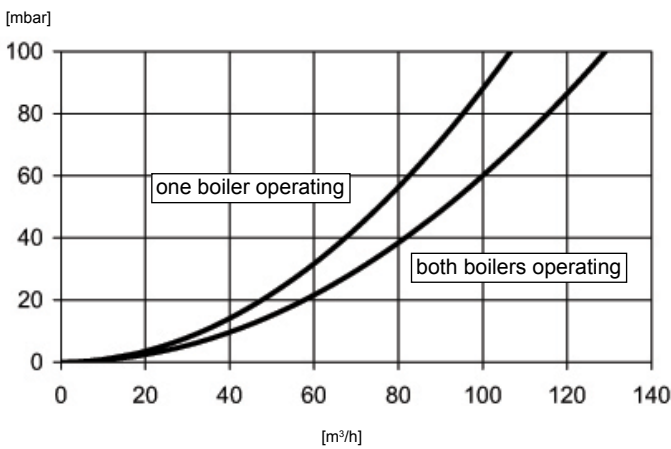

m³/h = Volume flow rate
mbar = Flow resistance

Dimensions

UltraGas® (250D-2000D)

(All measurements in mm)

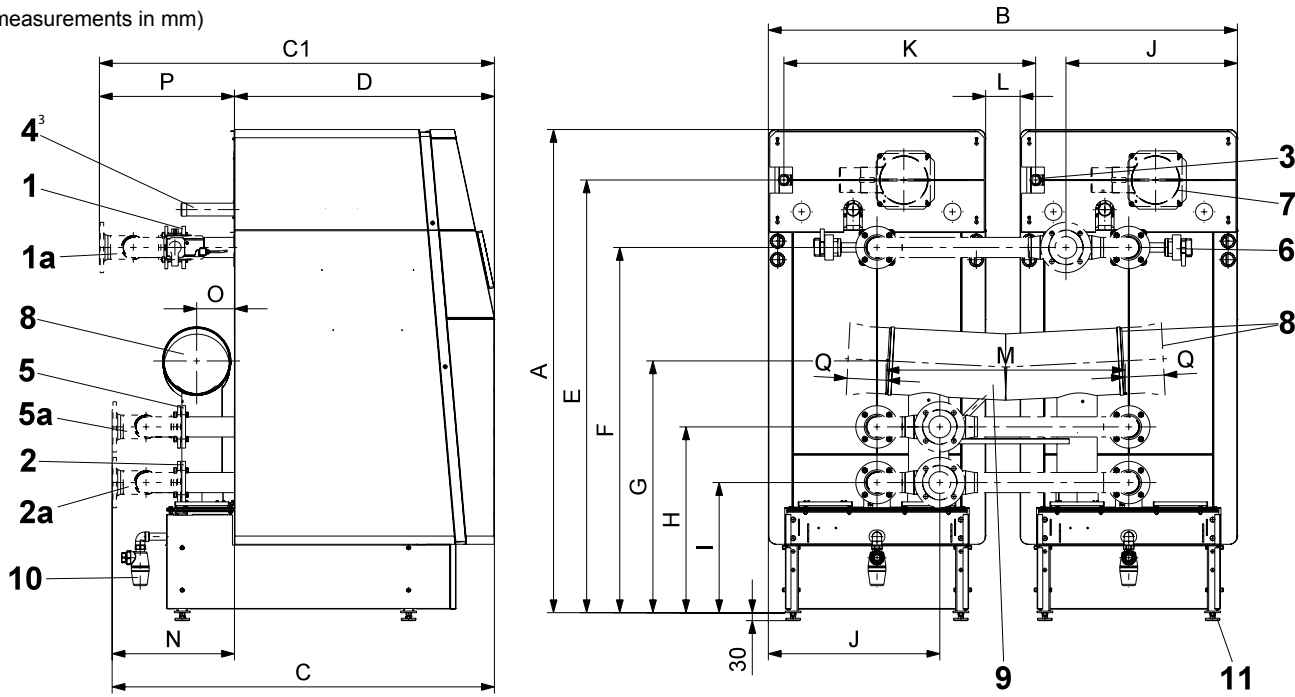

The boiler height can be reduced provided clearance is maintained for the condensate discharge trap, item 10 (gravity drain only).

UltraGas® Type	A	B	C	C1	D	E	F	G	H	I	J	K	L	M	N	O	P	Q
(250D, 300D)	1823	1770	1443	1491	981	1633	1378	944	701	491	645	950	130	902	462	143	510	-
(400D-600D)	1923	1880	1790	1758	1247	1696	1428	1023	718	498	702	950	20	930	543	173	511	-
(700D)	2070	2240	1969	1887	1268	1720	1438	1078	808	528	904	1130	20	1019	701	205	619	-
(800D-1000D)	2070	2240	1969	1887	1268	1829	1438	1078	808	528	904	1130	20	1019	701	205	619	-
(1150D-1440D)	2086	2595	2223	2283	1438	1847	1442	1093	834	554	1054	1305	15	1019	785	195	845	-
(1700D, 2000D)	2139	3120	2538	2598	1703	1888	1494	1140	858	578	1184	1570	20	1322	835	240	895	360

UltraGas® Type	(250D-300D)	(400D-600D)	(700D)	(800D-1000D)	(1150D-1440D)	(1700D-2000D)
1 Flow (Boiler).....	DN65/ PN6/4S*	DN65/ PN6/4S*	DN100/ PN6/8S*	DN100/ PN6/8S*	DN125/ PN6/8S*	DN125/ PN6/8S*
1a Flow (Optional header) ¹	DN80/ PN6/4S*	DN80/ PN6/4S*	DN125/ PN6/8S*	DN125/ PN6/8S*	DN150/ PN6/8S*	DN150/ PN6/8S*
2 Low temp return (Boiler)	DN65/ PN6/4S*	DN65/ PN6/4S*	DN100/ PN6/8S*	DN100/ PN6/8S*	DN125/ PN6/8S*	DN125/ PN6/8S*
2a Low temp return (Optional header) ¹ ..	DN80/ PN6/4S*	DN80/ PN6/4S*	DN125/ PN6/8S*	DN125/ PN6/8S*	DN150/ PN6/8S*	DN150/ PN6/8S*
3 Gas inlet.....	Rp 1"	Rp 1½"	Rp 1½"	Rp 2"	Rp 2"	Rp 2"
4 Safety valve or calorifier primary ³	R 1½"	R 1½"	R 1½"	R 1½"	R 2"	R 2"
5 High temperature return (Boiler)	DN65/ PN6/4S*	DN65/ PN6/4S*	DN100/ PN6/8S*	DN100/ PN6/8S*	DN125/ PN6/8S*	DN125/ PN6/8S*
5a High temp return (Optional header) ¹ ..	DN80/ PN6/4S*	DN80/ PN6/4S*	DN125/ PN6/8S*	DN125/ PN6/8S*	DN150/ PN6/8S*	DN150/ PN6/8S*
6 Hydraulic shut off valve (optional)						
7 Motorised air intake shut off damper	Ø104/110	Ø104/110	Ø104/110	Ø180/182	Ø180/182	Ø180/182
8 Flue gas outlet connection left or right possible ID/OD.....	Ø254/256	Ø306/308	Ø356/358	Ø356/358	Ø356/358	Ø502/506
9 Flue gas header						
10 Condensate discharge with trap.....	DN25	DN25	DN25	DN25	DN40	DN40
11 Boiler feet adjustable up to 80 mm						

¹ The connection sizes shown on this page are for the optional flow/return headers, see accessories.

² The UltraGas® (D) twin boiler consists of two boilers of half the output example UltraGas® 250D = 2 x UltraGas® 125.

Each of the two boilers requires both an electrical supply and a gas supply.

³ **AAV must be fitted before any isolation valve on each of the two boilers.**

* DN = nominal diameter , PN = nominal pressure, S = number of bolt holes in flange, example DN80/ PN6/4S

Notes

See UltraGas® (125-1000) Dimensional details page for dimensions and connection sizes¹ of individual boilers²

See separate page for installation clearances

IMPORTANT: Two loose Rp 2" fine gas filters are supplied with each of the twin UltraGas® 800D to 2000D boilers for fitting by the installer adjacent to the two boilers comprising the twin unit. Suitable isolation should be provided to facilitate routine filter pad replacement.

Dimensions

Space requirements UltraGas® (250D-2000D)

(All measurements in mm)

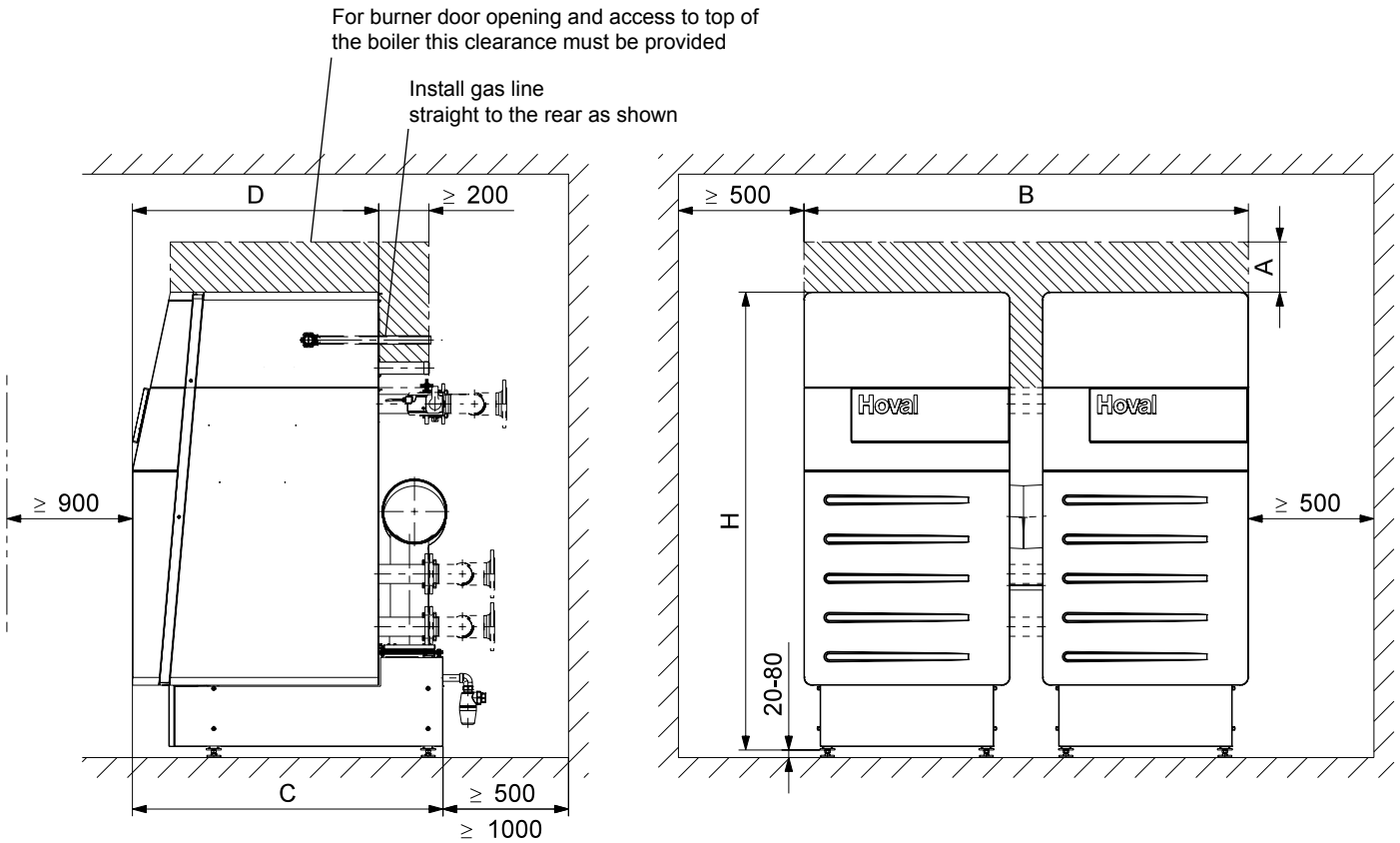

UltraGas® Type	A	A minimum	B	C	D	H	H minimum
(250D, 300D)	180 ¹	80 ²	1770	1237	981	1823	1711 ³
(400D-600D)	360 ¹	160 ²	1880	1584	1247	1923	1811 ³
(700D-1000D)	200 ¹	100 ²	2240	1679	1268	2070	1958 ³
(1150D-1440D)	200 ¹	100 ²	2595	1843	1438	2086	1984 ³
(1700D, 2000D)	420 ¹	230 ²	3120	2154	1703	2139	2037 ³

¹ If there is not sufficient room height, dimension A can be reduced to A minimum

² **Attention!** With A minimum the burner will no longer swing-open completely. This makes cleaning more difficult!

³ The boiler height can be reduced providing clearance is maintained for the condensate discharge trap. Please see page 14 for details.

⁴ If either side of the boiler has 500mm clearance the other side may be reduced to 100mm clearance.

Dimensions

Space requirements UltraGas® (250D-2000D)

(All Measurements in mm)

in addition allowance should be provided for the two RP2" fine gas filters supplied with each twin UltraGas® 800D to 2000D boiler (Part No 2007998) as follows:

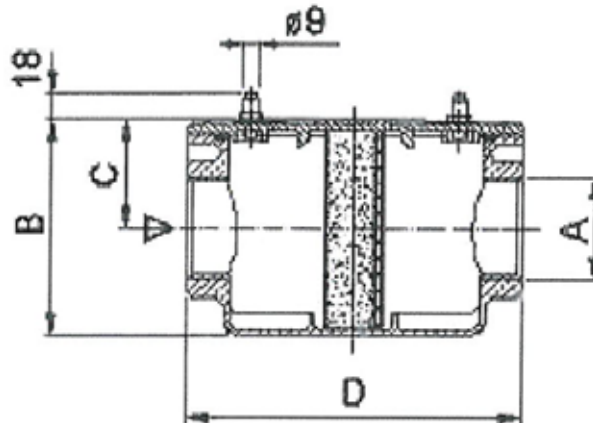

Fine gas filter installation and maintenance:

The two filters will be supplied loose for the Installer to fit adjacent to each of the two boilers comprising the twin unit. It should be possible for each gas filter to be isolated to allow the filter pad to be replaced as required (recommended to be done at least annually or when the pressure drop across the filter reaches 2.5 mbar. This can be measured across the two test points fitted on the filter top cover).

The pressure drop through a clean gas filter is as follows and needs to be taken into account by system designers along with an allowance for an increase if the filter becomes dirty:

UltraGas® 800D	(0.5 mbar)
UltraGas® 900D	(0.6 mbar)
UltraGas® 1000D	(0.8 mbar)
UltraGas® 1150D	(0.5 mbar)
UltraGas® 1300D	(0.6 mbar)
UltraGas® 1440D	(0.7 mbar)
UltraGas® 1700D	(1.0 mbar)
UltraGas® 2000D	(1.4 mbar)

For twin UltraGas® boilers the pressure drop is per individual filter

	A	B	C	D
Gas Filter	50	140	73	186

Dimensions

UltraGas® (250D-2000D) with shortened boiler feet

(All measurements in mm)

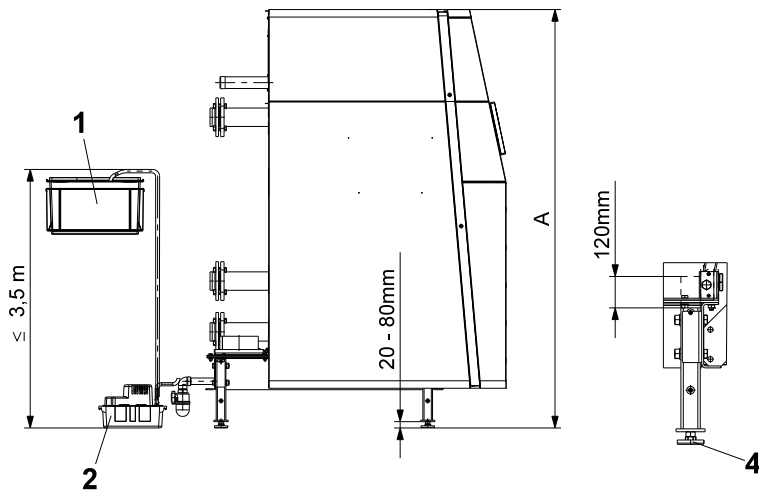

UltraGas® Type	A
(250D, 300D)	1723 - 1783
(400D - 600D)	1823 - 1883
(700D - 1000D)	1970 - 2030
(1150D - 1440D)	1986 - 2046
(1700D, 2000D)	2039 - 2099

- 1 Neutralisation box (optional)
- 2 Condensate pump (optional)
- 3 Concrete plinth (not by Hoval)
- 4 Feet adjustable from 20-80 mm

UltraGas® (250D-2000D) with concrete plinth and adjustable feet

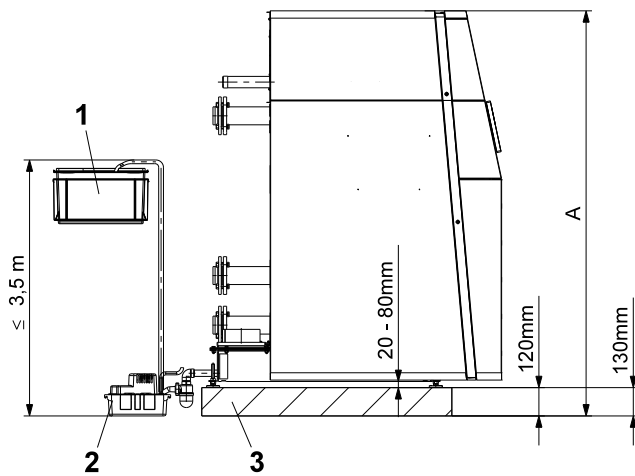

UltraGas® Type	A
(250D, 300D)	1711 - 1771
(400D - 600D)	1811 - 1871
(700D - 1000D)	1958 - 2018
(1150D - 1440D)	1984 - 2044
(1700D, 2000D)	2037 - 2097

UltraGas® with concrete plinth without adjustable feet

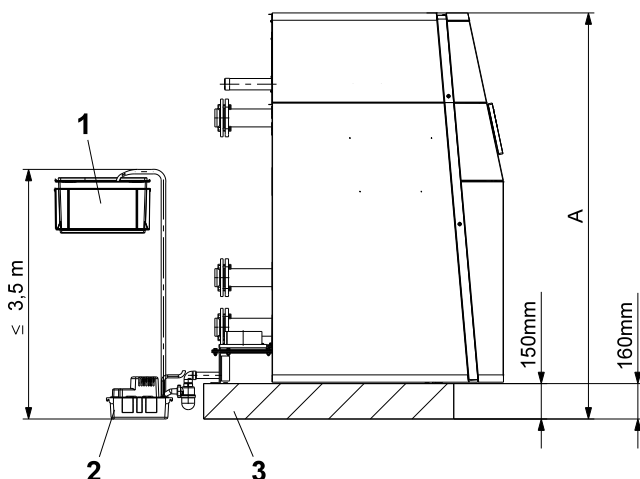

UltraGas® Type	A
(250D, 300D)	1721
(400D - 600D)	1821
(700D - 1000D)	1968
(1150D - 1440D)	1994
(1700D, 2000D)	2047

Un-used boiler feet cannot be returned to Hoval for a refund.

Flue System / Ventilation

Flue design UltraGas® (125-2000D)

- A minimum temperature class T120 flue can be used if fitted with an over temperature device.
- The first 2 metres of flue gas pipe must be the same diameter as the boiler flue gas connection.
- Single wall flues may be used as it is not necessary to keep the flue gas temperature high.
- The flue gas is very cool and saturated with moisture so there will be very little or no buoyancy to pull the gases up the chimney.
- The burner fan assists with the evacuation of the flue gases so there may be slight pressurisation of the flue.
- Flues must be leak proof against condensate and suitable for pressurised flue gases.
- It is permissible for the condensate from the flue system to drain back through the boiler.
- Horizontal flue sections must be inclined back to the boiler (3° minimum) to prevent condensate remaining in the flue.
- If combustion air ducting is used this should be the same size as the flue.
- Flues must be designed to meet all current regulations / standards.
- **On installations with multiple boilers into a single flue the flue system must be designed to prevent any back circulation of flue gases into the plant room (fitting air shut off dampers enable this criteria to be easily met - see accessories).**
- See Technical data section for flue gas mass flow rates, temperatures and usable fan overpressure.
- The tables below are for guidance only.

Type	Boiler	Flue size (smooth walled)			Number of 90° bends (flue + air supply)				
	Flue gas connection (mm)	Dimension	Flue (mm)		Maximum total length in metres (flue + air supply)				
UltraGas®	internal	DN	outside	inside	1	2	3	4	5 *
(125)	155	130	130	127	24	23	22	21	
(150)	155				15	14	13	12	
(125)	155	150	150	147	44	44	44	44	
(150)	155				44	44	44	44	
(200)	252				24	24	23	22	
(250)	252				12	12	11	11	
(125)	155	175	177	175	50	50	50	50	
(150)	155				50	50	50	50	
(200)	252				50	50	50	50	
(250)	252				46	45	45	44	
(200)	252	200	202	200	50	50	50	50	
(250)	252				50	50	50	50	
(300)	252				50	50	50	50	
(350)	302				42	41	40	39	
(250-300)	252	250	252	250	50	50	50	50	
(350-500)	302				50	50	50	50	
(350-720)	302	300	302	300	50	50	50	50	
(850)	402	350	352	350	50	50	50	50	
(850-1000)	402	400	402	400	50	50	50	50	
(250D)	254	200	202	200	50	50	48	45	
(300D)	254				35	33	30	27	
(250D-300D)	254	250	252	250	50	50	50	50	
(400D)	306				50	50	50	50	
(500D)	306				38	35	32	29	
(400D-600D)	306	300	302	300	50	50	50	50	
(700D)	356				50	50	50	50	
(800D)	356				45	40	35	31	
(900D)	356				32	27	22	17	
(1000D)	356				26	21	15	12	
(700D-900D)	356	350	352	350	50	50	50	50	
(1000D)	356				50	50	50	42	
(1150D)	356				35	25	14	–	
(1300D)	356				17	6	–	–	
(1150D-1300D)	356	400	402	400	50	50	50	50	
(1440D)	356				50	50	50	42	
(1700D-2000D)	500	500	502	500	50	50	50	50	

Figures are based on the flue entering the vertical at 90°, for 45° entry or if 45° bends are used longer flue lengths may be possible.

* With 5 bends or more the usable overpressure of the fan must be reduced by 30% and a flue calculation done.

With flue lengths over 50 metres a separate calculation must be done.

Ventilation

For installations **not exceeding 70kW** total nominal input (net) refer to **BS5440-2:current edition**.

For installations **over 70kW** total nominal input (net) both high and low level or mechanical ventilation is required, calculate to **BS6644:current edition**.

Accessories

100/150PP Concentric flue parts for UltraGas® 70, 100

Part No.

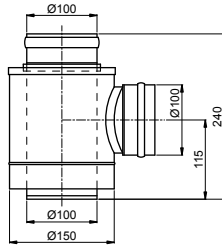

Connection C100/150 to 2xE100PP
For separate routing of flue gases and
combustion air.

Recommendation:
If the air inlet is near a noise sensitive
place (window of bedroom, terrace etc.) we
recommend the use of a sound absorber on
the air inlet.

2015 244

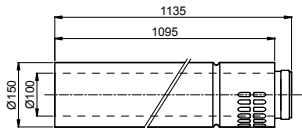

Wall terminal for horizontal discharge

202 2405

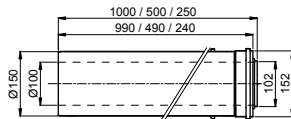

1000mm extension
(including support bracket)
500mm extension
(including support bracket)
250mm extension

204 2409

204 2408

204 2407

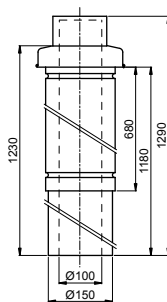

Vertical terminal (black) with cap
(including support bracket)

204 2404

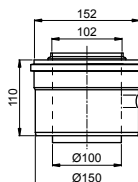

Vertical adaptor
Complete with 2 sample points.

204 2406

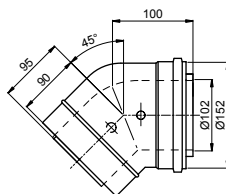

45 degree elbow

204 2411

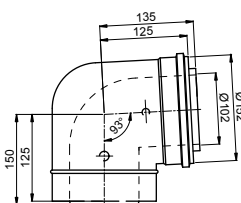

93 degree elbow

204 2410

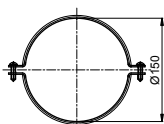

Support bracket

204 2414

Accessories

100/150PP Concentric flue parts for UltraGas® 70, 100

Part No.

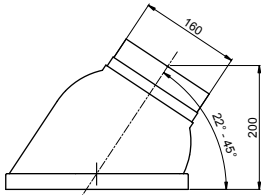

Lead pitched roof flashing
(to suit roof angle 25-45 degrees)

204 2412

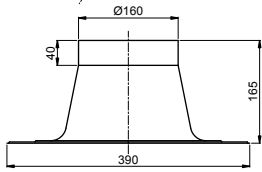

Aluminium flat roof flashing

204 2413

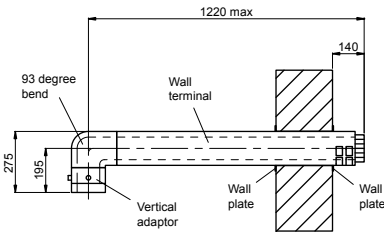

Wall terminal kit (for horizontal discharge)
Comprises of vertical adaptor, 93 degree
elbow and 2 wall plates. Max dimension can
be extended by use of extension pieces.

204 2405

All items finished white RAL 9016.

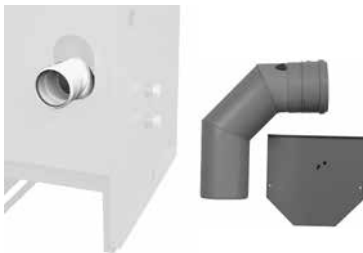

Horizontal flue gas connection adaptor
E100PP for UltraGas® (70, 100)

6016 933



Adaptor to convert horizontal flue gas
connection (above) to concentric. Includes air
tube for connection to venturi.

75mm dia for UltraGas® (70)

6017 288

Accessories

Accessories for Heating regulator TopTronic®T

Part No.

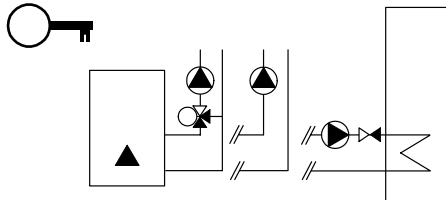
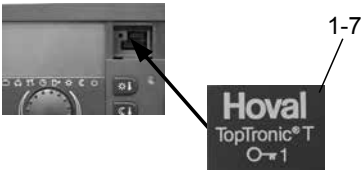

Key-Module for Hoval TopTronic®T for additional functions.
Key-Modul consists of:
Function key for plugging into TopTronic®T with necessary sensors and electrical connections.

Only one Key-Module is possible per TopTronic®T.

Standard functions already included in TopTronic®T.
- 1 mixing circuit
- 1 heating circuit without mixing operation
- Domestic hot water loading circuit

Functions of Key-Modules:
Key-Module 2 mixing circuits solid fuel buffer vessel Solar

Key-Module	2 mixing circuits	solid fuel buffer vessel	Solar
①	●		
②		●	
③			●
④	●	●	
⑤	●		●
⑥		●	●
⑦	●	●	●

+ ①

+ ②

+ ③

+ ④

+ ⑤

+ ⑥

+ ⑦

Key-Module 1
For 2 mixing circuits.
Function key 1, 1 flow sensor, 2 loose plugs.

6012 154

Key-Module 2
For solid fuel / buffer vessel installation.
Function key 2, 3 immersion sensors, 4 loose plugs.

6012 155

Key-Module 3
For solar plants.
Function key 3, 1 collector panel sensor, 1 calorifier sensor, 4 loose plugs.

6012 156

Key-Module 4
For 2 mixing circuits and solid fuel / buffer vessel installation.
Function key 4, 1 flow sensor, 3 immersion sensors, 6 loose plugs.

6012 157

Key-Module 5
For 2 mixing circuits and solar plants.
Function key 5, 1 flow sensor, 1 collector panel sensor, 1 calorifier sensor, 6 loose plugs.

6012 158

Key-Module 6
For solid fuel / buffer vessel installation and solar plants.
Function key 6, 1 collector panel sensor, 4 immersion sensors, 6 loose plugs.

6012 159

Key-Module 7
For 2 mixing circuits, solid fuel / buffer vessel installation and solar plants.
Function key 7, 1 flow sensor, 1 collector panel sensor, 4 immersion sensors, 8 loose plugs.

6012 160

Sensor type
Immersion / calorifier sensor: TypeKVT20/5/6 (L = 5m) without immersion sleeve.
flow sensor : Type VF204S with plug
collector sensor : Type PT1000 (Silicon)

Consult Hoval for specific applications

Accessories

Accessories for Heating regulator TopTronic®T

Part No.



Room station RS-T
For remote control of circuits. Includes room sensor, information and advanced program keys.

2034 939



Remote control RFF-T
For simple remote control of circuits. Includes room sensor, simple program keys and temperature adjustment.

2022 239



Additional outdoor sensor AF 200
For one mixing circuit or for average value (2 outdoor temperature sensors possible per TopTronic®).

2022 995



Immersion sensor KVT 20/5/6S
With 5m cable and plug (excludes pocket).

6012 687



Surface temperature sensor VF204S
Usable as flow or return sensor with 4m cable and plug.

6012 688

Flow temperature limit thermostats

For underfloor heating (1 per heating circuit)
15-95°C, differential 6K.



Clamp-on thermostat RAK-TW1000.S
Thermostat with strap, without cable and plug.

242 902



Clamp-on thermostat RAK-TW1000.S
Thermostat with strap, 4m long cable and plug.

6015 000

Immersion thermostat RAK-TW1000.S SB 150
Thermostat with brass nickel-plated ½" pocket x 150mm long.

6010 082

Additional heating regulator set ZN1

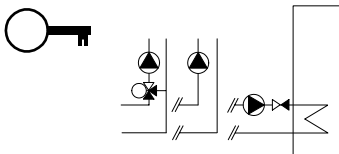

Can be installed as supplement for boiler control TopTronic®T/U4.1 on UltraGas® 70kW and above (external TopTronic® required on UltraGas® 15-50 see overleaf).

For extending functionality and implementing further heating circuits. Consists of:

- Heating regulator Hoval TopTronic®T/N for
- 1 mixer circuit
- 1 heating circuit without mixer operation
- Domestic hot water loading circuit
- Flow Sensor VF202K with 2m cable and plug
- Cable set for connecting the auxiliary heating regulator TopTronic®T/ N with the boiler control

6020 574



Accessories

External TopTronic®T

Part No.



- Heating regulator Hoval TopTronic®T/N
- 1 mixer circuit
 - 1 heating circuit without mixing operation
 - Domestic hot water loading circuit

2022 223



- Control panel WG1
- Plastic casing with clear cover
 - Light grey
 - 6.3 amp fuse and terminals
 - 365mm x 320mm x 160mm

6012 598

or



- Control panel MSK
- Plastic casing
 - Dark grey
 - 281mm x 94mm x 93mm

6012 508

BMS module



- BMS Module 0-10V GLT
Module for control of boiler by a building management system using 0-10 V signals.
- For the control of firing rate or setpoint and interrogation of firing rate or setpoint (single boiler).
 - For the control of setpoint only and interrogation of firing rate and setpoint on first boiler (a single BMS Module 0-10V GLT is required with up to five boilers sequenced by TopTronic).
 - For the control of setpoint only and interrogation of firing rates and setpoints on individual boilers (BMS Module 0-10V GLT is required per boiler with up to five boilers sequenced by TopTronic).

Consisting of: BMS-Module and transformer.

6015 195



- External casing SB-GE required for UltraGas® 15-50 (only) to accommodate the 0-10V module above. For all larger models this module can be fitted in the boiler control panel.
- Light grey
 - 250mm x 175mm x 100mm

6013 063



- BMS Module - MODBUS
Module for control of boiler by a building management system using modbus protocol.
- For the control of firing rate or setpoint and interrogation of various parameters (single boiler).
 - For the control of setpoint only and interrogation of various parameters on up to five boilers (a single BMS Module MODBUS is required with up to five boilers sequenced by TopTronic).

6014 389

Liquid gas conversion

Liquid gas conversion kits

- | | |
|---------------------|----------|
| UltraGas® 15 - 70 | 619 568 |
| UltraGas® 100 | 6015 663 |
| UltraGas® 400 - 500 | 6015 473 |
| UltraGas® 575 - 720 | 6015 474 |

For operation with liquid gas on the 125 - 350 and 850 - 1000 models please refer to the conversion details in the manual.

Accessories



*supplied as standard with UltraGas® 400-100 and UltraGas® 800D-2000D

Fine gas filter

with pressure test point before and after the filter (diameter: 9mm)

Pore width of the filter element <50 µm

Max. pressure difference 2.5 mbar

Max. inlet pressure 100 mbar

Type	Connection	Part No.
70612/6B	Rp 3/4"	2007 995
70602/6B	Rp 1"	2007 996
70604/6B	Rp 1 1/4"	2054 495
70603/6B	Rp 1 1/2"	2007 997
70631/6B	Rp 2"	*2007 998

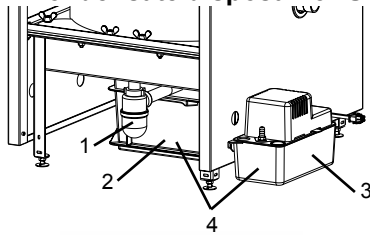
Part No.**Condensate disposal for UltraGas® 15-100**

Possible mounting variations for neutralisation:

- 1 without neutralisation (siphon supplied).
- 2 with neutralisation box under the boiler.
- 3 with condensate pump next to the boiler.
- 4 with neutralisation box under the boiler and with condensate pump next to the boiler.

**Neutralisation box**

For transporting condensate via gravity. Including condensate neutraliser. To be installed in the boiler base.

6012 553

**Condensate pump**

For pumped condensate delivery. Including connecting wiring, cable and plug for connection to the boiler control. Installation on the left or right beside the boiler.

6015 159

Neutralisation granulate for neutralisation box

Refill set of granulate for neutralisation, volume 3 kg (12 kg required per neutralisation box).

2028 906

Condensate disposal for UltraGas® 125-1000

Neutralisation box placed under the boiler

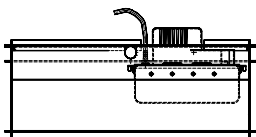
**Type KB 22**

For pumped condensate delivery.
- condensate pump and float switch included
- without neutralisation granulate

6015 160

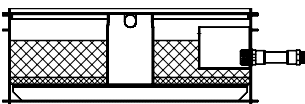
**Type KB 23**

For condensate drainage via gravity.
- with 12 kg neutralisation granulate

6001 917

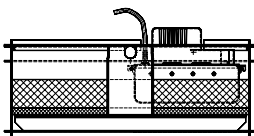
**Type KB 24**

For pumped condensate delivery.
- condensate pump and float switch included
- with 12 kg neutralisation granulate

6001 918

**Condensate pump**

For pumped condensate delivery. Including connecting wiring, cable and plug for connection to the boiler control.

6015 159

Neutralisation granulate for neutralisation box

Refill set of granulate for neutralisation, volume 3 kg (12 kg required per neutralisation box).

2028 906

Accessories

Air inlet connection for UltraGas® 125-1000

Part No.

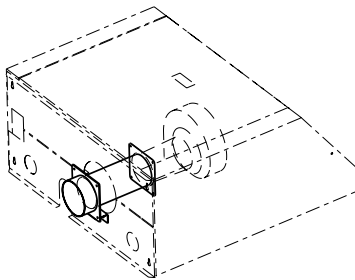

Connection for direct combustion air inlet

UltraGas® 125-150	6018 903
UltraGas® 200-300	6018 904
UltraGas® 350	6018 905
UltraGas® 400-500	6018 906
UltraGas® 575-720	6012 476
UltraGas® 850	tba
UltraGas® 1000	tba

Recommendation:

If the air inlet is near a noise sensitive place (window of bedroom, terrace etc.) we recommend the use of a sound absorber on the air inlet.

Not required if air shut off valve fitted

Air shut off damper for UltraGas® 125-1000



Motorised air intake shut off damper

Connector for direct combustion air supply with motorised flaps. Can also be used for cascading boiler systems with a common flue arrangement. Complete with cabling.

UltraGas® 125-350 DN 110	6015 196
UltraGas® 400-1000 DN 180	6015 197

Fitted as standard on 250D-2000D

Twin boiler hydraulic header sets for UltraGas® 250D-2000D

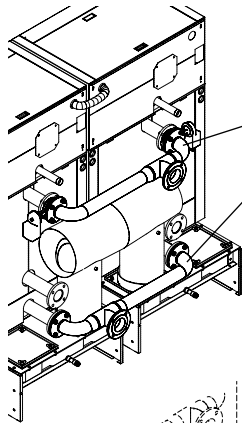

Flow/Return

Hydraulic header set for twin boiler including motorised shut off valve.

UltraGas® 250D - 600D	6002 015
UltraGas® 700D - 1000D	6005 656
UltraGas® 1150D - 1440D	6012 333
UltraGas® 1700D - 2000D	6020 273

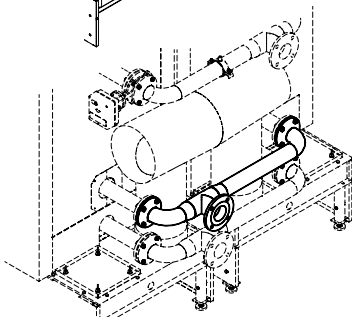

High temperature return

Hydraulic header set for twin boiler (can also be used as flow header if motorised shut off valves not required).

UltraGas® 250D - 600D	6001 926
UltraGas® 700D - 1000D	6004 924
UltraGas® 1150D - 1440D	6009 534
UltraGas® 1700D - 2000D	6020 274

Hydraulic shut off valves for UltraGas® 125-2000D



Hydraulic shut off valve

Installed directly onto flow and or return when no flow/return set has been ordered. Complete with plugs and cabling.

Two valves required per twin boiler

UltraGas® 125-300	1 piece DN65	6002 660
UltraGas® 350-500 and H500	1 piece DN100	6005 813
UltraGas® 575-1000 and H720	1 piece DN125	6012 324

Accessories

Boiler-Connection set for UltraGas® 15-100

Part No.

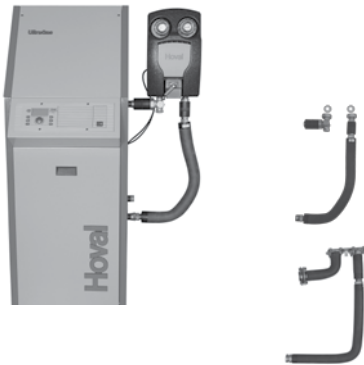

For the installation of a heating circuit set on the Hoval UltraGas® 15-100. Suitable for left hand or right hand installation. Rigid flow pipe and flexible return. Fully insulated and complete with fittings

AS25-S/NT/ HT low or high temperature return
Suitable for set HA25 on UltraGas® 15-27. 6017 055

AS32-S/NT/ HT low or high temperature return
Suitable for set HA32 on UltraGas® 35-50. 6014 846

AS40-S/NT/ HT low or high temperature return
Suitable for set HA40 on UltraGas® 70-100. (for heating circuit set HA32 adaptor set DN32-40 is required) 6014 848

Adaptor set DN32-DN40 for attaching heating circuit HA32 to connection set AS40 6014 863

Adapter set DN32-DN25 for attaching heating circuit HA32 to connection set AS25 6007 191

Adapter set DN20-DN25 for attaching heating circuit HA20 to connection set AS25 6013 693

Heating circuit set type HA-3BM-R (Right hand side version)
Complete with three-way mixing valve and thermally insulated box.

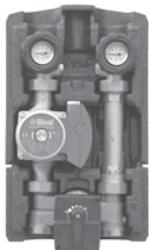

HCS type	pump type		
DN20(3/4")	HA20-3BM-R/MX10-4	MX10-4/230 V	6019 273
	HA20-3BM-R/MX12-4	MX12-4/230 V	6019 274
	HA20-3BM-R/AX12-4	AX12-4/230 V	6020 519
DN25(1")	HA25-3BM-R/MX12-1	MX12-1/230 V	6019 275
	HA25-3BM-R/MX13-1	MX13-1/230 V	6019 276
	HA25-3BM-R/AX12-1	AX12-1/230 V	6020 520
DN32(1 1/4")	HA25-3BM-R/AX13-1	AX13-1/230 V	6020 521
	HA32-3BM-R/MX13-2	MX13-2/230 V	6019 280
	HA32-3BM-R/M14-2	M14-2/230 V	6019 281
DN40(1 1/2")	HA32-3BM-R/AX13-2	AX13-2/230 V	6020 522
	HA40-3M-R	No Pump	6014 867

Heating circuit set type HA-3BM-L (Left hand side version)
Complete with three-way mixing valve and thermally insulated box.



HCS type	pump type		
DN20(3/4")	HA20-3BM-L/MX10-4	MX10-4/230 V	6019 288
	HA20-3BM-L/MX12-4	MX12-4/230 V	6019 289
	HA20-3BM-L/AX12-4	AX12-4/230 V	6020 523
DN25(1")	HA25-3BM-L/MX12-1	MX12-1/230 V	6019 290
	HA25-3BM-L/MX13-1	MX13-1/230 V	6019 291
	HA25-3BM-L/AX12-1	AX12-1/230 V	6020 524
DN32(1 1/4")	HA25-3BM-L/AX13-1	AX13-1/230 V	6020 525
	HA32-3BM-L/MX13-2	MX13-2/230 V	6019 294
	HA32-3BM-L/M14-2	M14-2/230 V	6019 295
	HA32-3BM-L/AX13-2	AX13-2/230 V	6020 526

Circuit set type LG-2 for free standing CombiVal calorifier.
Complete with thermally insulated box.

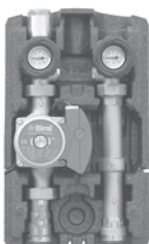

HCS type	pump type		
DN20(3/4")	LG/HA20-2/MX12-4	MX12-4/230 V	6019 283
	LG/HA20-2/AX12-4	AX12-4/230 V	6020 527
DN25(1")	LG/HA25-2/MX12-1	MX12-1/230 V	6019 284
	LG/HA25-2/MX13-1	MX13-1/230 V	6019 285
	LG/HA25-2/AX12-1	AX12-1/230 V	6020 528
DN32(1 1/4")	LG/HA25-2/AX13-1	AX13-1/230 V	6020 529
	LG/HA32-2/MX13-2	MX13-2/230 V	6019 287
	LG/HA25-2/AX13-2	AX13-2/230 V	6020 530

Accessories

UltraGas® (15-100) accessories

Part No.

**Wall brackets**

for mounting a Hoval heating circuit set.

Type	A mm	connection	
		top	bottom
DN 20	90	Rp 1	R ¾"
DN 25	125	Rp 1½"	R 1

6019 209

6019 210

**Safety set**complete with safety valve set at 3 bar lift, pressure gauge and automatic air vent
Connection: internal thread

DN15 for UltraGas® (15-50)

641 184

DN20 for UltraGas® (70,100)

6014 390

Motorised mixing valves



Type H3G/NR 230-20 B, PN 6, 110°C

Three-way valve made of cast iron

Connections with internal thread.

- Motorized 230 V
- 3 wire control

DN	kvs ¹
¾"	8
1"	12
1 ¼"	18
1 ½"	28
2"	44

¾"

8

6003 894

1"

12

6003 895

1 ¼"

18

6003 896

1 ½"

28

6003 897

2"

44

6003 898



Type H3F/NR 230-20 B, PN 6, 110°C

Three-way valve made of cast iron

Without counter flanges.

- motorized 230 V
- 3 wire control

DN	kvs ¹
40	44
50	66
65	100
80	150

40

44

6003 904

50

66

6003 905

65

100

6003 906

80

150

6003 907



NR230-20 B actuator

245 209

¹ Flow quantity in m³/h on a pressure loss of 1 bar.

Larger sizes of motorised valves are available on request

Typical hydraulic schematics

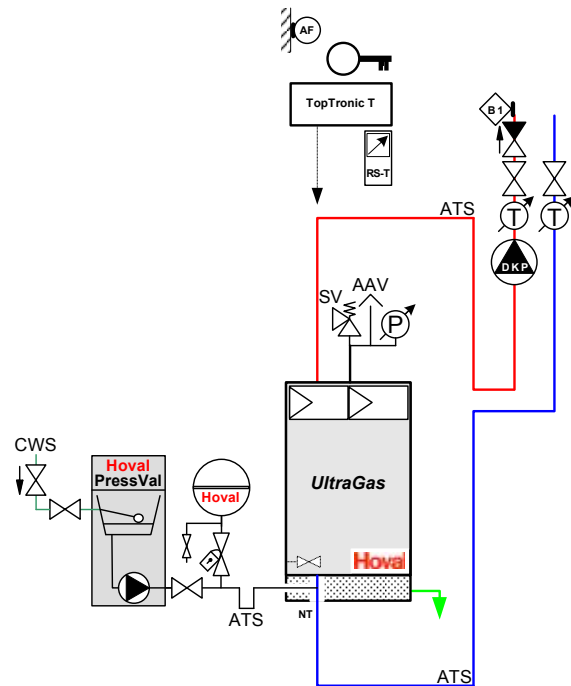
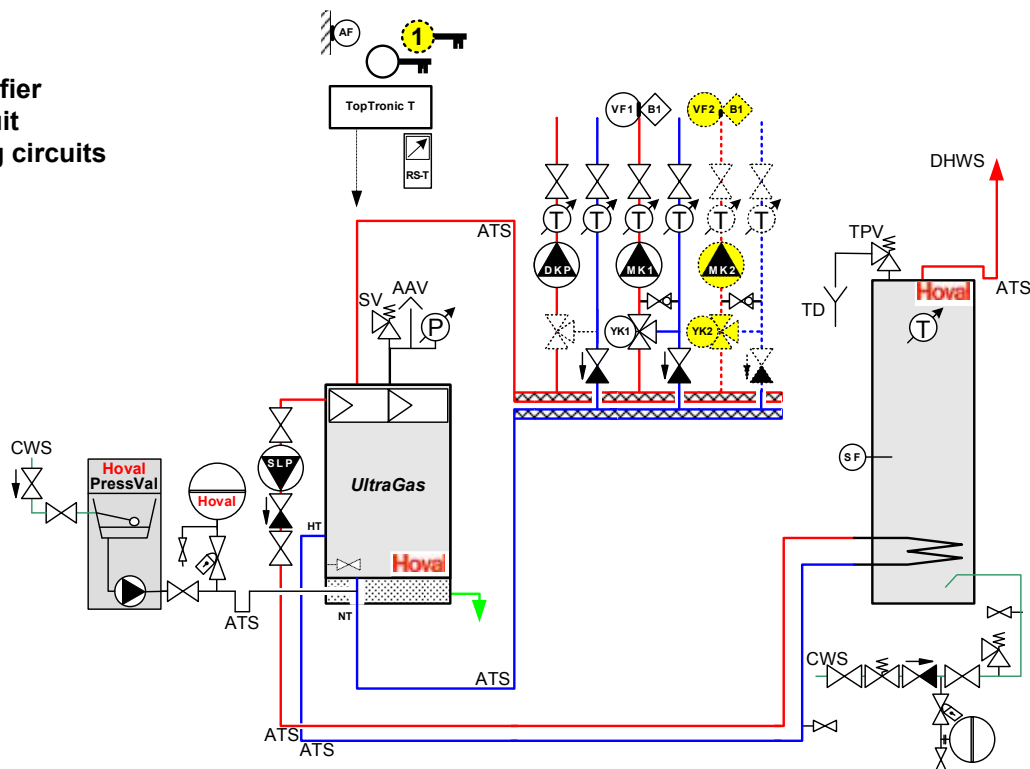
UltraGas® boiler with
- Direct heating circuit

UltraGas® boiler with
- Free standing calorifier
- Direct heating circuit
- 1 or 2 mixed heating circuits

Notice :

- This hydraulic schematic just shows the basic principle. The installation must be in accordance with local regulations.
- With underfloor heating an over temperature thermostat has to be installed.
- Anti thermal siphon dip has to be installed.
- up to five boilers can be linked together to provide sequence control

RS-T	Room station	MK1	Pump mixed circuit 1
AF	Outdoor sensor	MK2	Pump mixed circuit 2
VF1	Flow sensor 1	DKP	Pump for heating circuit without mixing operation
VF2	Flow sensor 2	SLP	Calorifier loading pump
SF	Calorifier sensor	YK1	Actuator mixer 1
B1	Flow temperature thermostat (series connection with pump)	YK2	Actuator mixer 2
TPV	Temperature and pressure relief valve	HT	High temperature return
TD	Tundish to drain	NT	Low temperature return
SV	Safety Valve	ATS	Anti-thermal siphon dip to prevent gravity circulation
AAV	Automatic air vent		

Typical hydraulic schematics

UltraGas® boiler with

- Solar free standing calorifier
- a direct heating circuit
- 1 or 2 mixed heating circuits

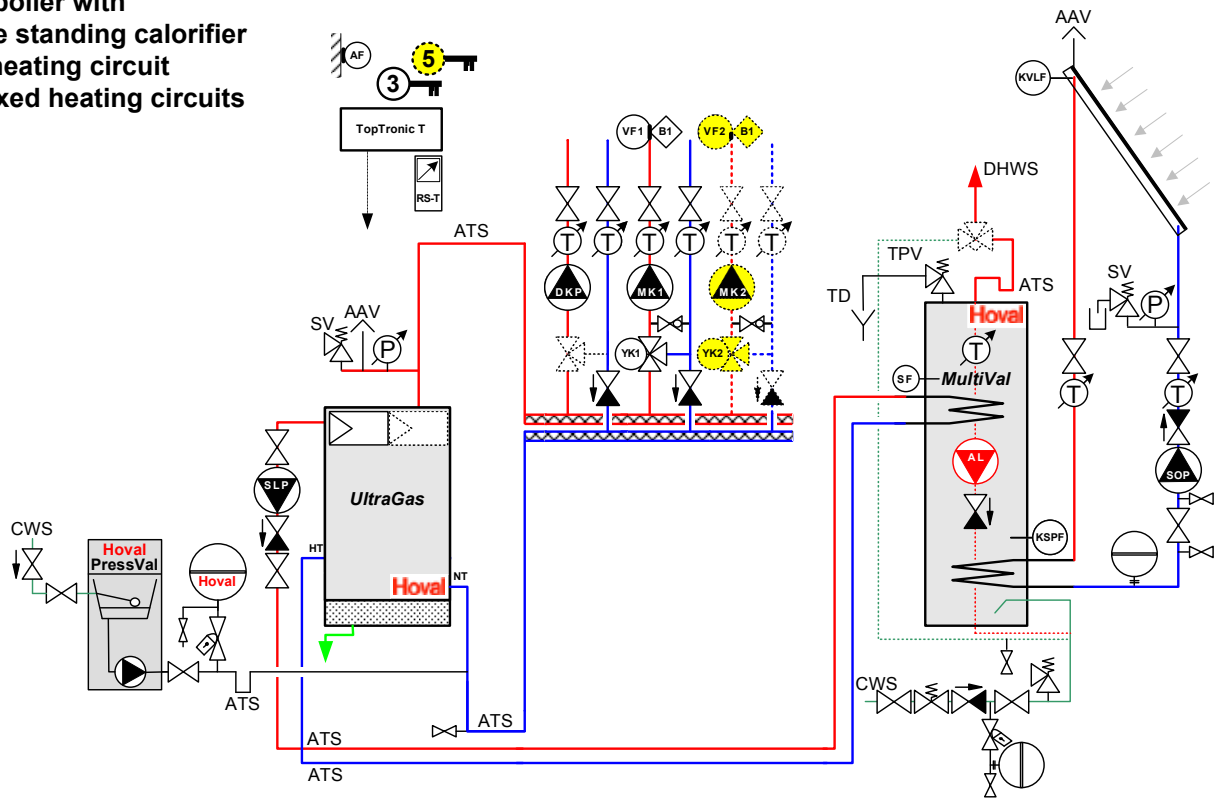

UltraGas® boiler with

- Free standing calorifier
- Return flow separation
- 1 mixed heating circuit (high temperature return)
- 1 mixed heating circuit (low temperature return)

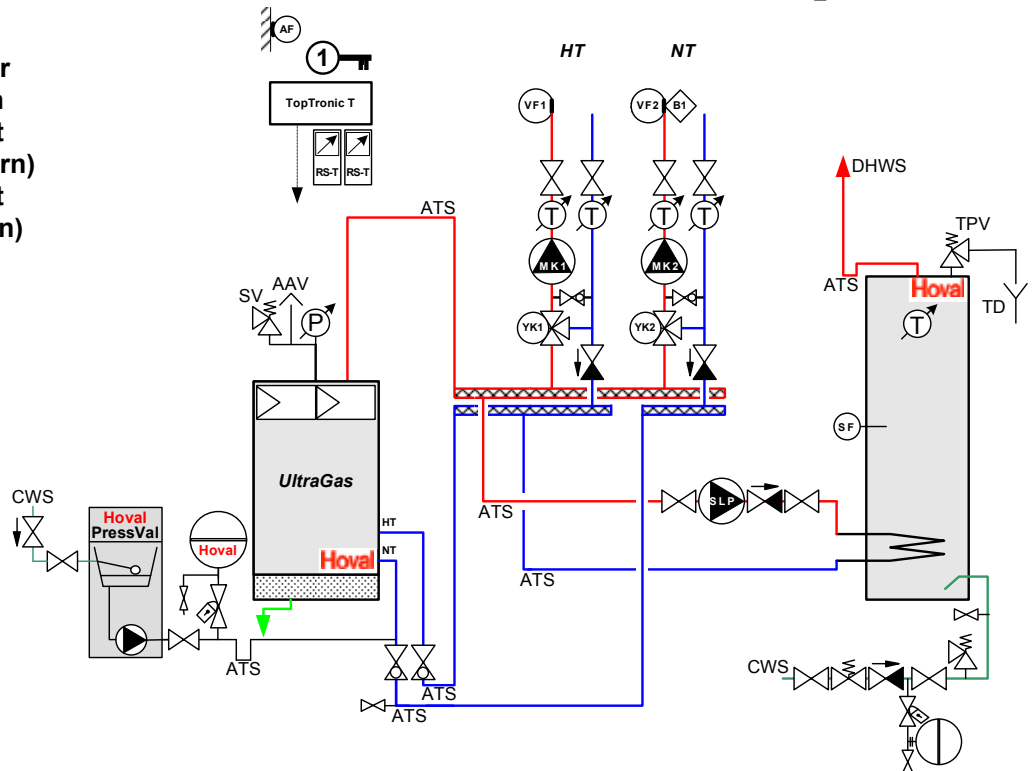

Notice :

- This hydraulic schematic just shows the basic principle. The installation must be in accordance with local regulations.
- With underfloor heating an over temperature thermostat has to be installed.
- Anti thermal siphon dip has to be installed.
- up to five boilers can be linked together to provide sequence control

RS-T	Room station
AF	Outdoor sensor
VF1	Flow sensor 1
VF2	Flow sensor 2
SF	Calorifier sensor
B1	Flow temperature thermostat (series connection with pump)
MK1	Pump mixed circuit 1
MK2	Pump mixed circuit 2
SLP	Calorifier loading pump
SOP	Solar circulation pump
KSPF	Solar tank sensor (calorifier/ buffer)
KVLF	Solar panel flow sensor (PT1000)

YK1	Actuator mixer 1
YK2	Actuator mixer 2
T1	Differential control sensor 1
T2	Differential control sensor 2
T3	Differential control sensor 3
HT	High temperature return
NT	Low temperature return
ATS	Anti-thermal siphon dip to prevent gravity circulation
TPV	Temperature and pressure relief valve
TD	Tundish to drain
SV	Safety Valve
AAV	Automatic air vent

Typical hydraulic schematics

UltraGas® boiler with

- Solar free standing calorifier
- a direct heating circuit
- 1 or 2 mixed heating circuits

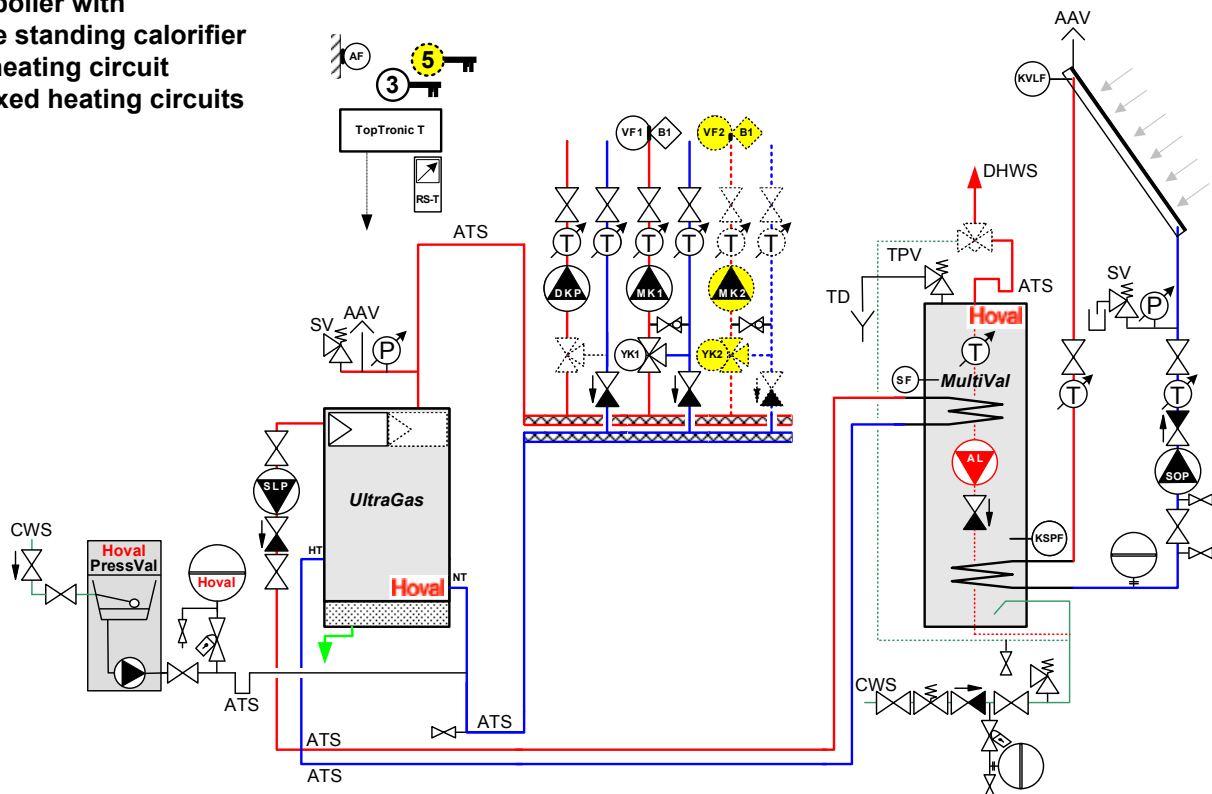

UltraGas® boiler with

- Free standing calorifier
- Return flow separation
- 1 mixed heating circuit (high temperature return)
- 1 mixed heating circuit (low temperature return)

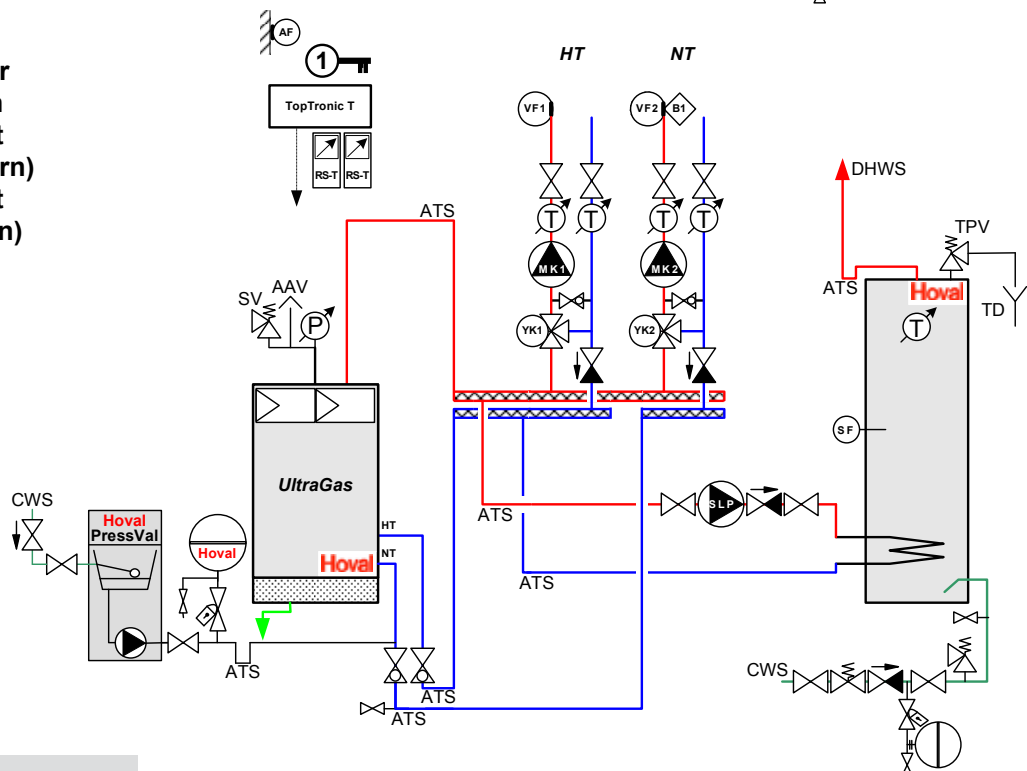

Notice :

- This hydraulic schematic just shows the basic principle. The installation must be in accordance with local regulations.
- With underfloor heating an over temperature thermostat has to be installed.
- Anti thermal siphon dip has to be installed.
- up to five boilers can be linked together to provide sequence control

RS-T	Room station	YK1	Actuator mixer 1
AF	Outdoor sensor	YK2	Actuator mixer 2
VF1	Flow sensor 1	T1	Differential control sensor 1
VF2	Flow sensor 2	T2	Differential control sensor 2
SF	Calorifier sensor	T3	Differential control sensor 3
B1	Flow temperature thermostat (series connection with pump)	HT	High temperature return
MK1	Pump mixed circuit 1	NT	Low temperature return
MK2	Pump mixed circuit 2	ATS	Anti-thermal siphon dip to prevent gravity circulation
SLP	Calorifier loading pump	TPV	Temperature and pressure relief valve
SOP	Solar circulation pump	TD	Tundish to drain
KSPF	Solar tank sensor (calorifier/ buffer)	SV	Safety Valve
KVLF	Solar panel flow sensor (PT1000)	AAV	Automatic air vent

Typical hydraulic schematics / Hoval Service

UltraGas® boiler with
 - free standing calorifier
 - 4 mixed heating circuits

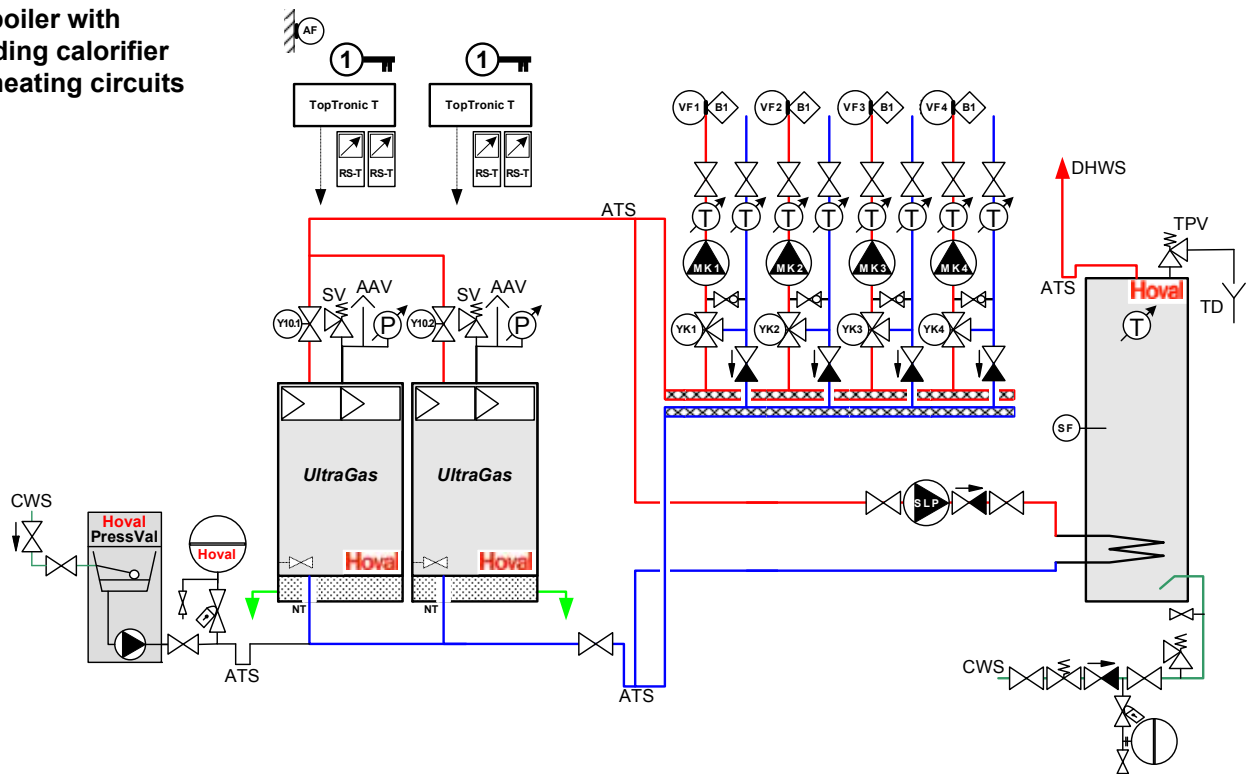

- | | |
|---|---|
| RS-T Room station | KKP1 Boiler circuit pump 1 |
| AF Outdoor sensor | KKP2 Boiler circuit pump 2 |
| VF1 Flow sensor 1 | SLP Calorifier loading pump |
| VF2 Flow sensor 2 | YK1 Actuator mixer 1 |
| VF3 Flow sensor 3 | YK2 Actuator mixer 2 |
| VF4 Flow sensor 4 | YK3 Actuator mixer 3 |
| SF Calorifier sensor | YK4 Actuator mixer 4 |
| B1 Flow temperature thermostat
(series connection with pump) | Y10.1 valve 1 or zone valve
(Single wire system) |
| MK1 Pump mixed circuit 1 | Y10.2 valve 2 or zone valve
(Single wire system) |
| MK2 Pump mixed circuit 2 | ATS Anti-thermal siphon dip to prevent
gravity circulation |
| MK3 Pump mixed circuit 3 | TPV Temperature and pressure relief valve |
| MK4 Pump mixed circuit 4 | TD Tundish to drain |
| SV Safety Valve | |
| AAV Automatic air vent | |

Notice :

- This hydraulic schematic just shows the basic principle. The installation must be in accordance with local regulations.
- With underfloor heating an over temperature thermostat has to be installed.
- Anti thermal siphon dip has to be installed.
- up to five boilers can be linked together to provide sequence control



All UltraGas® boilers are commissioned by our dedicated service team.

For annual servicing of UltraGas® boilers and other equipment please contact our Hoval service department

e-mail: service@hoval.co.uk
 direct dial: 01636 593413 or 593435

Additional technical and installation information

Additional technical and installation information is available to download from our website www.hoval.co.uk (please go to the Operating and Maintenance Instructions download page). Information is available on water quality requirements, assembly, operation and servicing.

An expert partner



One-stop shopping

With us you can easily incorporate gas, oil, heat pump, solar, CHP, or biomass energy solutions into your heating system.



Technical advice

We are happy to assist you and your planning partners in developing intelligent systems, allowing you to take advantage of our expertise and the experience of our specialists.



After sales

For specialist commissioning and maintenance of your Hoval equipment, contact our service and spares department.

Hoval Ltd
Northgate
Newark-on-Trent
Nottinghamshire
NG24 1JN
United Kingdom

Phone 01636 672 711
Fax 01636 673 532
email boilersales@hoval.co.uk
www.hoval.co.uk

4212948/01 - 05/14

Responsibility for energy and environment

Hoval follows a policy of continued improvement and reserves the right to change specifications without notice.

Hoval