

Installation, Operation and Maintenance Instructions.

STU wood-pellet fired hot water boiler
(150-1000kW).

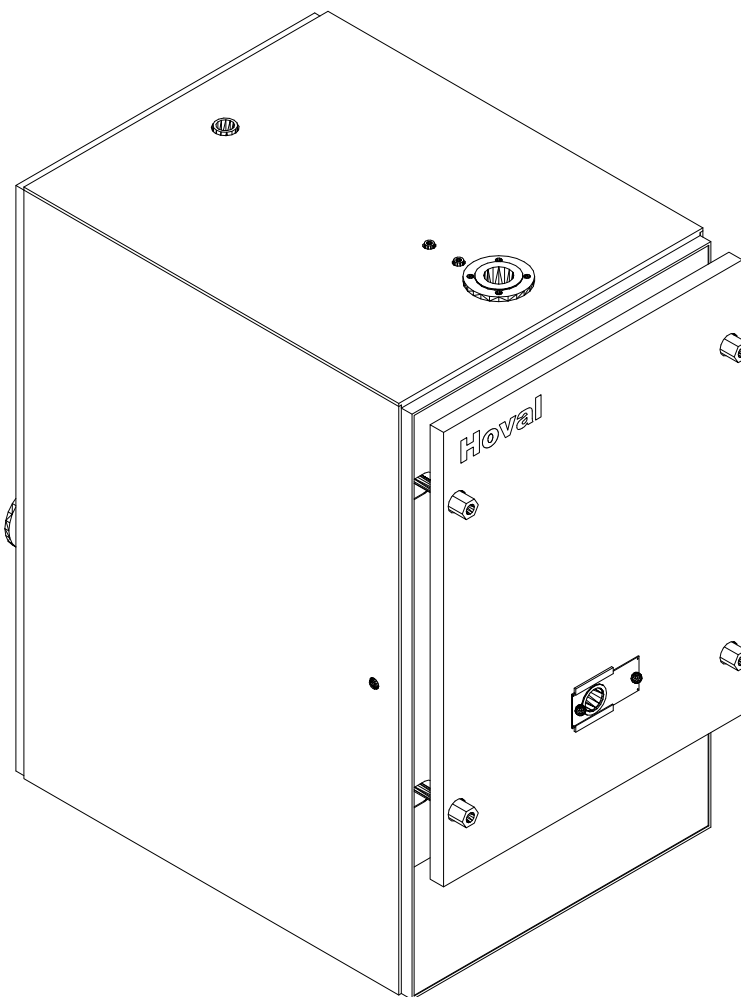

Hoval

STUman June 2010 (WA)



Contents

Introduction	3
Installation & Use	4
- Sample Nameplate	4
- Fuel Quality Requirements	4
Boiler Delivery, Offloading, Storage.	5
Description, Technical Performance and Dimensions of the STU Boiler	5-11
CF Filter - Description, Technical Performance, Typical Units & layout	12-16
Design Guidelines / Entry to fuel Store	17-18
Typical Plantroom Layouts	19-21
Boiler Door Handing	22
Boilerhouse Ventilation, Open Vented/Pressurised Systems	23
Requirements for pressure limiter(s) in accordance with BSEN 12828	23
Flues and Chimneys	24
Filling The System With Water	25
Water Flow and Return Temperatures	25
Control Details and Safety Features	26-31
Commissioning	32-33
Operating Instructions	34-36
Maintenance - Inspection & Servicing	37-38
- Periodic Inspection	37
- Boiler & Stoker Servicing	37
- Boiler Heating Surfaces	37
- Pick-Up Auger (Bunker Worm)	38
Appendix A - GRP Silo Specification Sheet	39
Appendix B - Thermal Safety Heat Exchange Details	40
Appendix C - Boiler familiarisation information	41-49
Appendix D - Operating, cleaning and fault - finding procedures	50-53
Notes	54-55

IMPORTANT

These instructions should be read and understood before attempting to install, commission or operate this unit.

Material in this publication may not be reproduced without the company's written permission.

Hoval Limited, Northgate, Newark, Notts NG24 1JN Tel: 01636 593413 or 593435 Fax: 01636 673532
 e-mail: service@hoval.co.uk or spares@hoval.co.uk Website: www.hoval.co.uk

Hoval reserve the right to change specifications without notice.

Introduction

These instructions have been written to give a brief description of STU wood pellet boilers, their installation, commissioning, operation and subsequent maintenance.

Important!

The STU boiler, stoker, fuel handling equipment and fuel store are designed to be used ONLY with good quality Wood Pellet Fuel in accordance with specifications as set out in Wood Fuel Specification CEN TC 335/CEN TS 14961, wood pellet fuel (see following page).

The installation of boilers and their ancillary equipment is normally carried out by the Heating Engineer, and for the purpose of this manual he is regarded as the installer and as such, it is his responsibility to ensure that he has read and understood the contents of this manual before installing the boiler.

It is essential that each boiler has all services connected to it before commissioning.

The installation should be in accordance with current I.E.E. Regulations, relevant British & European Standards and Codes of Practice, Building Regulations and Local Authority Bylaws.

Hoval, or Hoval Approved Engineers would normally commission the boiler. **Thereafter Hoval recommended that any Biomass Combustion equipment should only be placed into operation and maintained by suitably trained and authorised personnel.** We would encourage that the Heating Engineer and / or the client or the client's plant operators to be present at the time of commissioning as he / they can then be instructed on the day-to-day use and operation of the boiler. If this is not possible, or additional training is required, this can be arranged through Hoval.

The boiler combustion figures are recorded at the time of commissioning, added to a report and a copy of this will be issued for retention with this manual. We recommend that any information issued with the STU boiler should be kept ready and available to the operators of the equipment.

A note should be entered below by the person responsible for the plant, giving the boiler model, output and serial number ('K' number). This information is shown on the boiler data plate.

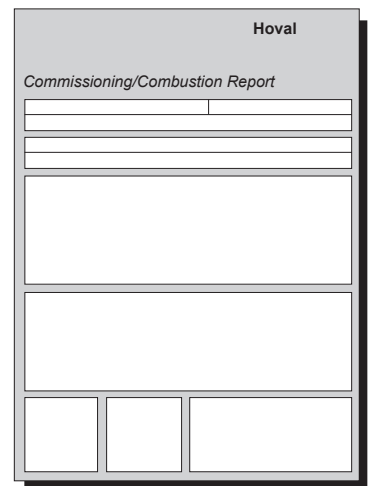

The image shows a thumbnail of a 'Hoval Commissioning/Combustion Report' form. The form has a header with the 'Hoval' logo and the title 'Commissioning/Combustion Report'. Below the title, there are several horizontal lines for text entry, followed by a large rectangular box for notes or observations, and a table with three columns at the bottom.

<i>For completion by Plantroom Attendant</i>	
Boiler Model: _____	
Output (kW): _____	Fuel Supplier: _____
K No.: _____	Commissioning Date: _____

***For technical, servicing or parts enquiries,
telephone, fax or e-mail Hoval
quoting the boiler(s) serial number, as above
Tel: (01636) 593413 or 593435 Fax: (01636) 673532
e-mail: service@hoval.co.uk or spares@hoval.co.uk***

Installation and Use.

The installation of the boiler and stoker must be in accordance with the relevant British Standards, I.E.E. Regulations and the by laws of both the Local Authority and the local Water Authorities.

A flat level fire proof floor should be provided - the location should permit the provision of a satisfactory flue system and adequate air supply.

The STU Wood Pellet Boiler is designed and approved for use as a heat generator for hot water heating systems with flow temperatures up to 85°C and a maximum working pressure of 3 bar. The boilers have been tested and certified by TÜV and they comply with the requirements of the European standard for boilers for solid fuels BS EN 303-5 (Note: BS EN 303-5 is limited to boilers with outputs of 300kW or less, however for outputs exceeding 300kW the boilers are tested using the procedures as set out in BS EN 303-5 and fully meet the required standard). The STU boiler has an automated pellet delivery system and is not designed for "hand" or manual feeding of wood pellets under any circumstances.

Sample nameplate

A nameplate will be attached to one of the side casing panels of the boiler. This plate includes the serial number identifying the boiler.

Hoval Limited, Northgate Newark. Notts NG24 1JN Tel: 01636 672711 Fax: 01636 673532		
Boiler Model :	STU WOOD PELLETT	
Type :	STU 200	
Serial No :	K	
Year of Manufacture :	2010	
Output (wood pellets) :	200 kW	
Input (wood pellets) :	253 kW	
Maximum Heat Output :	200 kW	
Flue Temp (wood pellets) :	180°C	
Operating Temperature :	Min 60 Deg C Max 90 Deg C	
Working Pressure :	3.00 bar	
Test Pressure :	5.55 bar	
Water Content :	824 Litres	
Electrical Connection :	3ph / 50Hz / 400V	
<small>This appliance must be installed in accordance with the rules in force and used only in a sufficiently ventilated space. Consult instructions before installation and use of this appliance.</small>		

Fuel Quality Requirement

The design of the boiler, stoker, pellet handling system and store is dependant on using the correct quality wood pellet fuel.

The pellets should be formed from clean or virgin timber where they are held together with the natural resin and binders (or lignin) in the wood fuel. The fuel MUST NOT contain halogenated organic compounds or heavy metals as a result of treatment with wood preservatives or coating.

Specifications of wood biomass fuels can be found at BS EN303-5 Table 8 Test fuels. Compressed wood (C) and / or CEN/TS14961, Solid biofuels Fuel specifications and classes.

Hoval suggests that the following fuel specification (As Recieved) for use on the STU wood pellet boiler,

Calorific Value net basis CV:	Minimum 17,000 kJ/kg (4.72 kWh/kg).
Moisture Content M10:	Moisture Content is no more than 10%.
Ash Content A1.0	Ash Content is no more than 1%.
Size D06 :	Pellet Diameter either 6mm preferred (8mm may be acceptable).
Pellet Length:	Typical pellet length 20-30mm.
Fines Content F1.0:	As Loaded into Delivery Vehicle Fines (-3mm material) no more then 1%.
Sulphur S0.05:	Sulphur Content no more than 0.05%.
Mechanical Durability DU97.5:	

Fuel Delivery

Wood Pellet fuel to be delivered by specialist vehicle as utilised by the appointed fuel supplier to site. Fuel delivery via bulk blower vehicles fitted with suitable low-pressure blowers. Hoval do not recommend or endorse any particular fuel supplier or manufacturer however it is recommended that fuel is ALWAYS supplied against a specification and the supplier concerned operates well maintained vehicles and fully trained delivery drivers to ensure that the boiler and fuel transfer system are presented with well sized wood pellets that are free from any contamination.

Boiler Delivery, Offloading and Storage

Boilers and associated equipment are normally delivered by our own transport on a mutually agreed date. The boiler can be off-loaded by the crane lorry if specifically booked at the time of ordering. Adequate lifting points are provided on the boiler shell.

The STU Wood Pellet Boiler would normally be delivered fully cased with the boiler temperature gauge attached. The stoker, the fuel delivery system and the associated control panel would normally be delivered and supplied with the boiler. The stoker control panel can either be mounted on the side of the boiler (standard) or supplied separately for mounting on a wall within the boiler house.

Where specified any pellet store may be supplied separate to that of the boiler.

On delivery the installer should check all items against the delivery note and should then store them in a safe secure dry place.

(There may be small items such as cleaning tools and safety valves, which are transported in the boiler combustion chamber. These should be removed and also stored in a safe place).

Note: Hoval approved engineers will assemble the stoker and the fuel feed system but would normally expect the installer to wire between the various motors and dampers on the stoker and the control panel unless it is mounted on the boiler or unless the wiring instruction is given at the time of order. Detailed instruction as to how to complete this wiring is available separately.

Description and Technical Performance of the STU Wood Pellet Boiler

Applications

These boilers are intended for heating commercial and industrial premises within the limits of temperature and pressure stated within this manual. They may also be used to supply DHW to such premises in conjunction with an indirect calorifier.

General Details

Based on Hoval's well-established ST design the STU Wood Pellet boiler is a welded steel boiler complete with a matched pellet stoker, designed to operate with wood pellet fuel. As standard the stoker is supplied for manual lighting of the fuel bed. An optional ignition start system is available on request, but this must be specified at the time of order.

The boiler comprises of a welded steel shell with a water jacket surrounding an oval combustion chamber and a single bank of smoke tubes.

STU Wood Pellet boilers are offered in outputs from 150 to 1000kW for heating only, the standard version available for operating working pressures of up to 3 bar and temperatures of 85°C.

Manufactured in the UK under ISO 9001:2000 Quality Management System.

The STU has been designed with generous water content and good natural circulation is achieved through the boiler with wide unrestricted waterways and optimum location of the flow and return connections.

Boiler flow connection is located off the top of the boiler. Two return connections are located either side at the rear of the boiler. Return water flow should be divided equally across both returns to promote good water circulation.

A safety valve needs to be fitted on the boiler.

Boiler Door Hinging can be either side (standard is right hand side).

Insulated with high-density mineral fibre mats with woven fabric surface reinforced as boiler cladding insulation.

Meets BS EN303-5 Class 3 requirements with respect to Safety, Boiler Efficiency and Emissions.

Each STU boiler is fitted with thermostatically controlled Thermal Safety overheat coils.

Boiler Control includes flow temperature control along with limit stats. In addition each STU is supplied with a Control Panel incorporating the following switches: ON/OFF isolator, AUTO/IGNITION (where optional ignition start system is specified), BURNOUT/NORMAL and Wood Burner ID FAN ONLY/OFF/AUTO that controls the stoker along with a LRP controller and display. Normal operation is fully automatic in conjunction with a simple time switch or some other form of control, i.e. BMS enable signal. On STU models 500 to 1000, inverter drive units are supplied as standard for control of the conveyor auger, FD fan and ID fan motors. On request these are available as an option on models 150 to 425, which must also be specified at the time of order.

Electrical power supply; A three phase 400V, 32A isolated supply is to be provided by the installer to the Stoker Control Panel. Specific wiring diagrams will be issued on commissioning.

Stoker Detail

Each boiler is supplied with a fully integrated pellet-burning stoker comprising combustion retort(s), modulating delivery auger(s), a transfer box, fully modulating primary (FD), secondary (ID) fans and lambda control. The transfer box is integrated with a bulk pellet store via either angled pick-up auger(s) or a flexible centreless auger arrangement depending on site layout. The stoker can be arranged to deliver the fuel into the rear (standard supply) or the front of the boiler depending on site layout, the pick-up arrangement being designed to suit site requirements.

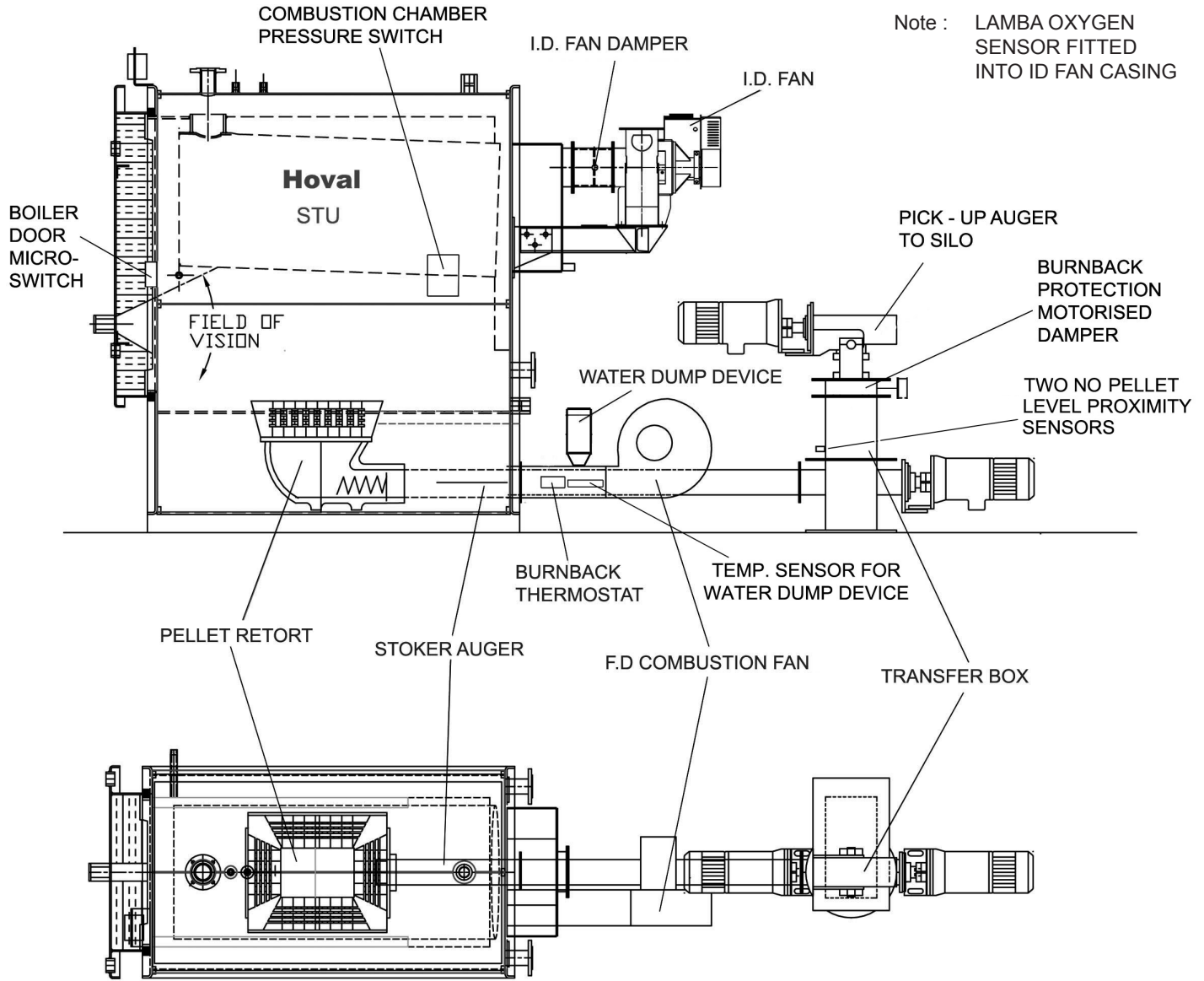

The stoker connects the boiler and the bulk pellet store via the Transfer Box. Wood pellet is collected at the outlet of the store and moved to the Transfer Box via a Pick-Up Auger (or a Centreless Flexible Auger - see typical layout drawings), and then delivered into the retort within the boiler via a Delivery Auger.

The stoker automatically adjusts the fuel feed to match the boiler load. Continuous O₂ monitoring of flue gases ensures close combustion control as the air supply is adjusted to match the fuel feed.

The standard stoker design incorporates an airless kindle feature. This allows the boiler under normal operation, to be held in "stand-by" mode when heat is not required for up to 72 hours and maintains a small ignition source within the stoker retort to allow quick response to a sudden call for heat outside normal operation. An electric ignition system is available as an option. If it is anticipated that the available heating load would lead to any boiler kindling in excess of this period, then it should be switched off .

Each Stoker Control Panel displays the boiler-operating condition and set points along with boiler operating temperature, flue gas temperature (optional) and O₂ readings. Individual readings can be displayed or combined and shown as a trend.

Each Delivery Auger is fitted with two separate safety features to detect and correct any pellet burn back; an overheat burnback thermostat linked to the stoker control and a water dosing device independent of electric supply. Pellet level in the transfer box is controlled via two proximity sensors to give an additional firebreak. A motorised burnback protection damper is also fitted between the transfer box and the pick-up auger which will close in the event of the burnback thermostat been initiated. It will also close in the event of a power failure.

Technical Data

STU Wood-Pellet Boiler

Type		150	200	250	300	350	425	500	600	800	1000
• Output Maximum	kW	170	220	270	325	376	450	501	650	800	1200
• Output Minimum	kW	51	85	95	115	117	150	150	250	320	350
Nominal Output	kW	156	200	250	300	376	425	501	600	800	1085
• Full Load (nominal Output) Efficiency nCV %		88.4	89.0	89.6	90.1	90.7	90.7	90.7	91.6	92.6	93.5
• Part Load Efficiency nCV	%	85.2	86.5	87.8	89.1	90.4	90.5	90.6	91.0	91.3	91.7
• Flue Gas Temperature Nominal Output	°C	146	152	159	165	171	170	168	159	150	140
• Flue Gas Temperature Min. Output	°C	97	98	99	99	100	90	80	80	80	80
• Full Load Carbon Dioxide	%	11.7	12.4	12.8	13.2	13.2	13.2	13.3	13.8	14.4	14.9
• Flue Gas Mass Flow ⁽¹⁾	kg/h	380	500	620	740	890	1050	1250	1490	1980	2470
Pellets⁽²⁾											
• Diameter	mm	6 - 8	6 - 8	6 - 8	6 - 8	6 - 8	6 - 8	6 - 8	6 - 8	6 - 8	6 - 8
• Length	mm	20 - 30	20 - 30	20 - 30	20 - 30	20 - 30	20 - 30	20 - 30	20 - 30	20 - 30	20 - 30
• Consumption at nominal Output	kg/h	37	47	58	69	86	98	115	136	180	242
• Maximum Operating Temperature	°C	85	85	85	85	85	85	85	85	85	85
• Minimum Boiler Return Temperature	°C	60	60	60	60	60	60	60	60	60	60
• Operating Pressure	bar	3	3	3	3	3	3	3	3	3	3
• Test Pressure	bar	4.5	4.5	4.5	4.5	4.5	4.5	4.5	4.5	4.5	4.5
• Hydraulic Resistance at 82/71°C	kPa	0.56	0.93	1.45	2.09	2.07	2.65	3.68	5.28	5.87	6.11
• Water Flow Rate 82/71°C	kg/s	3.4	4.3	5.4	6.5	8.2	9.2	10.9	13.0	17.4	21.7
• Hydraulic Resistance at 80/60°C	kPa	0.2	0.3	0.4	0.6	0.6	0.8	1.1	1.6	1.8	1.9
• Water Flow Rate 80/60°C	kg/s	1.9	2.4	3.0	3.6	4.5	5.1	6.0	7.2	9.6	11.9
• Boiler water content	litres	605	824	795	795	1110	1070	1473	1458	2592	2731
• Flue Connection ID ⁽³⁾	mm	200	200	250	250	250 - 300	300	300	350	350 - 400	350 - 400
• Min Bouyancy Required at outlet (under pressure or draught)	Pa	10 - 30	10 - 30	10 - 30	10 - 30	10 - 30	10 - 30	10 - 30	10 - 30	10 - 30	10 - 30
• Electrical Supply ⁽⁴⁾	ph/v/Hz	3/400/50	3/400/50	3/400/50	3/400/50	3/400/50	3/400/50	3/400/50	3/400/50	3/400/50	3/400/50
• Dry Weight (approx)	kg	1860	3050	3150	3150	3231	3480	3966	4060	6994	7384
Indicitive Emissions at Full Load											
• CO Corrected 10% O ₂	mg/m ³	354	275	195	116	36	69	102	72	43	13
• Particulate Corrected 10% O ₂	mg/m ³	81	67	52	38	23	87	150	105	25	15
• NO _x	mg/MJ	64	68	72	76	80	78	75	82	90	97

(1) Under Typical Combustion Conditions Full Load.

(2) Assumed Moisture Content 10%, CV 4.83 nkWh/Kg.

(3) Suggested Flue Diameter - ID fan has Rectangular section - actual can depend on flue route. Figures indicated deliver efflux velocities 5 - 7 m/s at full load.

(4) 32 Amp 400V 3 Phase Supply to Stoker Control Panel.

Note: An adequate Pump overrun period is required to dissipate heat within a STU boiler following each operating period. This should be determined at the time of commissioning.

Dimensions and Technical Information

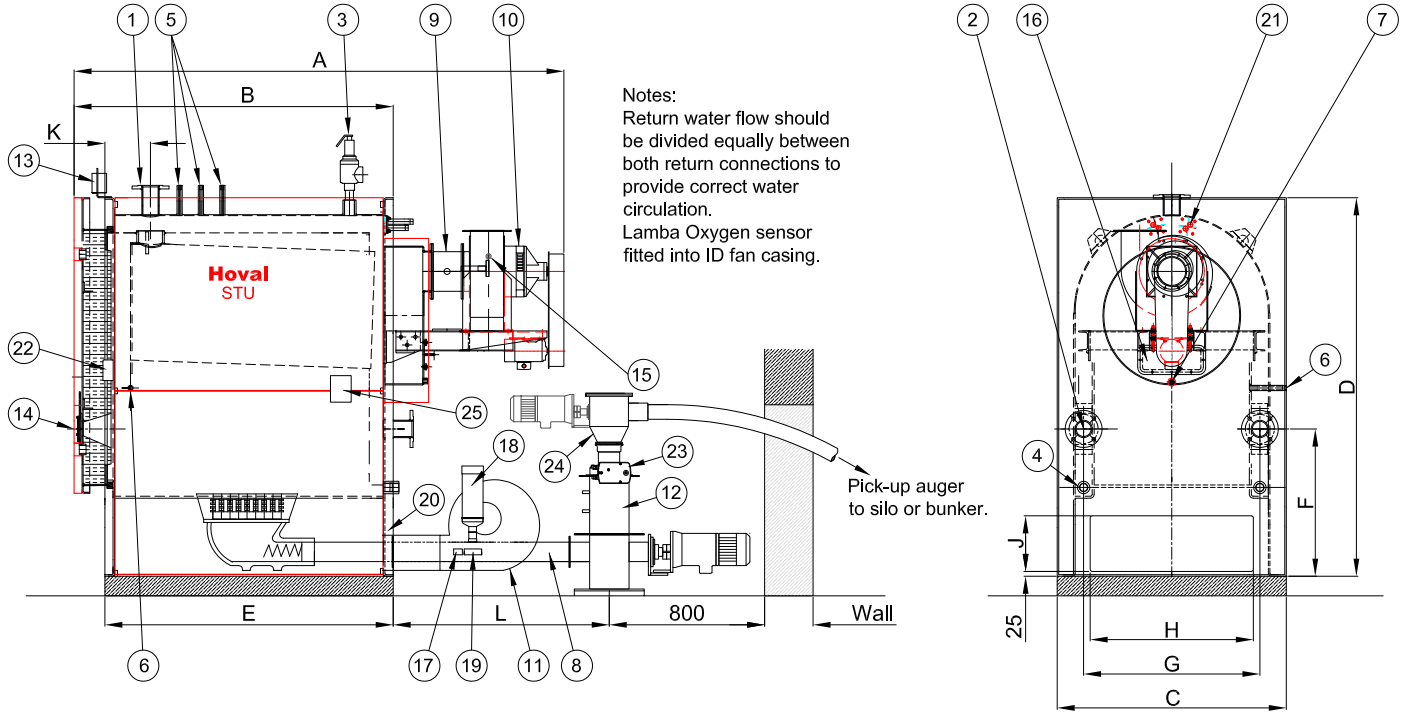

STU Boiler		150	200	250	300	350	425	500	600
Dimensions:									
A	(mm)	2441	2428	2523	2523	3038	3078	3078	3539
B	(mm)	1657	1644	1644	1644	2159	2159	2159	2619
C	(mm)	900	1180	1180	1180	1180	1180	1180	1180
D	(mm)	1740	1940	1940	1940	1940	1940	1940	2210
E	(mm)	1499	1485	1485	1485	2000	2000	2000	2460
F	(mm)	572	755	755	755	755	755	755	730
G	(mm)	680	908	908	908	908	908	908	855
H	(mm)	640	840	840	840	840	840	840	840
J	(mm)	285	285	285	285	285	285	285	285
K	(mm)	240	235	235	235	235	235	235	275
L	(mm)	1008	1116	1116	1116	1516	1516	1516	1516

Connections:									
1	Flow	(PN6)	DN50	DN80	DN80	DN80	DN80	DN80	DN100
2	Return	(PN6)	2xDN50	2xDN80	2xDN80	2xDN80	2xDN80	2xDN80	2xDN100
3	Safety valve	(BSP)	G1.1/2"	G2"	G2"	G2"	G2"	G2"	G2"
4	Drain	(BSP)	2xG1.1/2	2xG1.1/2	2xG1.1/2	2xG1.1/2	2xG1.1/2	2xG1.1/2	2xG1.1/2
5	Stat pockets	(BSP)	G1/2"	G1/2"	G1/2"	G1/2"	G1/2"	G1/2"	G1/2"
6	Pressure switch	(BSP)	R3/4"	R3/4"	R3/4"	R3/4"	R3/4"	R3/4"	R3/4"
7	Smoke box drain	(mm)	G3/4"	G3/4"	G3/4"	G3/4"	G3/4"	G3/4"	G3/4"
8	Delivery auger	(mm)	100	100	100	100	125	125	125
9	Damper assembly	(mm)	150	150	200	200	200	255	255
10	ID inlet fan	(mm)	150	150	200	200	200	255	255
Halifax fan No			9	9	12	12	12	15	15
ID fan outlet		(mm)	146x127	146x127	172x191	172x191	172x191	216x241	216x241

Key:

- 1 Flow
- 2 Returns - One either side, both to be connected to a common inlet header
- 3 Safety valve connection
- 4 Drain connections (plugged)
- 5 Stat & modulating sensor mounting sockets
- 6 Combustion chamber pressure switch connection
- 7 Smoke box condensate drain
- 8 Delivery auger
- 9 Damper assembly
- 10 ID fan
- 11 FD fan
- 12 Transfer box with two proximity sensors.
- 13 Temperature gauge
- 14 Sight glass assembly
- 15 Lambda oxygen sensor
- 16 Smokebox cleaning door
- 17 Burn back thermostat
- 18 Burn back water dump device
- 19 Temp sensor for water dump device
- 20 Optional Electric ignition gun behind removable panel
- 21 Thermal Safety Overload
- 22 Boiler door microswitch
- 23 Motorised Burnback Protection Damper
- 24 EB outlet box
- 25 Combustion Chamber pressure switch

An automatic air vent, should be fitted by the installer at high level on the flow pipework connecting to the boiler.



A 3ph + N 32A 400V supply is required for the control panel operation.

Notes:

- Thermal safety heat exchanger connections c/w thermostatic control valve connection (3/4") to be connected to a cold water mains supply. Drain pipework (by others) to be run via tundish to drain. See Appendix B for further details.
- Boiler mounted control panel not shown but typical sizes are:
 Models 150 to 425: 600mm W x 800mm H x 260mm D
 Models 500 and 600: 800mm W x 1200mm H x 300mm D
 This may change and should be checked on a site by site basis.

Dimensions and Technical Information

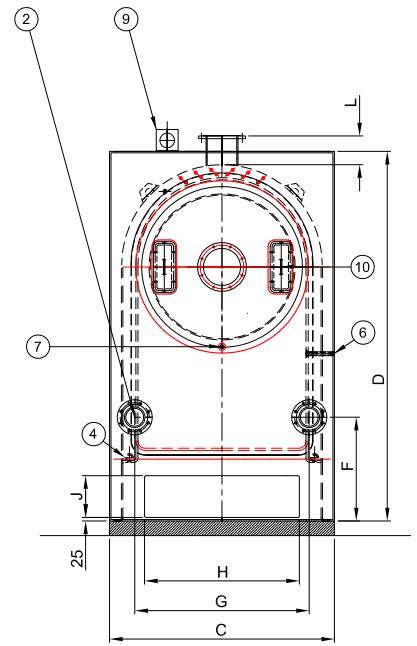
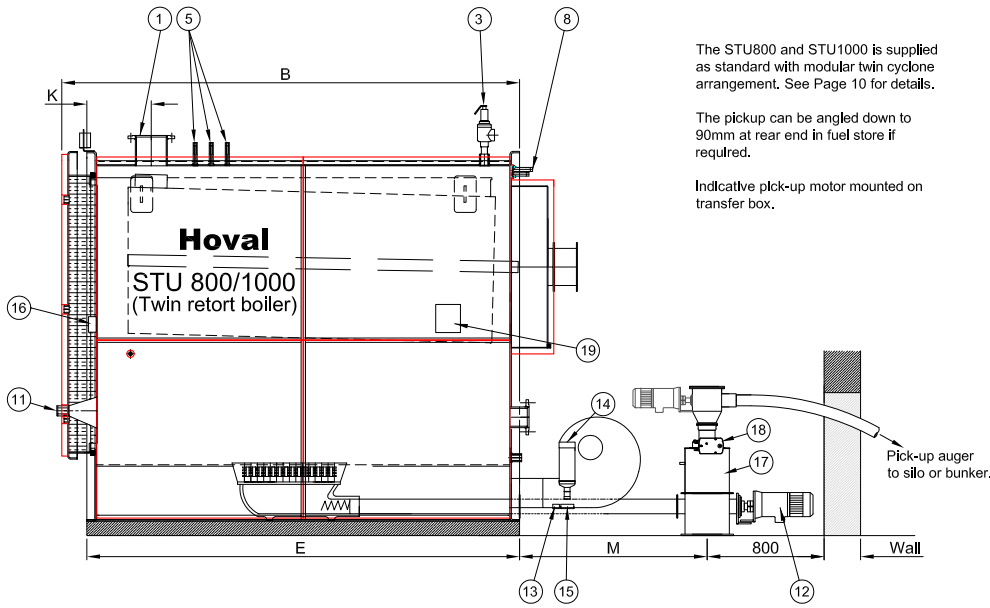

STU Boiler		800	1000	Connections:	800	1000
A	(mm)	-	-	1 Flow	(PN6) DN125	DN150
B	(mm)	3134	3282	2 Return	(PN6) 2xDN125	2xDN150
C	(mm)	1540	1540	3 Safety valve	(BSP) G2"	G2"
D	(mm)	2530	2713	4 Drain	(BSP) 2xG1.1/2	2xG1.1/2
E	(mm)	2962	3110	5 Stat pockets	(BSP) 2xG1/2"	2xG1/2"
F	(mm)	710	723	6 Pressure switch	(BSP) R3/4"	R3/4"
G	(mm)	1195	1150	7 Smoke box drain	(mm) G3/4"	G3/4"
H	(mm)	1060	1060	8 Cooling Coils	(mm) G3/4"	G3/4"
J	(mm)	285	285			
K	(mm)	441	441			
L	(mm)	200	200			
M	(mm)	1284	1299			

- Notes:**
- Thermal safety heat exchanger connections c/w thermostatic control valve connection (3/4") to be connected to a cold water mains supply. Drain pipework (by others) to be run via tundish to drain. See Appendix B, for further details.
 - Boiler mounted control panel not shown but the typical size for models 800 and 1000: 800mm W x 1200mm H x 300mm D
This may change and should be checked on a site by site basis.

Key:

- 1 Flow
- 2 Returns, one either side, both to be connected to a common inlet header
- 3 Safety valve connection
- 4 Drain connections (plugged)
- 5 Stat & modulating sensor mounting sockets
- 6 Combustion chamber pressure switch connection
- 7 Smoke box condensate drain
- 8 Cooling coils c/w temp sensor
- 9 Temperature gauge
- 10 Smoke box cleaning doors
- 11 Sight glass assembly
- 12 Twin delivery augers
- 13 Burn back Stat (one per stoker)
- 14 Burn back water dump (one per stoker)
- 15 Temp. sensor for water dump device (one per stoker)
- 16 Boiler door Microswitch
- 17 Common transfer box with two No. proximity sensors
- 18 Motorised burnback protection damper
- 19 Combustion Chamber Pressure switch

An automatic air vent, should be fitted by the installer at high level on the flow pipework connecting to the boiler.

A 3ph + N 32A 400V supply is required for the control panel operation.

Dimensions and Technical Information

Modular Twin Cyclone

Modular Twin Cyclone unit supplied with the STU800 and the STU1000 boilers, along with floor mounted Induced Draught fan (not shown)

The unit and ID fan are to be mounted adjacent to (alongside or at rear) of the boiler to suit specific plant room layout. See Page 11 for a typical plant room layout

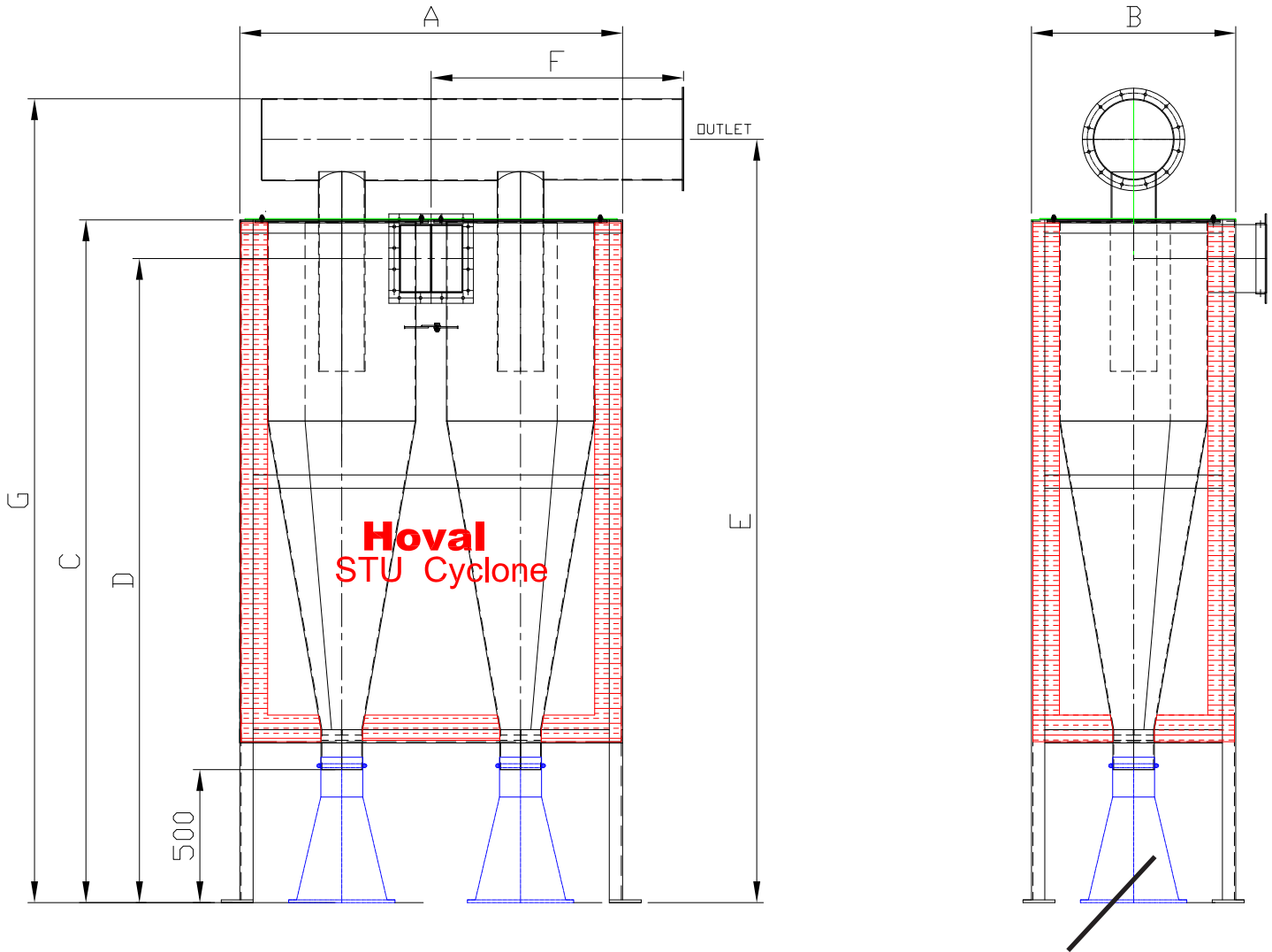

Particulate Matter collection bag

Cyclone		800	1000
A	(mm)	1389	1439
B	(mm)	744	768
C	(mm)	2368	1540
D	(mm)	2227	2422
E	(mm)	2615	2872
F	(mm)	900	950
G	(mm)	2742	3024
Inlet Duct	(mm)	228x248	238x256
Outlet Duct	(mm)	254 I/D	305 I/D

Notes: The particulate matter collected in the cyclone bags contains heavy metals and must be correctly disposed. Not required if these boilers are fitted with an optional CF Biomass Filter unit.

Dimensions and Technical Information

Typical Layout

Hoval STU Boiler with modular twin cyclone, floor mounted ID fan and connecting ductwork.

Hatched ducting **NOT** by Hoval

To suit specific plant room layouts. Note easy radius bends in ducts.

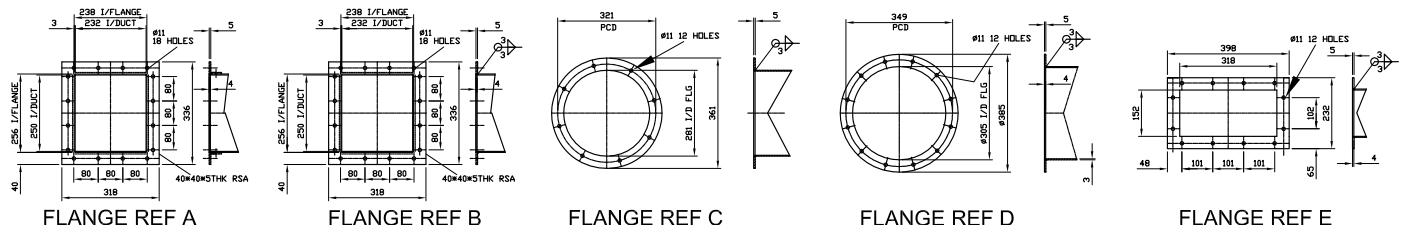
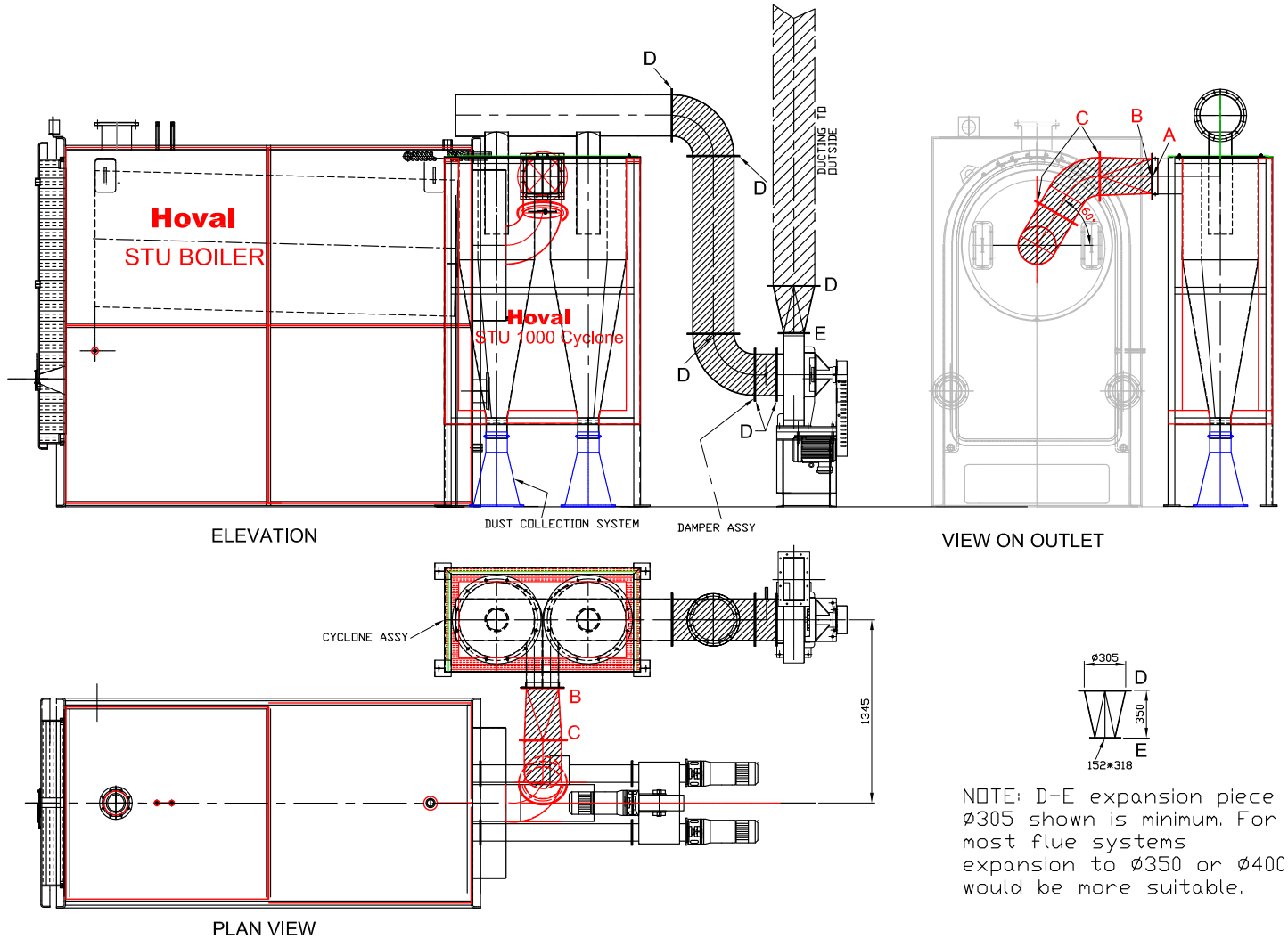

Hoval CF Biomass Filter. Advanced air filtration for biomass heating.



Hoval CF 70 Biomass Filter

The Hoval CF Biomass Filter is an optional bespoke engineered air filtration device designed to remove air borne particles from the combustion gasses of biomass pellet heating boilers. The unit is skid mounted and includes an integral induced draught fan sized to fit the range of Hoval biomass pellet boilers¹. The unit is suitable for both new and retrofit installations where footprint allows. The control, efficiency and safety philosophy of the biomass boiler combustion is integrated seamlessly into the CF Biomass Filter. The unit is available in various sizes and dimensions suitable for boiler outputs from 50kW to 1200kW. The units can also be fitted to other biomass pellet boilers. For guidance and details please contact Hoval's Technical Department.

The Hoval CF Biomass Filter is a compact unit comprising vertically arranged ceramic filter elements cased in metal sheeting encompassing its own electronic controls and compressed air fed self-cleaning technology. The base of the unit comprises a bin for collection and removal of cleaned air borne particulate. The greater the output of the boiler the greater the number of filter elements required to clean the particulates from the flue gas.

The unit is always situated downstream from the point of biomass combustion and cleans the flue gasses effectively regardless of load or degradation of fuel quality. The filtration process effectively removes up to 96% of air borne PM2.5 and PM10 combustion particulates.

The combustion gasses pass through the ceramic filter elements and are cleaned during this process. Particulates and dust are collected on the surface of the ceramic filter that is then cleaned, at pre-set timed intervals, by a controlled blast of compressed air¹ that dislodges the collected particles causing them to fall downwards and collect in the ash bin. The ash bin can then be safely emptied at controlled intervals.

The ceramic filter elements are designed to have an operational life of between 3-5 years depending on the level of filtration in use. The elements are easily replaced by vertically removing the existing elements from the unit and replacing with a new element. Accordingly it is essential to locate the filter with a minimum of one metre headroom above the unit.

The unit has been independently performance tested by TÜV under both perfect and imperfect combustion conditions with results that indicate post combustion particulate reduction to a level of less than 5mg/m³.

Areas of Use:

Due to the excellent particulate filtration properties of the unit it is ideally suited to be used in areas where ground level air particulate pollution is already high. The use of the CF Biomass Filter in urban areas will negate the impact of additional air borne particulate from biomass combustion used for space heating and generation of hot water.

- City centres and other high density urban population concentrations
- Locations with high levels of existing or planned road traffic
- Locations with high levels of existing or planned industrial activity

As a result of the filtration process where the CF Biomass Filter is fitted there is no need to increase stack height for the purpose of particulate dispersion. However, all factors relating to combustion need to be verified on a site by site basis.

The use of alternative abatement technology such as the larger cyclone technology (supplied as standard with many biomass boilers – including the larger Hoval STU pellet boilers) will reduce the air borne particulate pollution in the PM10 category, but will not generally remove significant quantities of the smaller PM2.5 particles. In rural areas where there is a low background level of air pollution and only a seasonal heating load the use of cyclone technology may be acceptable.

In all circumstances, however, the quality of fuel at point of combustion remains of paramount importance to the operational performance, efficiency of the boiler and the level of air borne particulates.

¹ Compressed air supply by others.



Ceramic filters in virgin state



Ceramic filters after cleaning process



Birds eye view of opened CF Biomass

Technical Information

Boiler	Filter	Maximum boiler output kW	Max particulate emission level ⁴	Dimensions (mm)			Weight (approx) kg	Maximum flue gas flow ¹ @ 200°C m ³ /hr	Maximum temperature °C	Compressed air consumption ² m ³ /hr
				Height	Length	Depth				
STU 150	CF 150	170	<5mg/m ³	1510	1295	1255	440	510	230	0.36
STU 200	CF 200	220	<5mg/m ³	1925	1700	1810	600	672	230	0.36
STU 250	CF 250	270	<5mg/m ³	1925	2010	1540	720	833	230	0.61
STU 300	CF 300	325	<5mg/m ³	1925	2010	1720	879	994	230	0.61
STU 350	CF 350	376	<5mg/m ³	1925	2010	1877	930	1195	230	0.61
STU 425	CF 425	450	<5mg/m ³	1925	2080	2060	1050	1410	230	0.61
STU 500	CF 500	501	<5mg/m ³	1925	2080	2260	1150	1679	230	0.61
STU 600	CF 600	650	<5mg/m ³	1925	2290	2510	1300	2001	230	0.61
STU 800	CF 800	800	<5mg/m ³	1925	2760	2165	1420	2659	230	0.98
STU 1000	Twin CF 1000	1200	<5mg/m ³	1925	3520	2915	2650	3317	230	1.22

Boiler	Filter	Induced Draught Fan			Incoming Electrical Supply
		Type	Motor kW	Absorbed power kW	
STU 150	CF 150	Halifax	1.5	0.89	3N ~50Hz 400/230V 10A (max)
STU 200	CF 200	Halifax	1.5	0.86	3N ~50Hz 400/230V 10A (max)
STU 250	CF 250	Halifax	2.2	1.06	3N ~50Hz 400/230V 10A (max)
STU 300	CF 300	Halifax	2.2	1.28	3N ~50Hz 400/230V 10A (max)
STU 350	CF 350	Halifax	2.2	1.64	3N ~50Hz 400/230V 10A (max)
STU 425	CF 425	Halifax	3.0	1.97	3N ~50Hz 400/230V 10A (max)
STU 500	CF 500	Halifax	3.0	2.20	3N ~50Hz 400/230V 10A (max)
STU 600	CF 600	Halifax	4.0	2.81	3N ~50Hz 400/230V 10A (max)
STU 800	CF 800	Halifax	5.5	3.40	3N ~50Hz 400/230V 10A (max)
STU 1000	Twin CF 1000	Halifax	5.5	4.00	3N ~50Hz 400/230V 10A (max)

- Notes:
- ¹ The maximum flue gas flow is based on typical combustion conditions at high fire.
 - ² A suitable compressed air supply is required for the automatic filter cleaning system (compressor available as an optional extra). The consumptions stated above are based on a 4 bar supply and one full clean down cycle of all filters per hour.
 - ³ The maximum moisture content of the pellets should be no greater than 10%.
 - ⁴ Equivalent to <2mg/MJ (2g/GJ).

Typical units

(Measurements in mm)

CF 500 unit

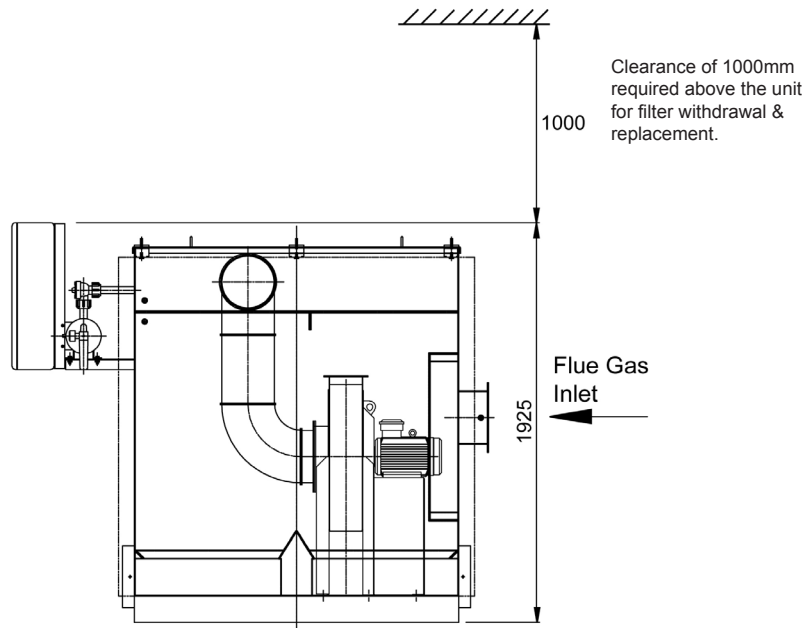
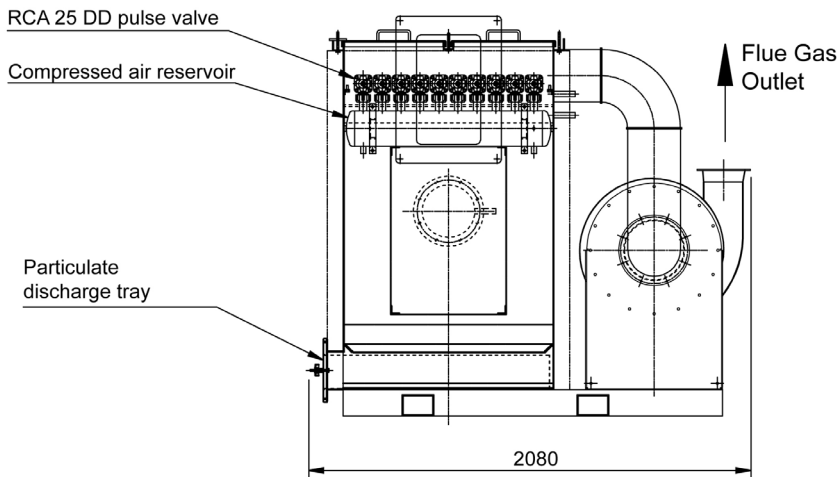
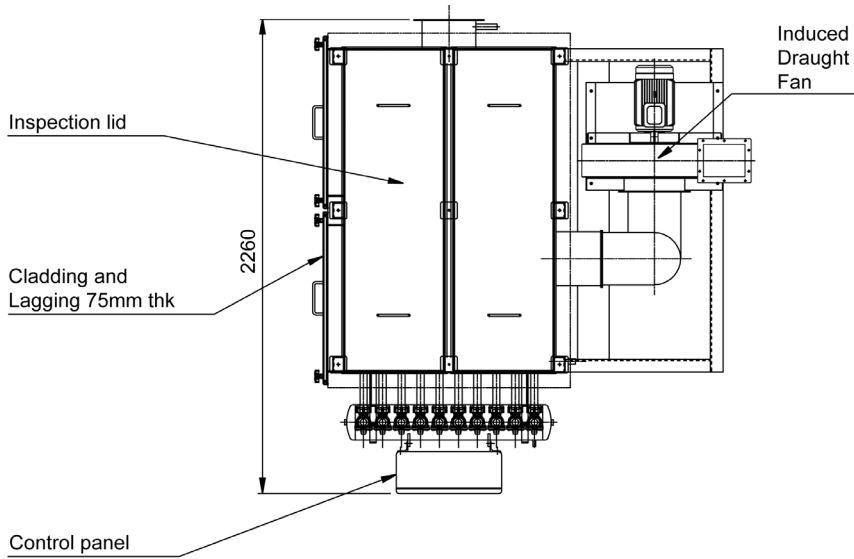

Typical units

(Measurements in mm)

Twin CF 1000 unit

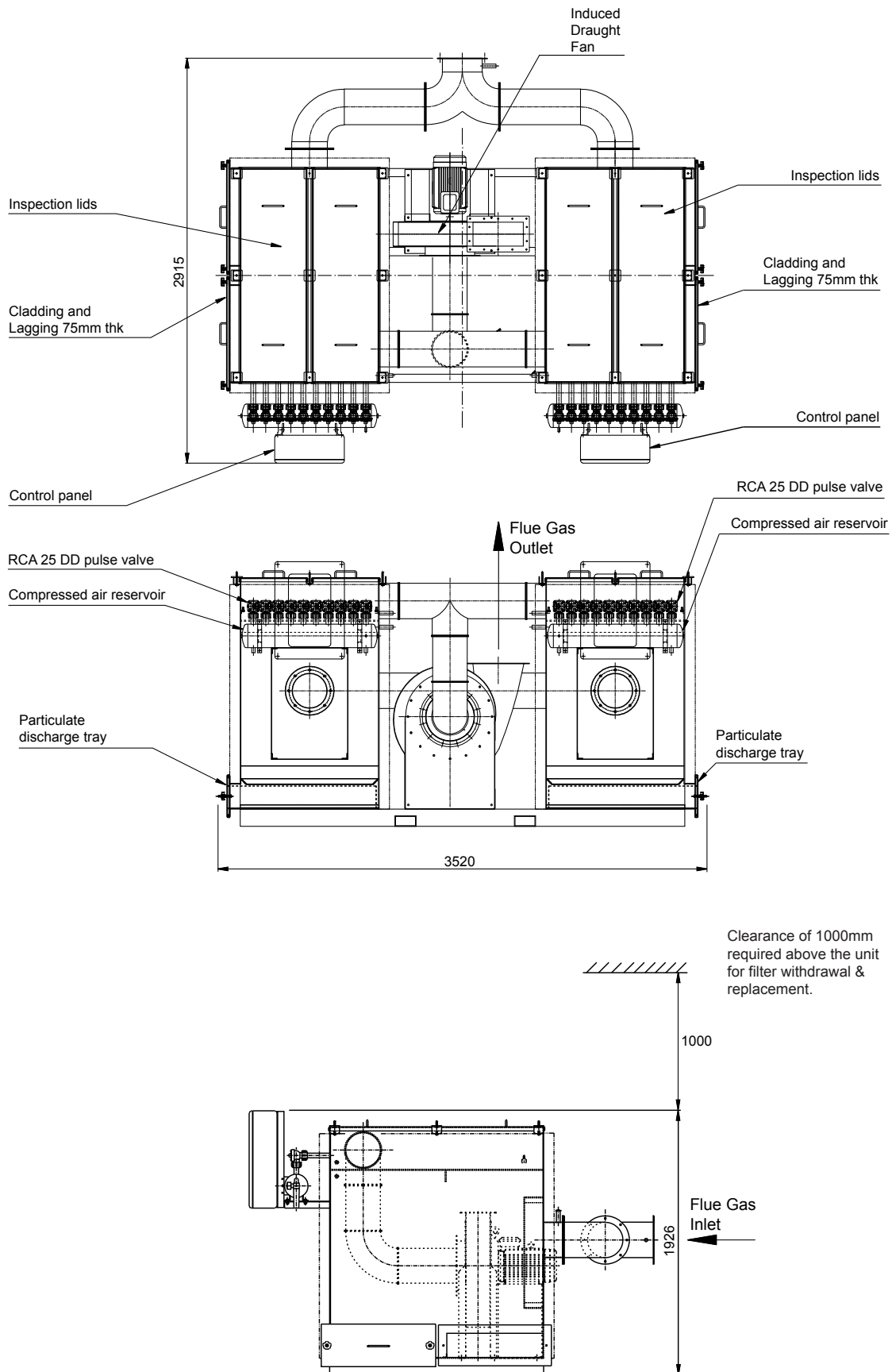

Typical Layout

STU 200 Wood Pellet Boiler with CF 200 Biomass Filter

Hatched ducting not by Hoval. Note easy radius bends should be used.

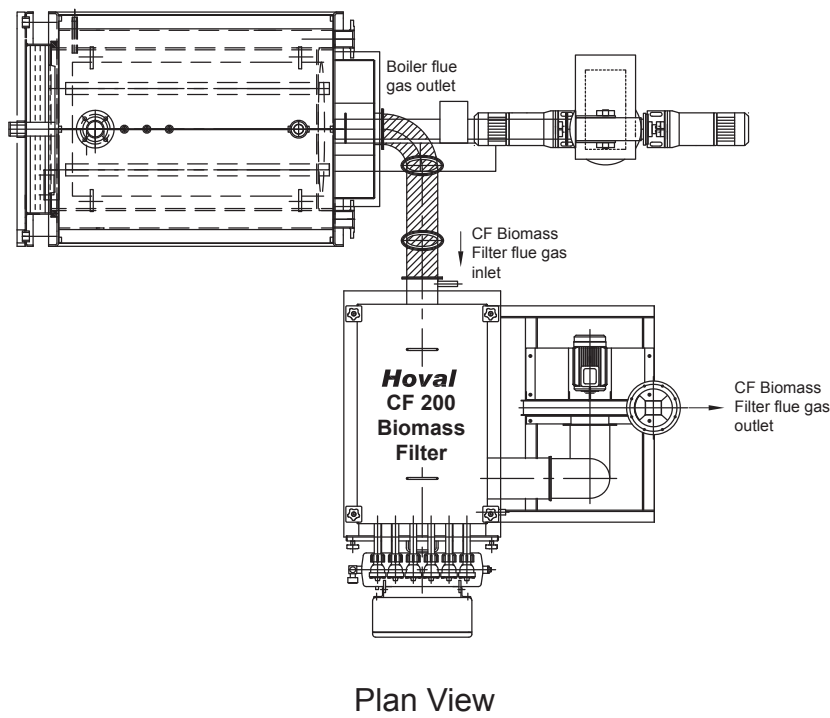
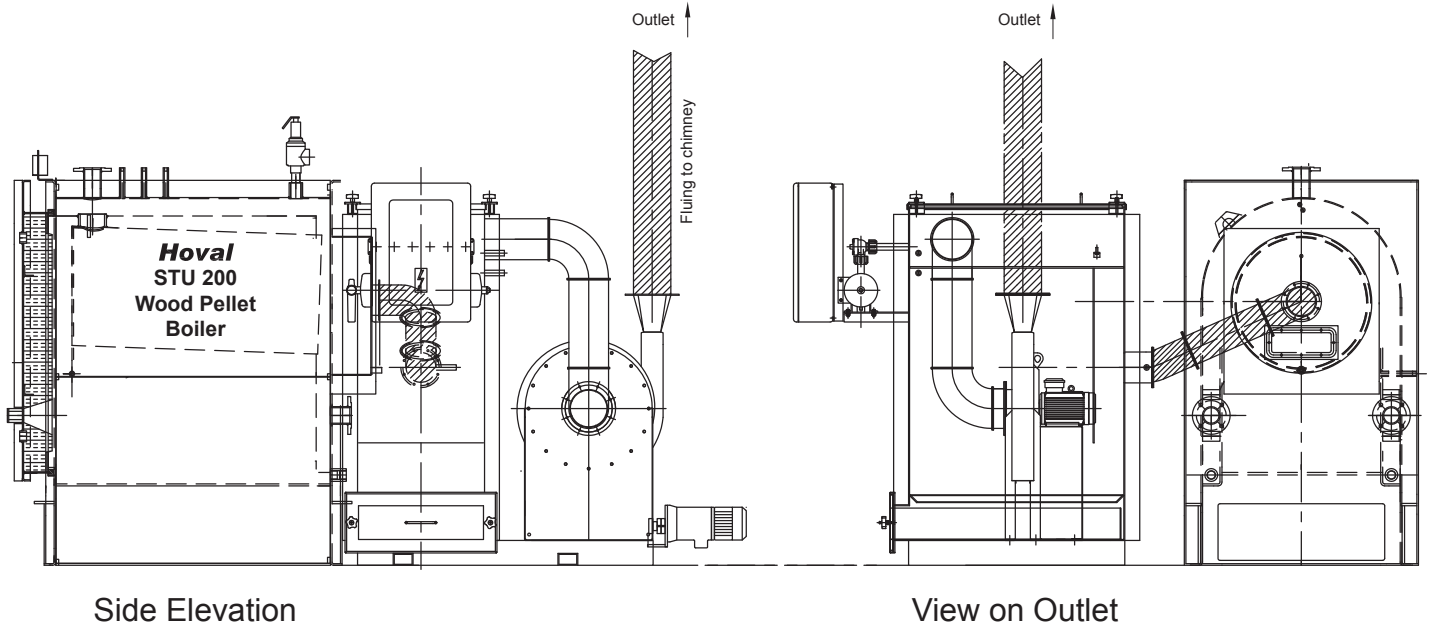

Design Guidelines

General

The Hoval STU Wood Pellet Boiler has been designed to deliver the most flexible Biomass solution.

However as a solid fuel fired appliance the boiler must be integrated with a bulk pellet fuel store to deliver the most effective design or solution. Therefore the design of the store and the connecting automatic pellet feed system should be considered at an early stage in the proposed installation of the STU wood pellet boiler.

In addition in common with all solid fuel fired boilers optimum combustion conditions are achieved when the boilers are allowed to fire as continuously as possible. The STU combustion system allows some turndown but it is important that the model selected matches the anticipated load likely to be placed on the boiler such that excessive on/off cycling is avoided. In particular consideration should be given to likely seasonal variation when applying the equipment to a space heating application.

As a rule the STU wood pellet boiler DOES NOT require the installation of a buffer or accumulator vessel in the boiler primary circuit. However the inclusion of a small buffer vessel in the system design can help to reduce boiler cycling and allows more continuous operation if significant load variation is expected. Alternatively better boiler size matching or a cascade of boilers should be considered to deliver the required turndown.

Hoval can offer a suitably sized buffer or storage vessel to match installed boiler output to anticipated loading.

Fuel Storage

With regard to the bulk storage or wood pellet fuel store the following simple guidelines offer advice to assist in the design and sizing for a successful installation.

A bulk wood pellet fuel store should be located as close as possible to the biomass boiler(s).

The design of the fuel store and the recovery of the pellets from the store and the subsequent transfer of the fuel to the boiler should be kept as simple and most straightforward as possible. Tall thin storage – such as purpose design silo's – often represent the most effective way of storing wood pellet fuel and can lead to the best use of a given storage volume. The angle of the discharge cone from such a silo would typically be 60° to ensure complete mass flow from the store.

A possible alternative to a storage silo would be a bespoke build bunker store. These typically require a larger floor area and are less effective in terms of the available recoverable volume of fuel. Some profiling of the bunker base should be considered – minimum angles of 45° should be adopted if profiling bunker – which will significantly reduce the volume available for the storage of pellet fuel.

The natural angle of repose of the fuel will vary depending on the quality of the wood pellet (see below) but will typically be greater than 45°. Again this can significantly reduce the recoverable volume available in the pellet store.

Whichever fuel store design is adopted it must be such that it:

- Keeps the fuel dry – water ingress will cause the pellets to fall apart and block handling equipment.
- Is located as close as possible to the boiler.
- Has adequate vehicle access – to allow easy bulk delivery.
- Is fitted with appropriately sized delivery pipe work.
- Bulk fuel deliveries would normally blow fuel into store via a delivery pipe.
- Delivery pipe work/bunker design should not cause undue fuel breakage during delivery.
- Is sealed to prevent possible dust nuisance.
- Conveying air used for fuel delivery needs to be filtered prior to discharge.
- Is sized to suit boiler load and likely bulk delivery payload.
- May need to be behind a fire rated wall if inside the plant room (check with Building Control).

All solids have a natural angle of repose. This is the angle formed by the fuel remaining in the bunker as it is removed from the bottom without any outside interference, agitation or mechanical recovery. The angle is a function of the size distribution of the solid and can vary depending on the fines or dust content of the fuel concerned. A good quality wood pellet fuel containing little or no fines will have an angle of repose between 45° and 50°. This angle increases as the fuel quality deteriorates and can approach 90° if the fuel contains a high percentage of fines. From this it follows that the design of the fuel store should be such to avoid 'dead volume' and that pellet handling – especially during delivery – should be sympathetic to pellet quality to avoid excessive fuel degradation.

Pellet recovery from the fuel store would typically either be via Pick-up auger(s) angled into the bunker or directly from the outlet of a coned purpose built store or silo. From the bunker or silo the wood pellet fuel is delivered to the transfer box of the stoker.

THERE SHOULD ALWAYS BE SUFFICIENT PELLETS WITHIN THE STORE – TAKING ACCOUNT OF POSSIBLE DEAD VOLUME – TO ENSURE THAT PICK-UP AUGER(S) ARE ALWAYS COVERED WITH FUEL.

Design Guidelines

Fuel Store Sizing

There are 3 key factors that influence the size of the pellet store.

1. Available Space - usually adjacent to or close to boilers - taking account of best use of that space.
2. Estimated Fuel consumption.
3. The required frequency of delivery - or the size of delivery anticipated.

For Design purposes the following can be used as indicative:

1. Bulk density or Volume of Wood Pellet Fuel;
 - Good quality wood pellet fuel will occupy approximately 600kg/m³
 - Angle of repose of good quality fuel approx 45° - 55° - which impacts on recoverable volume in bunker.
2. Fuel Consumption;
 - As an indication the maximum fuel consumption (kg/hr) would be 0.23 x Max Output of the Biomass boiler (kW).
 - Actual fuel consumption would be estimated based on the loading placed on the boiler.
 - Wood Pellet fuel store to be sized to accommodate a minimum of 10 - 15 days anticipated fuel use.
3. Delivery Size;
 - The fuel supplier will have preferred bulk delivery sizes - based on payload of vehicle employed.
 - Store should be sized to accommodate minimum delivery size.
 - First Fill delivery could be larger than subsequent deliveries. Accounting for possible dead volume within the store and making allowance for small working stock needed while waiting for a delivery.

Consider the possible use of load cells or level probes within the bunker to indicate fuel used.

Hoval can offer a number of silo based fuel store options or advise on most appropriate use of available space for a bespoke build fuel store.

Entry to Fuel Store

A confined space permit to work system should be put in place by the operator, to safely control access and egress into the fuel store itself.

Typical Plantroom layouts

The following examples illustrate different ways STU boilers can be integrated with an appropriate pellet store. These are not to scale and should not be used as a detailed design guide. They are intended as an indication of possible solutions only.

Legend

1. Silo - See notes on individual drawing for specification.
 - (a) - Areas of dead volume.
 - (b) - Slots, active pick-up locations.
 - (c) - Gate valve required to isolate individual silos.
2. STU wood pellet boiler.
- 3a. Flexible auger - Note requirements for long radius bends (1.5-2m). Note maximum length of 15m.
- 3b. Angled pick-up auger - Max length 4.5m - Angled to deliver pellets into the top of the transfer box, angled to suit the orientation of the transfer box and fuel store but note access (withdrawal) requirement.
4. Stoker transfer box, with motorised burn-back protection damper.
5. Stoker delivery auger.
6. Silo fill pipe.
7. Conveyor air discharge.
8. Chimney.

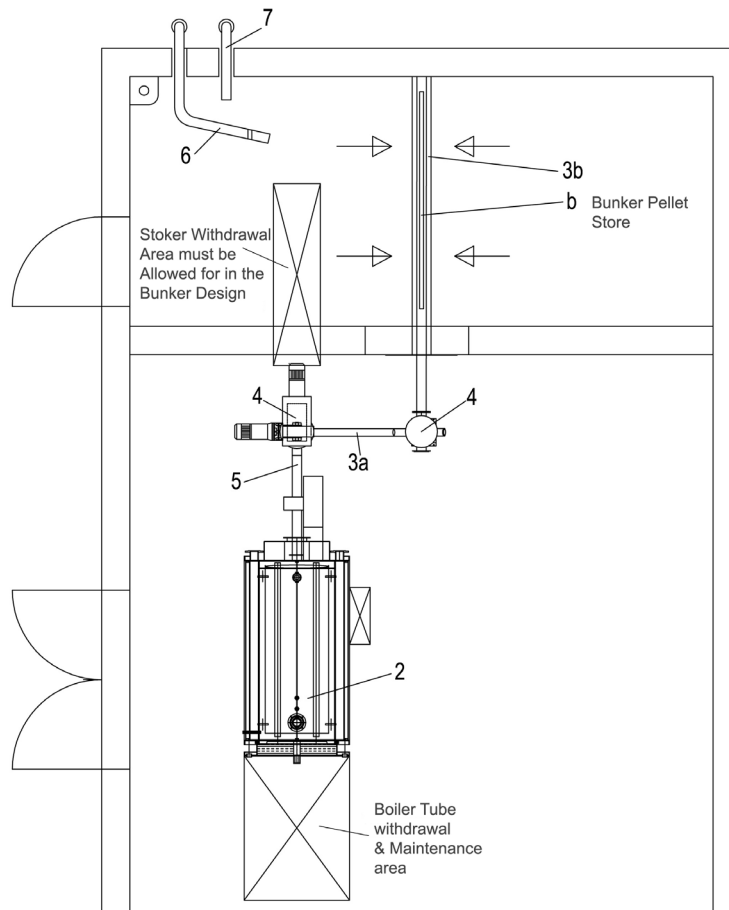

GENERAL ARRANGEMENT OF
A BOILER AND BUNKER
PELLET STORE

Typical Plantroom layouts

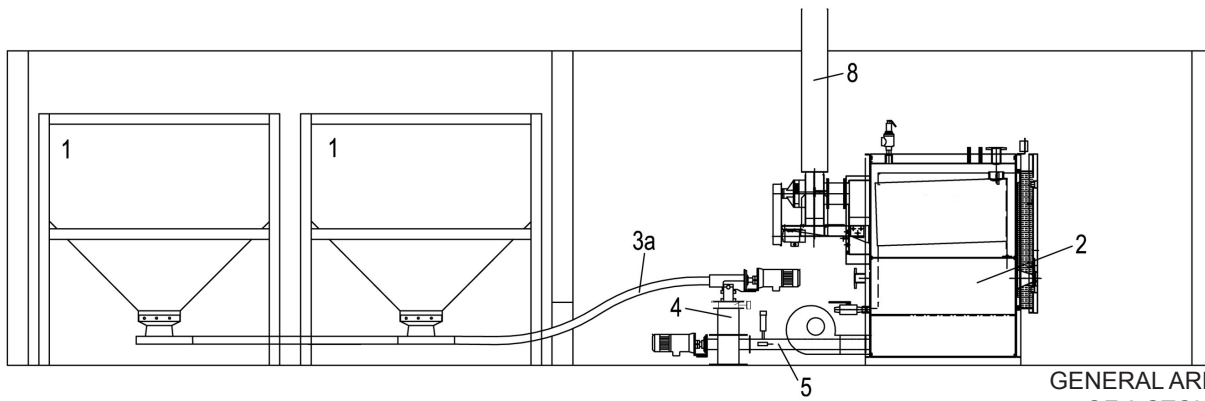
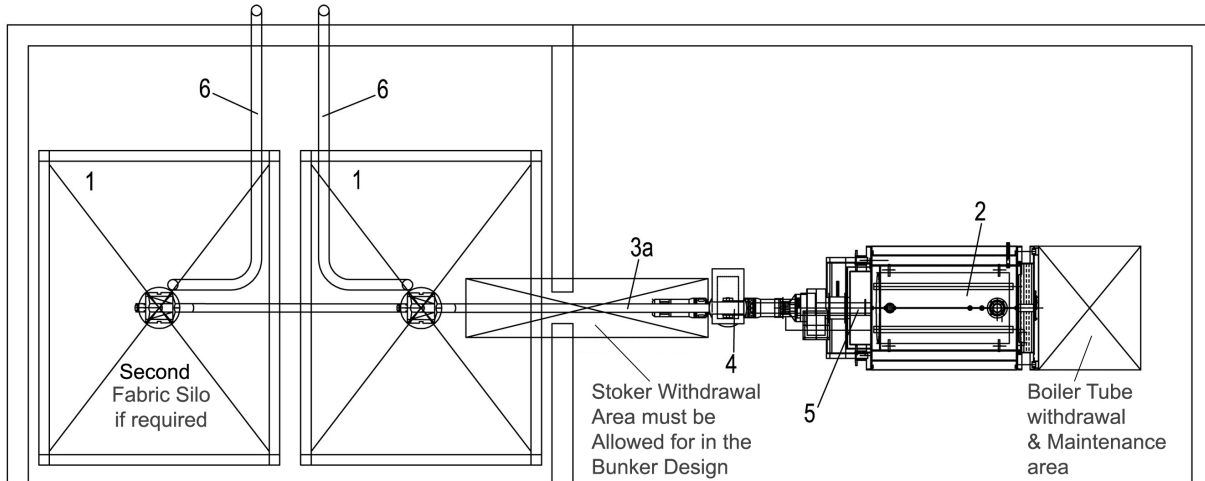

GENERAL ARRANGEMENT OF A STOKER AND A FABRIC SILO.

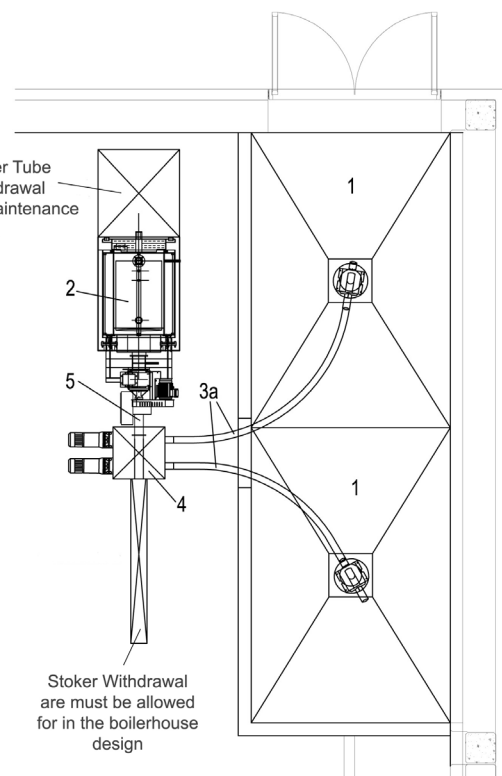
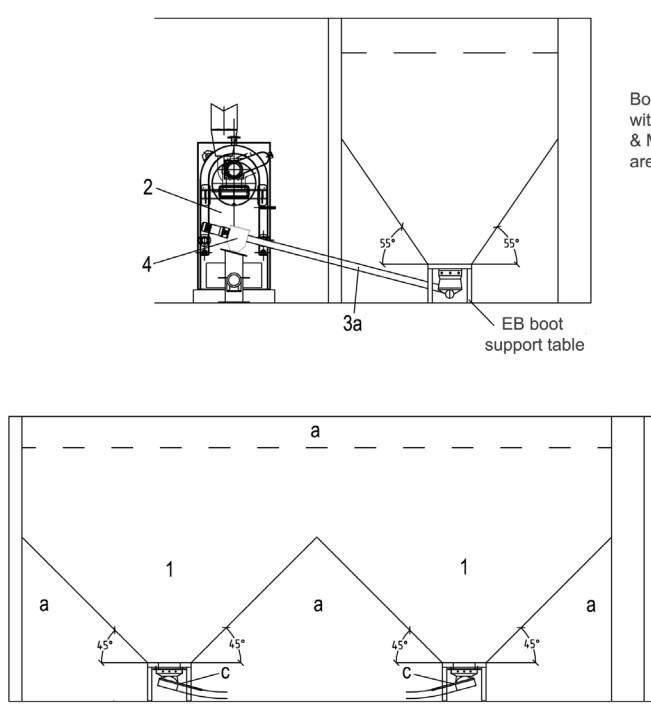

GENERAL ARRANGEMENT OF STU BOILER WITH TWIN EB BOOT TABLES AND PROFILING

Typical Plantroom layouts

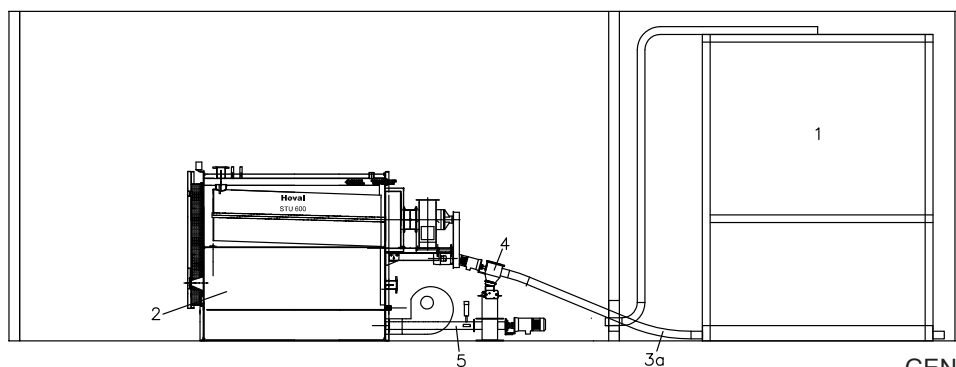
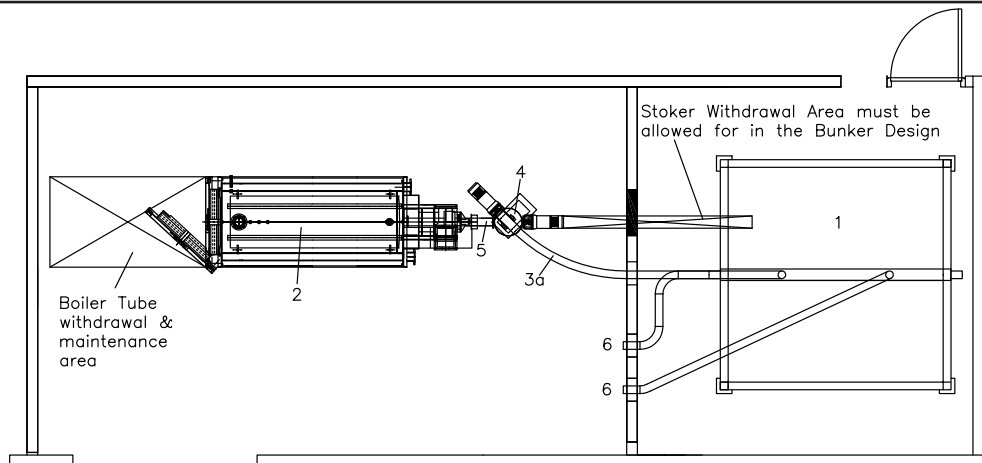

GENERAL ARRANGEMENT OF STU BOILER AND A FABRIC TROUGH BUNKER

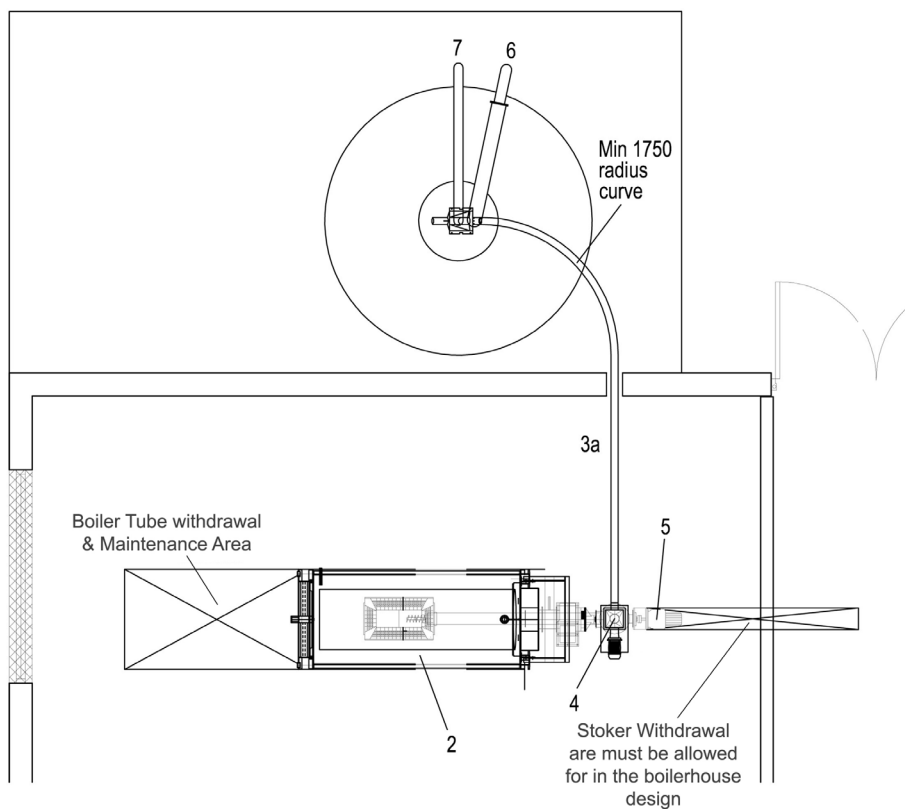

INDICATIVE LAYOUT OF STU BOILER WITH GRP SILO

Boiler door handing

Boiler door handing

As standard the boilers are fitted with hinges on the right hand side when viewing the boiler from the front. If instruction is given at the time of placing the order this can be switched to a left hand hinge arrangement. Alternatively, boilers can be handed on site by following the procedure below:

Changing the door hinged side

It is recommended that the following procedure is carried out:

- 1) On the opening side, screw the locking nut until it is tight against the back of the door boss.
- 2) Remove top right and bottom left door nuts and swap over. Tight up.
- 3) Remove top left and bottom right door nuts and swap over. Tight up.
- 4) Ensure that the lock nuts on the new hinge side are fully tightened.
- 5) Loosen locknuts on the new opening side so that a seal is obtained all round the fibre joint.

Important

- Always have two nuts tightened to prevent the door falling.
- It is essential that the door seal is in place correctly after closing the door every time. Replace the joint if in doubt and check there are no fumes escaping.
- Relocate the door microswitch to the new opening side of the door.

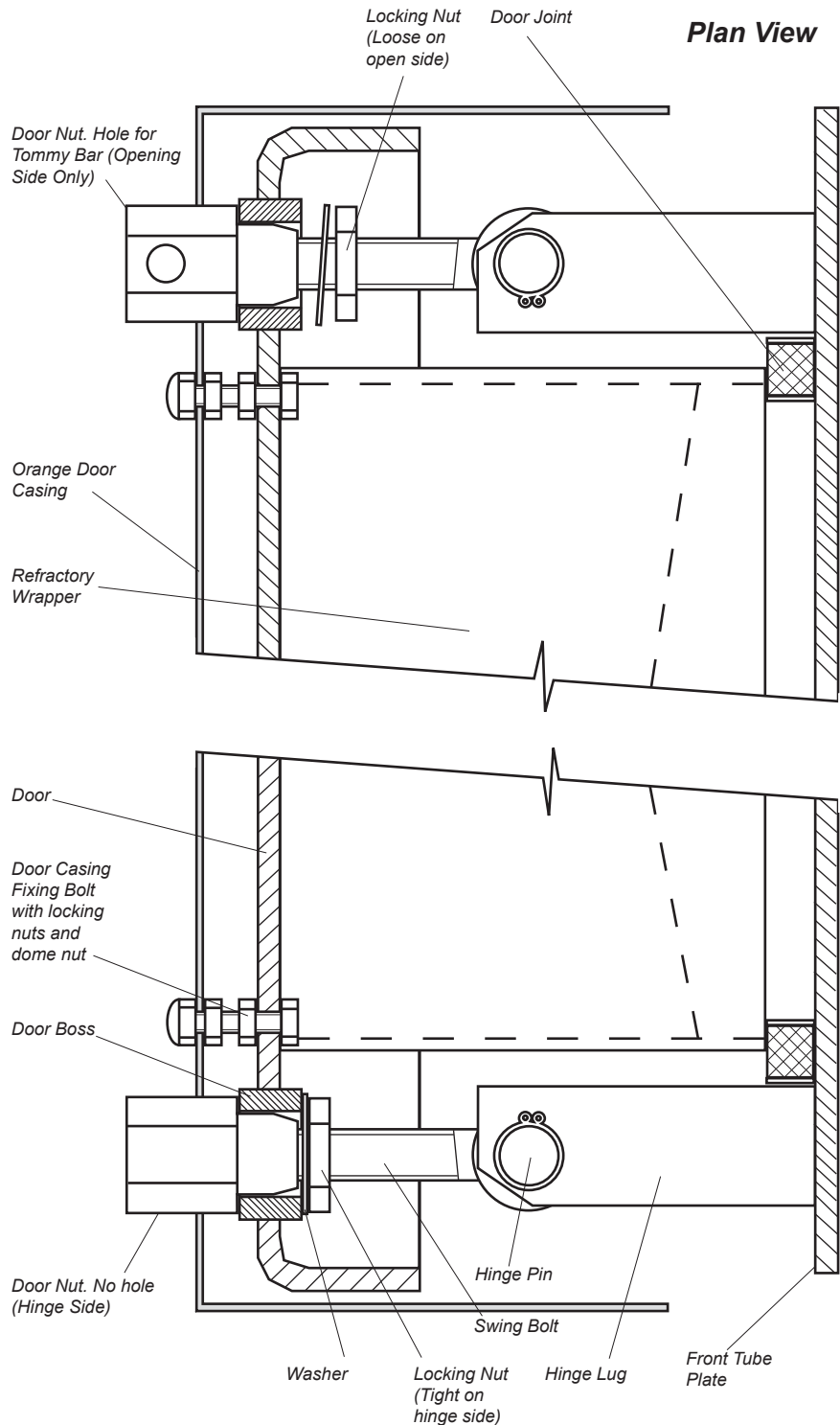

Boilerhouse Ventilation

Boilerhouse ventilation should conform with the relevant British Standards, Codes of Practice etc.

Natural Ventilation - General Guidelines

The permanent ventilation of the boilerhouse (not including doors and windows which may be closed) is essential.

Boilerhouse ventilation serves two essential purposes. Firstly it permits combustion air to flow freely to the stoker(s) from outside the building and secondly it maintains a reasonable temperature level within the plant room.

Heat released from the boiler, the piping and the flues should not increase the boilerhouse temperature above 30°C.

Air Inlet Requirements

It is preferred that fixed air openings are provided at high and low levels adjacent to the boiler front.

Free inlet area of louvres required for ventilation and combustion air should be based as the following:-

6.5cm² per kW output at low level and a further 3cm² per kW boiler output at high level.

Air inlets and ventilation outlets are best disposed at low level and at high level so that air convection across the boiler(s) will ensue. Preferably the high level opening should not be too close to the low level opening such that any short circuiting of air without providing adequate ventilation can be avoided.

Where suitably sized louvres are utilised over the boilerhouse door, louvres over the full door height are satisfactory.

For boilerhouses below ground level, arrangements should be made to induce fresh air into the boilerhouse where a natural flow of air is restricted by the buoyancy of air leaving higher level openings.

Air Supply by Mechanical Ventilation - General Guidelines

The supply of air to a space housing the boiler by mechanical means should be mechanical inlet with natural or mechanical extraction. Mechanical extract ventilation with natural inlet must not be used.

Any mechanical means of entering air into a basement boilerhouse should have a balancing outlet so that the air pressure in the boilerhouse does not exceed 12.5 Pa.

Where mechanical inlet and mechanical extract system is applied, the design extraction rate should not exceed one third of the design inlet rate.

Ventilation must continue in kindle mode.

Note: All air inlet and extract fans should be fitted with automatic controls interlocked with the boiler controls to give a safe shutdown or lockout in the event of the inlet or extract air flow failing.

Open Vented / Pressurised Systems

Open Vented Systems

A primary make up water and expansion tank is required for open vented systems. With low head on calorifier primary system, Hoval Technical Department should be consulted.

The cold feed pipe should be connected into the return water piping on the boiler side of any valve.

An open vent pipe should be taken off the boiler flow pipework before the boiler isolating valve. The vent pipe should be installed with a continuous rise to a position over the primary feed tank.

Pressurised Systems

For independently pressurised systems the flow connection must be fitted with an automatic air vent, a safety valve (sized to the relevant British Standard) and a pressure switch or where applicable individual boiler pressure limiter(s) as outlined below. No intervening valve is permissible between the safety valve and boiler connection. The pressurisation unit control should also be interlocked with the boiler(s) controls to safely close the stoker(s) down in the event of a malfunction.

Pressure limiter (in accordance with BS EN12828:2003 clause 4.6.2.2.2 - Heating Systems in Buildings).

For **STU models 350 to 1000**, each boiler should have an associated pressure limiter device fitted in the system pipework, as close as possible to the boiler itself (provided by the installer - not supplied, fitted, or wired by Hoval).

If the operating pressure of the heating system exceeds the given pressure limit, or in the case of auxiliary power interruption, the pressure limiter shall shut off the heating equipment and interlock it against restarting. The pressure limiter shall be adjusted so that it responds before the safety valve(s) operate.

Flues and Chimneys

Guidance for sizing flues and chimneys is given in CIBSE and HVCA guides and also Hoval Technical Data Sheets. Flues should conform to the relevant British Standards, Codes of Practice etc.

IMPORTANT

A condensate drain point is provided in the boiler flue outlet box and this should be piped to drain via a drain trap to prevent flue gases escaping. No isolating valve should be fitted in this pipework (plastic fittings not suitable).

General Guidelines

- Individual boiler chimneys and flues should be used.
- The chimney/flue design should encompass the minimum number of bends - any bends should be swept - avoid excessively long horizontal runs and if possible have the flue enter the main chimney riser at an angle of 45° to minimise the flue duct resistance.
- Flues should not be less in diameter than the boiler outlet connection size.
- The flue design will be such that the chimney height should provide sufficient buoyancy to give a **negative pressure condition of between 10 and 30 Pa at the boiler flue outlet**. The chimney and flue should, under normal firing conditions, provide a draught at the boiler outlet.
- Common flue headers must be avoided.
- Steps should be taken to prevent or minimise condensation forming within the flue by using twin walled insulated systems.
- Adequate doors should be provided in flues and chimneys for cleaning and inspection purposes. This is particularly important on any horizontal section. **The flue should include a pressure relief and / or draught stabiliser fitted adjacent to the boiler flue connection.**
- Flues should be supported independently to prevent any undue weight and forces due to expansion being transmitted to the boiler outlet connection.
- Fuel Quality Requirement. The design of the combustion system is dependant on using the correct quality wood pellet fuel. The fuel **MUST NOT** contain halogenated organic compounds or heavy metals as a result of treatment with wood preservatives or coatings.
- **Note:** Flue gas temperature at high fire may approach 200°C and the flue system should be able to safely operate under such conditions (further advice can be found at www.heatas.co.uk).

Chimney sizes and height will need to take into account the following:

- 1) **Clean Air Act.**
- 2) **Local Regulations.**
- 3) **Considerations to adjacent buildings.**
- 4) **The discharge to atmosphere of the products of combustion that may contribute to health dangers and be such to minimise the impact of the same. When used with the correct quality fuel, the STU meets the requirements of Class 3 of EN 303-5 in this respect.**

Filling the system

Recommendation

It is recommended that each system should be filled or refilled with treated water and specialist firms will be able to advise in this respect.

Check the following:

- All connections are made and tightened.
- Instrument pockets are fitted and water tight.
- Spare sockets are fitted with plugs and are water tight.
- All valves in the heating circuit are open.
- Mixing or diverting valves are opened half way, then gradually fill with water until the altitude gauge (if fitted) indicates the correct head and the header tank is filled to appropriate level.
- The installation is completely vented.
- If a pressurisation unit is installed reference should be made to the makers filling instructions and applied.
- Installation debris and any deposits from the system are not allowed into the boiler.
- The boiler is flushed out through the drain connection to ensure that the boiler is clean inside.
- A large strainer is fitted to older systems to remove deposits before the return enters the boiler.

Water treatment

There is basic need to treat water contained in all heating and indirect hot water systems, particularly open vented systems.

One millimetre of lime reduces the heat conversion from flame via metal to water by 10%.

In practice the deposition of these salts is liable to cause noises from the boiler body or even premature boiler failure. Corrosion and the formation of black iron oxide sludge will ultimately result in premature radiator failure.

Open vented systems are not completely sealed off from the atmosphere as it is essential to provide a tank open to atmosphere if proper venting and expansion of system water is to be achieved. The same tank is used to fill the water and it is through the cold feed pipe that system water expands into the tank when the boiler passes heat into the system.

Conversely when the system cools, water previously expanded is drawn back from the tank into the system together with a quantity of dissolved oxygen.

Even if leakage from the heating and hot water systems is eliminated there will be evaporation losses from the surface of the tank which, depending on ambient temperature, may be high enough to evaporate a large portion of the system water capacity over a full heating session.

There will always be corrosion within a heating hot water system to a greater or lesser degree irrespective of water characteristics unless the initial fill water from the mains is treated. Even the water in closed systems will promote corrosion unless treated.

For these reasons Hoval strongly recommend that when necessary the system be thoroughly cleaned, prior to the use of a stable inhibitor, which does not require continual topping up to combat the effects of hardness salts and corrosion.

Hoval advise contact directly with major specialists on water treatment such as Goodwater or Houseman.

Water Flow and Return Temperatures

1. The flow temperature can be adjusted to a 85°C maximum.
2. The return temperature should be controlled to be not less than 60°C at all times by the use of suitable bypass/diverting controls. Always ensure that the return pipework to the boiler is connected to both return connections equally.
3. Differentials between the flow and return should not exceed 25K. Where a differential is to exceed 25K advise Hoval as considerations are necessary and alternative solutions may be appropriate.

Important

The whole system must be thoroughly flushed with water to wash out foreign matter and impurities in accordance with CIBSE/BSRIA guidelines.

Control Details and Safety Features

In addition to the stoker control panel (see below) a boiler flow temperature gauge is fitted at the front of the boiler.

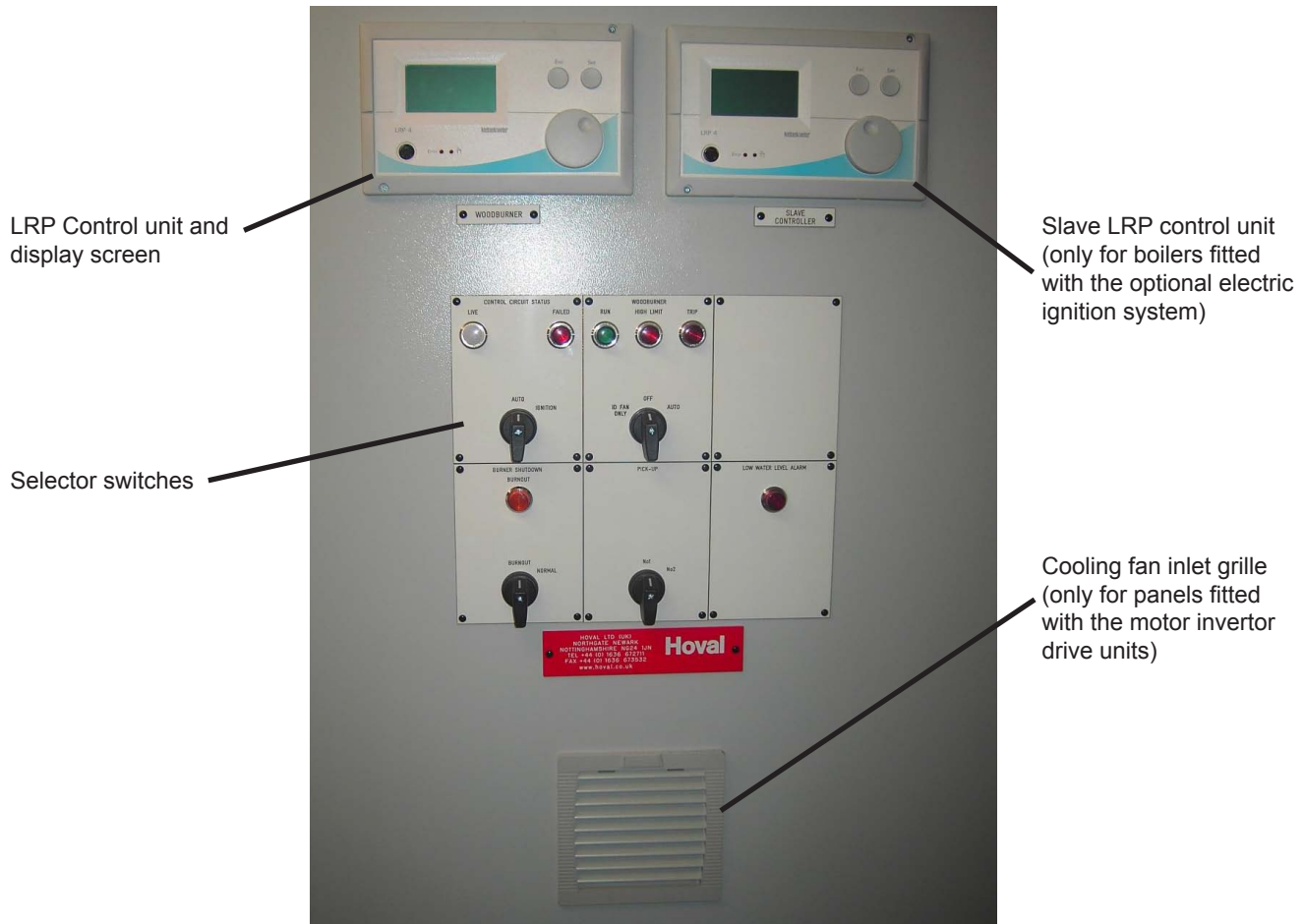

- **The stoker control panel consists of:**
 - Mains Isolator (not shown above)
 - LRP control unit and Display. Slave LRP Control unit (for boilers fitted with the optional electric ignition system).
 - Wood burner selector switch with settings ID Fan Only /Off/Auto
 - Wood burner shutdown selector switch with settings Burnout/Normal
 - Optional ignition selector switch with settings Auto / Ignition
 - Optional pick-up auger selector switch (where specified)
- **The Mains Isolator will:**
 - Electrically isolate the stoker and pick-up auger(s)
 - The isolator is provided with a lock-off facility.
- **The LRP controller and display** has a wide variety of settings available for fine control of the wood pellet-burning stoker. In normal operation only a few of these may be required to be displayed but they can be altered at the time of commissioning to suit the site conditions. The following are the most common parameters available for display:
 - Boiler Flow set point.
 - Wood pellet feed speed.
 - Oxygen set point.
- **The stoker ID Fan Only/Off/Auto switch will:**
 - Turn the stoker off when in the off position.
 - In the Auto position the stoker will be under control of the LRP and time clock or the Building Management System and will modulate to follow the load accordingly and may kindle if the set point water temperature is satisfied (includes frost protection).
 - Select the ID Fan Only position prior to opening the boiler door
- **The Burnout/Normal switch will:**
 - Normally be in the Normal position.
 - In the burnout position, the conveyor auger tube will be run out of fuel and the fire allowed to burn itself out.
- **The Auto/Ignition switch (where fitted) will:**
 - Normally be in the Auto position.
 - In the Ignition position the retort will be primed (from empty) with pellets and the ignition process started.

IMPORTANT - 3 Phase 32A 400V supply is required for stoker and control panel operation.

Control Details and Safety Features



Space for other optional selector switch.

Optional Pick-up auger(s) selector switch (not standard item)

The stoker control panel can be fitted or mounted on either side of the boiler or where requested can be supplied separately for mounting on a wall within the plant room. Site wiring will be required to connect the pellet auger feed motors, FD and ID fan motors, each must be connected via individual isolating switches that should be clearly labelled. In addition the flow temperature sensor, damper control on both FD and ID fans, burn back stat, burnback protection damper, door microswitch, combustion chamber pressure switch and lambda control will also require wiring back to the panel. This wiring is NOT generally part of the stoker installation unless arranged at the time of order.

The Stoker Control Panel also houses a series of indicator lights as follows:

- Panel Live (Orange).
- Fuse Failed (Red).
- Stoker Run (Green).
- High Limit (Red).
- Trip (Red).
- Low water level alarm (Red)
- Burnout (Orange)

Under normal operation the LRP controller monitors and regulates the boiler water temperature. In addition to this, mounted in a pocket on top of the boiler are two thermostats. The first of these has a temperature dial, which can be adjusted in the range of 70-83°C, this effectively acts as a first limit stat, and if the boiler water temperature exceeds the set temperature the stoker will shut off and will only re-fire once the water temperature has fallen. It should be set higher than the programmed water temperature setting in the LRP controller. The second stat is set at commissioning, usually 11°C above the first, and is a second or high limit stat. If the boiler temperature exceeds this limit then the stoker will shut off and the High Limit indicator will be illuminated. The stoker will not re-fire until this second limit stat is manually reset.

Under normal operation the Stoker Run (green) light should show on the control panel.

A fuse fail or a motor trip would illuminate the appropriate light - if illuminated the cause should be investigated prior to resetting.

Note: For Boilers fitted with the optional electric ignition system, a door microswitch is fitted which is linked to a "latching relay" inside the control panel. This ensures that if the electric ignition process fails, then the boiler door needs to be opened (& appropriate action taken), before the Auto/Ignition selector switch can be reset. Please follow the operating and fault finding procedures in Appendix D of this manual if this situation arises.

Control Details and Safety Features

If the High Limit is illuminated the limit stat will need to be manually reset. Allow the boiler to cool down then unscrew the protective cover over the reset button. Press the button in and replace the cover. The boiler will automatically resume operation.

Additionally the stoker control includes a number of other **safety features**, these include;

Mains isolator on control panel facia. The isolator electrically isolates the stoker and pickup auger(s). A lock-off facility is provided. The operator should employ a safe system of working before carrying out maintenance or servicing of the equipment.

Thermal safety heat exchange device. Within the waterway of the boiler there are a number of small independent heat exchanger coils. If the boiler water temperature exceeds 95°C the thermostatic valve opens and allows cold mains water to pass through the coils to quickly reduce the boiler water temperature. The cooling water exit coil should be directed to drain via a tundish.

Burn Back Protection. There is a burn back manual reset type thermostat fitted to the delivery auger set to 60°C. If the temperature of the tube exceeds 60°C then the stoker control isolates and stops the supply of combustion air through the FD fan and ceases the delivery of fuel to the transfer box. This is done by stopping any pickup auger that might be running. At the same time the transfer box burnback protection fire damper will also motor close. The ID fan is allowed to run on and a timer within the control panel allows the delivery auger to operate sending partially burning pellets back into the retort within the boiler. During this process a red light will show on the LRP controller indicating a fault along with an error message on the display. The "burnback initiated" volt free contact will also be activated. This control feature will still be active even if the woodburner selector switch is in the "off" position.

The Stoker will not be allowed to re-start until the burn-back protection thermostat is manually reset. However it is important that the cause of the burnback has been established and rectified before allowing the stoker to re-start. The condition of the burnback thermostat itself should also be checked to ensure it has not overheated and become damaged. If this is the case, the thermostat should be replaced with a manual reset type, range 60 - 90°C.

Note: In the event of a continuing back burn condition along the delivery auger, due to a mains failure, a delivery auger fault, or the ID fan continually running, then there is a separate thermostat fitted to the auger tube connected to a **water dump**. This is pre-set at 95°C and ensures safe stoker operation in the event that burn back protection, as described above, cannot take place ie, the water extinguishes the burning pellets. We recommend that the burnback thermostat is always replaced after the water dump has been activated.

Although the water level in the water dump container is fitted with a level monitoring float switch, we still recommend that the water level is physically checked on a weekly basis. This should be within 50mm of the top of the container. Always replace the cap after checking and / or topping up.

In the event that the water dump has been activated, the low water level alarm (red) light will be illuminated on the control panel facia and the stoker will cease to operate. Please contact Hoval Service if this situation arises.

Power interruption. In the event of a power interruption, the motorised burnback protection damper will automatically close (fail safe). It is possible (as pumps maybe off) that the independent heat exchanger cooling coil device, as well as the high limit thermostat may be activated. The cooling coil thermostatic valve will reset itself as the water temperature within the boiler falls, but the high limit thermostat will need to be manually reset to allow the stoker to restart when power is re-established. The fire damper will also open automatically when the stoker is required to operate. A firebed burn-back will not occur unless the power interruption is prolonged (greater than one day's duration). If this happens the water dump device may also be activated to extinguish the burning pellets.

Oxygen High. Should the fire go out, the oxygen sensor in the flue reads 20.9%. If this condition does not change for 30 minutes then the stoker is switched off and no more wood pellets will be fed into the boiler. A red light will show on the LRP and an error message will be displayed.

Oxygen Low. If the oxygen sensor reads less than 3% for a 10 minute period then the stoker will shut down, again a red light will show and an error message will be displayed.

Voltage/Phase relay. Should the stoker control sense a reduced voltage supply or if the phases are altered then the LRP will signal an error and display a message accordingly.

Space Requirements

Where ever possible space should be left around the boiler to enable all parts to be examined and the cubicle casings to be fitted or removed easily allowing for stoker maintenance. Note access requirements in front of boiler for cleaning etc and where necessary auger withdrawal from tubes.

Additional points

When pipework is being connected to the boiler care must be taken not to damage the casings, which are not designed to be stood on. Design of pipework runs and the use of expansion joints as required. External weight or thrust from system pipework attached to the boiler should be avoided by careful design of pipework runs and the use of expansion joints as required.

Control Details and Safety Features

Important

The LRP control requires the installation of a modulating sensor in the boiler shell as shown opposite (fig 1). This will be fitted at the time of site assembly.

Power-Up

When the control panel isolator is turned on the LRP 4 will power up, the two LED lights on the front will flash until the unit has finished initialising.

The Controller Menus

The HRP/LRP controller range has a very easy to use interface. Its layout has been designed to simplify user tasks by grouping specific functions into groups. Setpoints, time programs and manual override are easily found by scrolling through the menu structure.

The modifications that each user can make to the existing program will depend on the access level that the user has been given. There are four user levels, level 1 is the lowest and level four is the highest. As the level increases the access rights increase by building upon the previous level features:

- Level 1 - View parameters and manually set plant status only.
- Level 2 - As Level 1 and change times/schedules/set-points/view menus.
- Level 3 - As Level 2 with change all settings and view all parameters.
- Level 4 - As Level 3 with edit menus and configure the controller strategy.

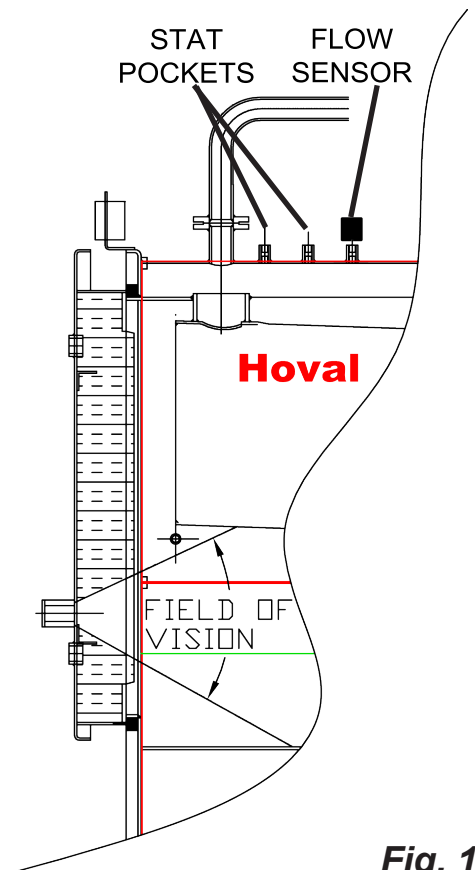
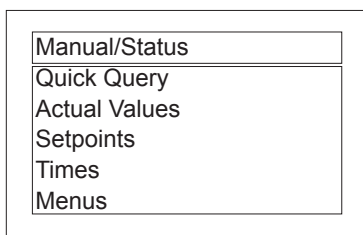

Fig. 1

To change user level hold the ESC key down for 5 seconds and then enter your password. Your password will be given to you by your installer

The User interface is menu driven so you must select the option that you need to use and press SET to move into that option.

Turn the wheel to select the function you wish to perform. Press SET to move into the menu. Press ESC to move out of the menu.



The pre-defined menu options are as follows:

Manual/Status	Enables users to override plant and check current status of plant/alarms.
Quick Query	A tailored screen for the end user to check common settings.
Actual Values	Check the current condition of sensors and switches.
Setpoints	View and/or modify the controller setpoints.
Times	Check or modify the controller time programs (Not used if the plant is under a B.M.S. control).
Menus	View the configured control Options.
Control	View the control strategy.
Configuration	Load new macros and configure the controller communication parameters.

The menu options above may change depending on the type of controller you are using and the access level that you have.

Control Details and Safety Features

To Reset Alarms

When a fault has occurred the 'Fault' light will be illuminated on the front of the LRP unit.
 Press 'Set',
 Highlight the 'Manual/Status' option on the display,
 Press 'Set'.

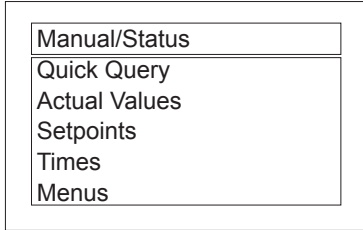

The fault(s) will be recorded on the first row.
 To cancel this light the fault firstly has to be rectified (e.g. limit thermostat has to be reset),
 Press 'Set' to confirm fault,
 Press ESC to return to front screen (The unit will return to the front screen on its own after a short time if ESC is not pressed).

Although the fault has been cleared it has been recorded for future reference. If the fault re-occurs then a qualified engineer should be contacted.

Quick Query

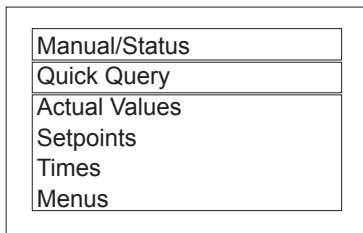

The Quick query screen can be configured to suit your personal requirements by your installer. This screen should be your first display that you reference when you are using the controller.

The parameters shown here will be directly related to your plant applications and requested access levels to suit your experience. These parameters may be changed by you e.g. if a setpoint is shown it may be changed here. Trend curves may also be enabled and viewed from the Quick Query screen.

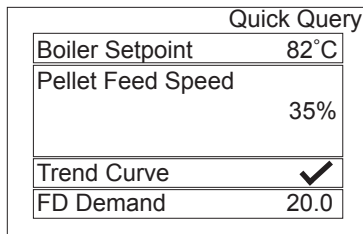

A small tick will be shown next to a parameter that has a trend curve enabled. Any analogue or digital value can be logged. A small graph symbol will appear next to the logged values when in normal menu to indicate that a trend curve is running. Two trend curves can run on a single controller at any one time. The trend information becomes circular after one weeks' data has been stored. This data can be sent to a CS140BMS system if connected/available.

Zooming Into and Turning a Trend Curve Off

The trend can be disabled by viewing the Trend curve and pressing 'SET'. A small menu will be shown where you can select the following options:

- Reduce Zoom out of the display by increasing the time scale.
- Enlarge Zoom into the display by reducing the time scale.
- End Trend Stop recording values for this parameter.

Control Details and Safety Features

Parameters within the Quick Query screen

Boiler Setpoint	(All Levels)	Temperature to which the stoker will modulate.
Boiler Off Setpoint	(All Levels)	Temperature to which the boiler will switch off.
Min. Feed Speed	(Level 4)	Lowest pellet feed rate during modulation.
Max. Feed Speed	(Level 4)	Highest pellet feed rate during modulation.
Wood Quality PB	(Level 4)	This will adjust the rate of modulation on temperature rise.
Trickle Feed Delay	(All Levels)	This indicates if the kindle delay time is on or off (I = On, O = Off).
Trickle Feed Trim	(All Levels)	This indicated if the kindle feed is on or off (I = On, O = Off).
Pellet Feed Speed	(All Levels)	This indicates the current pellet feed rate.
Oxygen Setpoint	(All Levels)	This is the required oxygen content level in the Flue.
FD Demand	(All Levels)	Indicates the demand for the FD Damper to open or close.
Oxygen P-Band	(Level 4)	Used by FD Demand (DO NOT ALTER)
Oxygen I-Action	(Level 4)	Used by FD Demand (DO NOT ALTER)
Oxygen Measurement	(All Levels)	Actual oxygen measurement in the flue.
Boiler Flow Temp	(All Levels)	Actual boiler output flow temperature
Delayed Plant Demand	(All Levels)	Indicates whether the pellet feed time is called to run. (I = On, O = Off).
Delayed ID Fan	(All Levels)	Indicated whether the Boiler Fan is called to run (I = On, O = Off).
Delayed FD Fan	(All Levels)	Indicates whether the Stoker Fan is called to run (I = On, O = Off).
Trickle Feed Rate	(Level 4)	This sets the pellet feed time during kindle.

Altering the Boiler setpoint

- Select the Quick Query menu option and press 'SET',
- Select Boiler Setpoint,
- Press 'SET' to confirm,
- Turn the wheel to select the required temperature (Requires setting 2°C below Boiler Off setpoint),
- Press 'SET' to confirm then press ESC.

Altering the Boiler Off setpoint

- Select the Quick Query menu option and press 'SET',
- Select Boiler Off Setpoint,
- Press 'SET' to confirm,
- Turn the wheel to select the required temperature,
- Press 'SET' to confirm then press ESC.

Actual values

Used by your installer.

Set Points

Used by your installer.

Times

A boiler Management System (B.M.S) will normally control the plant, therefore the time program within the unit is not assigned.

Altering the Unit time

- Press 'SET',
- Select the Time menu option and press 'SET',
- Select Set time of Day,
- Press 'SET' to confirm,
- Select time,
- Press 'SET' to confirm,
- Turn the wheel to select the required time,
- Press 'SET' to confirm.

Menu, Control and Configuration

These are menu options used when programming and should only be altered by your installer.

Volt free Contact signals

As standard the following six off, volt free contact signals are available to the BMS from the boiler control panel:

- FD fan running (stoker running normally)
- Stoker tripped
- Boiler high limit
- Stoker Isolated
- Burnback thermostat initiated
- Low water level in water dump container

(Wiring to the BMS by others)

Commissioning

It is essential that the following points are completed by the Heating Engineer before commissioning is requested through Hoval.

- System full of water and vented.
- Boiler flue box drain pipework is fitted.
- Heating load available e.g. pumps working.
- Fuel supply sufficient.
- Electrical connections made and correctly fused.
- Correct boilerhouse ventilation.
- Other manufacturer's equipment has been installed & commissioned as necessary, e.g. pressurisation units.

If the above are not completed and commissioning is unable to commence, clients will be charged for the abortive visit.

Generally Hoval approved engineers will assemble the stoker and fuel feed system at site prior to commissioning.

However before the boiler and stoker can be fully commissioned it is essential that the following are completed by the installer to ensure the equipment can be set to work in an effective manner;

- System full of water and fully vented.
- Both boiler return connections are connected to a common inlet header
- Boiler flue box drain and drain trap pipe work fitted.
- Spiral turbulators fitted to all smoke box tubes.
- Sufficient heating load available to run boilers at full load for the commissioning period - typically several hours.
- All electrical connections made and correctly fused.
- Boiler house is adequately vented.
- All other manufacturers equipment has been installed and commissioned (e.g. pressurisation units).
- An automatic air vent is fitted at high level on the flow pipework connected to the boiler.
- A suitable safety valve has been fitted directly onto the boiler together with associated discharge pipework. No isolating valve should be fitted between the boiler and the safety valve.
- Sufficient mains cold water supply available for the safety thermal heating coils together with drain pipework to local tundish.
- Sufficient wood pellet fuel in the bulk store for the duration of the commissioning period.
- Indicative analysis of the wood pellet fuel to be fired.

If the above are not completed and commissioning is unable to commence clients will be charged for the abortive visit.

Hoval approved Service Engineers normally commission all new boilers and they will check the following;

- The boiler and system is filled with water and vented, including circulation pumps.
- The boiler flue box and drain pipe work is fitted.
- Any independant pressurised system is operating correctly. Suppliers of the equipment should adjust their equipment during commissioning.
- Provision of individual boiler pressure limiter device(s) for models STU 350 to 1000 (page 23 refers)
- Check that any dampers in the flue between the boiler and the chimney (if fitted) are in the open position and locked open if manually operated and if electrically operated that the stoker is interlocked electrically to prevent operation until the damper is open.

Operating Instructions

Important Notes for the Boiler Attendant

Day to Day Operation

The STU Wood Pellet boiler has been designed to enable the effective controlled combustion of wood pellet fuel without excessive manual input. The stoker will automatically adjust the firing range to match the load with damper control on both the forced and induced draught fans. Continuous O₂ monitoring of the flue gases ensures close control of combustion along with clean and efficient operation. It will respond quickly to changes in load and the standard stoker control package includes an airless kindle (or boiler 'stand-by') feature when heat is no longer required or the control thermostat is satisfied.

In kindle mode a small ignition source is held within the retort of the stoker and this can be used to bring the boiler back to full fire within a few minutes without any outside or manual attention. In kindle mode fuel usage is negligible and there is no heat to dissipate. The STU boiler can usually be held in this condition for up to 72 hours.

In common with most solid fuel boilers optimum combustion conditions are achieved when the boiler is allowed to fire continuously over extended periods and therefore Hoval recommend that an appropriately sized STU wood pellet boiler is selected to meet the likely required load.

The stoker control is designed such that the modulating fuel feed and the pre and post run of both the FD and ID fans ensures smokeless operation.

Fuel Supply to Stoker

Always ensure there is sufficient wood pellet fuel covering the pick-up auger or available at the outlet of the pellet storage silo.

Where fitted, the slot of the pick-up or bunker worm must ALWAYS be covered with adequate supply of fuel; it should be checked routinely during operation. Failure to keep an adequate supply of fuel over the pick-up will result in the boiler going out. The bunker must be secure and should prevent any foreign material and/or water entering the stoker system.

IMPORTANT: The pick-up screws should be isolated before entry to bunker and correct health and safety procedures followed when entering any confined space.

Provision should be made to prevent any dust or fuel escaping the bunker-particularly during the delivery, the bunker should be fitted with a ventilation grille and filter, this is to allow a discharge path for the conveying air used during delivery. **The filter will require cleaning after each fuel delivery;** this can be done using either a brush or vacuum. (Spare filters are available). **Boiler should be switched OFF during a pellet delivery.**

Check the level of fuel in the bunker on a regular basis - Especially as the weather gets colder. Trim fuel if required. Check with fuel supplier and establish likely delivery lead time.

Start Up/Ignition

With a cold 'Boiler-Out' condition there are two possible options for lighting the boiler, either by manual introduction of an ignition source to a primed or filled retort, or, as an option, an automated priming system followed by electric ignition. If fitted the Electric Ignition system is initiated by an additional switch AUTO/IGNITION fitted on the Stoker Control Panel.

Having fired the Boiler and placed it into operation the boiler would normally kindle or sit in 'stand-by' when not required or when the connected load has been satisfied. Hoval recommend that it can be held in this kindle condition for up to a maximum of 72 hours. **If it is anticipated that the available heating load would lead to any boiler kindling in excess of this period then it should be switched off.**

More detailed description of both methods of Ignition as Follows;

Electric Ignition (Optional)

With this option the Wood Pellet Fuel within the retort can be brought to ignition using an electric hot air jet to initiate the combustion process. The source of the hot air is a 3kW electric hot air gun mounted within the plenum of the stoker, which operates for a short controlled period and directs hot air into the filled retort onto the wood pellet fuel until combustion is established.

To set in operation

1. The Operator MUST ensure that the correct shut down and switch off sequence has been followed (this is described below).

Provided that the boiler has previously been shut down correctly there will be little or no pellet fuel within the retort or the Delivery Auger of the stoker. It is therefore **IMPORTANT** that the Operator CHECKS the retort visually prior to starting the Electric Ignition sequence to confirm that the retort is **CLEAR OF ANY FUEL**. This will involve opening the boiler door briefly to check the condition of the hearth and retorts.

The above process is necessary to avoid overfilling or over feeding the retort prior to the introduction of an ignition source. Ensure that all local Isolating switches associated with the stoker are 'ON' and the stoker Control panel has power to it.

2. On the Stoker Control panel set the AUTO/IGNITION switch to the ignition position. The Wood Burner Switch (ID FAN/OFF/AUTO) on the Stoker Control panel should be set at Auto.

Sequencing of boilers under BMS control.

When a bank of boilers are sequenced to operate under the dictates of a BMS control system, it is very important that on-line boilers are "properly" matched to the available heating load at any one time. This will avoid too frequent cycling of the stokers as they stop and start (introducing cold pre & post purge air into the boiler each time this happens). Over time this can result in the boilers suffering from thermal shock and premature failure of the pressure parts.

Operating Instructions

With the AUTO/IGNITION switch in this position and with a demand signal calling for operation of the Boiler and with the Flue Gas Temperature registering <50 °C, then the following sequence for Ignition occurs;

- Run Pellet Feed systems to prime or charge the retort
- This may take several minutes to complete and is site specific and pre programed on commissioning
- Hot Air Ignition Gun switches ON (A)
- ID Fan switches ON
- Wait for a set period (Approx 5 minutes)
- Hot Air Ignition Gun switches OFF
- Wait for a period (approx 10 minutes) to achieve the required Flue Gas temperature
- If the Flue Gas Temperature >50 °C then
- Switch ON FD fan
- Wait for a set period (approx 10 minutes)
- Stoker Pellet Feed system operates, initially on Low Fire, before normal modulation based on demand.
- If after priming the retort and running Ignition Gun/ID Fan the Flue Gas temperature remains <50 °C
- The Hot Air Ignition sequence (from (A)) is re initiated
- If after a further attempt (i.e. the 3rd) to establish combustion, the Flue Gas Temperature remains <50 °C then the Stoker Control switches the stoker/boiler off.

If the Flue Gas Temperature is >50 °C when the demand signal is received the system will not fire the Ignition gun.

3. IMPORTANT. Once the fire has been established the operator should set AUTO/IGNITION switch on the Stoker Control Panel to AUTO position.

4. If after the above the boiler has failed to light or combustion has not been established then the operator **MUST NOT RESET** the AUTO/IGNITION switch to Ignition without taking appropriate action. **Isolate the boiler electrically and report the fault to Hoval Service.**

Standard Ignition (Manual)

From a 'Boiler Out' cold condition it is relatively easy to bring the boiler on-line within a few minutes by the introduction of an ignition source into a primed retort.

To set in operation:

- The operator should check that all the isolator switches associated with the motors on the stoker are in the ON position and that there is power to the Stoker Control Panel (ON/OFF to ON).
- On the Stoker control set the Wood Burner ID FAN ONLY/OFF/AUTO switch to AUTO.
- After a short delay (when both ID and FD fans operate) the pellet feed augers will begin to feed pellets into the retort.
- Run the Stoker until the retort fills with fuel - the pellets should be level or just below the last set of Turkeys (or airways within the retort). It may be necessary to open the boiler door to check the level of fuel in the retort.
- Set Wood Burner ID FAN ONLY/OFF/AUTO switch to OFF.
- Using the isolator switches on the motors, switch OFF both the PICK-UP and CONVEYOR (OR DELIVERY) augers.
- Open Boiler door.
- Add two small firelighters to the top of the retort and surround with some of the wood pellet fuel. Carefully ignite the firelighters.

- Close the Boiler Door
- Set the Wood Burner selector switch ID FAN ONLY/OFF/AUTO to the AUTO position. This will operate the stoker without adding any further fuel into the retort and will also allow combustion to establish, as both the ID fan and then the FD fan start.
- After approx 10 minutes operation check the condition of the fire within the retort to ensure that combustion is fully established (using the sight glass on the front of the door of the boiler).
- IMPORTANT. Once the fire has established the isolating switches on both the PICK-UP and the CONVEYOR augers must be switched back to ON. This allows the resumption of fuel feed into the boiler.
- Leave Stoker operating in AUTO mode.

Ignition from 'Boiler Stand-By' or Kindle

In normal operation once ignition has taken place from cold (as described above) the boiler would normally be held in 'Stand-By' or kindle mode whenever there was no call for heat (e.g. overnight or over a weekend period or up to temperature).

Combustion of the wood pellet fuel is brought to a virtual standstill and a small permanent ignition source is held within the retort. When the stoker control receives a demand signal to fire the pre-purge process with both the FD and ID fans in operation re-initiates full combustion within a few minutes. The stoker control then responds to suit the load.

Once ignition has been established the boilers can be held in Kindle (or stand-by mode) for up to 72 hours without the need to re-light the boilers. The boiler might run normally during a day, switch to kindle at the end of the day and kindle overnight (or over a weekend). The following day(s) normal operation could resume without any need for manual intervention

If it is anticipated that the available heating load would lead to any boiler kindling in excess of this period then it should be switched off.

Always ensure there is sufficient wood pellet fuel covering the pick-up auger or available at the outlet of the pellet storage silo.

Boiler Shut Down (temporary)

During Normal operation it is possible to temporarily interrupt the feeding of fuel into the boiler. This is necessary whenever the Boiler door is to be opened to access the combustion chamber. E.G. To check and inspect the fire or to remove any ash from around the retort within the Boiler.

With the boiler operating, to temporarily stop the boiler from firing fresh fuel;

- On the Stoker Control Panel, set the ID FAN ONLY/OFF/AUTO switch from AUTO to ID FAN ONLY.
- This halts the feeding of fuel into the boiler, and switches off the FD fan.
- The Boiler door can then be opened, by using the Tommy bar to loosen the nuts fastening the door shut. **CAUTION** the operator MUST stand behind the boiler door as the nuts are unloosened and the door is gradually opened. NEVER stand adjacent to the opening door.

Always ensure there is sufficient wood pellet fuel covering pick-up auger or available at the outlet of the pellet storage silo.

Operating Instructions

- Once the door has opened it should be possible to stand in front of the combustion chamber and inspect the fire, boiler surfaces etc. Note the ID fan will continue to operate and should draw any products of combustion or fumes through the boiler and into the flue and chimney but a small fire should still be visible within the retort. This will very gradually subside but the burning fuel will remain hot for many hours.
- To restart the boiler, the door should be closed and using the wood burner control on the stoker control panel, set the Wood burner selector switch from ID FAN ONLY back to AUTO. It should be possible to restart the boiler in this fashion even if it has been off for a prolonged period (2-3 hours). If enabled the stoker control will restart by initially running the ID and FD fans before allowing pellet feed at the low fire rate. The Stoker is held in low fire for a fixed period to allow the fire bed to re establish.

Note: A timer is provided in the control to limit the length of time that the ID Fan is allowed to run (when the wood burner selector switch is in the "ID FAN ONLY" setting). This will be preset to two hours.

To Switch Off the Boiler Completely

If the Boiler is to be brought off line and the fire allowed to go out, it is necessary for the operator to:

- With the stoker enabled and operating, set the BURNOUT/NORMAL selector switch to the "Burnout" position. This will run the conveyor auger tube out of pellets.
- After 15-20 minutes, turn the wood burner ID FAN ONLY/OFF/AUTO selector switch to the "off" position.
- This will allow the fire to gradually burn itself out.

De-Ashing Procedure

The STU is designed to burn a wood pellet fuel for which the ash (or non combustible mineral matter) content is carefully controlled. It is typically less than 1% by weight although this can vary depending on the pellet source. Accordingly the amount of ash to be removed from the boiler is relatively small, but depends on the load placed upon the boiler. The generously sized combustion chamber and area around the retort means that even during periods of heavy boiler loading ash removal can be as little as once per week or possibly longer. Experience will dictate most suitable de-ash frequency.

The De-Ash Process is relatively straight forward and takes a few minutes to complete:

- The stoker should be turned to "ID FAN ONLY" via the ID FAN ONLY/OFF/AUTO selector switch, (to pull any residual fumes out of the boiler).
- On the 600 - 1000kW boilers the boiler needs to be left to stand for 30 minutes

- The boiler door can then be opened using the tommy bar provided and ash/clinker removed with the rake supplied with the equipment.
- Care needs to be taken not to disturb the fuel within the retort and only the ash, not unburnt fuel, is taken from around the retort edge.
- Also clean out the hole for the combustion chamber pressure switch sensing point which is located on the LHS of the combustion chamber adjacent to the boiler door.
- Having cleared all the ash from the boiler, the door needs to be closed **and the selector switch set back to the auto position.**
- The De-Ashing process does not unduly affect the performance of the boiler but can be timed to coincide with a light load period if this is a concern.
- Where fitted, cyclone bins or the trays beneath Ceramic Filters should be checked and emptied as appropriate. A suitable vacuum cleaner should be used for this task.

The operator should wear appropriate PPE safety equipment.

Boiler Surface Cleaning

The STU has a bank of horizontal smoke tubes, through which heat transfer takes place. To ensure optimum boiler efficiency these tubes should be cleaned of any dust or debris that might settle. The flue ways or smoke tubes within the boiler should be inspected weekly and cleaned as required and this will depend on the boiler load - during a typical heating season brushing the flues once every 3-4 weeks will suffice. This is a typical figure and again experience will dictate depending on the boiler operation and loading.

Again this is a relatively straight forward process:

- The boiler to be cleaned should be turned off to "ID Fan only" via ID FAN ONLY/OFF/AUTO selector switch and allowed to cool for at least 1 - 2 hours.
- The operator should wear the appropriate PPE safety equipment, open the door of the boiler and carefully remove the spiral retarders from each of the smoke tubes.
- Each tube should then be brushed - with the tool provided - and any debris removed. Dust may collect in the rear smoke box that can be accessed from the rear of the boiler.
- The spiral retarders should be re-fitted to each tube. Any dust or clinker should be cleaned from around the retort - and the tuyeres of the retort checked so they are clear of any ash/clinker. Also clean out the small hole for the combustion chamber pressure switch sensing point which is found on the LHS of the combustion chamber adjacent to the boiler door.
- **Close the boiler door and set the selector switch back to the AUTO position.**
- The operator should check that the pellets are burning level with the top of the retort before leaving the plant to run.

The operator should again wear appropriate PPE safety equipment.

Please see Appendix D for step by step operating, cleaning and fault finding guidance information.

Maintenance - Inspection & Servicing

A Hoval approved service engineer will be required to carry out work other than the following: boiler cleaning, inspection of components for damage, initial start-up combustion check and the specified testing and minor fault rectification.

Always ensure the boiler and stoker are electrically isolated before carrying out inspections and repairs to the equipment.

No special equipment is required for normal boiler servicing.

Tools for cleaning the boiler heating surfaces are provided with the boiler.

The service engineers' equipment will include any necessary special tools and also a combustion efficiency test kit.

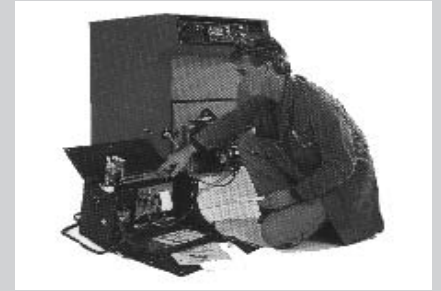

Periodic Inspection

The following periodic inspections should be made between main servicing periods.

- Examine boiler casing panels for obvious signs of damage, corrosion or other deterioration, and for security (Badly fitting casings and damaged insulation materials leads to wasted heat and an increase in the boilerhouse ambient temperature).
- Examine the flue pipe and gasket for obvious signs of damage, corrosion, flue-gas leakage, and for security. Similarly inspect the cleaning explosion door at rear of boiler.
- Examine the flue and chimney, as far as possible, for partial blockage, debris, etc.
- Ensure that condensation drains at the chimney base are clear and that the boiler flue box drain socket is connected to a drain pipe with a water trap.
- Keep the boilerhouse floor clear of dust and debris which may be drawn into the stoker and cause damage.
- Examine all fuel and water valves, connection and stoker etc, for obvious signs of damage or leakage, and for security.

In an open-vented heating system, check:

- Level of water in the feed and expansion tank.
- That the ball valve is free to operate correctly.
- All air vents are operating correctly.

NOTE: No continuous make-up of water should be taking place (In this event check where a leak may be occurring or if pumping over is taking place).

Report any occurrences which indicate that the boiler, the firing equipment or the system controls are not operating correctly.

Maintenance - Boiler and Stoker Servicing

In addition to the periodic inspections given above it is recommended that a complete check is carried out on all components at appropriate intervals.

These checks must be made by a Hoval approved service engineer, ideally under an annual service and maintenance contract.

Hoval Service Department normally provides this service and will be pleased to provide a written quotation on request. This would typically cover the operation, cleanliness, combustion efficiency etc., of the stoker and associated controls.

Boiler Heating Surfaces

- Check conditions of smokebox cleaning door gasket. Refit door, ensuring it seats correctly on the gasket and tighten the securing bar nuts.
- Check condition of boiler door ceramic seal. Inspect the lining material on the door. Minor damage to insulating material can be carefully rectified using a mouldable refractory (e.g. Pyruma) on refractory lined doors. Where a door is lined with ceramic fibre it is unlikely to suffer damage in normal use but in the unlikely event please consult Hoval. Any serious damage must be reported to the Service Engineer for repair. Filler material can be repaired similarly. The door sealing strip must be in good condition and must be replaced when an effective seal cannot be obtained under normal pressure. Replace sealing strip annually.
- Close the boiler door, and evenly tighten the nuts using a tommy bar/spanner.
- All door nuts and hinge assembly to be greased periodically.

Summer Shut Down

If the boiler is to be out of operation for a long period, e.g. during the summer, the boiler should be thoroughly cleaned.

Atmospheric condensation, activating acidic deposits in the boiler is responsible for considerable corrosion and metal wastage. Every effort should be made to reduce this by the most thorough cleaning and by keeping the boiler fireside internals dry.

A tray of absorbing material is placed in the combustion chamber is helpful in this respect. Close the boiler door.

Maintenance - Inspection & Servicing

Pick-Up Auger (Bunker Worm)

Covering/Changing rigid pick-up slots - Where fitted

The pick-up auger and tube also incorporates the flange type mounting for the worm drive motor and integral shear cover. The tube is bracketed in the bunker and sleeved into a swing tube. This allows the tube to be turned, enabling the pick up slot to be closed off and the tube to be run empty - or an alternate pick-up slot selected.

To do this, release the retaining clip and turn the tube using the turning bar provided. There are 2 grease nipples fitted to the pick-up tube and bearing (see drawing). One is fitted on the side of the Swing Tube; this should be greased periodically to aid turning the pick-up tube. The other can be found on the pick-up bearing housing next to the Shear Pin Assembly; this should be greased on a regular basis in order to prevent dust passing through the bearing into the boilerhouse (Grease Gun supplied). To spread the grease evenly throughout the bearing, pump grease in while the motor is running.

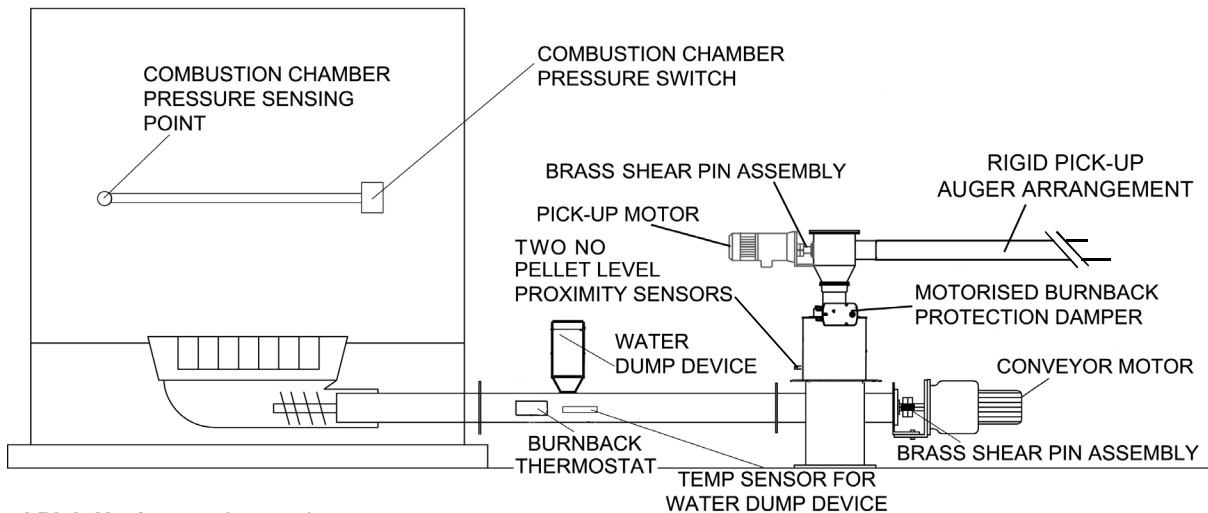

Delivery and Pick-Up Augers (worms)

Both worms are fitted with shear pin couplings, this connects the worm to the drive motor via a Brass Shear Pin. In the event of a jam, the brass pin will break and allow the motor to carry on turning undamaged.

To repair a broken shear pin drive the motor so that the shear pin slot is at the top, using the shear pin bar provided, align the slot on the worm section, remove broken pin and fit replacement. If there is a jam or pin failure on the Pick-Up Auger always check the Delivery Auger and the condition of the shear pin in the Delivery Auger - it may well have broken first and caused the Pick-Up pin to shear.

N.B. If you are unable to turn the worm section or the replaced pin breaks straight away, **contact Hoval Service**.

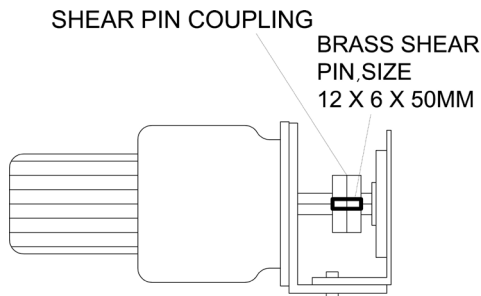

In addition to the shear pin protection all drive motors are protected via thermal overload relays in the control panel; this gives the added protection in the event of a gradual worm jam. If a motor has tripped its thermal overload a warning light will be illuminated on the front of the panel.

Forced Draught (FD) Fan

This fan is floor mounted next to the stoker and supplies combustion air to the stoker. There are two dampers on the air inlet, one has a modulating motor fitted to it and the other has a manual adjustment on it. There are set at the same time as commissioning and should only be adjusted by a suitably qualified engineer.

Induced Draught (ID) Fan

This fan is fitted at the rear of the boiler between the smoke box and the chimney. There is also a fully modulating motorised damper fitted in the duct work between the boiler and the ID fan. The motorised damper is controlled by a preset pressure switch keeping a negative pressure over the fire. The drive from the motor to the fan is via 2x fan belts, these require checking during servicing and changing if necessary.

Appendix A

GRP SILO SPECIFICATION SHEET

Ø2.85m

Silo Specifications

- Single piece cone & body.
- No seams, joints or bolted sections.
- Corrosion resistant for long life.
- UV Stabalised GRP Material to protect contents and silo.
- Semi-transparent GRP Allowing contents level to be checked.
- Smooth interior for constant flow of feed.
- 60° Cone angle.
- Superior thermal insulation values compared with steel silo.
- All steel work hot dipped galvanized.
- 101.6mm diameter fill pipe c/w long radius bends allowing smooth easy filling of silo with minimum product damage.
- 160mm ventilation pipe maintains internal ambient temperature.
- Inspection hatch optional.
- Position of fill pipe & vent pipe are standard as per diagram.
- 400mm diameter outlet.



SILO VOLUME (m ³)	A HEIGHT (m)	B INTERNAL DIAMETER (m)	C INSIDE LEG (m)	D DISCHARGE HEIGHT (m)	CAPACITY		MINIMUM CONCRETE BASE SIZE (m)
					TONNES (560Kg/m ³)	TONNES (693Kg/m ³)	
15	5.46	2.85	1.985	0.80	8.40	10.40	4.0 x 4.0 x 0.3
20	6.25				11.20	13.90	
25	7.05				14.00	17.30	
30	7.80				16.80	20.80	
35	8.60				19.60	24.25	
40	9.37				22.40	27.72	
45	10.17				25.20	31.18	
50	10.97				28.00	34.65	

* All dimensions are approximate & subject to change without customer notification

Thermal safety Heat Exchange Detail

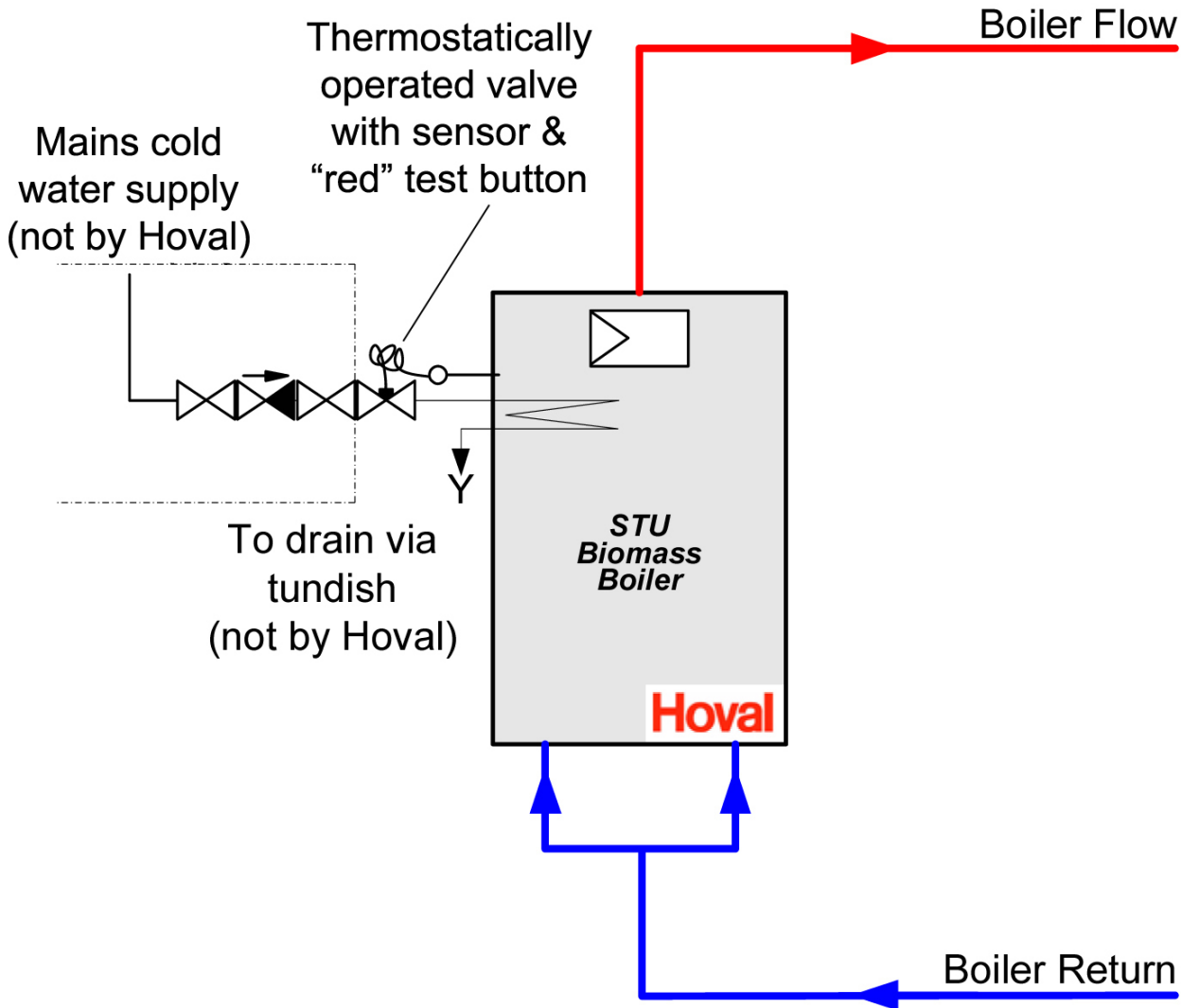

Each STU Boiler is fitted with a thermal safety heat exchange device.

Within the waterway of the boiler there are a number of small independent heat exchanger coils. If the boiler water temperature exceeds 95°C the thermostatic valve opens and allows cold mains water to pass through the coils to quickly reduce the boiler water temperature. The cooling water exit coil should be directed to drain via tundish.

Connection 3/4" Thermostatic valve.

Connection 3/4" pipework to drain.

A cold water supply with a minimum pressure of 2 bar is necessary

Note: The thermostatically operated valve has a "red" test button which will prove the valve opens when pressed & held in.

Appendix C - Boiler Familiarisation Information

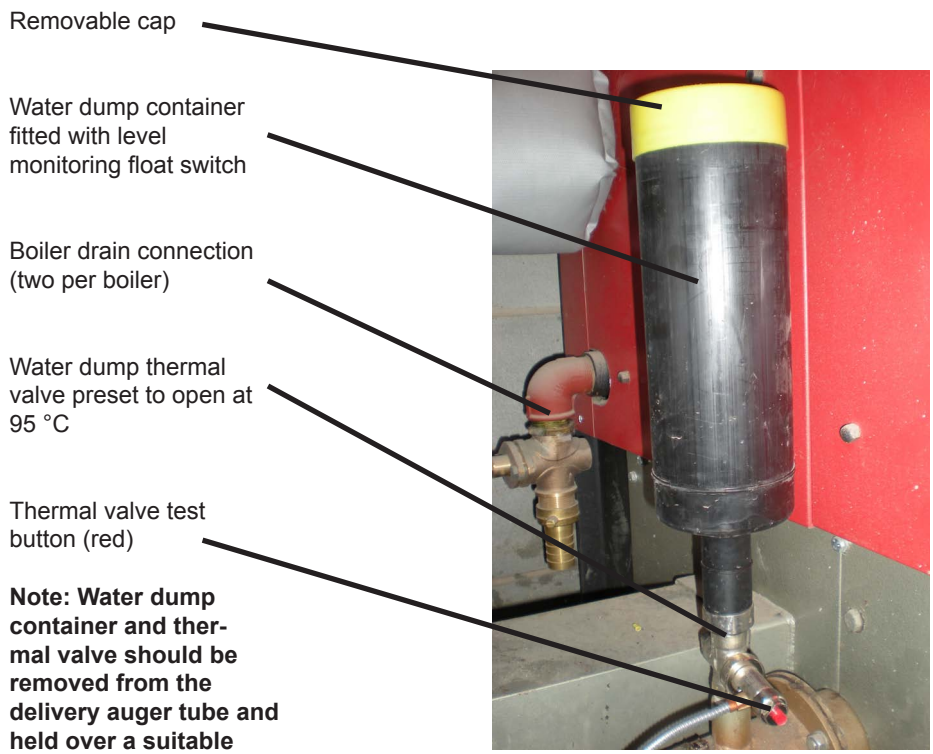

Note: Water dump container and thermal valve should be removed from the delivery auger tube and held over a suitable container before testing. Please ensure the container is refilled with water after testing.

Appendix C - Boiler Familiarisation Information

Remove cap and check the water level weekly. Water should be within 50mm of the top of the water dump container. Replace lid after checking and / or re-filling.



Level monitoring float switch (not shown in main photograph)

Manual reset burnback thermostat access cover. Isolate the boiler control panel (via the main isolator switch on the panel facia) before removing this cover.



Appendix C - Boiler Familiarisation Information

Manual reset burn-back thermostat set to 60 °C

Manual reset button (remove cover to access as shown)



Boiler Door Microswitch



Combustion Chamber Sight Glass

Appendix C - Boiler Familiarisation Information

Pellet Drop box
Two No, proximity level sensors in pellet delivery auger transfer box
Access cover to delivery auger to drive coupling shear pin



Burn-back protection damper

Stoker delivery auger to drive coupling brass shear pin.
Shear pin size 12mm x 6mm x 50mm

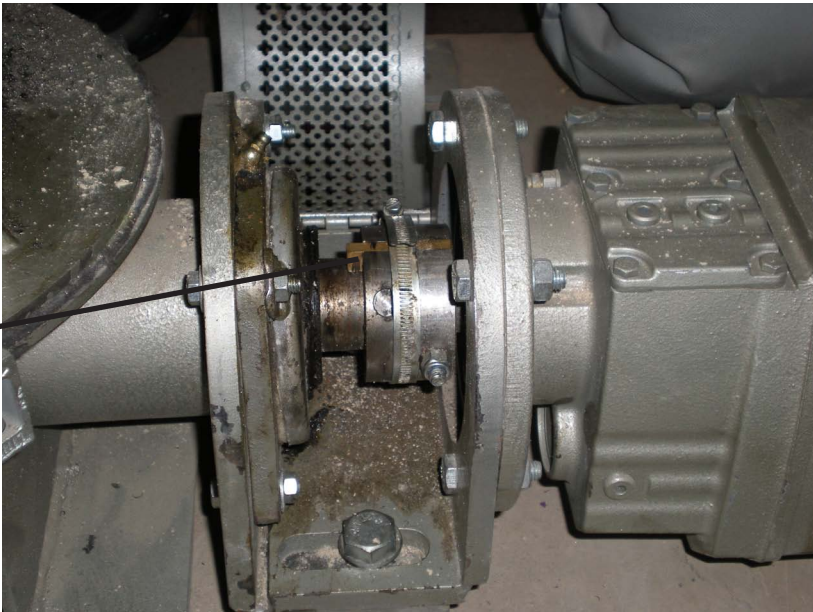

Appendix C - Boiler Familiarisation Information

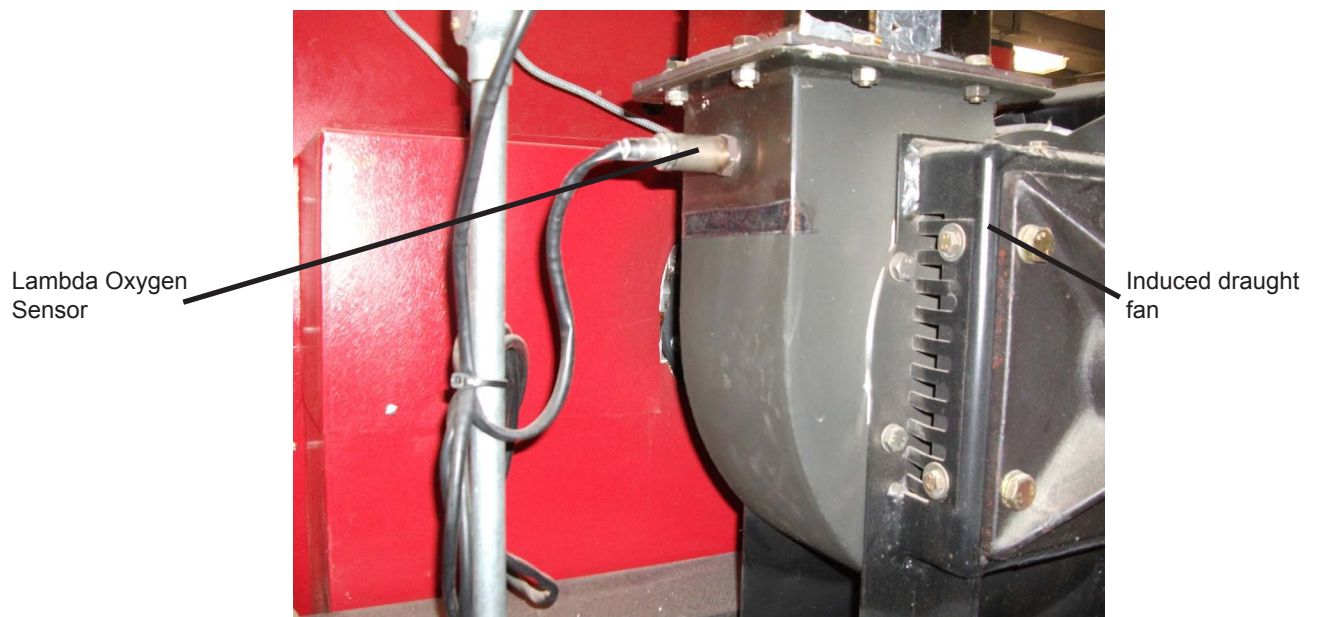
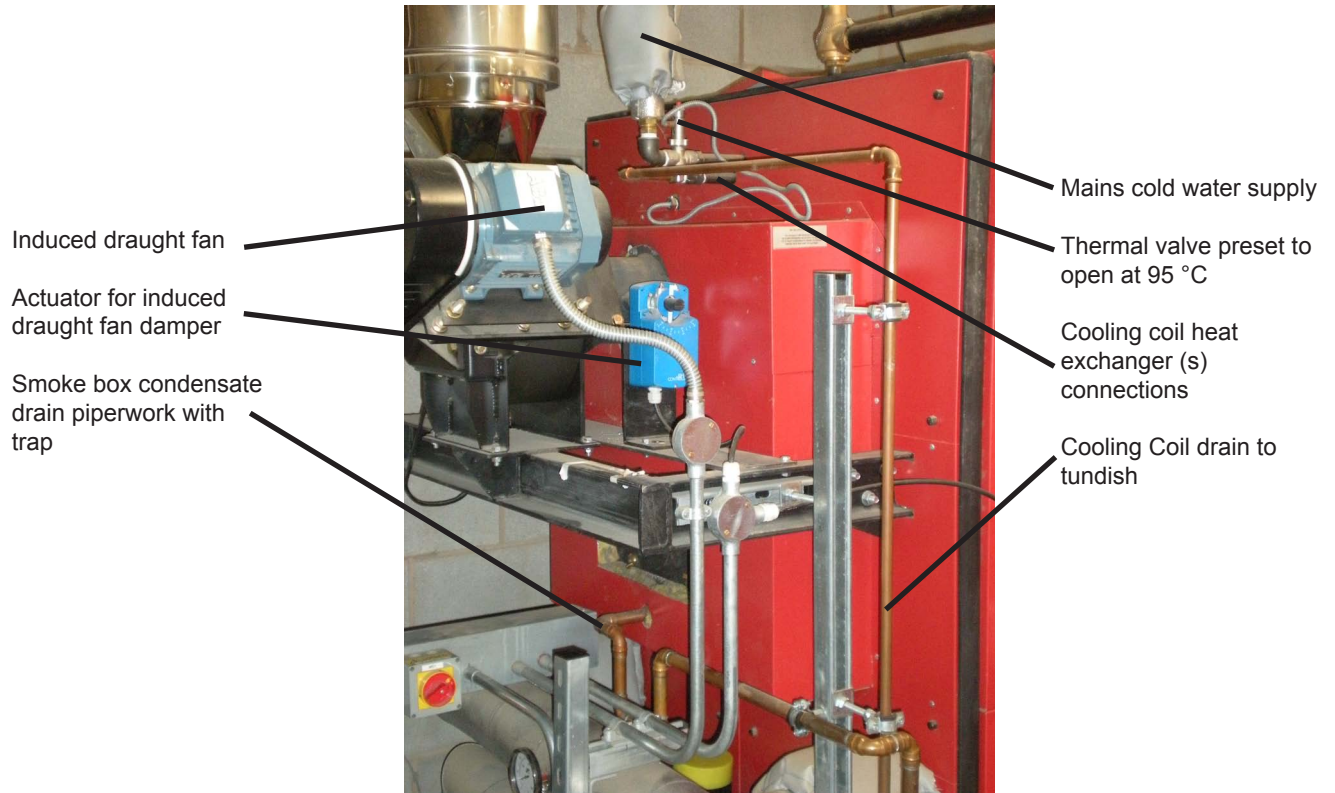

Appendix C - Boiler Familiarisation Information

Combustion chamber pressure switch

Combustion chamber pressure sensing point with interconnecting pipework to pressure switch. **Clean this out weekly**

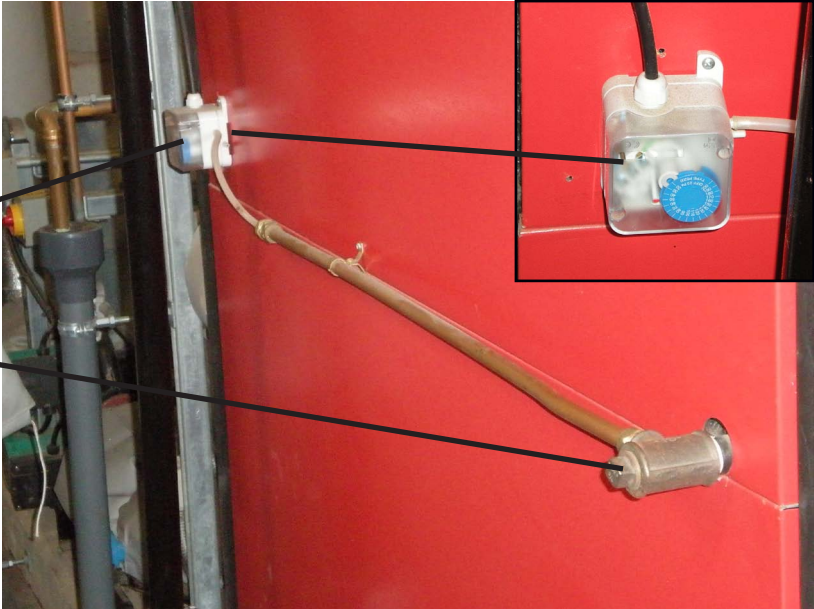

Forced draught fan with motorised damper

Forced draught air duct to retort plenum area

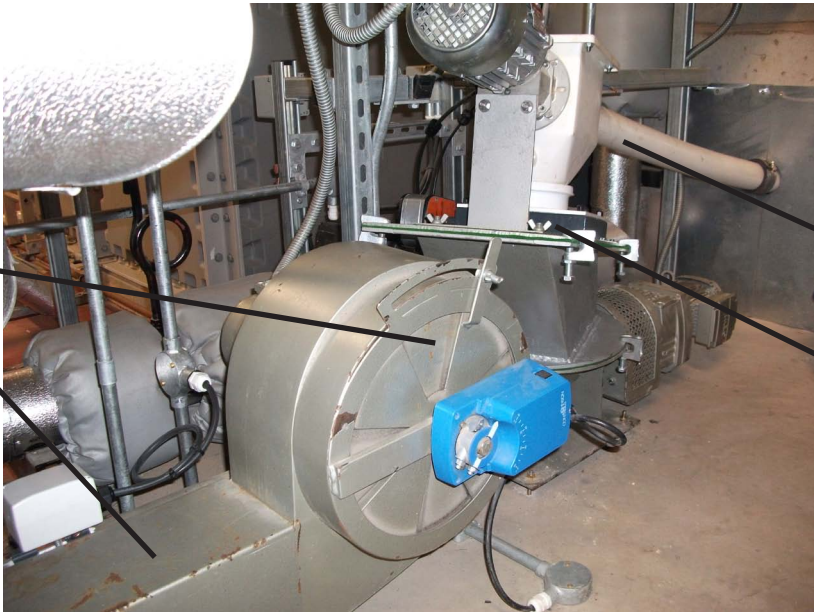

Pellet pick - up auger

Burn-back protection damper

Appendix C - Boiler Familiarisation Information

Refractory fibre boiler door lining

Cut out for sight glass opening



View of combustion chamber with pellets in the retort at the correct level for lighting



Appendix C - Boiler Familiarisation Information



Remove insulated red cover below boiler door and lift off metal inspection panel to gain access to the optional 3kW electric ignition unit (located behind this second cover). **The boiler control panel must be electrically isolated before working on the ignition unit**



Appendix C - Boiler Familiarisation Information

Optional 3kW electric ignition unit



Lift off metal inspection panel

DE-ASHING THE BOILER

Use personal protection (Gloves, Goggles and Mask)

- 1) It is necessary to clear the ash from the combustion chamber, with the Rake provided, on a regular basis. The frequency of this will depend on site's requirements for heat and the outside temperatures.
- 2) Switch the Wood burner to the "**I.D. Fan Only**" position, found on the ID FAN ONLY/OFF/AUTO selector switch mounted on the control panel.
- 3) Take care when opening the large door.
- 4) Only the fine ash should be removed, leaving the semi burnt pellets around the tuyeres inside the boiler.
- 5) Clean the small hole for the combustion chamber pressure switch sensing point, which is found on the L.H.S of the combustion chamber , close to the boiler door.
- 6) Close the door and reset the selector switch to the "**Auto**" position.

CAUTION ashes may still be hot, dispose of with care.

CLEANING THE BOILER HEATING SURFACES

Use personal protection (Gloves, Goggles and Mask)

- 1) Prior to cleaning, switch the Wood burner to the “**Off**” position via the ID FAN ONLY/OFF/AUTO selector switch mounted on the control panel
- 2) Allow the boiler to cool down (2 hours approx).
- 3) Turn the selector switch to the “**I.D. Fan only**” position.
- 4) Open the door carefully.
- 5) Carefully remove the spiral retarder from each heat exchanger tube.
- 6) Clean flues with the brush provided.
- 7) Clean the rear smoke box catchment area ensuring catchment doors are sealed when refitted.
- 8) Refit the spiral retarders.
- 9) Clean the small hole for the combustion chamber pressure switch sensing point, which is found on the L.H.S. of the combustion chamber, close to the boiler door.
- 10) Close the door.
- 11) Turn the Wood burner switch selector to “**Auto**”.

Check the condition of the flues weekly. Cleaning these flues on a regular basis will ensure good combustion efficiency; the frequency of cleaning will depend on site and weather conditions.

TURNING THE BOILER OFF

- 1) With the Wood burner running switch the BURNOUT/NORMAL selector switch to the “**Burnout**” position This will run the conveyor tube out of fuel.
- 2) After 15-20 minutes, turn the Wood burner I.D. FAN ONLY/OFF/AUTO selector switch to the “**Off**” position.
- 3) The fire can now be allowed to burn itself out.

TO LIGHT THE BOILER With Ignition (where fitted)

Important: Before using the Electric Ignition system open the Boiler door and CHECK that the Stoker Retort(s) are clear of pellets before initiating the Ignition system

- 1) Switch the control panel AUTO/ IGNITION selector switch to the "**Ignition**" position.
- 2) Switch the Wood burner I.D. FAN ONLY/OFF/AUTO selector switch to "**Auto**" at the panel and allow the machine to run. (The ignition will have three attempts to light)
- 3) When the fire is established switch the AUTO / IGNITION selector switch to the "**Auto**" position and the boiler will operate as normal.
- 4) **Important: If the boiler fails to light on its third attempt do not reset the switch and attempt to fire again. Switch the wood burner I.D. FAN ONLY/OFF/AUTO selector switch to the "Off" position and report the fault.**

TO LIGHT THE BOILER Manually

- 1) Open the door.
- 2) Switch the Wood burner I.D. FAN ONLY/OFF/AUTO selector switch to "**Auto**" and allow the machine to run until the pellets are level with the top of the retort tuyeres in the boiler.
The start-up sequence is: I.D. Fan start - 2min delay -
F.D. Fan start - 4min delay - pellet feed start.
- 3) Turn the Wood burner selector switch to the "**Off**" position when the pellets are level with the top of the retort tuyeres.
- 4) Light the fire using fire lighters or paper and cardboard and close the door.
- 5) Switch the wood burner I.D. FAN ONLY/OFF/AUTO selector switch back to "**Auto**" and ensure the "**Pick-up** and **Conveyor**" augers are turned off at the isolators.
- 6) Allow 10-15 mins. for the fire to get established and then turn the local isolators back on.
- 8) If the fire is not established allow more time before turning the "**Pick-up** and **Conveyor**" augers back on.

NOTE: For a boiler fitted with an optional ignition system, the above procedure should only be employed in the event that the ignition system fails to work.



Appendix - D Operating, Cleaning and Fault - Finding Procedures

In The Event of a Fault Condition/ Power Interruption

- 1) In the event of a fault condition turn the I.D. FAN ONLY/OFF/AUTO selector switch on the wood burner control panel to the “**Off**” position. This will remove the call for the boiler to run, but will keep the safety devices on the boiler active.
- 2) Do **NOT** turn the motor isolators off; this will render the safety devices inactive.
- 3) Do **NOT** attempt to run the boiler again until a Suitably Qualified Engineer has investigated and rectified the fault.

The following Items will cause a Fault Condition and will record a message on the LRP unit.

FAULT	CAUSE
First High Limit:	Boiler water temperature has reached 85°C due to circulation/heat dissipation Problems resulting in boiler creep.
Second High Limit (Manual reset):	Boiler water temperature has reached 95°C due to Circulation Pump Failure or a power interruption.
Manual reset burn-back Thermostat initiation:	Fire has tracked back along the conveyor tube. Possible causes are: Conveyor motor tripped (see below) or shear pin failure, burn back thermostat malfunction or a prolonged power interuption. This can also be caused by leaving the ID fan running continuously on the ID FAN ONLY/ OFF/AUTO selector switch.
Boiler door micro-switch or burn-back protection damper fault:	A fault has occured with either of these items, which will cause the stoker to trip and display a fault message.
Motor Trip:	One or more thermal over loads have tripped preventing the motor(s) from running.
Oxygen High:	Fire has gone out in the retort.
Oxygen Low:	Products of combustion are not being removed from boiler.
Incoming Phase Fault:	Phases on incoming power supply stoker control panel have been changed up stream of panel.
Ignition system (where fitted) fails to light the fire bed:	Fault with hot air ignition unit. Alternatively, if the boiler flue gas temperature is greater than 50°C, the system will not operate the ignition unit.
Low water level alarm:	Low water level switch has been activated in the water dump container.

Notes: Please refer to the Boiler Operating Manual for further information on the above.

In addition the thermostatic valves on the boiler cooling coil and water dump devices may have been activated depending on the type of fault or if a power interruption has occurred.



Notes.



Notes.

Hoval Ltd

Northgate

Newark

Notts

NG24 1JN

Tel No's: (01636) 59413 or 593435 (Service Desk direct dial numbers)
(01636) 593412 (Spares Desk direct dial)

Fax: (01636) 673532

e-mail: service@hoval.co.uk
spares@hoval.co.uk

Hoval

STUman June 2010 (WA)