

Hoval

Installation, Operation and Maintenance Instructions



PowerBloc EG (43-404) combined heat and power plant.

Contents

1.	An Introduction to Hoval Combined Heat and Power	
1.1.	Foreword.....	4
1.2.	Introduction.....	4
2.	Safety Information	
2.1.	Safety Information Introduction.....	5
2.2.	Specific Warnings.....	5
3.	Important Notes	
3.1.	Acceptance of Delivery.....	7
3.2.	Scope of Guarantee.....	7
3.3.	Instruction Manuals.....	7
3.4.	Standards.....	7
4.	Technical Data	
4.1.	PowerBloc EG (43-140) Technical Data.....	8
4.2.	PowerBloc EG (200-404) Technical Data.....	9
4.3.	PowerBloc EG (43-70) Dimensions.....	10
4.4.	PowerBloc EG (104-140) Dimensions.....	11
4.5.	PowerBloc EG (200-404) Dimensions.....	12
5.	Installation Requirements	
5.1.	Site Requirements.....	13
5.2.	Additional Notes for the Installer.....	13
5.3.	Readiness for Operation.....	13
5.4.	Further Important Information.....	14
5.5.	Waste Disposal.....	14
6.	Water Quality	
6.1.	Heating Water.....	15
7.	Typical Pipework Schematics	
7.1.	CHP in Parallel.....	16
7.2.	CHP in Series.....	16
8.	Construction	
8.1.	Construction of The CHP Plant.....	17
8.2.	The Gas Engine.....	17
8.3.	The Generator.....	17
8.4.	Engine Cooling Water Heat Exchanger.....	18
8.5.	Exhaust Gas Heat Exchanger.....	18
8.6.	Engine Cooling Circuit.....	18
8.7.	Heating Water Circuit.....	18
8.8.	Exhaust Catalytic Converter.....	18
8.9.	Ventilation.....	18
8.10.	Monitoring devices.....	18
9.	Functional Description	
9.1.	Functional Description of The CHP Plant.....	19

10. Control Panel Overview	
10.1. Control Panel.....	20
10.2. Overview of Functionality.....	21
10.3. Manual and Automatic Operation.....	21
10.4. Safety System.....	22
10.5. Grid Monitoring.....	22
10.6. Generator Monitoring.....	22
10.7. Engine Control.....	22
10.8. Speed Control.....	22
10.9. Power Output Control.....	22
10.10. Lambda Control.....	22
10.11. Touch Screen Display.....	22
11. Controls Overview.....	23
12. Pre-Commisioning	
12.1. Engine.....	30
12.2. Oil Supply.....	30
12.3. Gas Supply.....	30
12.4. Heating Water System.....	30
12.5. Electrical Connection.....	30
13. Maintenance And Servicing	
13.1. Overview.....	31
13.2. Oil Change.....	31
13.3. Spark Plugs.....	31
13.4. Air Filter.....	32
13.5. Valve Clearance.....	32
13.6. Starter Battery.....	32
13.7. Engine Coolant Pressure.....	32
13.8. Generator.....	32
13.9. Post service.....	32
14. Customer Service	
14.1. Contacting Hoval.....	33
14.2. Remote Servicing.....	33
15. Fault Finding	
15.1. Alarms.....	34
15.2. Fault Codes.....	35
15.3. Gas Leaks.....	35
15.4. Oil Leaks.....	35
15.5. Heating Circuit Leaks.....	35
15.6. Exhaust Gas Leaks.....	35

1. An Introduction to Hoval Combined Heat and Power

1.1. Foreword

These instructions have been written to give a brief description of the PowerBloc EG (43-404) combined heat and power plant (CHP plant), their installation, commissioning, operation and subsequent preventative maintenance.

The installation of CHP plant and their ancillary equipment is normally carried out by a competent Engineer, and for the purpose of this manual they are regarded as the installer, and, as such, it is their responsibility to ensure that they have read and understood the contents of this manual before installing and operating the CHP plant. As the manufacturer, Hoval cannot accept any responsibility for any damage, faults or injuries caused by non compliance with this published document.

A copy of this manual must be available on site at all times as the operating personnel will need to be able to reference it as quickly as possible. It is imperative that this manual has been read and understood before operating the CHP plant.

Hoval, or Hoval approved Engineers will commission the CHP plant. It is essential that the installer and the operator of the CHP plant are present at the commissioning handover as they can then be instructed on the day-to-day use and operation of the CHP plant. If this is not possible, or additional training is required, a further site visit can be arranged through Hoval.

Hoval retains the copyright to this documentation. The drawings, images or information may not be reproduced or distributed, in their entirety or as extracts, or passed to others, without written consent of Hoval Ltd.

1.2. Introduction

A Hoval combined heat and power plant consists of a gas fuelled internal combustion engine coupled to a three-phase synchronous generator. With the CHP plant it is designed that both the electricity and heat generated are utilised resulting in high efficiencies, much more efficient than a typical fossil fuel power station.

Hoval CHP plant is generally supplied skid mounted and housed within a sound reduction capsule for installation into a suitable building plant room. Alternatively the CHP plant can be supplied within a complete packaged plant room for external siting.

The CHP plant has highly sophisticated controls as it is responsible for the fully automatic operation of the plant. In addition to controlling the engine and monitoring all of its values, the controls are also responsible for the synchronisation of the generator to the grid and the dissipation of heat from the engine to the connected heating circuit. The emissions from the exhaust system are measured and tightly controlled to their set values. If necessary the Hoval CHP plant can be equipped to be back-up power generation should the electrical power from the mains fail. Should this be required, Hoval Technical should be contacted for assistance.

The controls from the CHP plant are from Noris Automation GmbH which are all interfaced from one central hub that can be interrogated by the touch-screen interface. Many different external interfaces can be configured, however these need to be confirmed at time of order as they may result in hardware changes. These interfaces can be either read from a master controls system or over other media such as the internet. Remote control such as the internet interface can be used to quickly rectify faults caused by changing operating conditions.

2. Safety Information

2.1. Safety Information Introduction

The CHP plant is manufactured to a very high level to ensure that it complies with all safety requirements and regulations. However, due to the nature of the equipment dangers are present and these may pose a risk if it is operated improperly or by untrained personnel.

The operator on site is responsible to ensure that only trained and authorised personnel can enter, operate and maintain the CHP plant.

Safety must never be compromised when operating or maintaining the CHP plant.

The operator on site should inspect the plant on a daily basis for any signs of damage or defects and report them immediately.

Any unauthorised modifications are prohibited as this may affect safety and correct functionality of the plant.

Before work commences for example on a preventative maintenance or break-down visit the controls must be locked off against an inadvertent start-up.

A permit-to-work system should be put in place by the operator prior to all such work being undertaken.

The exhaust system must be sealed and not have any leaks. If a gas escape is detected the CHP plant must be switched off immediately and an appropriate specialist investigate the issue.

Used oil and coolant must be disposed of in accordance to the local regulations.

2.2. Specific Warnings



Danger of death / explosion due to a potentially explosive atmosphere in the confinements of the CHP plant, as a result of a gas leakage.

If you detect an acrid smell in the confinements of the CHP plant, combustible gas has escaped into the air surrounding the CHP plant.

- No naked flames!
- Prevent Sparking! Do not operate any electrical devices such as switches or telephones.
- If the gas escape can be heard, leave the area immediately!
- If possible and it is safe to do so close the isolation valve.
- Open all external windows and doors!
- Warn any other persons in the danger zone and instruct them to leave!
- Prevent others from entering the danger zone!
- Call the fire service from a position away from the danger zone!
- Contact National Grid Gas Emergencies on 0800 111 999.

Note: all gas work must be performed by qualified and competent personnel.



Danger of death / fire as a result of a gas leakage or present combustible materials / liquids.

- No naked flames!
- If possible and it is safe to do so, close the main gas isolation valve.
- Do not enter any confined spaces!
- Alert any persons in the danger zone and instruct them to leave!
- Call the emergency services from a safe location!
- Do not attempt to put out the fire yourself unless you are confident in doing so AND you are not putting yourself at any risk.
- A fire extinguisher should be available in the plant room where the CHP plant is installed
- A dry powder fire extinguisher must be in-date and to current standards.



Danger of death as a result of asphyxiation.

An insufficient air supply can lead to dangerous escapes of exhaust gases.

- If the ventilation is insufficient isolate the CHP plant and take it out of operation.
- Ensure all ventilation openings are unrestricted and free of any blockages.



Danger of death as a result of electric shocks.

Caution, even if the mains switch is isolated on the panel, labelled components within the control panel may still be live. High voltages are present in the electrical equipment and cables on the CHP plant. Touching any of the live components could lead to fatal injury!

- The CHP plant must always be de-energised before commencing work. Protective covers must only be removed once bare contacts are de-energised.
- Never touch exposed or bare cables / contacts.
- All electrical work on the CHP plant must be performed by a Qualified Electrician.
- Only open the control cabinet when necessary.



Danger of serious injury through crushing or severing of body parts.

Depending on which mode of control the CHP plant is in, it may start-up inadvertently without any prior warning.

- Never reach into the inside of the CHP plant whilst it is running.
- Before working on the plant always ensure that it is switched into the off position.
- Only remove protective covers when necessary. Always replace the protective covers as soon as is practical to do so.



Danger of injury / hand injuries as a result of sharp edges.

- Always wear protective gloves when working on the CHP plant.
- Due to a danger of acid burns, suitable protection must be worn when working on the batteries.



Danger of injury / burns caused by very hot components, operating materials and heating water.

The CHP plant reaches very high temperatures. Even after being turned off and left to cool some components may still be hot (for example the turbocharger can run at 700°C).

- Never touch any components of the CHP plant whilst it is in operation or shortly after operation unless you are sure it is safe to do so.
- Check the temperature of specific components before touching them or performing work on the CHP plant.

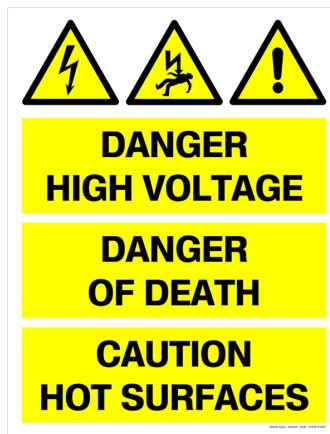

3. Important Notes

3.1. Acceptance of Delivery

A visual inspection upon delivery should be performed including a check to ensure all components are present. In the event of there being damage or missing parts, the necessary steps should be followed as specified in the delivery contract.

The cost for correcting the damage shall be taken over by the individual risk bearer.

3.2. Scope of Guarantee

The guarantee does not cover defects caused by:

- Non-observance of these instructions
- Non-observance of the MAN instructions
- Incorrect installation
- Unauthorised modifications
- Improper use
- Contaminated operating media (gas, water, combustion air)
- Unsuitable chemical additives in the water circuits
- Damage due to excessive force
- Corrosion due to halogen compounds
- Corrosion due to nonconforming water quality

3.3. Instruction Manuals

As well as this document please refer to the specific MAN engine and Marelli / Stamford Generator manuals. A copy of all documentation should be kept with the CHP plant.

Additional sources of information:

- Hoval catalogue
- Standards and regulations

3.4. Standards

When installing, operating and maintaining the CHP plant you must comply with all country-specific laws, standards and directives.

The installation must be in accordance with current I.E.E. Regulations, relevant British & European standards and Codes of Practice, Building Regulations and Local Authority ByLaws.

4. Technical Data

4.1. PowerBloc EG (43-140) Technical Data

PowerBloc		EG-43	EG-50	EG-63	EG-70	EG-104	EG-140
Electrical output	kW	22 - 43	25 - 50	31 - 63	35 - 70	52 - 104	70 - 140
Thermal output	kW	40 - 65	53 - 81	58 - 95	67 - 114	77 - 142	130 - 207
Fuel input	kW	78 - 129	92 - 145	99 - 177	122 - 204	151 - 282	225 - 384
Electrical efficiency	100%	%	33.3	34.5	35.6	34.3	36.9
	75%	%	30.8	31.1	34.5	33.3	35.9
	50%	%	28.2	27.2	31.3	28.7	34.4
Thermal efficiency	100%	%	50.4	55.8	53.7	55.9	50.3
	75%	%	51.0	56.3	54.7	55.3	50.2
	50%	%	51.3	57.6	58.6	54.9	51.0
Total efficiency	100%	%	83.7	90.3	89.3	90.2	87.2
	75%	%	81.8	87.4	89.2	88.6	86.1
	50%	%	79.5	84.8	89.9	83.6	85.4
CHP coefficient at full load		0.66	0.62	0.66	0.61	0.73	0.68
Working temperature max	°C	90	90	90	90	90	90
Return temperature min/max	°C	50 - 70	50 - 70	50 - 70	50 - 70	50 - 70	50 - 70
Volumetric heating flow	m³/h	3.1	3.5	4.1	4.9	6.1	8.9
Working pressure min/max	bar	1 - 5.4	1 - 5.4	1 - 5.4	1 - 5.4	1 - 5.4	1 - 5.4
Hydraulic resistance	mbar	50-60	50 - 60	50 - 60	50 - 60	50 - 60	50 - 60
Natural gas pressure min/max	mbar	18 - 100	18 - 100	18 - 100	18 - 100	18 - 100	18 - 100
Natural gas consumption	m³/h	12.94	14.54	17.75	20.46	28.28	38.52
Exhaust gas temperature	°C	120	120	120	120	120	120
Required exhaust back pressure	kPa	1.5	1.5	1.5	1.5	1.5	1.5
Exhaust gas flow - wet	kg/h	159	192	361	272	594	503
Exhaust gas flow - dry	Nm³/h	129	156	288	221	474	409
Standard emission rate	Nitrogen Oxides	mg/Nm³	<125	<125	<500	<250	<500
	Carbon monoxides	mg/Nm³	<150	<150	<300	<300	<300
Supply air temperature	°C	10 - 30	10 - 30	10 - 30	10 - 30	10 - 30	10 - 30
Supply air flow	m³/h	2500	3000	3140	4000	4200	5300
Combustion air	m³/h	125	151	290	214	478	396
Extract air temperature max	°C	50	50	50	50	50	50
Extract air flow	m³/h	2375	2849	2850	3786	3722	4904
Radiation heat max	kW	12	15	15	20	19	25
Dimensions							
Weight	Dry	kg	2000	2000	2100	2200	3100
	Flooded	kg	2200	2200	2300	2400	3300
Acoustic level at 1m ⁽¹⁾		dB(A)	62	62	70	70	70
Exhaust gas acoustic level at 10m		dB(A)	60	60	70	70	70
As above with optional secondary silencer		dB(A)	40	40	50	50	50
Engine							
Manufacturer		MAN	MAN	MAN	MAN	MAN	MAN
Model		E0834 E312	E0834 E302	E0834 LE302	E0836 E302	E0836 LE202	E2876 E312
ISO standard power	kW	47	54	68	75	110	150
Normal rotation speed	r/min	1500	1500	1500	1500	1500	1500
Fuel		Natural gas	Natural gas	Natural gas	Natural gas	Natural gas	Natural gas
Cylinder		4R	4R	4R	6R	6R	6R
Swept volume	dm³	4.58	4.58	4.58	6.87	6.87	12.82
Bore	mm	108	108	108	108	108	128
Stroke	mm	125	125	125	125	125	166
Mean effective pressure	Mpa	0.821	0.943	1.19	0.873	1.281	0.936
Mean piston speed	m/s	6.3	6.3	6.3	6.3	6.3	8.3
Compression ratio		13:1	13:1	11:1	13:1	11:1	12:1
Lubricating oil consumption	kg/h	0.075	0.075	0.075	0.1	0.125	0.125
Lubricating oil volume	dm³	9/13	9/13	9/13	24/34	24/34	19/28
Weight-dry	kg	430	430	495	520	605	830
Generator							
Manufacturer		Stamford	Stamford	Marelli	Marelli	Marelli	Marelli
Model		UC.I224F23	UC.I224F23	MJB225LA4	MJB225LA4	MJB250LA4	MJB250LB4
Mode		Synchronous	Synchronous	Synchronous	Synchronous	Synchronous	Synchronous
Maximum rating	kVA	72.5	72.5	132	132	220	250
Continuous output	kVA	65	65	79	88	130	175
Rotating speed	r/min	1500	1500	1500	1500	1500	1500
Efficiency	%	93	93	93	94	94.8	93.5
Voltage	V	400	400	400	400	400	400
current	A	62	72	91	101	150	202
Frequency	Hz	50	50	50	50	50	50
Ingress protection class		IP23	IP23	IP23	IP23	IP23	IP23
Insulation system		H	H	H	H	H	H
Warming class		F	F	F	F	F	F
Weight	kg	350	350	405	405	405	710

⁽¹⁾ Noise data recorded when complete with sound reduction housing.

The above quoted data is based on Natural Gas with a calorific value of 36.0 MJ/Nm³ (10.0 kWh/Nm³) and a Methane value greater than 80
Efficiency data was obtained under standard atmospheric conditions: air pressure 100 kPa, air temperature 298°K, relative air moisture 30%

Clamp power at generator with $\cos \phi = 1.0$

Hoval follows a policy of continued improvement and reserves the right to change specifications without notice.

4.2. PowerBloc EG (200-404) Technical Data

Powerblock			EG-200/50	EG-200/80	EG-240	EG-250	EG-365	EG-404
Electrical output		kW	100 - 200	100 - 200	118 - 240	125 - 254	182 - 365	202 - 404
Thermal output		kW	161 - 269	178 - 293	220 - 365	185 - 321	280 - 496	297 - 520
Fuel input		kW	312 - 538	318 - 553	397 - 669	374 - 680	514 - 955	560 - 1045
Electrical efficiency	100%	%	37.2	36.2	35.9	37.3	38.2	38.6
	75%	%	35.2	34.3	33.4	36.5	37.5	38.0
	50%	%	32.1	31.4	29.7	33.4	35.4	36.1
Thermal efficiency	100%	%	50.0	53.0	54.5	47.2	51.9	49.8
	75%	%	50.5	54.3	55.6	47.9	52.1	51.4
	50%	%	51.6	56.0	55.4	49.5	54.5	53.0
Total efficiency	100%	%	87.2	89.2	90.4	84.5	90.1	88.4
	75%	%	85.7	88.6	89.0	84.4	89.6	89.4
	50%	%	83.7	87.4	85.1	82.9	89.9	89.1
CHP coefficient at full load			0.75	0.68	0.66	0.79	0.74	0.78
Working temperature max		°C	90	90	90	90	90	90
Return temperature min/max		°C	50 - 70	50 - 70	50 - 70	50 - 70	50 - 70	50 - 70
Volumetric heating flow		m³/h	11.6	12.6	15.7	13.8	21.3	22.4
Working pressure min/max		bar	1 - 5.4	1 - 5.4	1 - 5.4	1 - 5.4	1 - 5.4	1 - 5.4
Hydraulic resistance		mbar	50 - 60	60 - 50	50 - 60	50 - 60	50 - 60	50 - 60
Natural gas pressure min/max		mbar	18 - 100	18 - 100	18 - 100	18 - 100	18 - 100	18 - 100
Natural gas consumption		m³/h	53.96	55.48	67.1	68.2	95.79	104.81
Exhaust gas temperature		°C	120	120	120	120	120	120
Required exhaust back pressure		kPa	1.5	1.5	2	1.5	1.5	1.5
Exhaust gas flow - wet		kg/h	1101	1145	879	1392	1989	2126
Exhaust gas flow - dry		Nm³/h	878	914	713	111	1587	1698
Standard emission rate	Nitrogen Oxides	mg/Nm³	<500	<500	<250	<500	<500	<500
	Carbon monoxides	mg/Nm³	<300	<300	<300	<300	<300	<300
Supply air temperature		°C	10 - 30	10 - 30	10 - 30	10 - 30	10 - 30	10 - 30
Supply air flow		m³/h	6200	6400	7900	7220	10500	11500
Combustion air		m³/h	884	920	700	1120	1600	1700
Extract air temperature max		°C	50	50	50	50	50	50
Extract air flow		m³/h	5316	5480	7200	6100	8900	9800
Radiation heat max		kW	27	28	36	31	45	49
Dimensions			See table of dimensions					
Weight	Dry	kg	4300	4300	4300	4200	5150	5300
	Flooded	kg	4500	4500	4500	4400	5350	5500
Acoustic level at 1m ⁽¹⁾		dB(A)	70	70	70	70	70	70
Exhaust gas acoustic level at 10m		dB(A)	70	70	70	70	70	70
As above with optional secondary silencer		dB(A)	50	50	50	50	50	50
Engine								
Manufacturer			MAN	MAN	MAN	MAN	MAN	MAN
Model			E2876 LE302	E2876 LE302	E2842 E312	E2848 LE322	E2842 LE322	E2842 LE322
ISO standard power		kW	210	210	250	265	380	420
Normal rotation speed		r/min	1500	1500	1500	1500	1500	1500
Fuel			Natural gas	Natural gas	Natural gas	Natural gas	Natural gas	Natural gas
Cylinder			6R	6R	12V	8V	12V	12V
Swept volume		dm³	12.82	12.82	21.93	14.62	21.93	21.93
Bore		mm	128	128	128	128	128	128
Stroke		mm	166	166	142	142	142	142
Mean effective pressure		Mpa	1.311	1.311	0.912	1.45	1.387	1.532
Mean piston speed		m/s	8.3	8.3	7.1	7.1	7.1	7.1
Compression ratio			11:1	11:1	12.5:1	12:1	12:1	12:1
Lubricating oil consumption		kg/h	0.15	0.15	0.15	0.175	0.2	0.2
Lubricating oil volume		dm³	30/41	30/41	22/30	30/70	40/90	40/90
Weight-dry		kg	990	990	1300	1052	1420	1420
Generator								
Manufacturer			Marelli	Marelli	Marelli	Marelli	Marelli	Marelli
Model			MJB315MA4	MJB315MA4	MJB315MB4	MJB355SA4	MJB355MA4	MJB355MB4
Mode			Synchronous	Synchronous	Synchronous	Synchronous	Synchronous	Synchronous
Maximum rating		kVA	410	410	450	510	680	800
Continuous output		kVA	250	250	300	308	456	505
Rotating speed		r/min	1500	1500	1500	1500	1500	1500
Efficiency		%	95.3	95.3	95.9	96.0	96.2	96.4
Voltage		V	400	400	400	400	400	400
current		A	289	289	346	367	527	583
Frequency		Hz	50	50	50	50	50	50
Ingress protection class			IP23	IP23	IP23	IP23	IP23	IP23
Insulation system			H	H	H	H	H	H
Warming class			F	F	F	F	F	F

⁽¹⁾ Noise data recorded when complete with sound reduction housing.

The above quoted data is based on Natural Gas with a calorific value of 36.0 MJ/Nm³ (10.0 kWh/Nm³) and a Methane value greater than 80 Efficiency data was obtained under standard atmospheric conditions: air pressure 100 kPa, air temperature 298°K, relative air moisture 30%

Clamp power at generator with $\cos \varphi = 1.0$

Hoval follows a policy of continued improvement and reserves the right to change specifications without notice.

4.3. PowerBloc EG (43-70) Dimensions

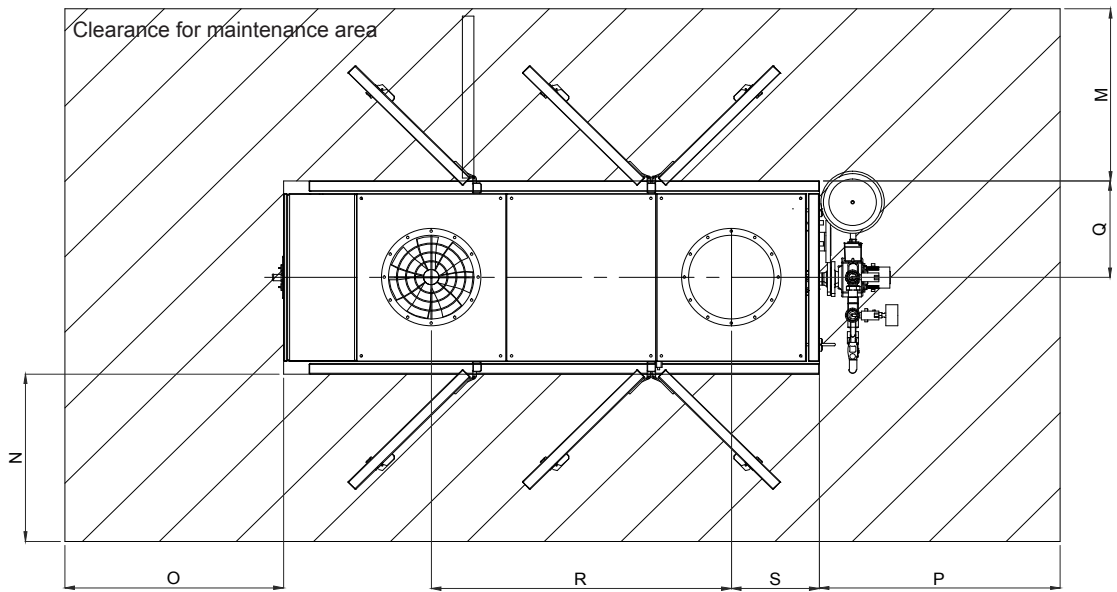
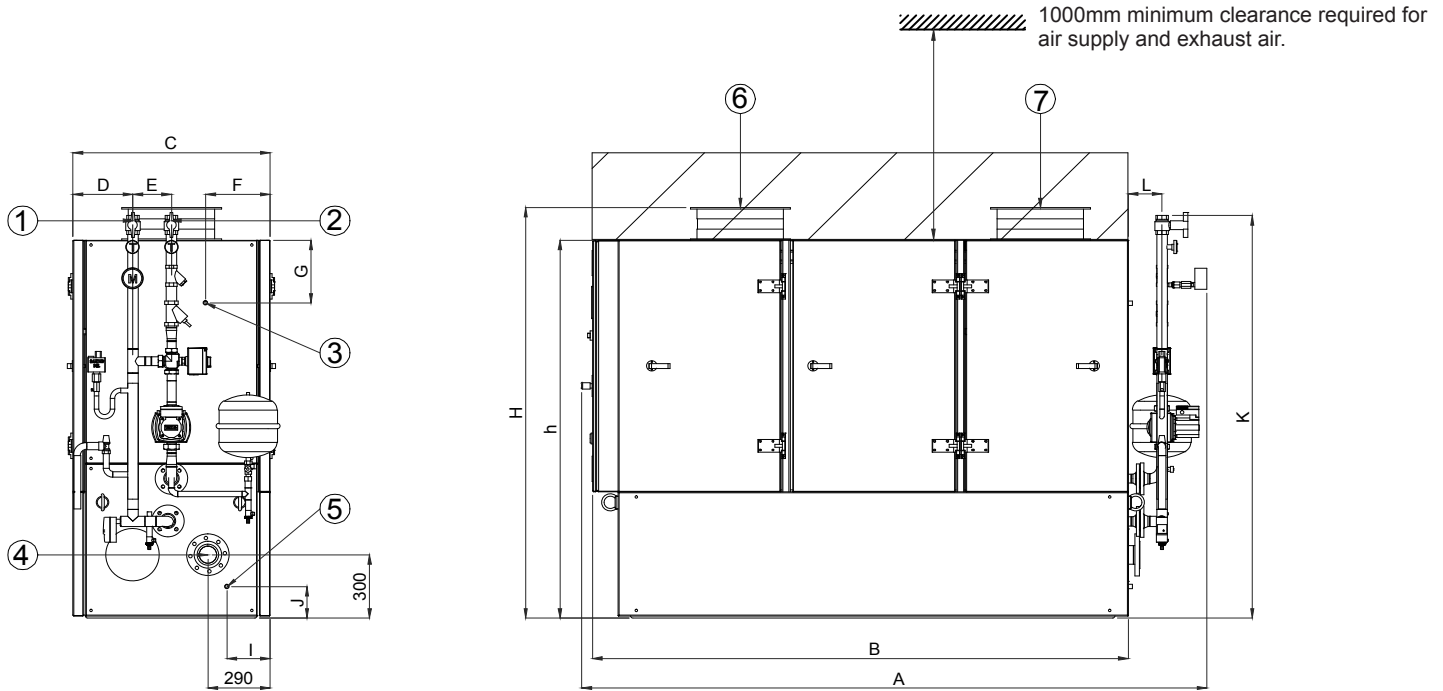

	1	2	3	4	5	6	7
Model	Flow	Return	Gas Inlet	Exhaust Outlet	Condensate Drain	Supply Air	Extract Air
EG-43	DN32	DN32	1"	DN80	1"	400mm	350mm
EG-50	DN40	DN40	1"	DN100	1"	400mm	400mm
EG-63	DN40	DN40	1"	DN100	1"	400mm	400mm
EG-70	DN40	DN40	1"	DN100	1"	400mm	400mm

Model	A	B	C	D	E	F	G	H	h	I	J	K	L	M	N	O	P	Q	R	S
EG-43	2950	2500	920	280	180	300	300	1955	1800	200	150	1810	150	1000	1000	1200	1500	460	1400	460
EG-50	2970	2500	920	280	180	300	300	1955	1800	200	150	1920	160	1000	1000	1200	1500	460	1400	460
EG-63	3580	3100	920	220	180	150	150	1955	1800	290	150	1840	220	1000	1000	1200	1500	550	2045	408
EG-70	3590	3100	900	195	180	150	150	1955	1800	290	150	1840	220	1000	1000	1200	1500	450	2045	408

4.4. PowerBloc EG (104-140) Dimensions

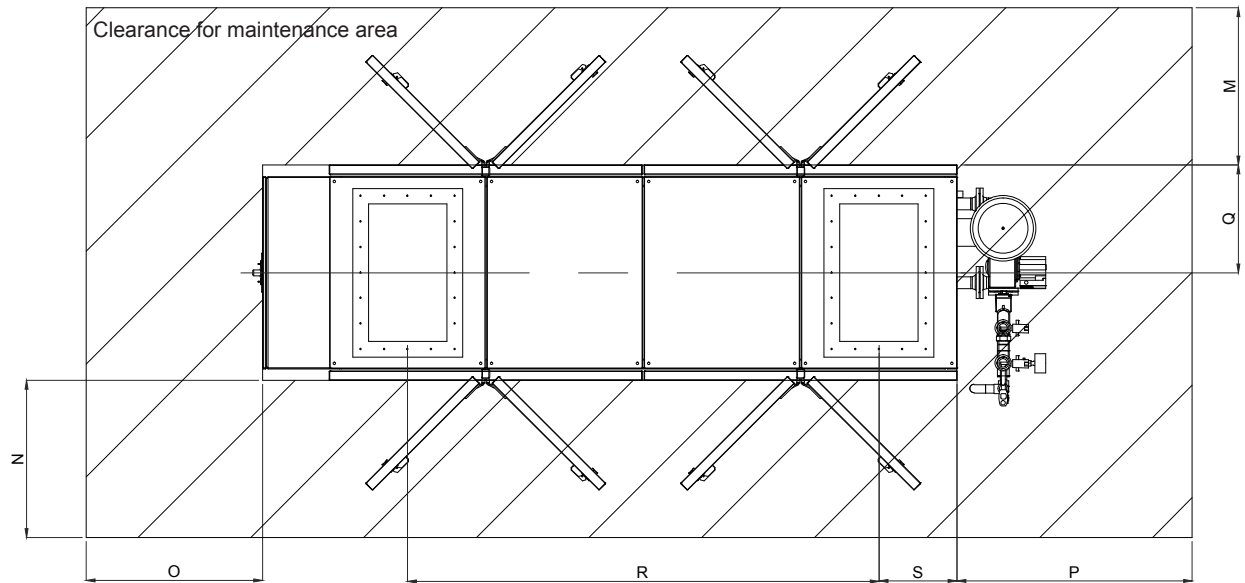
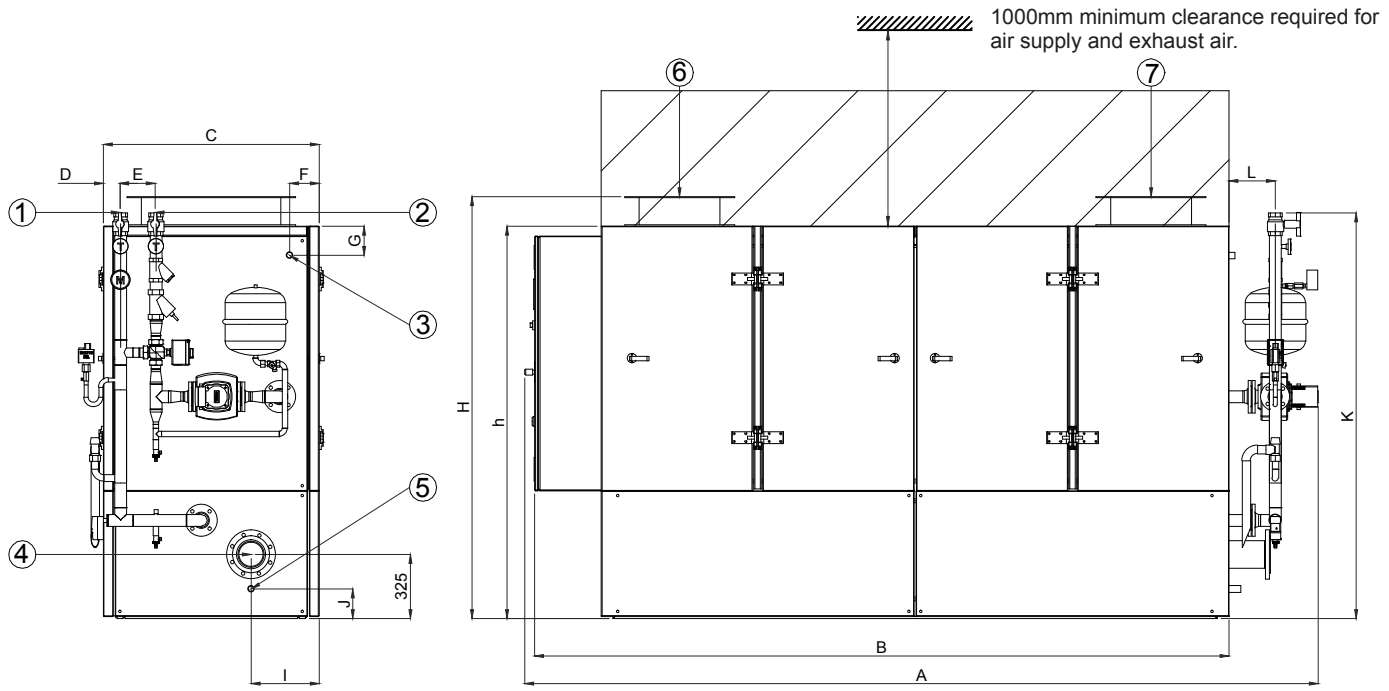

	1	2	3	4	5	6	7
Model	Flow	Return	Gas Inlet	Exhaust Outlet	Condensate Drain	Supply Air	Extract Air
EG-104	DN50	DN50	1 1/2"	DN125	1"	400x700mm	400x700mm
EG-140	DN50	DN50	1 1/2"	DN125	1"	400x800mm	400x800mm

Model	A	B	C	D	E	F	G	H	h	I	J	K	L	M	N	O	P	Q	R	S
EG-104	4045	3540	1100	90	180	150	150	2150	2000	345	150	2070	240	1000	1000	1200	1500	550	2384	408
EG-140	4050	3540	1100	170	180	150	150	2150	2000	345	150	2145	240	1000	1000	1200	1500	550	2384	408

4.5. PowerBloc EG (200-404) Dimensions

1000mm minimum clearance required for air supply and exhaust air.

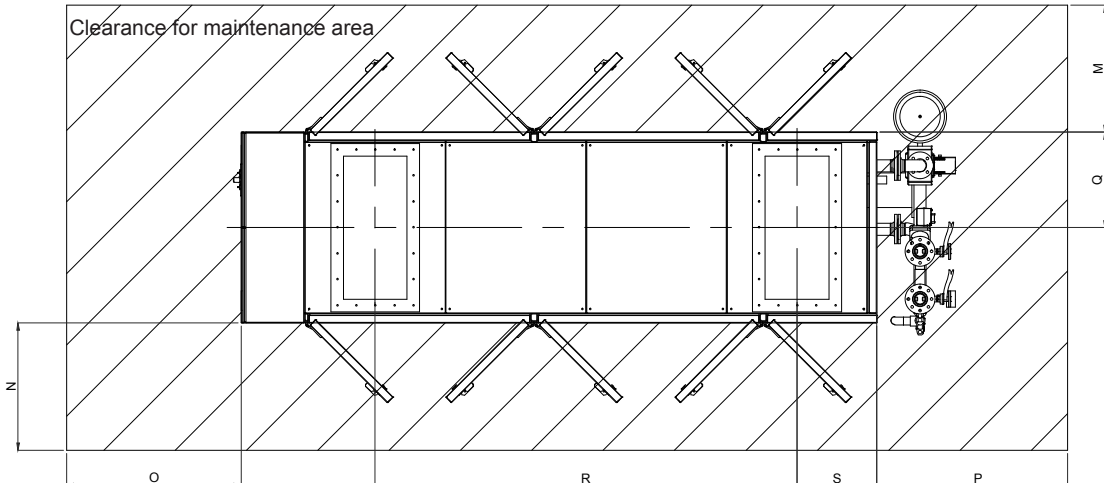
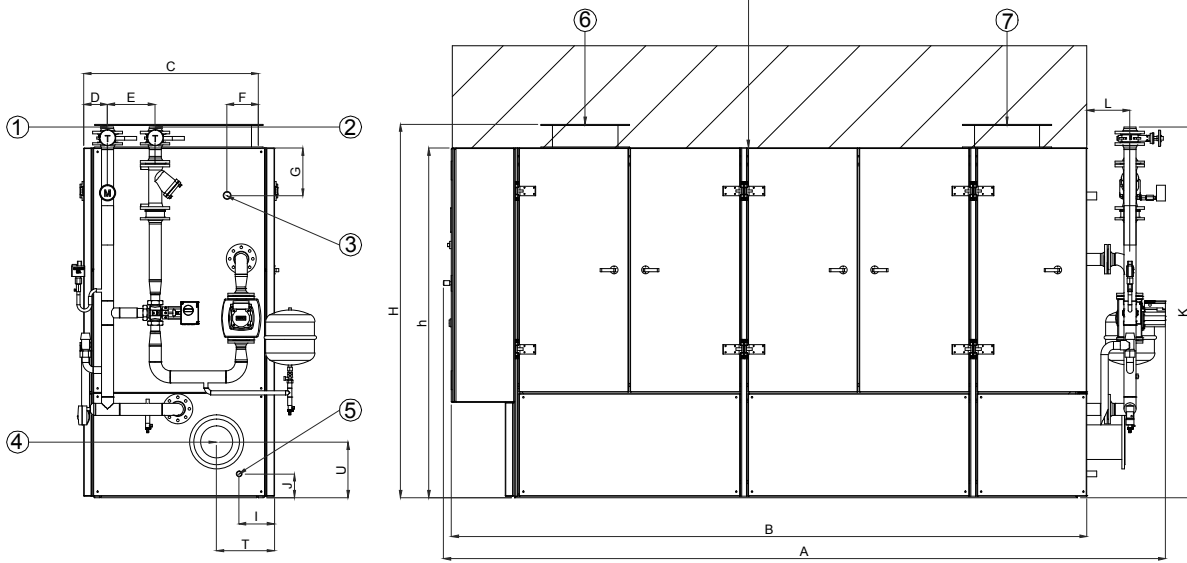

	1	2	3	4	5	6	7
Model	Flow	Return	Gas Inlet	Exhaust Outlet	Condensate Drain	Supply Air	Extract Air
EG-200\50	DN65	DN65	1 1/2"	DN150	1"	400x900mm	400x900mm
EG-200\80	DN65	DN65	1 1/2"	DN150	1"	400x900mm	400x900mm
EG-240	DN65	DN65	1 1/2"	DN200	1"	500x1000mm	500x1000mm
EG-250	DN65	DN65	2"	DN200	1"	500x1000mm	500x1000mm
EG-365	DN80	DN80	2"	DN250	1"	600x1000mm	600x1000mm
EG-404	DN80	DN80	2"	DN250	1"	600x1000mm	600x1000mm

Model	A	B	C	D	E	F	G	H	h	I	J	K	L	M	N	O	P	Q	R	S	T	U
EG-200\50	4545	4030	1260	180	300	300	300	2380	2230	395	150	2335	240	1000	1000	1200	1500	630	2654	533	395	350
EG-200\80	4545	4030	1260	180	300	300	300	2380	2230	395	150	2335	240	1000	1000	1200	1500	630	2654	533	395	350
EG-240	4790	4200	1600	427	300	300	300	2350	2200	250	150	2369	286	1000	1000	1200	1500	800	2890	458	450	500
EG-250	4790	4200	1600	427	300	300	300	2450	2200	250	150	2369	286	1000	1000	1200	1500	800	2896	452	450	500
EG-365	5520	4900	1720	371	300	300	300	2650	2500	250	150	2510	315	1000	1000	1200	1500	860	3596	452	570	500
EG-404	5535	4900	1720	371	300	300	300	2650	2500	250	150	2710	315	1000	1000	1200	1500	860	3594	454	570	500

5. Installation Requirements

Notes on installation and the Operation of the CHP plant

Regular preventative maintenance needs to be performed on the CHP plant to ensure it operates correctly. As well as these scheduled service visits the site operator needs to frequently check the CHP plant to ensure that everything is operating as designed.

5.1. Site Requirements

- A suitable flat, level and fire proof base must be provided to suit the flooded weight of the CHP plant concerned (not provided by Hoval).
- The CHP plant must be installed by competent persons and in accordance with the assembly instructions.
- The CHP plant must be commissioned by Hoval or by a specialist approved by Hoval.
- All building regulations must be adhered to in regards to the installation, the air duct work and the flue arrangement.
- All electrical regulations must be adhered to when connecting the power (i.e. G59 application must be completed if necessary).
- The relevant Gas standards must be adhered to when connecting the Gas pipe-work.
- All regulations with regard to the heating water system must be adhered to.
- All health & safety regulations applicable to the plant must be adhered to at all times.

5.2. Additional Notes for the Installer

When installing your new CHP plant you need to be aware of several items:

Vibration Insulation Mat

Rubber Vibration Insulation Matting is provided with the CHP plant, supplied loose. When the CHP is sited these insulation strips should be placed under the framework of the skid arrangement before services are connected.

Flexible Pipe Connections

It is imperative that the incoming gas pipe, the heating system flow pipe, the heating system return pipe and the exhaust connection are all connected to the CHP skid with flexible connections. This is so the vibrations of the engine are not transmitted through the pipework back through the building.

Condensate Drains

The condensate from the exhaust connection must be piped to drain in Stainless Steel. A suitable trap must be fitted in line before reaching the drain point. Note this must all be done in Stainless Steel.

Electrical Connections / Cable Management

Any links between the CHP plant and the cable management must be done so with flexible connections. All cable management (trunking, conduit, cable tray) must not be fixed to the CHP plant.

Existing Electrical Supply

Please be aware the voltage on site must be within the tolerances of the current standards. The electrical loadings on each phase must be within 10% of one another. For example if L1 is 1000A then L2 and L3 must be between 910A and 1000A or 1000A and 1100A.

5.3. Readiness for Operation

Gas Supply

A supply of gas at the required quality (see technical data table). This must be above the minimum pressure of 18mbar at full output, and at all times the CHP plant is operating.

Lubricating Oil in the Engine

The engine oil must always be filled to the correct level with a suitable lubricant. Details of the oil specification can be found in the engine manual.

Cooling Water

The coolant must be maintained at the required level. The coolant circuit is pressurised so must remain sealed at all times. The coolant must be to the appropriate standard as specified in the engine manual to ensure adequate protection against corrosion.

Heating Water

The heating water circuit to extract heat from the CHP plant must meet the minimum quality (see detailed specification further in the manual). The circulation pump for this circuit must be operational and above the stated minimum flow rate.

Starter Battery

The battery should always be fully charged and the fluid level maintained to its upper marking.

5.4. Further Important Information

- The installation of the CHP plant must be reported to and approved by the relevant energy supply companies.
- Certificates must be available prior to commissioning from the appropriate specialists for the gas purge test and also a pressure test for the exhaust system.
- Approval must be sought before piping the condensate to drain.

5.5. Waste Disposal

The disposal of any un-needed items such as packaging should be done so in an environmentally friendly manner.

Upon servicing the waste lubricating oil must be disposed of correctly. Proof of disposal must be documented and archived.

Modifications

Modifications to the CHP plant without written approval are not permitted.

6. Water Quality

6.1. Heating Water



The European Standard EN 14868 and the directive VDI 2035 must be observed.

In particular, attention must be paid to the following stipulations:

- Hoval CHP units are designed for heating installations without significant oxygen intake (plant type I according to EN 14868). Installations with
 - Continuous oxygen intake (e.g. underfloor heating systems without diffusion proof plastic piping) or
 - Intermittent oxygen intake (e.g. where frequent refilling is necessary)

Must be equipped with separate circuits.

- Treated filling and replacement water must be tested at least annually with the results logged and available. According to the inhibitor manufacturer's instructions, more frequent testing may be necessary.
- Refilling is not necessary if the quality of the heating water in existing installations (e.g. exchange of the CHP unit) conforms to VDI 2035. The Directive VDI 2035 applies equally to the re-placement water.
- New and if applicable existing installations need to be adequately cleaned and flushed before being filled. The CHP unit may only be filled after the heating system has been flushed.

- Parts of the CHP plant which have contact with water are made of ferrous materials and stainless steel.
- A suitable freezing-protection agent should be used, if the CHP plant and associated pipework are likely to be subjected to temperatures below 2°C.
- The pH value of the heating water should lie between 8.3 and 9.5 after 6-12 weeks of heating operation.

Filling and replacement water

- For an installation using a Hoval CHP, untreated drinking water is generally best suited as the heating medium, i.e. as filling and replacement water. However, as not all drinking water is suitable for use as filling and replacement water the water quality must fulfil the standard set in VDI 2035. Should the mains water available not be suited for use then it must be desalinated and/ or be treated with inhibitors. The stipulations of EN 14868 must be observed.
- In order to maintain a high level of efficiency and to avoid overheating of the heating surfaces the values given in the table should not be exceeded (dependent on boiler performance ratings - for multi-boiler plants rating of smallest boiler applies - and on the water content of the plant).
- The total amount of filling and replacement water which is used throughout the total service life of the CHP unit must not exceed three times the water capacity of the plant.

Water Specification Limit Values

Electrical conductivity	(μS)		< 100
Oxygen	(O_2)	mg/l	< 0.05
Chloride		mg/l	< 20
Copper	(Cu)	mg/l	< 0.05
Total Iron	(Fe)	mg/l	< 0.05
Alkaline earths		mmol/l	< 0.02
Total hardness		°dH	< 0.1
Phosphate	(PO_4)	mg/l	5 - 10

7. Typical Pipework Schematics

7.1. CHP in Parallel

The most efficient way of operating a CHP installation providing the Building Management System has the appropriate controls.

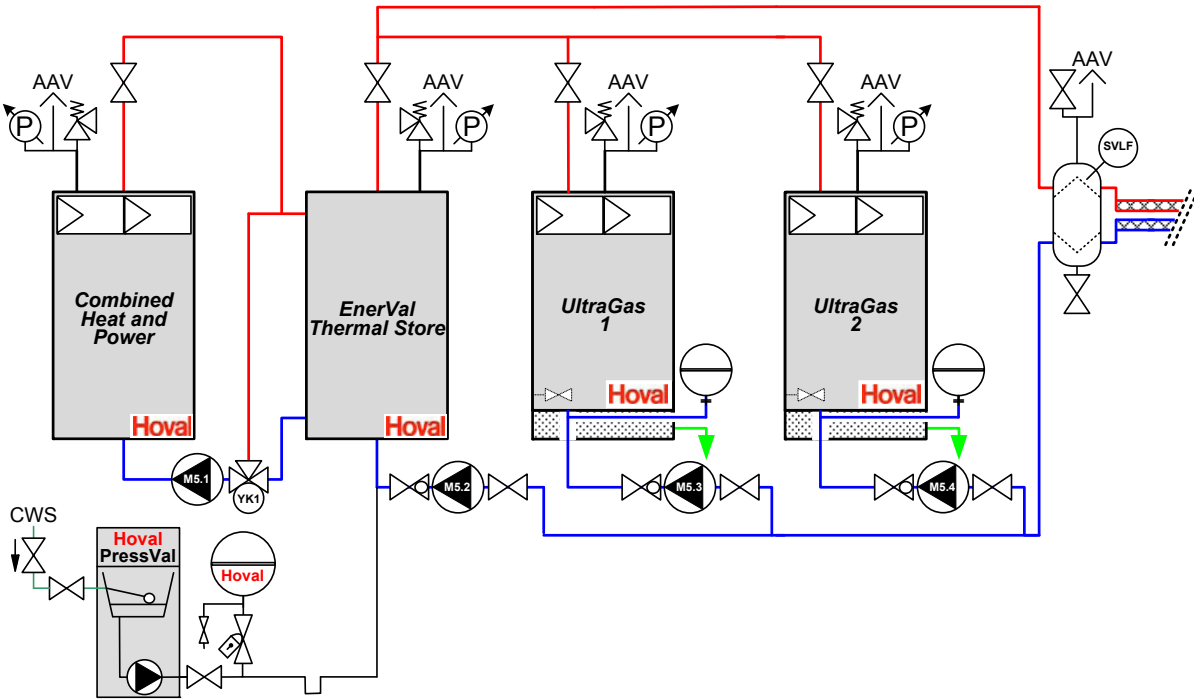

7.2. CHP in Series

The easiest way of fitting the CHP into building with a limited control system. This arrangement works by pre-heating the return to the boilers.

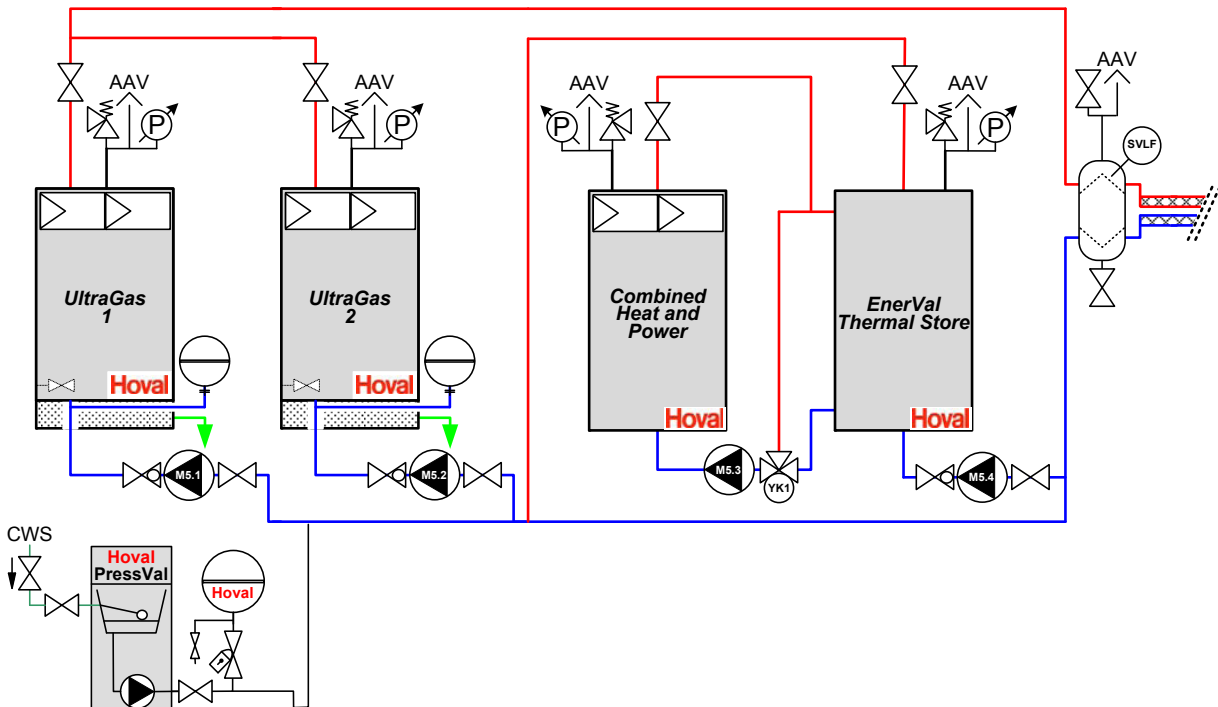

Note: The above schematics are indicative and only show the basic principle. All installations should be in accordance with local regulations.

8. Construction

8.1. Construction of The CHP Plant

- A skid-mounted unit complete with an optional sound reduction capsule or mounted within an insulated container installed complete with heat exchangers and exhaust gas silencer.
- Combustion air and all ventilation requirements are met with the fan-assisted inlet and extract air system.
- All pipe work to the flanged connections and the heat exchangers containing useful heat are fully insulated.
- Anti-vibration mounting points are used between the main frame of the skid and the engine and generator assembly stopping nuisance vibrations being transferred through the unit.
- Various information points and test points on the CHP plant are available on all of the water circuits and on the exhaust system.

8.2. The Gas Engine

A MAN gas engine with spark ignition is used in the CHP plant. This engine has electronic speed control with automatic ignition complete with all required filtration, lubrication and cooling systems required. The full specification of the engine as follows:

- Crankcase with cylinder block in one piece, made of cast iron, sealed at the bottom by an oil sump and at the rear by the flywheel control housing
- Cylinder heads with moulded-in vortex intake ducts and valve seat inserts shrunk into the cylinder heads
- Light alloy pistons, cooled by pressurised oil from oil injection nozzles
- Angled connecting rods, a crankshaft with 7 bearings, steel-backed cast lead bronze bearing shells
- Valves mounted vertically and with replaceable valve guides
- One inlet valve and one outlet valve per cylinder, camshaft mounted on 7 bearings
- Forced-feed lubrication with oil filter in the main flow and cooling by means of oil cooler
- Automatic oil refill device
- Crankshaft ventilation with oil separator and connection to combustion air
- Closed-circuit engine cooling, pump with three-phase motor, safety valve and expansion tank
- Air intake via dry-air filter, directly from the installation room via supply air device
- Pre-engaged drive starter motor 24V
- Electronic high-performance ignition with solid-state low-voltage distribution, one ignition coil per cylinder
- Gas-air mixer, gas control damper for output and speed control
- Actuator for speed and output control
- Turbo-charger and intercooler (on some models)

8.3. The Generator

The main components of the generator are the internally-poled rotor and the wound stator complete with exciter circuit and voltage regulator using an auxiliary winding. The three-phase alternating voltage induced in the exciter circuit is rectified via the rotating diode disc and fed to the generator revolving field. Voltage stabilisation for the main generator under alternating loads is maintained by changing the field current via the thyristor actuator in the voltage regulator.

8.4. Engine Cooling Water Heat Exchanger

The engine cooling water heat exchanger transfers the heat from the gas engine to the external heating water system. Inside the heat exchanger, the warm engine cooling water and the cooler heating water are in counterflow, ensuring optimum heat transfer. The heat exchanger hydraulically separates the cooling water and the heating water.

8.5. Exhaust Gas Heat Exchanger

In the exhaust gas heat exchanger, energy is recovered from the exhaust gas. The exhaust gas mass flow is routed over a water circuit flowing through the exhaust gas heat exchanger. The exhaust gas flows through the heat exchanger tubes on the primary side, thereby transferring its heat to the heating water (secondary side). The operating temperatures for the exhaust gas are approx. 600°C at the inlet and approx. 120°C at the outlet, and the operating temperature on the heating water side is approx. 90°C.

8.6. Engine Cooling Circuit

The cooling circuit of the gas engine is equipped with a separate expansion tank and pump which is routed via the engine cooling water heat exchanger. The engine cooling water is first routed into the cooling ducts of the engine housing, where it absorbs the transferred heat and then flows back into the engine cooling water heat exchanger. The engine cooling water heat exchanger transfers the heat to the heating water. The cooling water is always a mixture of antifreeze and a corrosion protection agent. For the full specification see the MAN manual.

8.7. Heating Water Circuit

The heating water circuit flows first through the engine cooling water heat exchanger and then through the exhaust gas heat exchanger. The CHP plant is equipped with a circulation pump which pumps a constant volume of water through the exchangers. In addition, a three-way valve is installed to regulate a constant return temperature of 70°C to the engine cooling water heat exchanger. The heat extraction system is also equipped with the relevant safety devices for temperature and pressure.

8.8. Exhaust Catalytic Convertor

The closed-loop three-way catalytic convertor and the oxidation catalyst in the case of turbocharged engines reduce the pollutants in the engine exhaust gases.

8.9. Ventilation

The CHP plant is equipped with a supply air fan which is operated in two stages. The first stage is designed to supply adequate combustion air to the engine and allow the radiant heat to be extracted. The second stage is switched on as required via a temperature sensor in the sound reduction capsule or container. The supply air is drawn in by a fan via an on-site supply air duct. The extract air should be routed to outdoors via an extract air duct (not by Hoval).

8.10. Monitoring Device

The engine and generator unit is monitored and controlled via a processor control system. All values of the engine, the exhaust and the heating water system are monitored in terms of pressure and temperature and then displayed on the touch-screen display. These values are then relayed out to a webpage for remote monitoring and can also be visible on the Building Management System (subject to the necessary interfaces being installed).

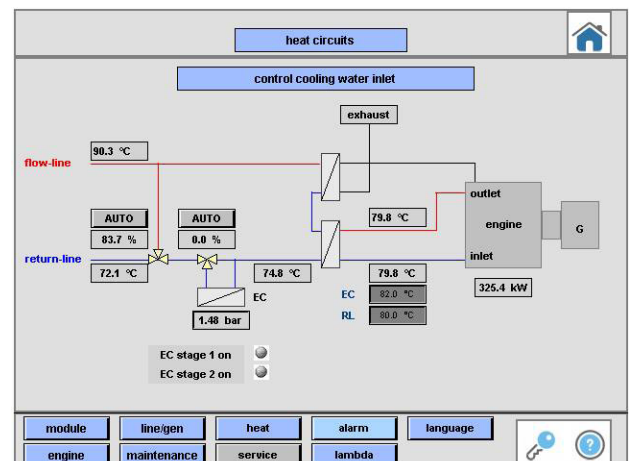

9. Functional Description

9.1. Functional Description of the CHP Plant

The gas engine directly drives the generator which then generates a current that is fed out to the distribution main. Excess electricity can then be exported to the utility grid providing the relevant approvals (G59) are in place.

A by-product of this power generation is heat produced by the gas engine. This is absorbed into the heating circuit via engine coolant and an exhaust gas heat exchanger. This method of energy production is commonly known as co-generation or combined heat and power generation because it simultaneously generates electricity and useable heat.

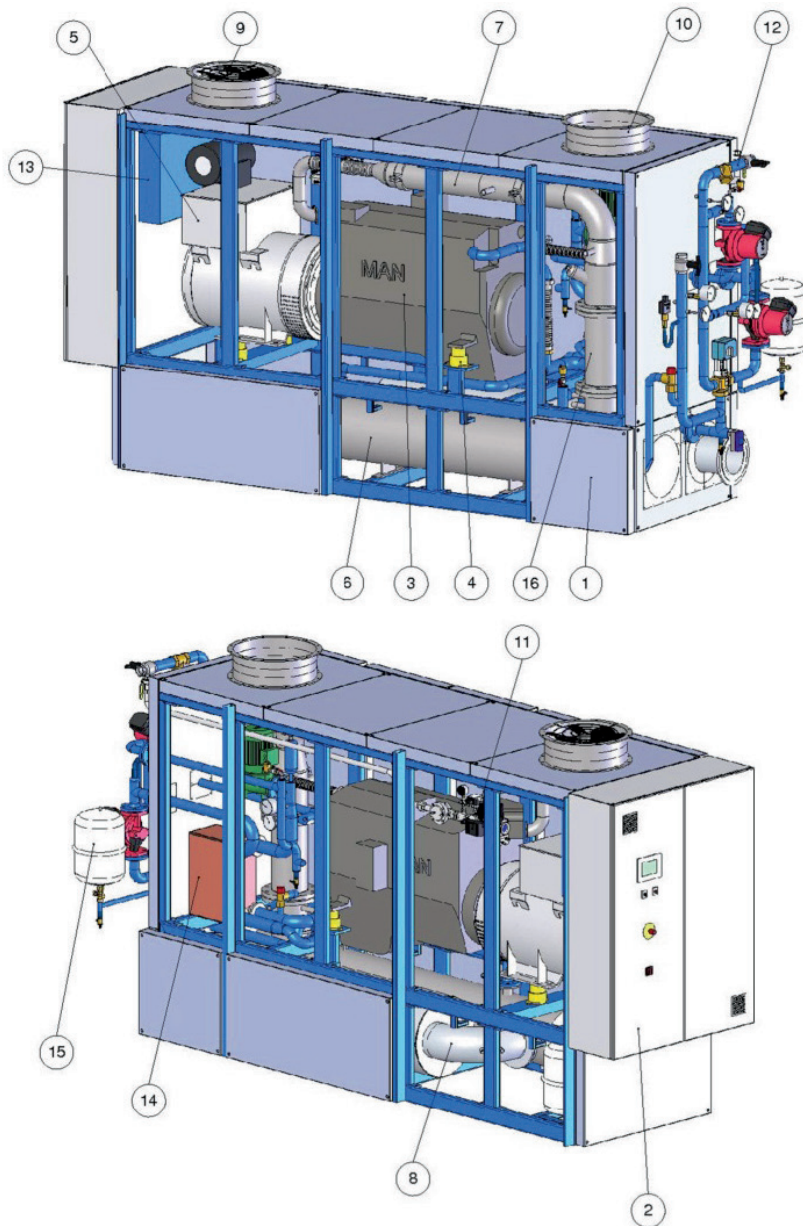

1. Sound reduction capsule (covers not shown)
2. Control panel
3. MAN gas engine
4. Anti-vibration mounts
5. Electrical generator
6. Exhaust gas heat exchanger
7. Exhaust gas pipe
8. Exhaust silencer
9. Ventilation air intake fan
10. Ventilation extract air duct connection
11. Gas train
12. Heating system components
13. Lubricating oil tank
14. Engine coolant heat exchanger
15. Expansion vessel
16. Catalytic convertor

10. Control Panel - Overview

10.1. Control Panel

The CHP plant control cabinet requires its own dedicated 3-phase 400Vac supply as this is used to operate all auxiliary equipment such as pumps and the ventilation fan. The control panel also incorporates a battery charging system to act as a main failure back-up and also as a supply for the engine starter motors.

All functionality is accessible from the front of the control cabinet. The control cabinet should only be opened for service purposes, by suitably qualified and trained personnel.

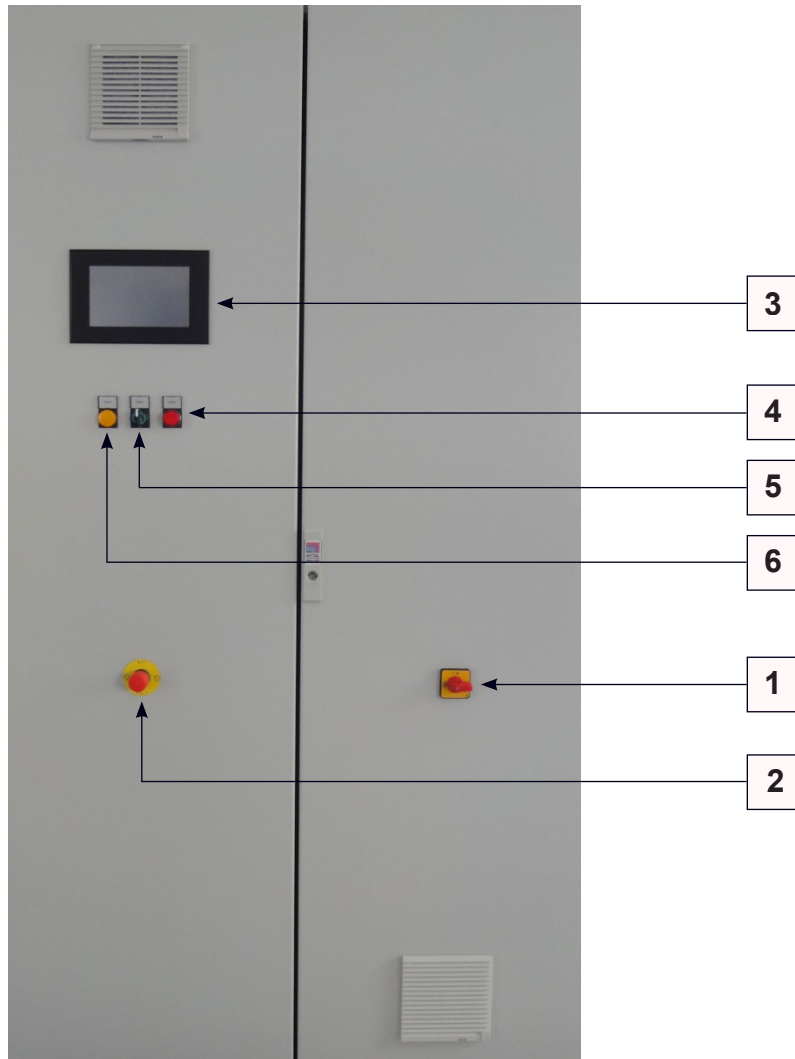

1. Door mounted isolator

The door mounted isolator immediately stops the engine and inhibits it from operating. Note that the fans and the lighting (if supplied containerised) are still live after switching off the door mounted isolator.

2. Emergency stop button

The emergency stop button immediately shuts down the engine. The auxiliary circuits are switched off when this button is pressed. To avoid an overheating condition due to latent heat within the engine the Manual/Automatic switch should be put to '0' and the emergency stop released. The RESET should then be pressed, this will then restart the pumps to cool the engine.

Note: On a containerised CHP unit an external emergency stop button (with break glass) along with an alarmed gas detection device are also supplied.

3. 7" graphic touch display

The main control functionality of the CHP plant is accessed using the touch screen controller. This will display all operating conditions and allow the adjustment of parameters providing the correct service codes have been input.

4. Red RESET/Fault illuminated pushbutton

The red light will illuminate when the CHP plant is in a fault condition. A detailed description of the fault is available on the touch screen controller in the alarm menu. If the fault condition has cleared then this button can then be pressed for 3 seconds to clear the fault.

5. M-0-A illuminated selector switch (Manual – Off – Automatic)

When illuminated, this indicates that the CHP plant is running. The selector switch has three positions:

- Manual: The CHP plant will start up and control to the set-point set on the display.
- Off: The CHP plant will be in an "off" condition.
- Automatic: The CHP plant will control dependant on the signals received from the Building Management System.

6. Yellow warning indicator lamp

The yellow lamp will illuminate when the CHP plant is in a warning condition. The warning condition will not stop the machine. If the minor problem is not rectified and worsens this will then develop into a fault. A detailed description of the warning is available on the touch screen controller in the alarm menu.

10.2. Overview of Functionality

All of the control processes for efficient and safe operation are carried out by the controller within the CHP plant control cabinet. Below is a brief overview of these main functions:

- Manual and automatic operation
- Complete CHP safety system with warning messages and self protection
- Mains and generator monitoring
- Automatic engine starter
- Electronic speed control for the rotating assembly
- Synchronisation, frequency and power output control
- Electrical output control
- Flow temperature control
- Mains back-up operation (optional)
- Remote diagnosis and interrogation available
- Operating hours, service hours, start and kWh counter.

10.3. Manual and Automatic Operation

The operating mode is selected with the mode selector switch on the control cabinet door. This switch has three positions, Manual - Off - Automatic.

Manual mode is available to operate the CHP plant on site without the need for a Building Management System. This will then automatically control to a set-point on the touch screen.

Automatic mode allows the CHP plant to respond to an external start/stop signal as well as an analogue control signal to adjust the set-point for site requirements.

When the switch is positioned to '0' the unit will perform a safe shut-down and then stop.

10.4. Safety System

The CHP plant contains its own safety protection to ensure the correct running of the equipment. There are two tiers of safety within the CHP controls, firstly the warnings and secondly the faults. There are multiple information points measured: engine speed, water pressure, mixture pressure, water temperature, oil temperature, exhaust temperature, battery voltage, and oil level.

10.5. Grid Monitoring

The CHP plant controller has a function where it monitors the electricity from the national grid. In the event of a fault it will disconnect from the national grid in approximately 100ms. The following signals are monitored: Overvoltage/undervoltage, over-frequency/under-frequency and vector surge.

10.6. Generator Monitoring

The CHP plant controller also monitors the generator in the same way as it monitors the electricity from the national grid. The following electrical signals are monitored: Overvoltage/undervoltage, over-frequency/under-frequency, over-current, reverse power and differential current.

10.7. Engine Control

The touch-screen controller operates the engine and has the following control: Safe start and shutdown, starter and ignition, control of both gas valves, control of auxiliary equipment, speed control, engine over-run control and gas leak detection.

10.8. Speed Control

The CHP plant controller has a speed regulator to control the engine between 1440 and 1560 rpm. This controller will ramp the engine up to this speed on start-up and down from this speed when it is in its cool-down cycle. When the generator is synchronised this speed is maintained by the frequency from the grid.

10.9. Power Output Control

When the CHP plant is synchronised the control is switched from speed control to power set-point control. In automatic mode this set-point is derived from the building management system controls but in manual this set-point is input on the touch screen controller. The safety circuits can interrupt this set-point, for example if a warning signal is apparent the CHP plant will run at the pre-set reduced set-point.

10.10. Lambda Control

In order to respond to minor changes in the gas quality, the exhaust gas is measured with a lambda sensor. This acts to automatically adjust the fuelling to suit the current site conditions.

10.11 Touch Screen Display

The display is used as the interface to the CHP, showing all measured values as well as any error or warning messages. All of the operating parameters can be adjusted although the manufacturer's access code is required to do this.

11. Controls Overview

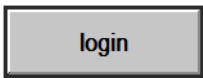

The service menu is restricted from unauthorised access. Pressing the login button allows access to input the password. Here you can either log in at **user** or **service level**.

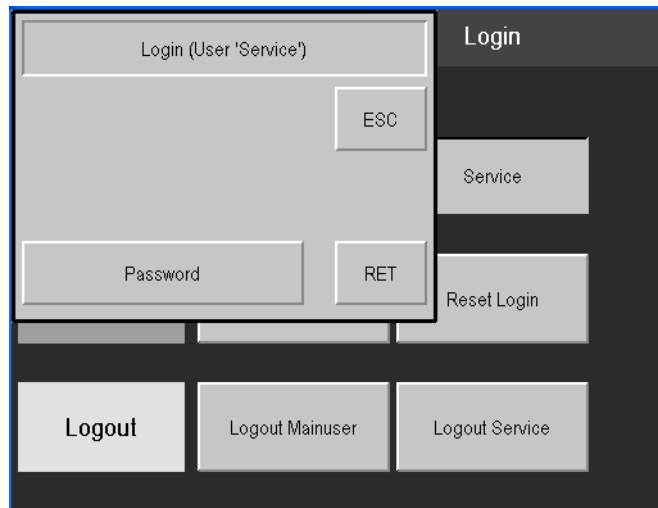
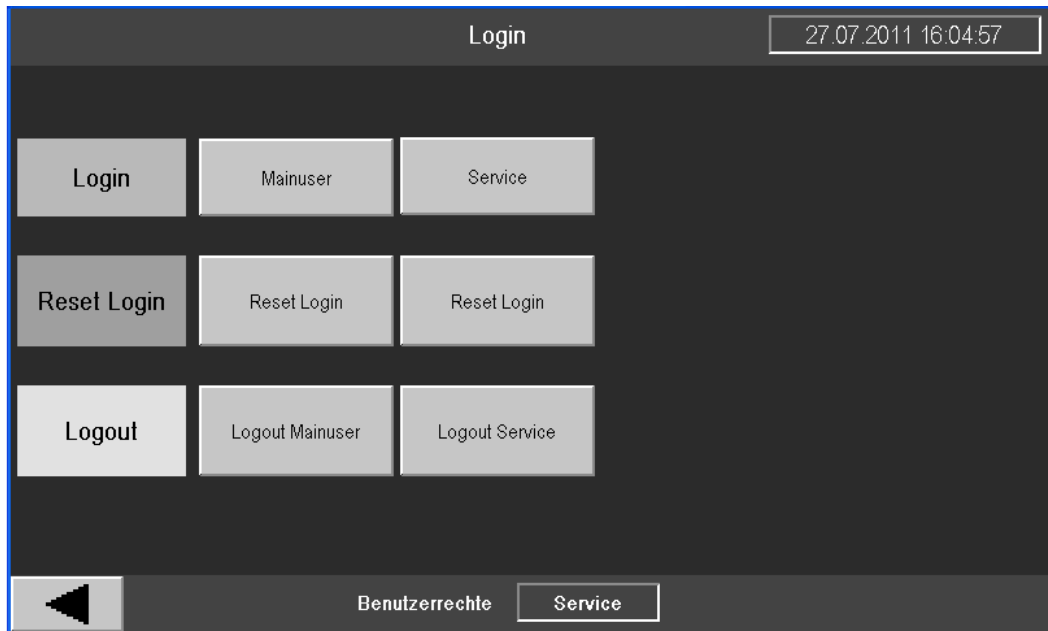

If the entered password is valid the authorisation will change at the bottom of the screen.



Please note to change any of the values explained in this manual you must first log in at the user level as detailed above.

Overview of Start Screen

The start screen provides an overview of the CHP outputs and a display of the accumulated running hours with the kWh produced.

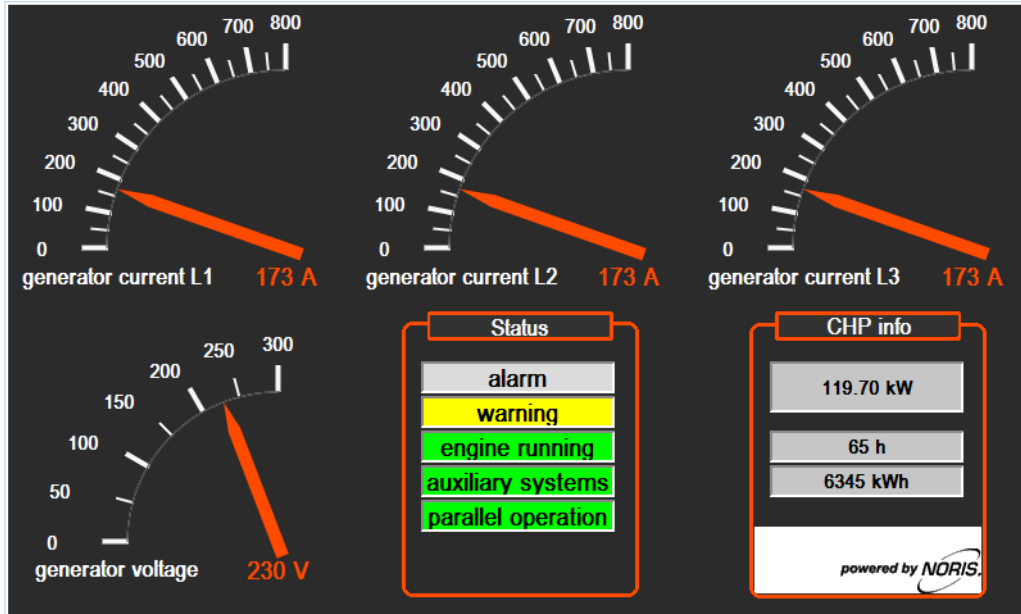

The main menu opens by tapping anywhere on the touch screen.

You can go back to the previous page by tapping this arrow button from any other screen.



Main menu

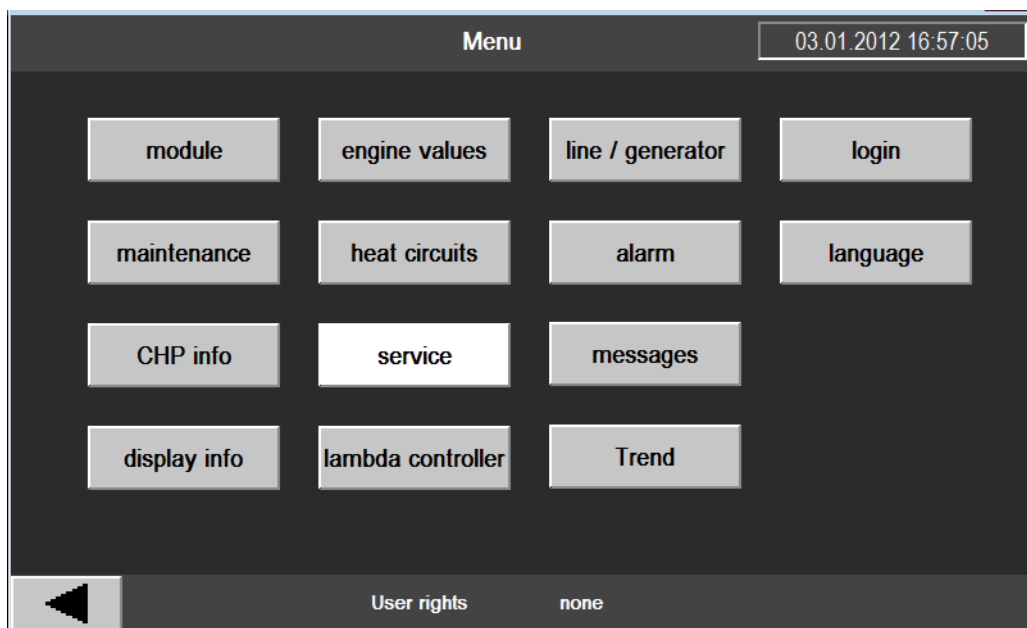

To display actual values and operate the CHP controller, the sub-menus, which are described in the following pages, are accessed by tapping the corresponding touch screen buttons shown in the menu.

module

This menu item shows an overview of the current status of the CHP plant.

The following set-points can be set for the power output in the top left area (**only to be adjusted by Competent personnel**):

- Set-point for manual mode
- Set-point for power reduction mode

The signals from the Building Management System are shown in Automatic mode in the bottom right area.

module				03.01.2012 17:03:43	
power reference value manual ctrl.	75.0 kW	counted starts	35		
setpoint power reduction	100.0 kW	operating hours	65 h		
active power setpoint	75.00 kW	service hours	65 h		
real power	119.70 kW	service hours max.	400 h		
apparent power	119.71 kVA	cabin temperature	33.28 °C		
reactive power	-1.89 kVAr	automatic operation			
energy	6368 kWh	requirement	OFF		
		power setpoint	0.0 %		
		User rights	Mainuser		

engine values

The important engine operating values are displayed in the engine values section.

engine values				03.01.2012 17:06:59	
speed 1	1500 rpm	exhaust temperature after bank 1	684 °C		
speed 2	1499 rpm	exhaust temperature after Bank 2	686 °C		
cooling water engine inlet	79.5 °C	exhaust temperature before catalytic	0 °C		
cooling water engine outlet	85.0 °C	exhaust temperature after catalytic	0 °C		
cooling water pressure	1.96 bar	exhaust after heat exchanger	245 °C		
oil temperature	97.6 °C	mixture temperature	50.2 °C		
oil pressure	7.53 bar	mixture pressure	1.32 bar		
		level oil sump	82.2 %		
fan stage	1 ON 2 ON	battery voltage	26.7 V		
		User rights	Mainuser		

line / generator

The important generator information is displayed on this screen. The active bar graphs on the right show the current outputs of the generator.

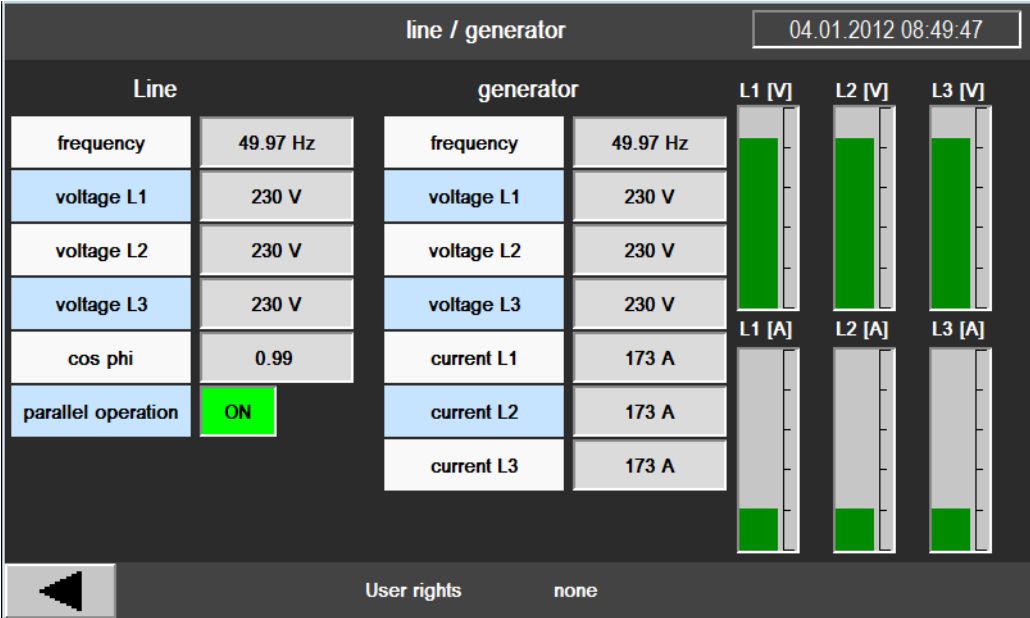

maintenance

The maintenance menu is important for being able to view when the next service is required. Here you also have the button where you can reset the service hours when a service has been performed. Please note, access codes will be required.

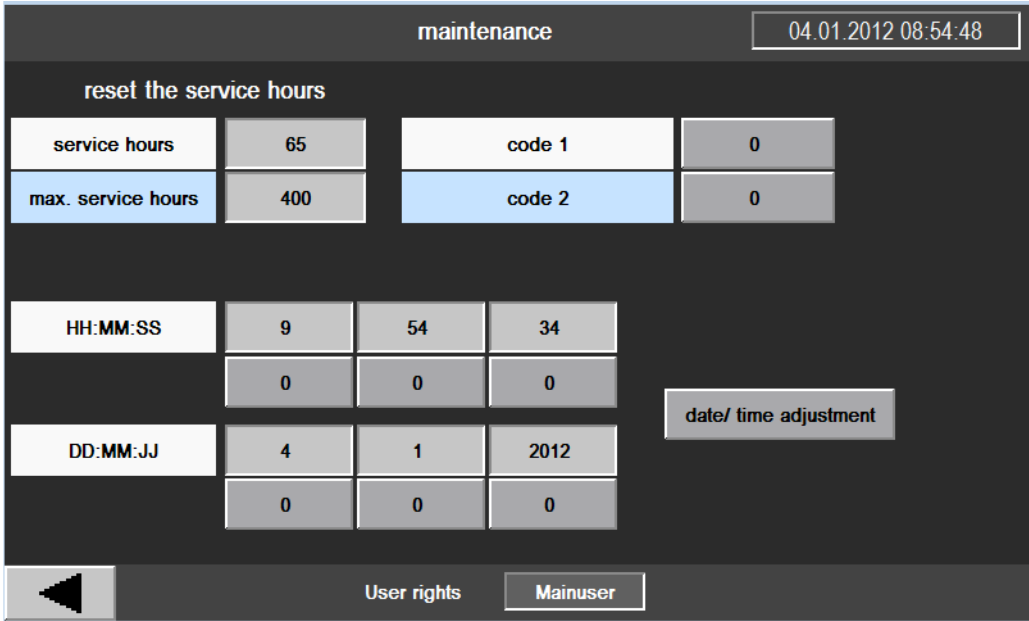

heat circuits

The heating circuits on the CHP plant controller can be viewed and adjusted in this menu.

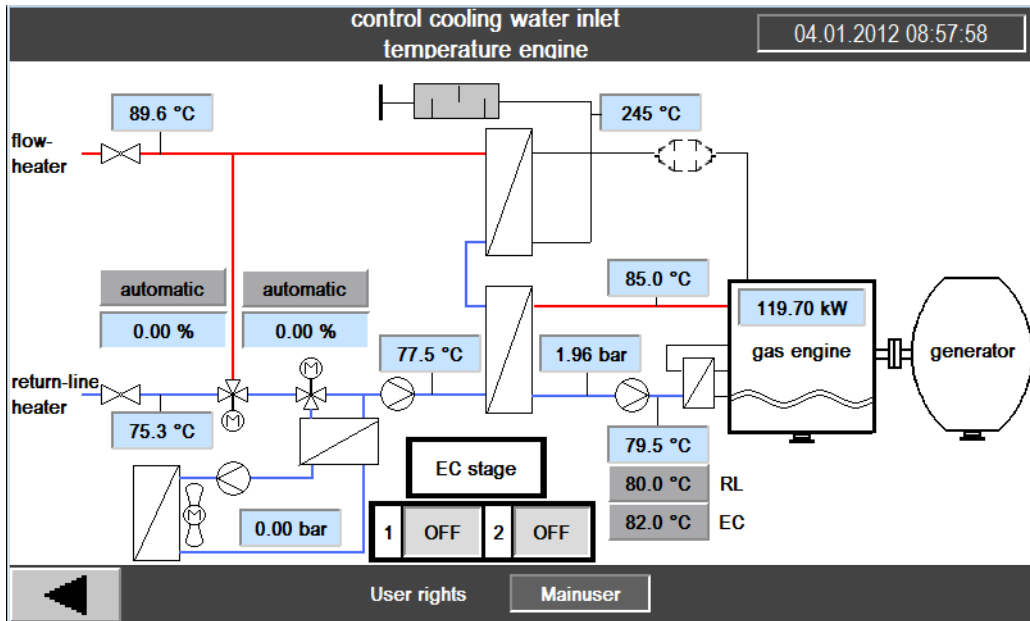

The set-point values for the control circuit can be set by buttons. A keypad for entering the target value opens up when the button is pressed. **Please note only authorised and trained personnel should make any adjustments.**

80.0 °C	RL
82.0 °C	EC



EC - Emergency Cooling

Temperature set-point for engine inlet cooling water maximum temperature. If this set-point overshoots the engine is cooled via the emergency cooling system.

RL - Return Temperature Boost

Temperature set-point for engine inlet cooling water minimum temperature. When the temperature drops below this value the temperature is boosted by reducing the heat extraction function.

The 3-port mixing valves for return temperature control or emergency cooling control can be operated in manual mode for test purposes. This is accessed by the window below when you select manual operation.

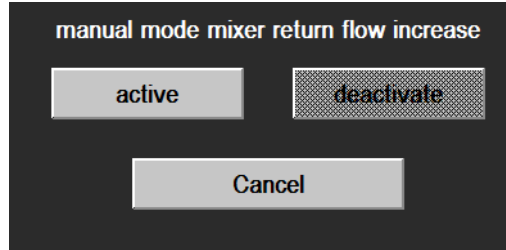

When active is selected the valve will display "manual" on the schematic. The set-point for manual mode is entered as a valve position. This is a value from 0-100%. When in manual mode the warning lamp will illuminate and a warning message will be displayed in the alarm list.

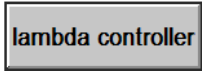
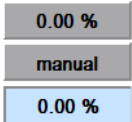

The lambda value for the engine to control this setting automatically can be set within this menu. It is advised that this is not adjusted unless you are a competent, trained engineer.

For more detailed information regarding the lambda menu please see the Noris Automation controls manual. This menu should only be entered by a competent, trained engineer.

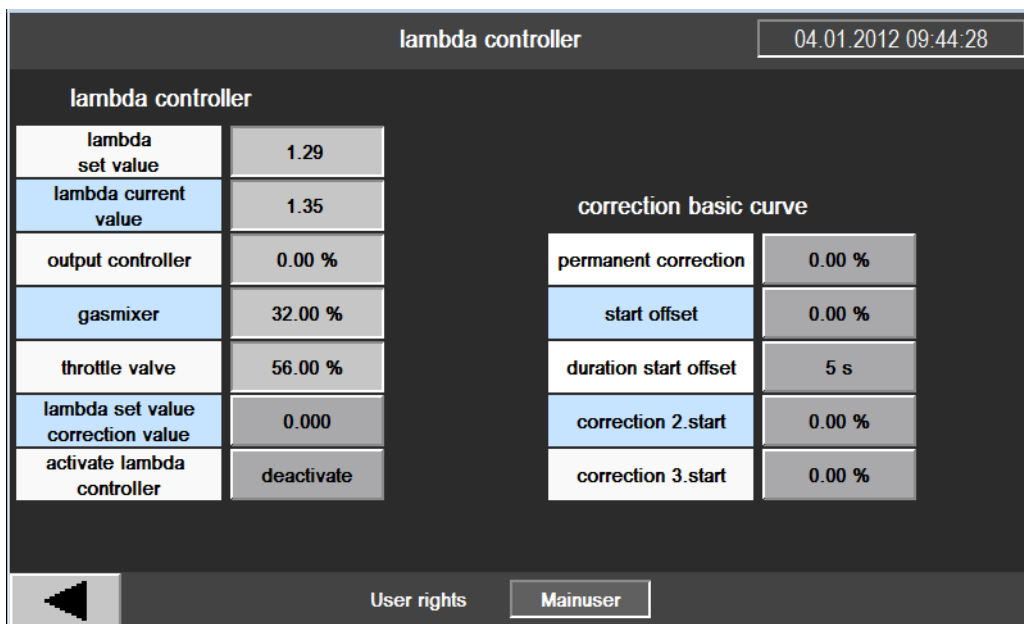

service

Settings in the service menu must only be adjusted by competent and trained persons. All options within this menu are described within their menu sets.

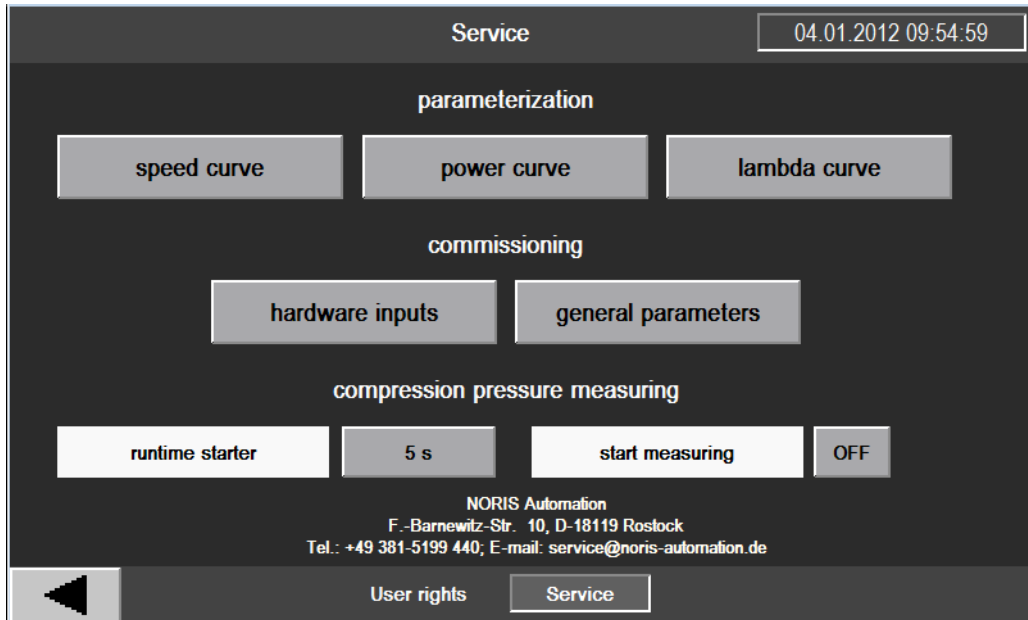

12. Pre-Commissioning

12.1 Engine

- Site must have sufficient access for the delivery and removal of the engine oil containers
- Only use engine oil as approved by MAN
- Fill engine with oil as detailed in the MAN assembly instructions
- The oil level should never exceed maximum
- The engine must be checked for oil leaks.

Coolant must be mixed correctly and added to the coolant circuit. This coolant must be of a suitable specification and approved by MAN engines. The coolant circuit must be fully de-aerated.

12.2. Oil Supply

- Fill the lubricating oil tank observing all safety and environmental regulations
- Check for leaks.

12.3. Gas Supply

- Approval must be in place for the use of Natural Gas
- Gas purge test and tightness test certificates need to be available prior to commencement of commissioning
- The Natural Gas supply must be installed to the current industry standards.

12.4. Heating Water System

- The heating water system must have been flushed, filled and de-aerated
- The water must be to the quality as specified earlier in this manual
- All safety equipment must be operational
- Sufficient pressure and flow must be available
- Heating load must be available for commissioning.

12.5. Electrical Connection

- A power cable for the CHP plant must be installed for the use of the auxiliary equipment
- Cabling must be installed to export electricity
- Grid monitoring cabling must be installed to ensure synchronisation is possible
- Electrical earthing must be to current standards
- If applicable the G59 application must be in place and certification available
- All connections to the Building Management System must be in place
- An internet connection must be set-up to allow for remote monitoring
- All electrical connections must be tested to the latest relevant standards.

13. Maintenance and Servicing

13.1 Overview

The CHP plant must have its preventative maintenance carried out at the required intervals, as specified in the MAN engine manual. This must be performed and logged to keep the warranty valid. If a service is missed the warranty is void. All maintenance work on the CHP plant must be performed by a Hoval or Hoval approved Engineer using MAN approved components. Inadequate or improper maintenance to the CHP plant will cause severe damage that may not be repairable. Hoval accepts no responsibility for any damage caused by a lack of maintenance. For the full service schedule please refer to the MAN operating and maintenance manual for the specific engine.

Before commencing any work on the CHP plant all operating values displayed on the touch screen controller must be recorded.

A fault log must be kept to allow for conclusions to be drawn and help diagnose any problems.

The CHP plant must be safely shut down and be locked off from operating to ensure the plant does not operate while it is being worked on.

A permit-to-work system should be put in place by the operator prior to all such work being undertaken.

13.2. Oil Change

After the CHP plant has been switched off it should be left to stand for 10 minutes. After this time the oil consumption since the last service can be measured and the engine can be checked for any oil leaks. The oil can then be drained from the bottom of the sump until it is empty of oil, and the oil filters can then be replaced. Once the filters have been re-fitted and the drain valve closed, oil can then be added to the maximum level on the dipstick. Only use oil as specified in the MAN engine manual.

The maximum oil level should not be exceeded. Used oil should always be analysed in accordance with the MAN requirements.

13.3. Spark plugs

Depending on the service level performed the spark plugs must be either checked or replaced. When checking a spark plug the gap must be checked and adjusted if necessary. They should then be re-fitted to the engine and tightened to a torque of 27 Nm.

13.4. Air Filter

The air filter must be cleaned or replaced depending on the service level. The airbox must be checked to ensure it is making a good seal so that all air entering the engine is passing through the air filter.

13.5. Valve Clearance

As mechanical tappets are used on the Hoval CHP plant, the valve clearance must be checked as prescribed in the maintenance schedule and readjusted if necessary in accordance with the engine manufacturer's instructions.

13.6. Starter Battery

When the CHP plant has starter motor batteries, they must be checked for any signs of leakage and the level of fluid checked. If they require topping up this must be done with distilled water.

Some CHP plants do not have starter batteries and are driven directly off the grid. In this case all cabling to the starter motor and the earthing must be checked.

13.7. Engine Coolant Pressure

If the coolant pressure in the engine is too low then this must be topped up. The correct ratio of water and antifreeze must be used. The antifreeze used must be to the correct specification as published in the MAN engine manual.

13.8. Generator

The generator electrical connections must be checked and cleaned each visit. Additional to this the generator should require no further maintenance.

13.9. Post Service

Upon completion of the service the maintenance hours must be reset on the touch screen controller. After a service, the service checklist must be completed and the CHP plant must be put back into automatic operation and restarted.

Important note: The above are for guidance only and the full servicing requirements are detailed in the MAN operations and maintenance manual for the specific engine.

14. Customer Service



14.1. Contacting Hoval

If you have any queries regarding the CHP plant please have to hand the serial number found on the data badge and the full address of the site.

Important Contacts:

Hoval Head Office: +44(0) 1636 672 711
 Hoval Service: +44(0) 1636 593 413
 Hoval Spares: +44(0) 1636 593 412

Below is an example of a typical data badge:

Hoval		Hovalwerk AG 9490 Vaduz, Fürstentum Liechtenstein, Auststrasse 70 phone +423 399 2400 fax +423 399 2411 www.hoval.com email: info@hoval.com	
Blockheizkraftwerk Typ YADO KWK EG-365			
Typenbeschreibung / Typ designation			
11110600051		2011-10	
Seriennummer / Serial number		Baujahr / Year of completion	
GB-NG24 1GN Newark Centre Parcs			
Anlagenstandort / Location			
Brennstoff / Fuel		Erdgas	
Elektrische Leistung / Electrical power	kW	365	
Thermische Leistung / Thermal Power	kW	496	
Energieeinsatz / Input	kW	955	
Stromkennzahl / CHP coefficient		0,74	
Spannung / Voltage	V	400	
Frequenz / Frequency	Hz	50	
Heizwasser Vorlauf / Heating water flow line	°C	90	
Heizwasser Rücklauf / Heating water return line	°C	70	
Technische Daten / Technical Data			

14.2. Remote Servicing:

Providing the internet connection has been successfully set-up and commissioned to the CHP plant, Hoval have the ability to log-in to the controller and potentially diagnose any issues you may have without having to wait for an Engineer to attend site.

15. Fault Finding

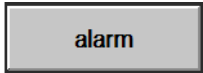

15.1.Alarms

Pressing the alarm button enters you into the current alarms menu. Here you will be able to see any current alarms or warnings and their current status. Alarms will be shown in red text and warnings shown in yellow text.

A history of alarms is shown when the current alarms button is pressed.

Fault status, 1 = current, 0 = fault cleared

Fault number

Date/time

Fault description

	Fault number	Date/time	Fault description
1	00535	04.01.12 09:50.13	safety stop failure gas cooler
1	00451	04.01.12 09:50.13	safety stop exhaust gas temperature after heat exchanger max.
1	00391	04.01.12 09:50.13	warning NSM relay enable missing
1	00338	04.01.12 09:50.13	warning manual mode mixer return flow increase
1	00333	04.01.12 09:50.13	warning error table cooler
1	00322	04.01.12 09:50.13	warning error Bus to the control system
1	00309	04.01.12 09:50.13	warning vector offset skip
1	00308	04.01.12 09:50.13	warning lineguard in the cabinet
1	00153	04.01.12 09:50.13	emergency stop fire alarm system
1	00143	04.01.12 09:50.13	emergency stop gas pressure line 1 min.
1	00132	04.01.12 09:50.13	emergency stop error feedback cooling water pumps
1	00131	04.01.12 09:50.13	emergency stop failure auxiliary systems
1	00118	04.01.12 09:50.13	emergency stop error cabinet

The alarm history is shown when the current alarms button is pressed.

	Fault number	Date/time	Fault description
1	00535	04.01.12 09:50.13	safety stop failure gas cooler
1	00451	04.01.12 09:50.13	safety stop exhaust gas temperature after heat exchanger max.
1	00391	04.01.12 09:50.13	warning NSM relay enable missing
1	00338	04.01.12 09:50.13	warning manual mode mixer return flow increase
1	00333	04.01.12 09:50.13	warning error table cooler
1	00322	04.01.12 09:50.13	warning error Bus to the control system
1	00309	04.01.12 09:50.13	warning vector offset skip
1	00308	04.01.12 09:50.13	warning lineguard in the cabinet
1	00153	04.01.12 09:50.13	emergency stop fire alarm system
1	00143	04.01.12 09:50.13	emergency stop gas pressure line 1 min.
1	00132	04.01.12 09:50.13	emergency stop error feedback cooling water pumps
1	00131	04.01.12 09:50.13	emergency stop failure auxiliary systems
1	00118	04.01.12 09:50.13	emergency stop error cabinet

15.2. Fault Codes

When monitoring the CHP plant over the internet and using the remote monitoring software the faults will be denoted by the letters WA, SS or ES followed by a fault number.

Key

WA – Warning – The CHP plant will continue to run as this fault is only a warning that should correct itself. For all Warning faults subtract 200 from the fault number.

SS – Safety Shutdown – The CHP plant will safely shutdown then resume operation once the issue is rectified. If the same fault happens three times within 24 hours a manual reset will then be required. For all Safety Shutdown faults subtract 400 from the fault number.

ES – Emergency Stop – The CHP plant will shut down immediately and require manually resetting before resuming operation.

Example: Fault Code SS 402, this will be a safety shutdown due to excessive generator current L2. This is worked as $402 - 400 = 002$.

Fault No.	Description
001	- generator current L1
002	- generator current L2
003	- generator current L3
005	- return power
007	- overspeed 1
008	- no speed signal (pick_up)
009	- overspeed 2
010	- gas mixer 1
012	- butterfly valve
013	- battery voltage
016	- level oil sump max.
017	- level oil sump min.
018	- cooling water pressure max.
019	- Cooling water pressure min.
020	- lubrication oil pressure max.
021	- lubrication oil pressure min.
024	- mixture pressure
029	- cooling water temperature engine inlet
030	- cooling water temperature engine outlet
031	- power reduction and cooling water temperature engine outlet
032	- oil temperature
033	- power reduction oil temperature min.
035	- mixture temperature
036	- power reduction, high mixture temperature
040	- return temperature heating circuit before mixer
041	- power reduction, high return temperature before mixer
042	- return temperature heating circuit after mixer
043	- flow temperature heating circuit
045	- cabin temperature
046	- room temperature
047	- exhaust gas temperature after bank 1
048	- exhaust gas temperature after bank 2
049	- exhaust gas temperature before catalyst

Fault No.	Description
050	- exhaust gas temperature after catalyst
066	- lambda actual value
071	- power reduction, high exhaust gas temperature after engine bank 1
072	- power reduction, high exhaust gas temperature after engine bank 2
073	- pressure emergency cooler circuit
100	- overvoltage line L1
101	- overvoltage line L2
102	- overvoltage line L3
103	- undervoltage line L1
104	- undervoltage line L2
105	- undervoltage line L3
106	- overfrequency line
107	- underfrequency line
108	- Mains monitoring tripped in the cabinet
109	- vector offset skip
112	- overvoltage generator
113	- undervoltage generator
114	- overfrequency generator
115	- underfrequency generator
116	- generator difference current monitoring
118	- error control cabinet
122	- error Bus to the control system
123	- emergency stop signal
124	- error safety chain
125	- generator switch tripped
126	- power switch tripped
127	- failure ignition
129	- error gas mixer line 1
131	- failure auxiliary systems
133	- error heat dump
143	- gas pressure line 1 min
144	- gas pressure line 1 max
145	- gas density line 1
151	- gas detector unit pre gas alarm
152	- gas detector unit main gas alarm
153	- fire alarm system
171	- safety pressure limiter min.
172	- safety pressure limiter 1 max
173	- safety pressure limiter 2 max
174	- safety temperature limiter 1 max
175	- safety temperature limiter 2 max
177	- service hours exceeded warning
178	- service hours exceeded stop
180	- false start
181	- connection time generator contactor exceeded
185	- lambda controller fault
191	- NSM relay enable missing
192	- NSM relay power reduction stage 1
193	- NSM relay power reduction stage 2
194	- stop by NSM relay
195	- message stop remote services
196	- message stop by remote services
197	- message stop by remote services
198	- warning test program is active

15.3. Gas Leaks

- Detectable by an acrid smell
- On a containerised CHP the gas detection alarm will sound
- Close the main gas valve
- Ventilate the plant room and inform the Site Manager
- Do not operate any electrical switchgear
- Inform Hoval Service

15.4. Oil Leaks

- Shut down the CHP plant
- Close the valve to the automatic oil refill tank
- Soak up any leaked oil and dispose of it in accordance to local environmental regulations
- Inform Hoval Service

15.4. Heating Circuit Leaks

- Shut down the CHP plant and close the incoming isolation valves
- Soak up any leaked water and dispose of it in accordance to the local environmental regulations
- Inform Hoval Service

15.6. Exhaust Gas Leaks

- Detectable by a smell of exhaust gas
- Close the main gas valve
- Ventilate the plant room and inform the Site Manager
- Do not operate any electrical switchgear
- Inform Hoval Service

Please refer to the Safety Information as detailed on pages 5 and 6 of this manual.

Notes



One-stop shopping

With us you can easily incorporate gas, oil, heat pump, solar, CHP, or biomass energy solutions into your heating system.

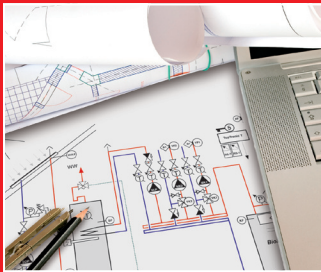

Technical advice

We are happy to assist you and your planning partners in developing intelligent systems, allowing you to take advantage of our expertise and the experience of our specialists.



After sales

For specialist commissioning and maintenance of your Hoval equipment, contact our service and spares department.

Hoval Ltd
Northgate
Newark-on-Trent
Nottinghamshire
NG24 1JN
United Kingdom

Phone 01636 672 711
Fax 01636 673 532
email boilersales@hoval.co.uk
www.hoval.co.uk

MARCH 2013

Responsibility for energy and environment

Hoval follows a policy of continued improvement and reserves the right to change specifications without notice.

Hoval