

BioLyt (8-36)

Wood pellet boiler



United Kingdom

Hoval Ltd.
Northgate
Newark
Nottinghamshire NG24 1JN
Phone +44 1636 67 27 11
Fax +44 1636 67 35 32

Export

Hoval Aktiengesellschaft
Austrasse 70
9490 Vaduz
Principality of Liechtenstein
Phone +423 399 24 00
Fax +423 399 24 11

1.	Information about your heating system	4
1.1	Fuel quality / pellet delivery	4
1.1.1	Fuel quality	4
1.1.2	Pellet delivery	4
1.2	Important addresses and telephone numbers.....	4
1.3	BioLyt (8-36) wood pellet boiler	4
2.	Important notes	5
2.1	Key to symbols used	5
2.2	Safety instructions	5
2.3	Entering the pellet storage room, storage tank	5
2.4	Cautionary notes	6
3.	Functional principle of the heating system	7
3.1	What happens inside the BioLyt?	9
3.2	How does the automatic pellet feed (Option) from the storage room work?	10
4.	Heating system control	11
4.1	What is the function of the boiler controller TopTronic® T?	11
4.2	How you can save energy	11
4.3	Basic display	11
4.4	Operating and display elements	12
4.4.1	Function of the operating elements	12
4.4.2	Basic procedure for changing settings.....	12
4.4.3	What to do if	13
4.4.4	The operating elements on the boiler control panel	14
4.5	Main settings	16
4.5.1	Changing the room temperature	16
4.5.1.1	Setting the desired room temperature, day	16
4.5.1.2	Setting the desired reduced (night-time) temperature.....	17
4.6	Operating modes	18
4.6.1	Function of the operating modes	18
4.6.2	Operating modes for holiday and absence?.....	19
4.6.3	Changing the operating mode - for "HOLIDAY TIL," "ABSENT TIL" and "PARTY TIL."	20
4.6.4	Changing the operating mode - for "AUTOMATIC," "SUMMER," "HEATING," "RED. HEATING" and "STANDBY"	21
4.7	Switching times (heating times)	22
4.7.1	Standard heating times	22
4.7.2	Table for recording individual switching times.....	22
4.7.3	Changing the switching times (heating times).....	23
4.7.4	Copying switching times.....	26
4.8	Heating curve.....	28
4.8.1	Heating curve (heating characteristic curve).....	28
4.8.2	Changing the heating curve (heating characteristic curve).....	29
4.9	Domestic hot water.....	30
4.9.1	Setting the domestic hot water temperature	30
4.9.2	Manual DHW re-charging	31
4.9.3	Domestic hot water economy temperature (reduced temperature).....	32
4.10	Further settings	34
4.10.1	Setting the clock	34
4.10.2	Setting the date.....	35
4.10.3	Changing between summer and winter time	35
4.10.4	Setting the language	36
4.10.5	Reloading the standard switching times program - Deleting your own time program	37
4.10.6	Manual operation	39

4.11 System information40

4.11.1 Information key for system temperatures and heating circuit information40

4.11.2 Information on the boiler status41

4.11.3 Displaying and resetting the consumption meters and cleaning messages43

4.11.4 Changing off-periods for the extraction system46

4.11.5 Special symbols49

4.11.6 Maintenance message49

4.11.7 Optional accessories50

5. Fault repair 51

5.1 Blocking switch and reset button51

5.2 Display of heating regulator alarms51

5.3 Display of boiler controller alarms51

5.4 Overview of alarms, heating regulator TopTronic®T52

5.5 Overview of alarms, boiler controller54

5.6 Checklist in case of faults55

6. Checking the water level 56

7. Commissioning 56

8. Maintenance 57

8.1 Cleaning the ash box57

8.1.1 Empty the ash box57

8.1.2 Removing the ash box57

8.1.3 Fitting the ash box58

8.1.4 Resetting the special display "W:40"58

8.2 Annual maintenance or major maintenance59

8.2.1 Preparation59

8.2.2 Cleaning the flue gas collector59

8.2.3 Cleaning the flue gas sensors60

8.2.4 Cleaning/ checking the post-combustion ring and dust separator60

8.2.5 Cleaning the combustion chamber, burner and ignition tube61

8.2.6 Cleaning/ checking the burner mechanism62

8.2.7 Cleaning/checking the pellet hopper and suction module (if present)62

8.2.8 Further information62

8.3 Cleaning / checking the storage room62

9. How you can save energy 63

10. Instructions concerning proper disposal of individual system components 63

1. Information about your heating system

Dear heating system owner,
 With the purchase of this Hoval BioLyt (8-36) wood pellet boiler, you have made an excellent choice. It offers you all the advantages of a modern and efficient heating system.

Please read these instructions carefully. They describe how the boiler works, how it is operated and serviced.

Further information can be obtained from our Sales and Service Centres. (See last page for contact details).

1.1 Fuel quality / pellet delivery

1.1.1 Fuel quality

The BioLyt (8-36) wood pellet boiler has been designed for optimum combustion of wood pellets. The pellets must meet the requirements of at least one of the standards listed below

- ÖNORM M 7135
- DIN 51731 / HP5 (DINplus)
- SN 166000
- EN 14961-2 / A1 (ENplus/A1)

Hoval recommends ENplus (Class A1):



1.1.2 Pellet delivery

- Do not fill the storage room until after initial commissioning of the boiler.
- Switch off the heating system as instructed 15 min. before filling the storage room.
- To measure pellet consumption since the last delivery, reset the counter "USAGE 1." You can measure consumption over a specific period of time (e.g. annual consumption) by always resetting the counter on a specific date (e.g. January 1). For further information, see Chapter 4.11.3.

1.2 Important addresses and telephone numbers

Heating engineer _____

Plumber _____

Electrician _____

Master chimney sweep _____

1.3 BioLyt (8-36) wood pellet boiler

To be completed by the heating engineer:

Order No. / Manufacturing No.: _____

Boiler type: _____

Nominal boiler output: _____ kW

Hot water buffer storage tank size (if present): _____

Calorifier size: _____

Heating pump type: _____

Heating regulator type: _____

Mixing valves type: _____

Calculation basis for heating system

Lowest outside temperature: _____ °C

Energy demand: _____ kW

Max. flow temperature: _____ °C

2. Important notes

2.1 Key to symbols used

Please pay particular attention to the following symbols used in this operating manual.

- 

Failure to observe instructions to this effect can lead to danger to persons.
- 

Failure to observe instructions to this effect can lead to malfunctions or damage to the boiler or the heating system.
- 

The marked sections of text contain information and tips on operating and running the system.

2.2 Safety instructions

(Information for the protection of persons)



- **Caution**
Switch off the heating system as instructed 15 min. before filling the storage room.

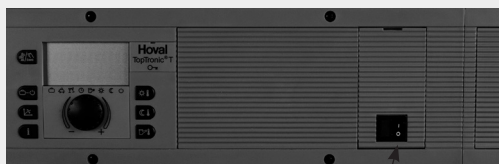

Press the blocking switch.

- **Keep the air supply to the boiler room open:**
Air inlets and outlets must not be closed. It is important to ensure that the combustion air required for correct operation of the boiler can flow unhindered in order to protect operating personnel from an oxygen-depleted atmosphere.
- **Do not operate the boiler with the doors or pellet hopper open (danger of burn-back).** In addition, any sparks emitted from the boiler could cause a fire.
- **Regular cleaning must be performed; otherwise, any possible warranty claims will become invalid.**
- **Parents must keep children away from the boiler room; the heating system is not a toy!**

- **Unsuitable fuel must not be burned (see Chapter 1.1); otherwise, any possible warranty claims will become invalid.**
- **Do not carry out any modifications to the unit (danger to persons; loss of any possible warranty claims).**

2.3 Entering the pellet storage room, storage tank

Under unfavourable circumstances, an increased concentration of harmful gases (such as carbon monoxide) may occur in pellet storage rooms, possibly posing a risk when accumulating over a longer period of time. Despite the fact that under normal circumstances, there is no risk at all, the possibility of such a scenario cannot be ruled out.

- If work is being carried out in filled storage rooms, a second person must always be present outside the room for safety reasons.
- The pellet storage room must always be thoroughly aerated before anyone enters it.
The storage room must be ventilated for at least 15 minutes. In the case of pellet storage rooms with a volume of more than 10 t, the duration of ventilation must be extended or mechanical ventilation provided.
- No-one should enter the storage room in the four weeks following filling. If it is necessary for persons to enter the storage room, the room must be ventilated for at least 2 hours before entering.
- It must be ensured that the storage room door remains open while there are persons inside the storage room.
- Entering fuel storage rooms that have not been aerated (particularly underground tanks) must be avoided, and only trained personnel is permitted to do so. Before entering the room or tank, the concentration of CO must be measured (the concentration must be less than 30 ppm). If necessary, thoroughly aerate the storage room or tank before entering it.
- If the storage area is difficult to access or if it is accessible only from above (as in the case of underground tanks), the person entering the tank must be additionally secured.
- Keep children away from the pellet storage area!

- If there are moving parts (worm conveyors) in the storage room, turn off the mains switch of the heating system before entering the storage room, as otherwise there is a risk of injury.
- Smoking, naked flames and other possible sources of ignition are prohibited inside the storage room.

2.4 Cautionary notes

(Information on the protection of the heating system)

Checking the water level

Check the water level in the system at regular intervals (see Chapter 6).

Filling the heating system

The heating system can normally be filled and topped up with mains water. No chemical additives should be added to the water. The water quality can vary greatly in different parts of the country (you can obtain information about the water quality from your local water company), and it might not always be suitable for filling the heating system (highly corrosive or very hard water).

Please contact your heating engineer in such cases (see also Technical Information).

Circulation pumps

During the periods when no heating is required, the circulation pumps should be operated for approx. 2 minutes at least once every month. This will prevent the pumps from seizing up.

Leak-tightness / Backfire protection

The doors and pellet hopper must be checked for leaks on an annual basis. Smoke leaks should be avoided in order to prevent any toxic low-temperature gases from escaping into the boiler room.

Operation and cleaning

Periodic cleaning and inspection by the heating engineer or Hoval customer service will not only extend the service life of the pellet boiler, but also increase its operating safety and ensure that a high combustion efficiency is maintained.

Pellet storage rooms must be cleaned regularly (approx. every 2-3 years), and the sawdust which has accumulated must be disposed of!

Protecting the boiler

Do not use sprays, solvents, chlorine-based cleaning products, paint, adhesives etc. in the proximity of the boiler. These substances can cause corrosion inside the boiler and the flue gas system.

Overpressure safety valve, backfire protection and thermal discharge safety device

Periodically, a heating engineer must check the proper functioning of the safety equipment (overpressure safety valve, backfire protection on the burner).

The heating installation must be inspected regularly according to local regulations.

3. Functional principle of the heating system

It is important that the perfectly coordinated individual components function properly to ensure that your home stays warm in winter.



COMPONENTS
Wood pellet boiler

FUNCTION:
Burns the pellets safely and in an environmentally friendly manner..
Extracts the heat from the combustion gases and transfers it to the heating water.



Pellets

The process of combustion within the boiler converts the natural energy contained in the pellets into heat.



Optional heating water buffer storage tank

Is used for intermediate storage of hot **heating water** (max. 80°C). It thus compensates for any differences between heat generation and demand.



Storage tank calorifier

Holds a reserve of **domestic hot water** for household consumption (e.g. for showering).



Boiler controller with heating regulator

Controls and monitors the operation of the boiler. Maintains the desired room temperature optimally and fuel-efficiently, independent of the outside temperature.



Radiators, underfloor heating, if fitted

Releases the heat of the heating water into the room.



Heating pump

Transports the heating water from the boiler to the radiators and back into the boiler, where it is reheated.



Heating water and heating pipes

Transports the heat which is generated from the boiler to the radiators.





Mixing valve

Adjusts the heating flow temperature to the radiator to maintain the desired room temperature whatever the outside temperature. This is achieved by mixing in colder return heating water.



Pressure gauge

Displays the water pressure in the heating system.



Air vent

Ensures that the heating pipes contain only heating water and no air.



Safety valve

Prevents overpressure in the system.



Membrane expansion tank

Maintains the pressure in the system at a constant level and absorbs the expansion water.

Depending on the type of heating system selected, some of the components might not be present or others added. The heating engineer will explain the system to you.

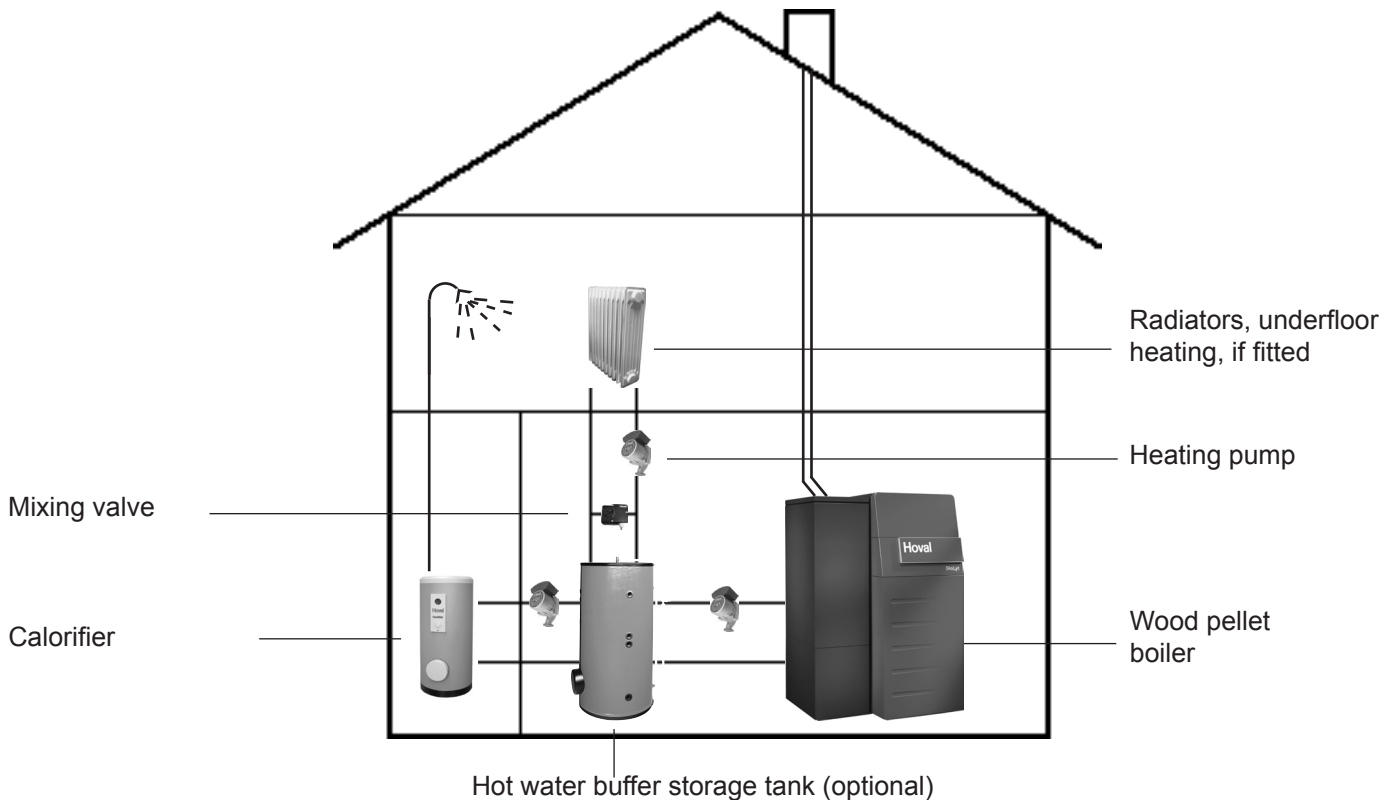

3.1 What happens inside the BioLyt?

The BioLyt has been designed for the low-emission combustion of wood pellets in accordance with ÖNORM M 7135 and DIN 51731, HP5 (/ DINplus) and EN 14961-2, A1 / ENplus. The core element of the BioLyt is a rugged horizontal burner tube, which provides a stable fire bed with its large, plate-shaped burner. The post-combustion ring and dust separator above the burner plate give it a distinct design. By combining these features, the burner is able to keep dust emissions to a minimum. This is yet another eco-friendly feature, since it burns with practically no ash residues and provides for stable operation even with variable pellet quality.

The BioLyt features a standard pellet hopper and an optional fully-automated pellet feed system. When the integrated pellet hopper is used exclusively, it needs to be refilled manually. When combined with the pellet feed system, the pellet hopper is filled automatically from a store. This feeder unit with control system and suction turbine transports the pellets through a flexible tube from the storage room directly to the hopper. The hopper is filled within minutes on a time-controlled and as-needed basis, which is usually twice a day.

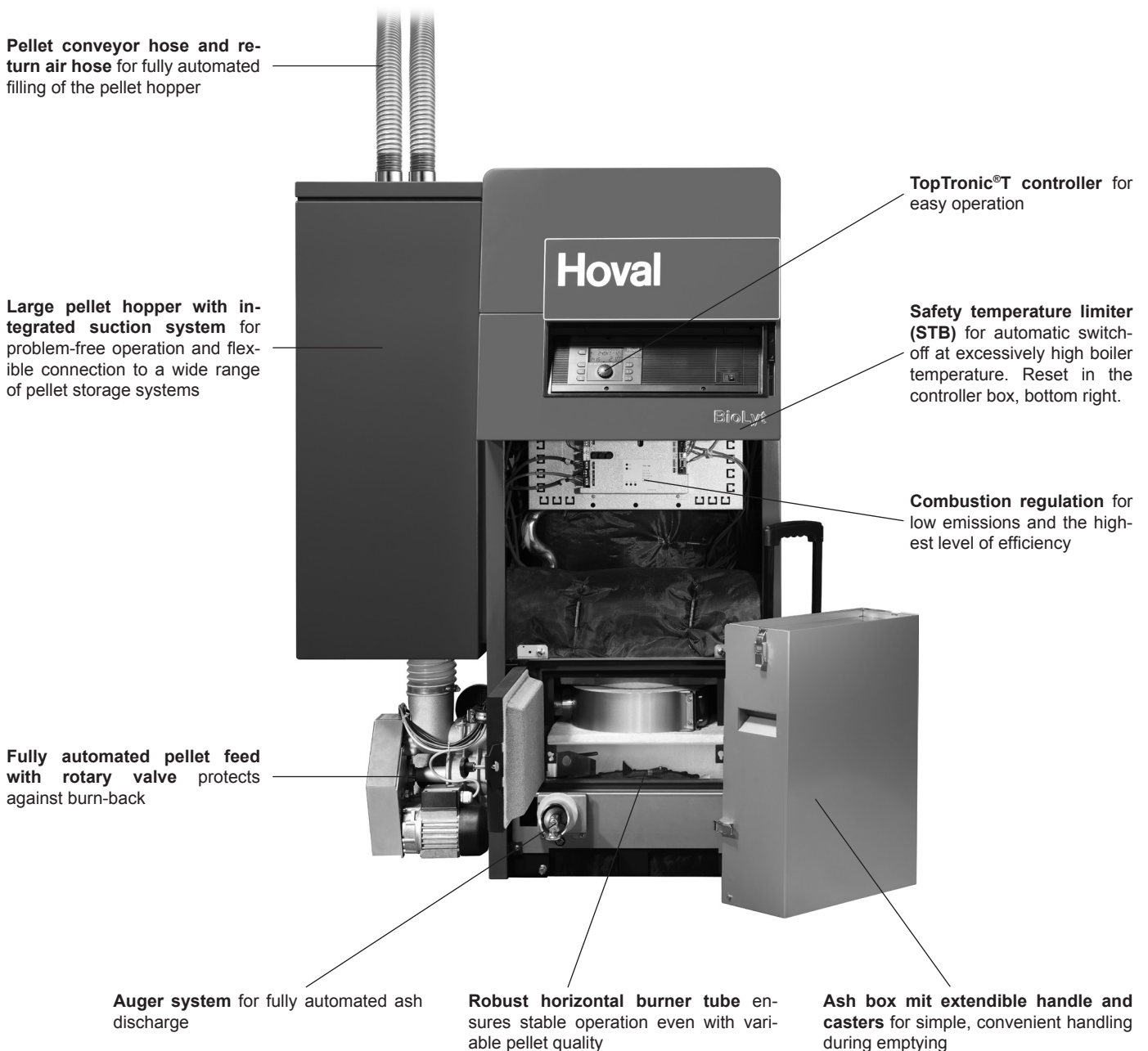

3.2 How does the automatic pellet feed (Option) from the storage room work?

The pellets are extracted from the storage room either directly via suction probes (Fig. 01), a mole system or by means of a worm conveyor and then transported to the pellet hopper on the boiler by means of a vacuum turbine.

The pellet hopper on the boiler includes two filling level indicators:

- for the signal "pellet hopper full" / top
- for the signal "pellet hopper empty" / bottom on the burner

The pellet hopper can only be filled during the preset enable time in order to minimise the noise in the building.

The filling process is started every time the burner enters burn-out mode or, at the latest, when the bottom filling level indicator signals "empty."

First, the suction turbine starts up.

Then, the mole (if fitted) or the discharge screw starts operating after a delay of approx. 15 secs.

Discharge is stopped as soon as the upper filling level indicator sends the signal for "pellet hopper full." If a mole or a discharge screw are fitted, the suction turbine runs on for a time in order to flush the hoses.

The extraction system can be disabled during two periods of time per day (e.g. to avoid unwelcome noise during the night). The factory settings are from 12.30 p.m. to 15.30 p.m. and from 22.00 p.m. to 07.00 a.m. To ensure that there is an adequate supply of pellets to span such off-periods, forced burn-out with filling of the pellet hopper is carried out 30 min. before the beginning of every off-period. Off-periods can be deactivated by setting the beginning and end of the respective period to 00.00 (see Chapter 4.11.4).

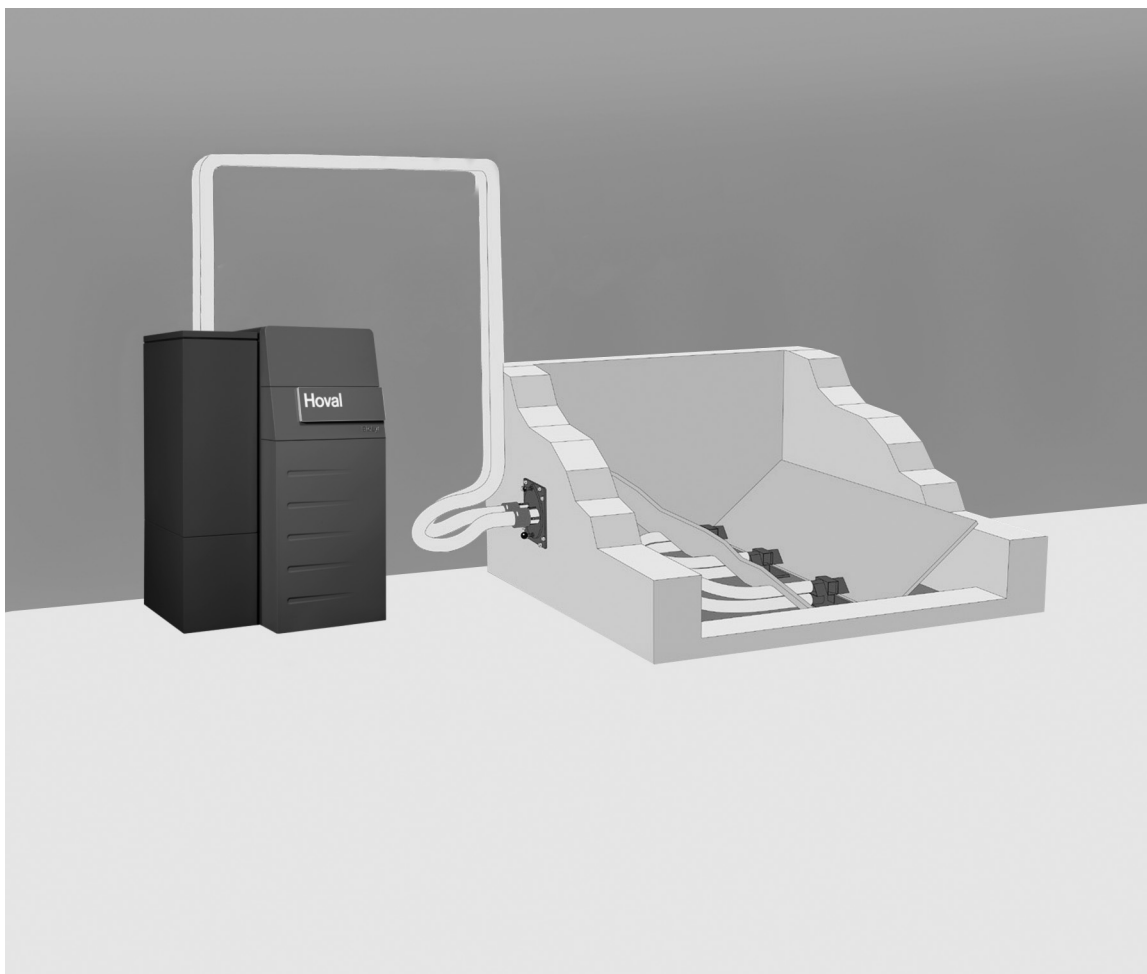

Fig. 01

4. Heating system control

4.1 What is the function of the boiler controller TopTronic® T?



The boiler controller, together with the temperature sensors connected to it, is, so to speak, the brain of the heating system. Its main functions are:

- maintaining the desired room temperature independent of the outside temperature
 - heating the living space only when required
 - producing warm water (e.g. for showering) only when required
 - displaying information
- further functions:
- input of desired temperatures and operating modes
 - turning the heat generator ON/OFF
 - monitoring temperatures

The correct settings for the heating system have already been applied by Hoval, or the heating engineer, during commissioning. Any changes to those settings should only be carried out if you go away on a trip or if your home is too cold or too warm. You can find an overview of the most frequently asked questions and the answers to them in Chapter 4.4.3.

4.2 How you can save energy



For your benefit and for the environment, use energy efficiently and avoid unnecessary losses:

With little effort, you can optimise the operation of your system and make it worth while.

It is worth turning the heating off again during spells of warm weather in autumn to prevent your heating system generating unnecessary heat when outside temperatures are low in the morning and thus overheating your home. Turning the heating on or off depending on the weather conditions is one of the most effective energy-saving measures. If you want to save yourself the effort of going down into the cellar, you may want to consider acquiring a “remote control” from Hoval, which will allow you to operate and control the heating comfortably from your living room.

4.3 Basic display

The basic display shows the day of the week, date and time, as well as the current heat generator temperature or another temperature (system-dependent).

4.4 Operating and display elements

4.4.1 Function of the operating elements

The central push & turn button and the labelled keys are designed for easy and straightforward operation.

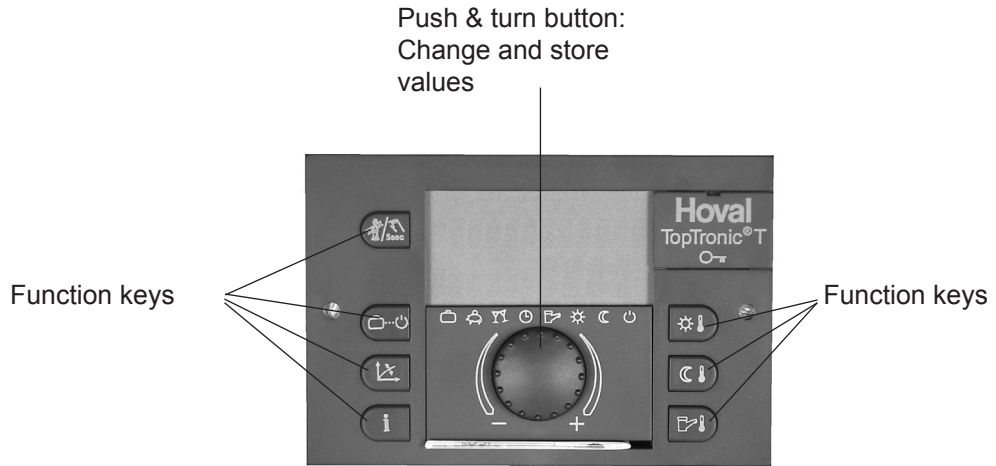





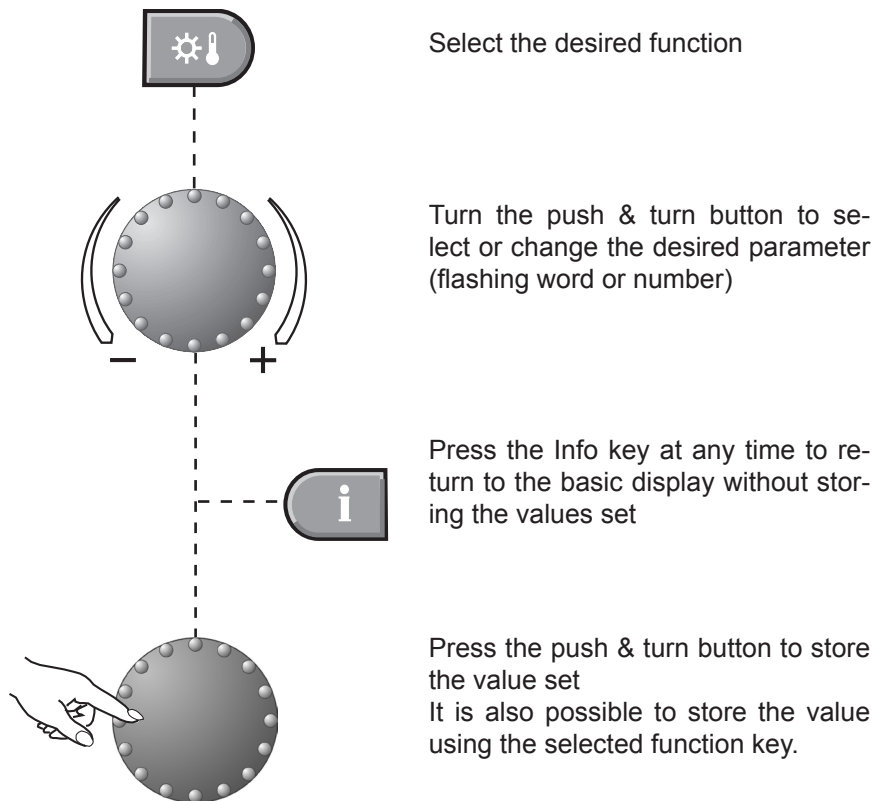





4.4.2 Basic procedure for changing settings

An example









4.4.3 What to do if ...

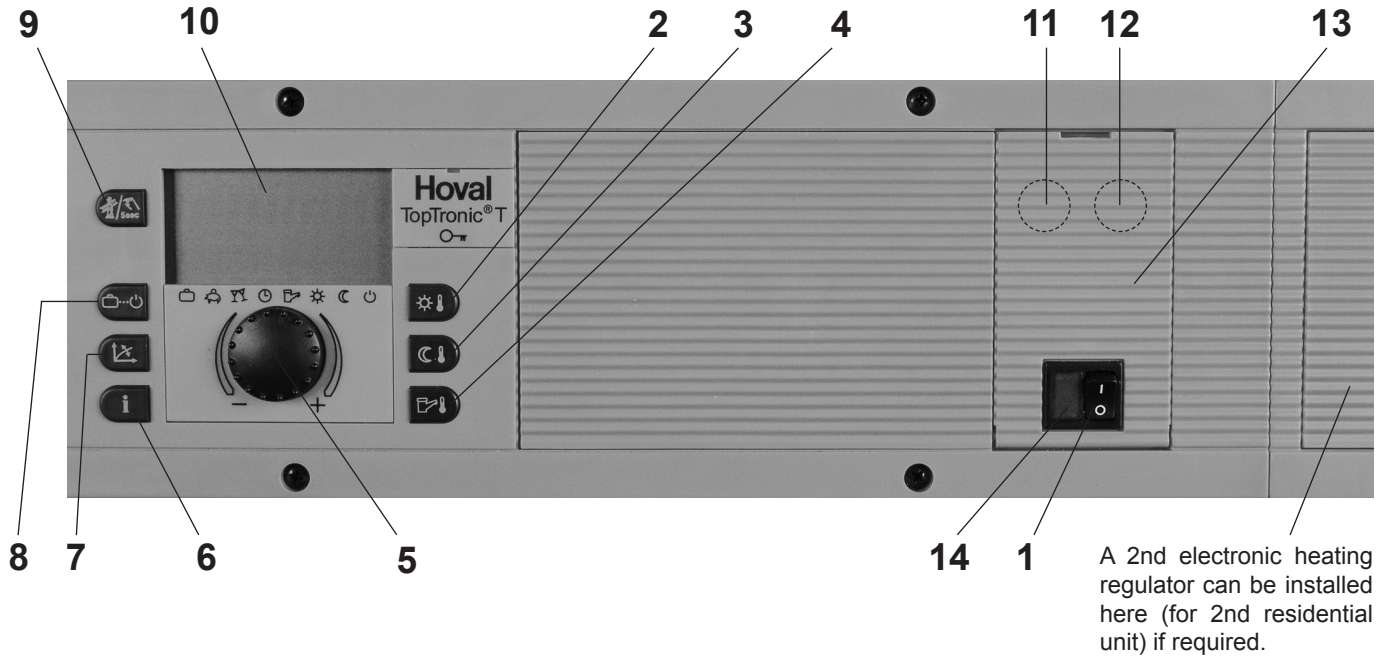





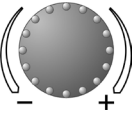





The following information can be used as a first level support in frequently occurring situations.

Observation	Remedy
It is too cold	Set higher values for the room temperature with  and the rotary button (Chapter 4.5.1).
It is too warm	Set lower values for the room temperature with  and the rotary button (Chapter 4.5.1).
From now on, equal day and night temperatures should be maintained continuously	Use  to set the operating mode to ☀ "HEATING" (Chapter 4.6.1, 4.6.4).
This evening, I want the heating to remain on for longer	Use  to set the operating mode to 🎉 "PARTY" and set the desired time (Chapter 4.6.1, 4.6.3).
I require a larger amount of hot water at the moment	 Press for 3 seconds and set the additional re-charging time (Chapter 4.9.2).
From now on, hot water but no heating is required	Use  to set the operating mode to ☀ "SUMMER" (heating off, hot water only) (Chapter 4.6.1, 4.6.4).
Suddenly, there is no heating or hot water; it is cold.	Check the heating regulator and boiler controller for alarms (Chapter 5.2, 5.3) and consult a heating engineer if necessary.
The room temperature setpoint requires frequent adjustments because it is too cold or too hot	Change the set heating curve (Chapter 4.8.2). Changing the heating curve does not make sense if your system is fitted with a room air sensor (or room station) and an outside sensor. The correct settings for the heating curve are then provided automatically. Consult a heating engineer if necessary.
I will be absent for several hours during the day today	Use  to set the operating mode to 👤 "ABSENT TIL" and set the time of your return (Chapter 4.6.1 - 4.6.3).
I am going away on a short trip (e.g. 3 days)	Use  to set the operating mode to 🗓️ "HOLIDAY TIL" and set the date of your return (Chapter 4.6.1 - 4.6.3).
I am going away for an indefinite period of time	Use  to set the operating mode to 🌙 "RED. HEATING." When you return, use  to set to 🕒 "AUTOMATIC" (Chapter 4.6.1, 4.6.2, 4.6.4).
In summer, it is too cold or too warm.	Indicates that the summer disconnection is active. If it is too cold for you, use  to set operating mode ☀ "HEATING" (Chapter 4.6.1, 4.6.4).

4.4.4 The operating elements on the boiler control panel



Key	Designation	Function
1	 Blocking switch	Switch off and block the boiler (e.g for cleaning).
2	 Daytime room temperature	Set the daytime room temperature. Chap. 4.5.1.1
3	 Reduced room temperature	Set the night-time room temperature (reduced heating). Chap. 4.5.1.2
4	 Domestic hot water temperature	Set the domestic hot water temperature. Manual DHW re-charging. Chap. 4.9.1, 4.9.2
5	 Push & turn button	Set the values by turning. Acknowledge the values by pressing. Select functions by pressing and turning.
6	 Information key	<ul style="list-style-type: none"> Show operating data on the display Return to the basic display without saving the values. Ex. 4.11.1
7	 Heating curve setting	Set the heating curve Chap. 4.8.2

Key	Designation	Function
8		<p>Operating mode selection key</p> <p>Select the operating modes</p>
	<ul style="list-style-type: none">  Holiday  Absence  Party  Automatic  Summer  Heating  Reduced heating  Standby 	<ul style="list-style-type: none"> Turn off the heating system while you are on holiday (frost protection) Chap. 4.6.1 - 4.6.3 Switch off the heating temporarily Chap. 4.6.1 - 4.6.3 Extend heating operation Chap. 4.6.1 - 4.6.3 Automatic heating according to the preset heating times = normal heating operation Chap. 4.6.1, 4.6.4 only DHW; Heating Off Chap. 4.6.1, 4.6.4 Constant heating mode Chap. 4.6.1, 4.6.4 Constant reduced heating operation Chap. 4.6.1, 4.6.2, 4.6.4 System Off - frost protection active Chap. 4.6.1, 4.6.2, 4.6.4
9		<p>Manual mode / emission measurement</p> <p>For heating engineer only or for preliminary acknowledgment of a maintenance prompt (see Chapter 4.11.6).</p>
10		<p>Display</p> <p>The basic display shows the day of the week, date and time, as well as the current heat generator temperature or another temperature (system-dependent).</p>  <p>Possible readouts:</p> <ul style="list-style-type: none"> 1 Active heating time 24h 2 Day display 3 Display of the active operating state and the clock program 4 Time 5 Selected operating mode 6 Date / Day / Month / Year 7 Heat generator temperature or another temperature (system-dependent)
11	Control panel fuse, under the hinged cover	Check the 6.3 A fuse if all displays remain dark. This may only be done by the heating engineer!
12	Reset button, under the hinged cover	If the display shows "Error," press the Reset button under the hinged cover. If this happens frequently, notify your Customer Service centre.
13	Brief operating instructions in the hinged cover	Special brief operating instructions are provided with the boiler controller.
14	Burner fault light	Press the Reset button (see no. 12)

4.5 Main settings

4.5.1 Changing the room temperature

4.5.1.1 Setting the desired room temperature, day

i These adjustments can also be carried out on a room station.

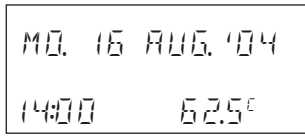

Start - Basic display

1



➔ Tap the "Daytime room temperature" key.

2

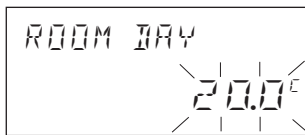

i The daytime room temperature setpoint flashes.

3

i If "MC1" is shown on the display, you need to select the heating circuit. (Information on which heating circuit to select for your home can be found on page 4 of these instructions).

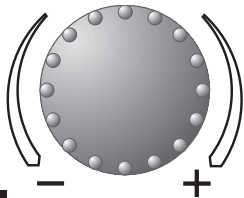

➔ Set the desired room temperature by turning the "push & turn button."

4

i Setting range 5 - 30°C (Factory setting 20°C)

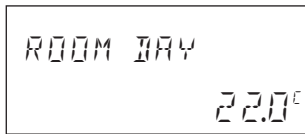

i The new "Daytime room temperature" setpoint appears on the display.

5



➔ Tap the "Daytime room temperature" key to acknowledge the temperature setpoint.

6

4.5.1.2 Setting the desired reduced (night-time) temperature

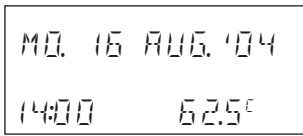

Start - Basic display

1

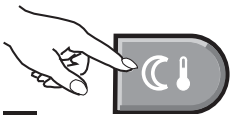

⇒ Tap the “Reduced room temperature” key.

2

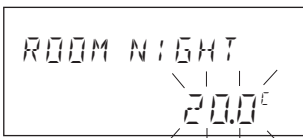

The night-time room temperature setpoint flashes.

If “MC1” is shown on the display, you need to select the heating circuit.

3

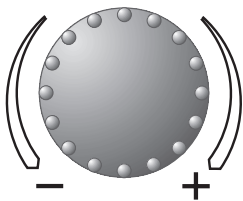

⇒ Set the desired room temperature by turning the “push & turn button.”

Setting range 5 - 30°C (Factory setting 16°C)

4

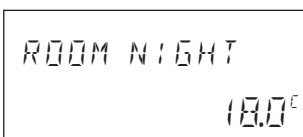

The new “Reduced room temperature” setpoint appears on the display.

5















⇒ Tap the “Reduced room temperature” key to acknowledge the temperature setpoint.

6

4.6 Operating modes





4.6.1 Function of the operating modes

Operating mode	Function	Application						
HOLIDAY 	<ul style="list-style-type: none"> - Heating system off while you are on holiday. - Room temperature set to minimum (10°C). - Calorifier frost protected (5 °C). 	<p>You are going on holiday for e.g. 1 week and you know the date of your return.</p> <p>Chap. 4.6.2, 4.6.3</p>						
<p>(i) End of holiday = Return date. Normal heating is resumed on the day of your return! Setting range: current date + 250 days. To switch back to automatic mode prematurely - press the "operating mode selection key"  for 3 seconds.</p>								
ABSENT 	<ul style="list-style-type: none"> - Heating system OFF (heating temporarily switched off until set time). - Room temperature set to minimum (10°C). - Calorifier frost protected (5 °C). 	<p>You leave home in the morning and come back in the evening.</p> <p>Chap. 4.6.2, 4.6.3</p>						
<p>(i) Setting range: 0.5 - 24 h. To switch back to automatic mode prematurely - press the "operating mode selection key"  for 3 seconds.</p>								
PARTY 	<ul style="list-style-type: none"> - Extend heating (daytime room temperature) up to set day/night time (you do not want to reduce the room temperature at the preset time). 	<p>You have guests in the evening.</p> <p>Chap. 4.6.3</p>						
<p>(i) Setting range: 0.5 - 24 h. To switch back to automatic mode prematurely - press the "operating mode selection key"  for 3 seconds.</p>								
AUTOMATIC 	<ul style="list-style-type: none"> - Automatic heating mode according to the heating times set in the 1st switching times program = normal heating mode. 	<p>You want to heat as cost effectively and efficiently as possible.</p> <p>Chap. 4.6.4</p>						
<p>(i) Factory setting:</p> <table border="0"> <tr> <td>Heating:</td> <td>06.00 - 22.00</td> </tr> <tr> <td>Reduced heating mode:</td> <td>22.00 - 06.00</td> </tr> <tr> <td>Domestic hot water:</td> <td>05.00 - 22.00</td> </tr> </table>			Heating:	06.00 - 22.00	Reduced heating mode:	22.00 - 06.00	Domestic hot water:	05.00 - 22.00
Heating:	06.00 - 22.00							
Reduced heating mode:	22.00 - 06.00							
Domestic hot water:	05.00 - 22.00							
SUMMER 	<ul style="list-style-type: none"> - Heating system OFF - DHW is produced at the times set in the switching times program (for showering, etc.) - Frost protection active. 	<p>Heating the rooms is unnecessary due to the high outside temperatures.</p> <p>Chap. 4.6.4</p>						
<p>(i) Factory setting for domestic hot water: 05.00 - 22.00 Operating mode "Summer" cannot be selected if each heating circuit is adjusted separately.</p>								
HEATING 	<ul style="list-style-type: none"> - The room temperature is not reduced during the night. - The rooms are continuously heated at the set "daytime room temperature" . - DHW mode according to switching program. 	<p>You would like to heat the rooms during the night, too.</p> <p>Chap. 4.6.4</p>						
REDUCED 	<ul style="list-style-type: none"> - The rooms are continuously heated at the "Reduced room temperature." . - Continuous reduced heating mode. 	<p>You are going away for an indefinite period of time.</p> <p>Chap. 4.6.2, 4.6.4</p>						
STANDBY 	<ul style="list-style-type: none"> - Heating system OFF. - Frost protection active. - No DHW mode. 	<p>You are travelling for an indefinite period of time in spring or in autumn. It does not matter if the rooms are cold on your return. You do not need warm water on your return.</p> <p>Chap. 4.6.2, 4.6.4</p>						

4.6.2 Operating modes for holiday and absence?

Depending on how long you will be away and what your requirements are with regard to comfort, there are different operating modes available for interrupting or reducing the heating. In any case, you will save a lot of energy and money if the rooms are not heated or heated less during your absence.

The following table is intended as a guide for finding the best operating mode for each particular case:

Application	Operating mode	Function
You are going on holiday for e.g. 1 week and you know the date of your return.	"HOLIDAY TIL"  Heating system and DHW off while you are on holiday.	- Heating system OFF / calorifier frost protected (5°C) - Room temperature set to minimum (10°C) Setting range: from current date to 250 days in the future! End of holiday = Return date. Normal heating is resumed on the day of your return! Early return: Press  for 3 sec. to return to "AUTOMATIC" (Chap. 4.6.1, 4.6.3).
You leave home in the morning and come back in the evening.	"ABSENT TIL"  Heating interrupted temporarily	Heating temporarily interrupted until set time. Setting range: 0.5 - 24 h.
You will be away for an indefinite period of time and want the living area to be at the set reduced temperature on your return.	"RED. HEATING"  Continuous reduced heating mode	Continuous reduced heating and DHW mode (reduced, see Chap. 4.9.3) around the clock.
You will be away for an indefinite period of time during spring or autumn and you don't mind if your home is cool on your return.	"STANDBY"  System off - frost protection active	The entire heating system is switched off and frost-protected!

For a detailed description of how to set the operating modes, see Chap. 4.6.3, 4.6.4.

You can return to the "AUTOMATIC" function (normal heating mode) at any time by "pressing"  for 3 sec.

4.6.3 Changing the operating mode - for "HOLIDAY TIL," "ABSENT TIL" and "PARTY TIL."
 Procedure for activating the operating modes "HOLIDAY TIL," "ABSENT TIL" or "PARTY TIL."

1  Tap the "Operating mode selection" key.

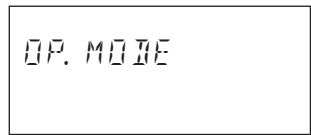
2  "OP. MODE" is displayed briefly.

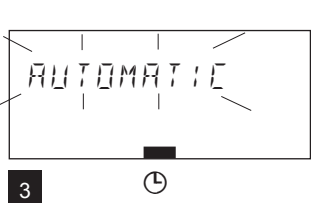
3  The currently active operating mode is then shown flashing on the display.

i A black rectangle in the lower section of the display points to the corresponding symbol!

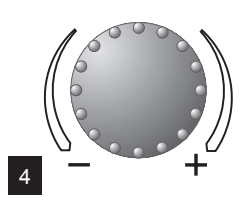
4  Set the desired operating mode by turning the "push & turn button":

i "HOLIDAY TIL," "ABSENT TIL" or "PARTY TIL."

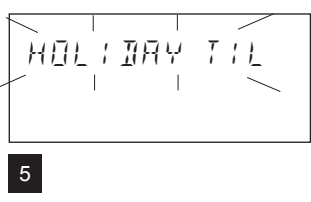
5  The selected operating mode (e.g. "HOLIDAY TIL") is shown flashing on the display.

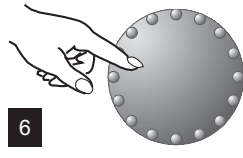
6  Tap the "push & turn button" to acknowledge the selected operating mode.

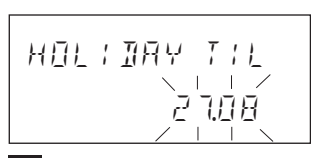
7  Today's date ("HOLIDAY TIL") or the current time ("ABSENT TIL," "PARTY TIL") is shown flashing on the display.

i - for "HOLIDAY TIL," the date on which you return from your holiday.
 - for "ABSENT TIL," the expected time of your return (within max. 24h).
 - for "PARTY TIL," the time the party is expected to end.

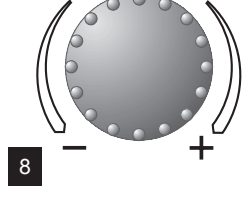
8  Turn the "push & turn button" and select:

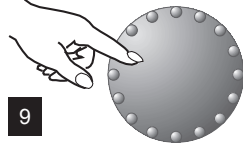
9  Tap the "push & turn button" to acknowledge the setting.

4.6.4 Changing the operating mode - for "AUTOMATIC," "SUMMER," "HEATING," "RED. HEATING" and "STANDBY"

Procedure for activating the operating modes "AUTOMATIC," "SUMMER," "HEATING," "RED. HEATING" and "STANDBY"

⇒ Follow the steps 1 to 3 described in Chapter 4.6.3 "Changing the operating mode"!

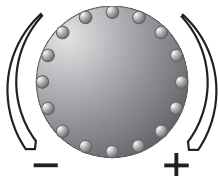

4

⇒ Set the desired operating mode by turning the "push & turn button":

i "AUTOMATIC," "SUMMER," "HEATING," "RED. HEATING" or "STANDBY."



5

The selected operating mode (e.g. "RED. HEATING") is shown flashing on the display.

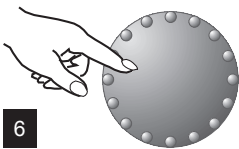

6

⇒ Tap the "push & turn button" to acknowledge the setting.

4.7 Switching times (heating times)

- i** In this menu, you can set individual switching times programs for the heating and DHW modes.
- i** The default heating times preset by the manufacturer are overwritten. However, you can restore the default times easily (see Chapter 4.10.5).
- i** It is possible to program up to 3 heating times per day.
- i** The switching times are only active when the "AUTOMATIC" mode is selected.

4.7.1 Standard heating times

Circuit	Day	Heating from - to
All heating circuits (HC,MC-1,MC-2)	Mo-Su	06.00 - 22.00
Domestic hot water circuit (DHW)	Mo-Su	05.00 - 22.00

4.7.2 Table for recording individual switching times

Switching times program for living area..... (MC1)

Day	Cycle 1		Cycle 2		Cycle 3	
	from	to	from	to	from	to
Mo						
Tu						
We						
Th						
Fr						
Sa						
Su						

Switching times program for living area..... (MC2)

Day	Cycle 1		Cycle 2		Cycle 3	
	from	to	from	to	from	to
Mo						
Tu						
We						
Th						
Fr						
Sa						
Su						

Switching times program for living area..... (HC)

Day	Cycle 1		Cycle 2		Cycle 3	
	from	to	from	to	from	to
Mo						
Tu						
We						
Th						
Fr						
Sa						
Su						

Switching times program for calorifier (DHW)

Day	Cycle 1		Cycle 2		Cycle 3	
	from	to	from	to	from	to
Mo						
Tu						
We						
Th						
Fr						
Sa						
Su						

Further standard programs can be - or may already have been - set up or enabled for programming by the installer (P1-P3) see Page 23.

A maximum of 3 heating times per day are possible, e.g.:



4.7.3 Changing the switching times (heating times)

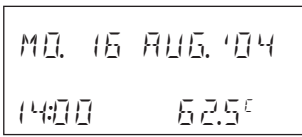

Start - Basic display

1

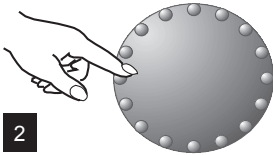

⇒ Press the “push & turn button” for at least 3 sec.

2

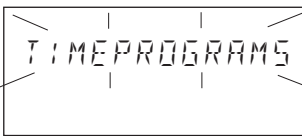

🔊 “TIMEPROGRAMS” is shown flashing on the display.

3

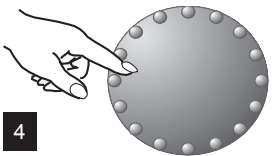

⇒ Tap the “push & turn button” to acknowledge the selected operating mode.

4

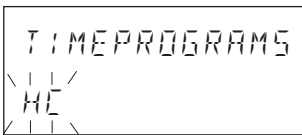

🔊 “HC” is shown flashing on the display

5

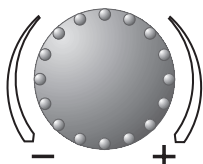

⇒ Select the desired heating circuit by turning the “push & turn button.”

6



e.g.

ⓘ if necessary, select switching time program P1, P2 or P3.

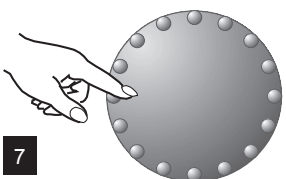

⇒ Tap the “push & turn button” to acknowledge the selected heating circuit.

7

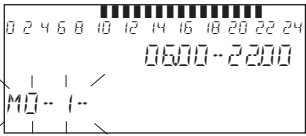

The first day of the week is shown flashing on the display.

Change the flashing value by turning the “push & turn button.” Acknowledge by tapping the “push & turn button.” Go back one step with . Return to the starting point with or automatically after approx. 60 seconds.

8

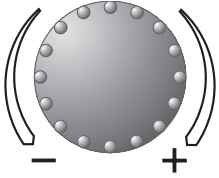

Turn the “push & turn button” until the desired day is displayed.

9

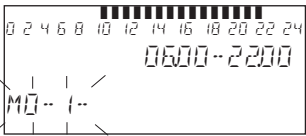

The selected day of the week is shown flashing on the display.

10

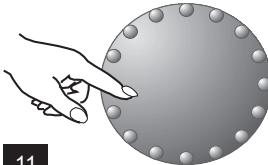

Tap the “push & turn button” to acknowledge the day.

11

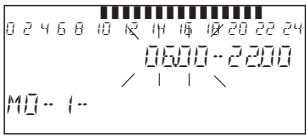

The heating start time is shown flashing on the display.

12

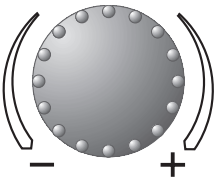

Set the desired heating start time by turning the “push & turn button.”

13

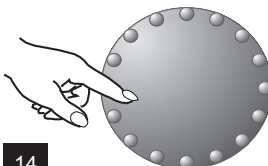

Tap the “push & turn button” to acknowledge the set start time.

14

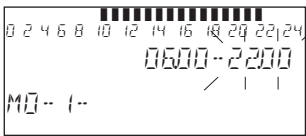

The heating end time is shown flashing on the display.

15

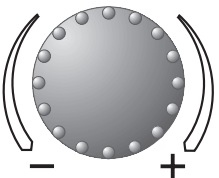

Set the desired heating end time by turning the “push & turn button.”

16

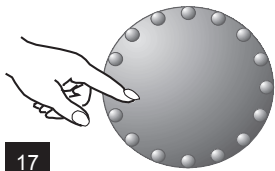

Tap the "push & turn button" to acknowledge the set end time.

17

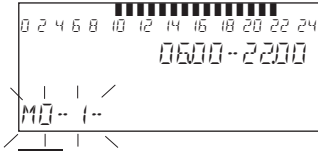

After confirmation of the end time, the day of the week flashes again.

18

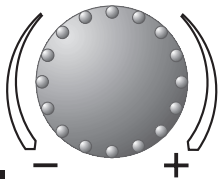

Set a second heating time (Mo -2-) by turning the "push & turn button."

19

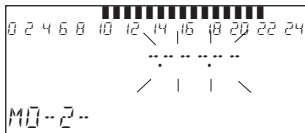

Set the switching times as described for the previous heating circuits.

Keep turning to reach the following day.

20

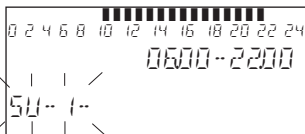

Set the switching times as described for the previous days.

You can also copy the switching times from other days (see Chapter 4.7.4).

21

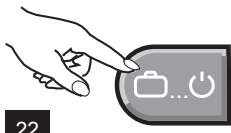

Tap the "Operating mode selection" key to acknowledge the settings.

22

If P1 is displayed, it means that further standard heating time programs are already enabled. If not, P2 and P3 can be enabled by the heating engineer.

Factory setting:
Switching times program P2

Circuit	Day	Heating from
All heating circuits (HC,MC-1,MC-2)	Mo-Th	06.00-08.00 16.00-22.00
	Fr	06.00-08.00 13.00-22.00
	Sa-Su	07.00-23.00
Domestic hot water circuit (DHW)	Mo-Th	05.00-08.00 15.30-22.00
	Fr	05.00-08.00 12.30-22.00
	Sa-Su	06.00-23.00

Factory setting:
Switching times program P3

Circuit	Day	Heating from
All heating circuits (HC,MC-1,MC-2)	Mo-Fr	07.00-18.00
	Sa-Su	reduced
Domestic hot water circuit (DHW)	Mo-Fr	06.00-18.00
	Sa-Su	reduced

4.7.4 Copying switching times

➔ Follow the steps 1 to 8 described in Chapter 4.7.3 “Changing the switching times”!

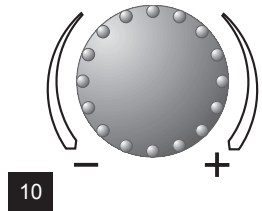

➔ Select “COPY,” “DAY” by turning the “push & turn button.”

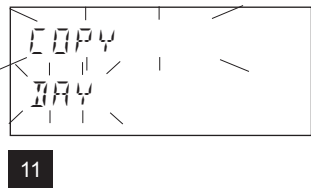

🔗 The settings flash on the display.

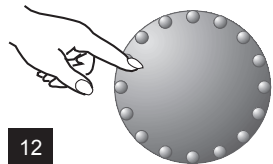

➔ Tap the “push & turn button” to acknowledge the settings.

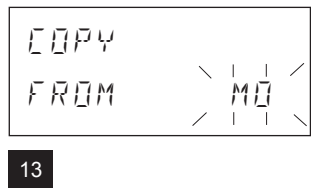

🔗 The selected setting value is shown flashing on the display.

ⓘ Change the flashing value by turning the “push & turn button.”
Acknowledge by tapping the “push & turn button.”
Go back one step with .
Return to the starting point with or, automatically, after approx. 60 sec.

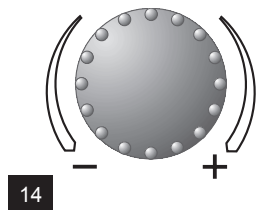

➔ Select the day you want to copy by turning the “push & turn button.”

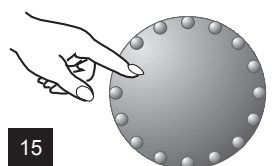

➔ Tap the “push & turn button” to acknowledge the day.

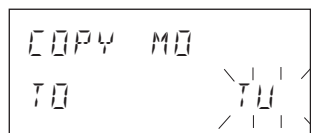

🔗 The target day(s) is (are) shown flashing on the display.

ⓘ Top line = value to copy
Bottom line = target

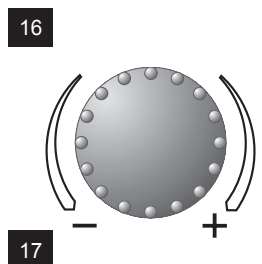

➔ Select the desired value by turning the “push & turn button.”

ⓘ Days: MO, TU....
Whole week: 1 - 7
Workdays: 1 - 5
Weekend: 6 - 7

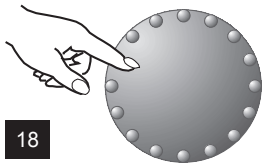

18

⇒ Tap the “push & turn button” briefly to acknowledge the setting.

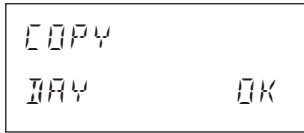

19

👁️ Confirmation for correct copying of day(s).

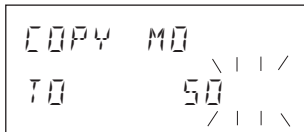

20

👁️ Target range for the next copy process is shown flashing on the display.

ⓘ The same value as in the preceding action is copied to the target range!

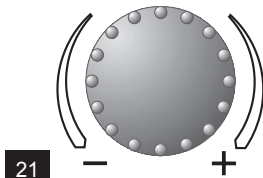

21

⇒ Select the next copy range by turning the “push & turn button.”

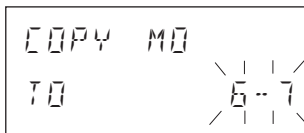

22

👁️ Target range for the copy process is shown again flashing on the display.

ⓘ Follow the same procedure to create any additional copies required.



23

⇒ Tap the “Operating mode selection” key to acknowledge the settings.

ⓘ The start display is shown (basic display).

4.8 Heating curve

4.8.1 Heating curve (heating characteristic curve)

i The heating curve describes the flow temperature of a heating system as a function of the outside temperature.

i The heating curve is preset by the installer *.

i Carry out temporary changes to the room temperature settings via the “Daytime room temperature” or “Reduction temperature.”

i The heating characteristic curve settings should only be changed if the room temperature is not reached over a longer period of time during the heating period.

Recommended settings:

Underfloor heating:	0.3 to 0.8
Radiator heating:	1.0 to 2.0
Convactor heating:	1.4 to 2.0

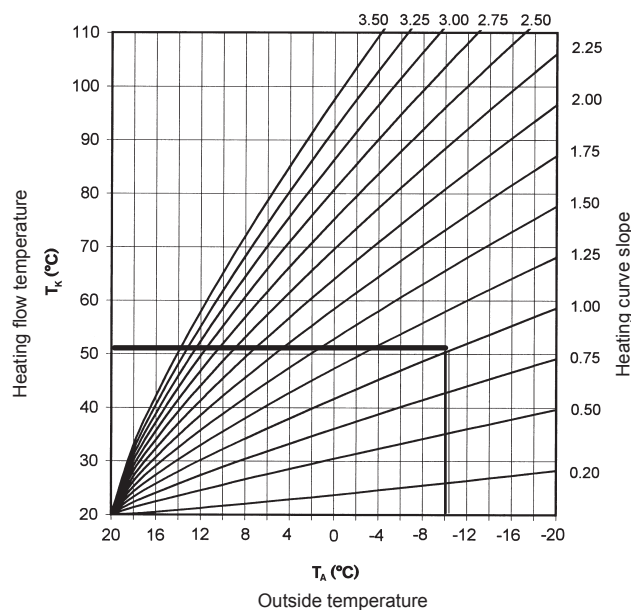

Example:

You have set the system to radiator heating and a heating curve slope of 1.0. At an outside temperature of -10°C , this results in a flow temperature of approx. 52°C if a temperature of 20°C is required.

* Info :

The heating curve for the direct circuit is set to OFF by default. The direct heating circuit is activated automatically by setting a value.

4.8.2 Changing the heating curve (heating characteristic curve)

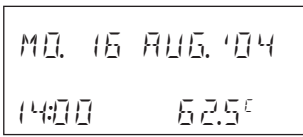

Start - Basic display

1



⇒ Tap the "Heating curve setting" key.

2

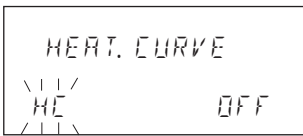

👁️ "Heating curve" - display appears, "HC" flashes

3

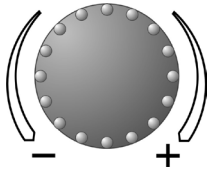

⇒ Select the desired heating circuit by turning the "push & turn button."

4

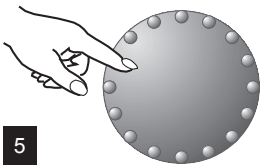

⇒ Tap the "push & turn button" to acknowledge.

5



👁️ The slope of the heating characteristic curve is shown flashing on the display, or OFF if the selected heating circuit is not connected.

6

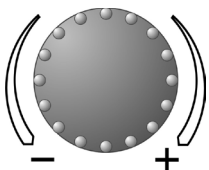

⇒ Select the desired value for the slope of the heating characteristic curve by turning the "push & turn button."

7

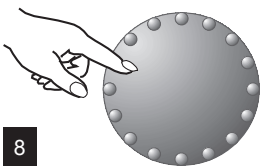

⇒ Tap the "push & turn button" to acknowledge the selected value.

8

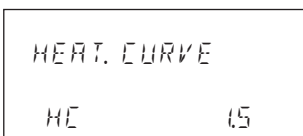

👁️ The selected slope of the heating characteristic curve is shown.

9

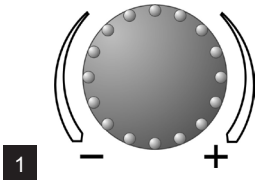

➔ Turn the push & turn button to set further heating circuits...

1

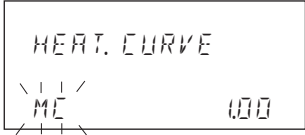

👁️ "Heating curves" appears again on the display. ⓘ For example "MC" (flashing).

2



➔ Tap the "Operating mode selection" key to acknowledge the settings. ⓘ The start display is shown (basic display).

3

4.9 Domestic hot water

4.9.1 Setting the domestic hot water temperature

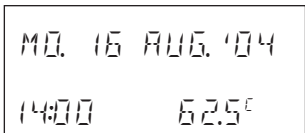

Start - Basic display

1



➔ Tap the "Hot water temperature" key.

2

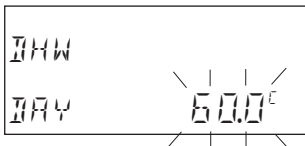

👁️ The currently set hot water temperature is shown flashing on the display.

3

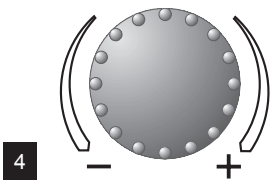

➔ Set the desired domestic hot water temperature by turning the "push & turn button." ⓘ Setting range 10 - 65°C
Factory setting 60°C

4

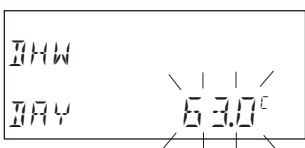

👁️ The selected domestic hot water temperature flashes.

5



➔ Tap the "Domestic hot water temperature" key to acknowledge the temperature setpoint.

6

4.9.2 Manual DHW re-charging

In the case of increased hot water demand, it is possible to conduct a temporary additional heat-up of the calorifier. The calorifier is then re-charged once according to the set daytime hot water temperature.

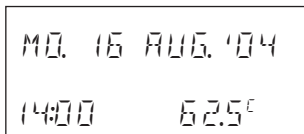

Start - Basic display

1



⇒ Press and hold the "Hot water temperature" key for 3 sec.

2

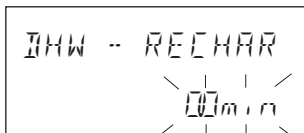

👁️ DHW re-charging time appears on the display; minutes display flashes.

3

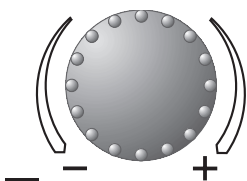

⇒ Set the desired re-charging time by turning the "push & turn button."

ⓘ Setting range 0 - 240 min.

4

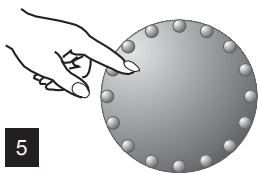

⇒ Tap the "push & turn button" to acknowledge the setting.

5

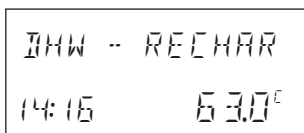

👁️ The selected additional charging time is shown.

ⓘ The information on the display disappears when re-charging is completed.

6

4.9.3 Domestic hot water economy temperature (reduced temperature)

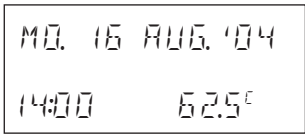

Start - Basic display

1

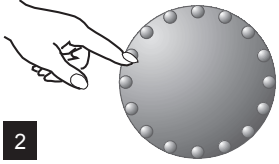

⇒ Press the “push & turn button” for 3 seconds.

2

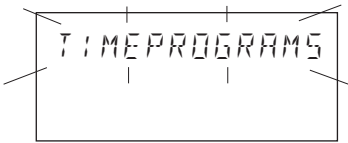

🔗 “Switching times” is shown flashing on the display.

3

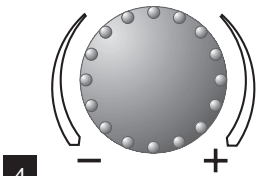

⇒ Change the DHW setting by turning the “push & turn button.” ⓘ Setting range 0 - 240 min.

4

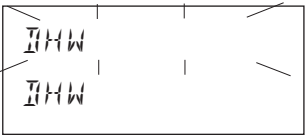

🔗 "DHW" flashes on the display.

5

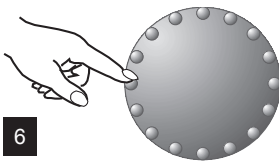

⇒ Tap the “push & turn button” to acknowledge the selected value.

6

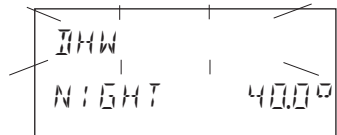

🔗 “DHW” is shown flashing on the display again. ⓘ The temperature shown corresponds to the set reduced DHW temperature.

7

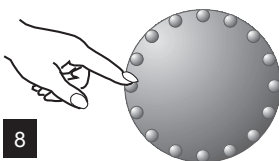

⇒ Tap the “push & turn button” to acknowledge the selected value

8

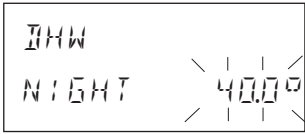

The reduced night-time DHW temperature flashes.

9

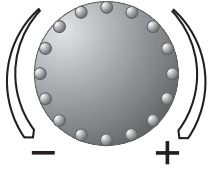

⇒ Select the desired temperature value by turning the “push & turn button.”

10

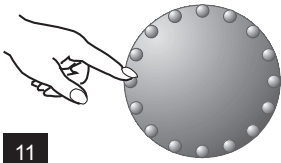

⇒ Tap the “push & turn button” to acknowledge the setting.

11



⇒ Tap the “Operating mode selection” The start display is shown (basic display).

12

4.10 Further settings

4.10.1 Setting the clock

⇒ Follow the steps 1 to 3 described in Chapter 4.9.3 “Domestic hot water economy temperature”!

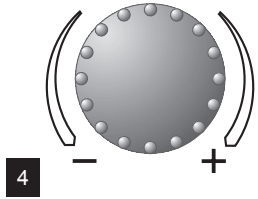

⇒ Select “Time-date” by turning the “push & turn button.”

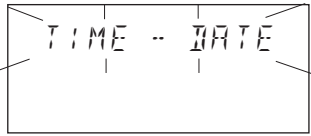

🔗 “Time-date” is shown flashing on the display.

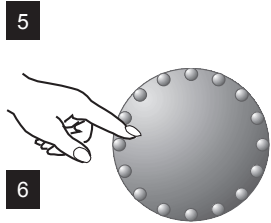

⇒ Tap the “push & turn button” to acknowledge the selected value

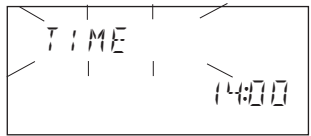

🔗 “Time” is shown flashing on the display.

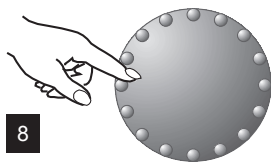

⇒ Tap the “push & turn button” to acknowledge the selected value

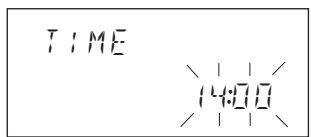

🔗 The “time” is shown flashing on the display.

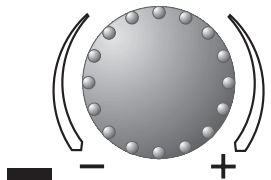

⇒ Set the desired time by turning the “push & turn button.”

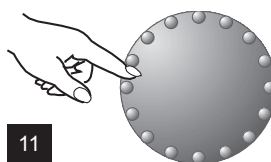

⇒ Tap the “push & turn button” to acknowledge the selected value

ⓘ Return to the starting page and save the set values with .

ⓘ Turn the “push & turn button” to make further settings.

4.10.2 Setting the date

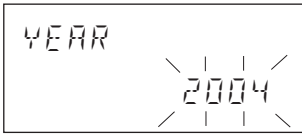

12

🔗 “Year” is shown flashing on the display - acknowledge.
 ➡ Change the year setting by turning the “push & turn button” - acknowledge.

ⓘ Continuation of “Setting the clock” (Chapter 4.10.1).

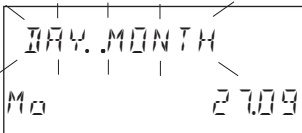

13

🔗 “Day...Month” is shown flashing on the display - acknowledge.
 ➡ Change the Day...Month setting by turning the “push & turn button” - acknowledge.

ⓘ Return to the starting page and save the set values with .

ⓘ Turn the “push & turn button” to make further settings.

4.10.3 Changing between summer and winter time

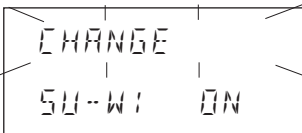

14

🔗 “Change” is shown flashing on the display - acknowledge.
 ➡ Change SU-WI ON or OFF by turning the “push & turn button” - acknowledge.

ⓘ Continuation of “Setting the date” (Chapter 4.10.2).



15

➡ Tap the “Operating mode selection” to acknowledge the selected summer / winter time and to open the basic display.

4.10.4 Setting the language

Follow the steps 1 to 3 described in Chapter 4.9.3 “Domestic hot water economy temperature”!

i You will be prompted for the desired language when switching on the control system for the first time. Changing the language is also possible during normal operation.

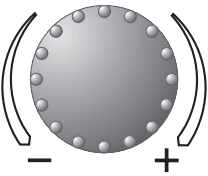
4  → Select “System” on the display by turning the “push & turn button.”

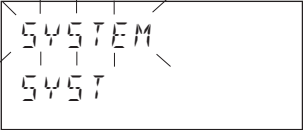
5  **i** “System” is shown flashing on the display.

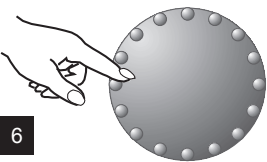
6  → Tap the “push & turn button” to acknowledge the selected value

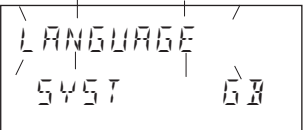
7  **i** “Language” is shown flashing on the display

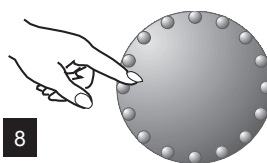
8  → Tap the “push & turn button” to acknowledge the selected value

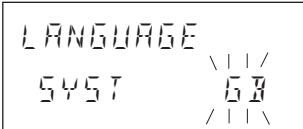
10  **i** Language is displayed - abbreviations for the language are shown flashing.

i DE = German
 GB = English
 FR = French
 IT = Italian
 etc.

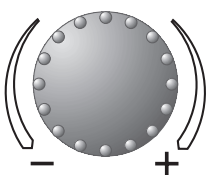
11  → Turn the “push & turn button” to select the desired language and tap to acknowledge.

12  → Tap the “Operating mode selection” key to acknowledge the settings and to open the basic display.

4.10.5 Reloading the standard switching times program - Deleting your own time program

i This function allows you to reset all values preset at the factory!

Follow the steps 1 to 3 described in Chapter 4.9.3 "Domestic hot water economy temperature"!

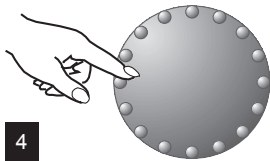

4

⇒ Tap the "push & turn button" to acknowledge the selected value



5

⦿ The letters "HC" are shown flashing on the display.

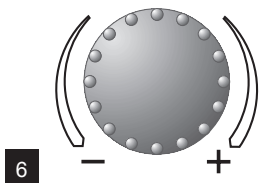

6

⇒ Select "Default times" by turning the "push & turn button."

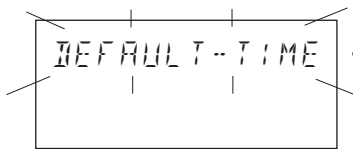

7

⦿ "Default-time" is shown flashing on the display.

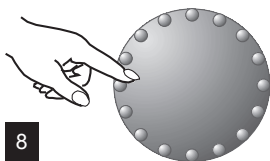

8

⇒ Tap the "push & turn button" to acknowledge the selected value

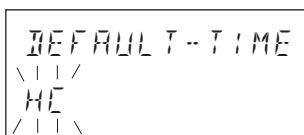

9

⦿ The letters "HC" are shown flashing on the display.

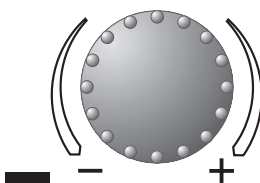

10

⇒ Select the desired heating circuit by turning the "push & turn button."

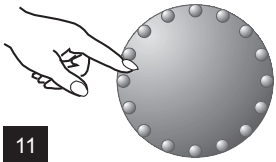

⇒ Tap the “push & turn button” to acknowledge the selected value

11



 “Reset / HC” is displayed.

12

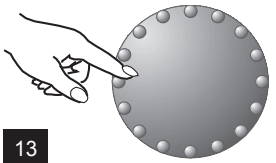

⇒ Press and hold the “push & turn button” for 3 sec.

13

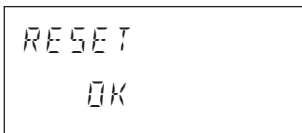

 “Reset / OK” is displayed to acknowledge.

14



⇒ Tap the “Operating mode selection” key to acknowledge the new settings and to open the basic display.

15

4.10.6 Manual operation



The following information is intended for the heating engineer only



This function key is also used for emission measurement when it is only pressed briefly.

- see installation instructions; combustion control

All pumps are operating without restrictions. Available mixers are disconnected and can be operated manually, if necessary, depending on the heat demand.

CAUTION:

- The DHW temperature can reach the level of the boiler temperature setpoint. Danger of scalding if temperature setting is too high !
- In order to protect underfloor heating systems against impermissible overheating during manual operation, it is necessary to implement appropriate safety measures (e.g.: safety temperature limiter with pump switch-off).

Manual operation

PRESS
> 5 seconds

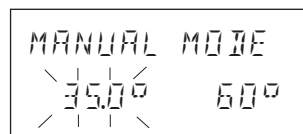

Immediate end

REACTIONS for manual operation

- **Set desired boiler temperature with button!**
- All heating pumps ON
- Mixer without current - manual setting necessary!
- Note the maximum permissible temperature of the panel heating!
- The hot water temperature reaches the set DHW maximum temperature (heating engineer level standard 65 °C).

**Note:**

You can exit manual operating mode and emission measurement mode at any time by tapping the operating mode selection key  (Return to basic display).

4.11 System information

4.11.1 Information key for system temperatures and heating circuit information

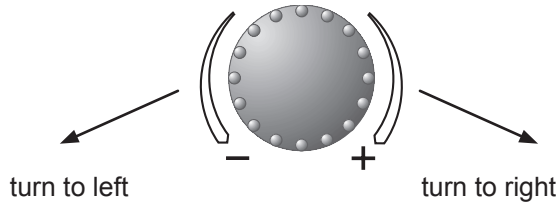
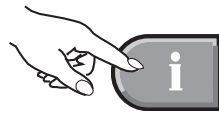

Actual values



Outside temperature

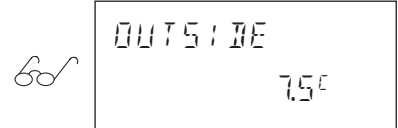

Heat generator temperature

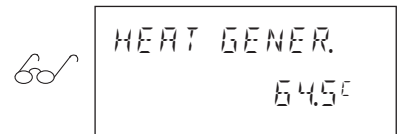

Exhaust

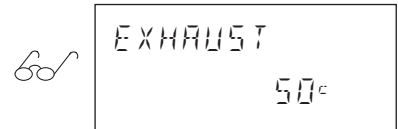

Modulation

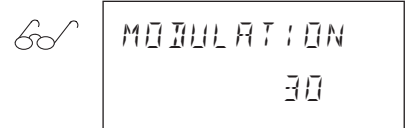

Domestic hot water temperature

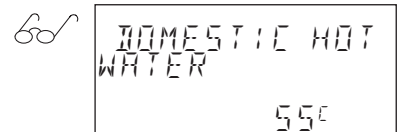

Flow temperature

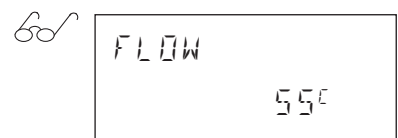

Heat generator Starts

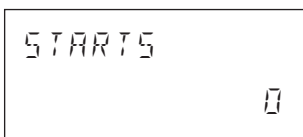

Heat generator hours of operation

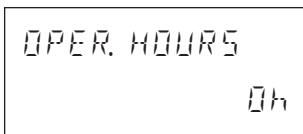

i All temperature values shown represent the current values. Press and hold the "push & turn button" to display the individual set value.

In certain cases, additional information can be displayed.

only in conjunction with room sensor:

- Room temperature direct HC
- Room temperature MC 1
- Room temperature MC 2

i Back to the start screen:
Press briefly

4.11.2 Information on the boiler status
Viewing the current status of the heat generator.

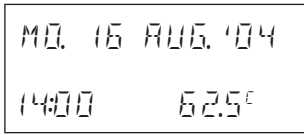

Start - Basic display

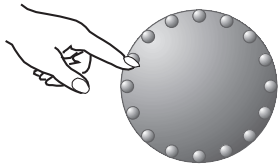

➡ Press the "push & turn button" for 3 seconds.

1

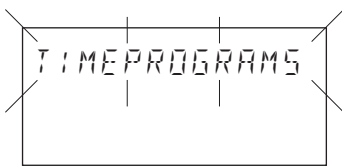

👁️ "SWITCHING TIMES" is shown flashing on the display.

2

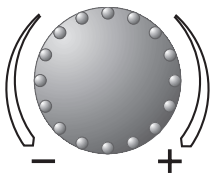

➡ Select "FFA" by turning the "push & turn button."

3

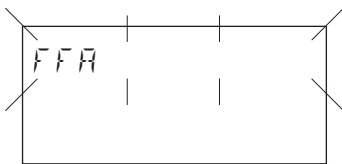

👁️ "FFA" is shown flashing on the display.

4

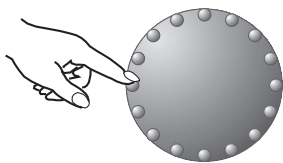

Tap the "push & turn button" to acknowledge the selected value

5

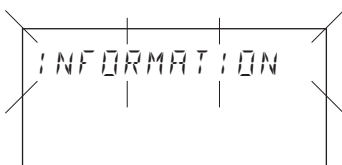

👁️ "INFORMATION" is shown flashing on the display.

6

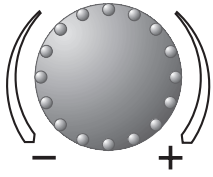

⇒ Tap the "push & turn button" to acknowledge the selected value

7

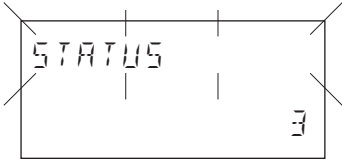

"Status" is shown flashing on the display.

8

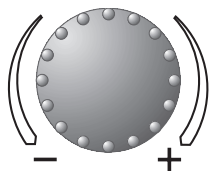

Turn the "push & turn button" to find the following values:

9

STATUS	<p>Boiler status</p> <p>0 Burner OFF, Quiescent state The burner is off and the boiler is in standby mode.</p> <p>1 Ignition phase Burner is filled with pellets and ignition takes place via heating section.</p> <p>2 Fire-bed build-up A stable fire-bed is built up in the burner and the output increased step by step</p> <p>3 Normal operation with modulation Modulating operation, adjustment of the burner output to the required heat demand</p> <p>5 BURN-OUT Burner is switched off and the fire-bed burns out after the setpoint temperature is reached or in order to refill the pellet hopper.</p> <p>6 Fault Burner fault is active (see Chapter 5).</p>
MODULATION	Modulation
BOILER	Boiler flow temperature
EXHAUST	Flue gas temperature
COM.-CHAMBER	Combustion chamber temperature
INSERT SCREW	Stoker/feeder screw temperature
USAGE 1	Consumption meter 1
USAGE 2	Consumption meter 2

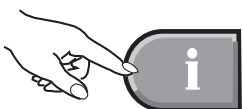

Tap the "Information" key three times. ⓘ The start display is shown (basic display).

10

4.11.3 Displaying and resetting the consumption meters and cleaning messages

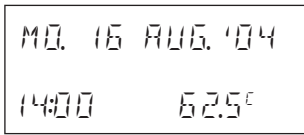

Start - Basic display

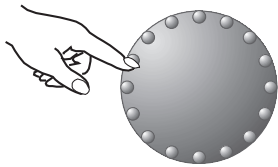

⇒ Press the "push & turn button" for 3 seconds.

1

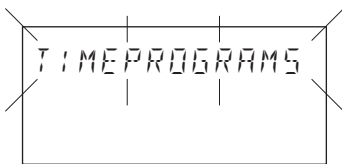

👁️ "SWITCHING TIMES" is shown flashing on the display.

2

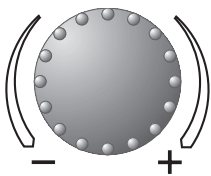

⇒ Select "FFA" by turning the "push & turn button."

3

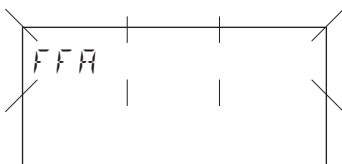

👁️ "FFA" is shown flashing on the display.

4

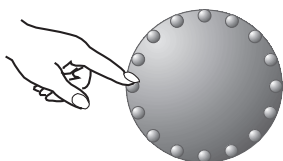

Tap the "push & turn button" to acknowledge the selected value

5

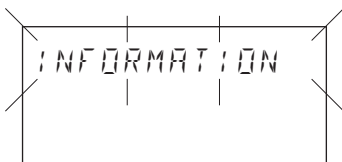

👁️ "INFORMATION" is shown flashing on the display.

6

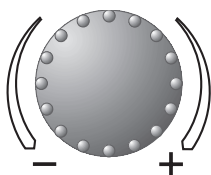

⇒ Select "COUNTER" by turning the "push & turn button."

7

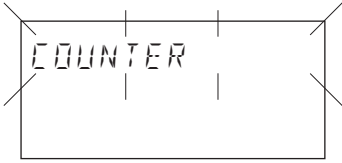

8

"COUNTER" is shown flashing on the display.

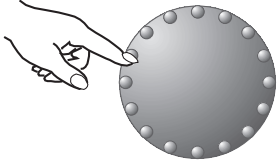

9

Tap the "push & turn button" to acknowledge the selected value

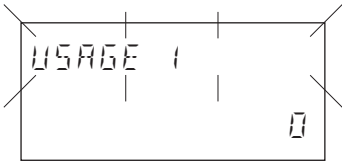

10

"USAGE 1" is shown flashing on the display.

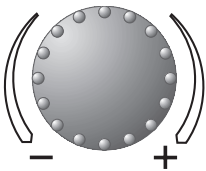

11

Turn the "push & turn button" to find the following values:

Viewing the consumption meters	
USAGE 1	Pellet consumption for period: Pellet consumption since the last pellet delivery or over a specific period.
USAGE 2	Total pellet consumption: Pellet consumption since the last commissioning of the system.
ASH BOX	Pellet consumption since the last time the ash box was emptied.

Resetting consumption meters / cleaning message	
RESET USAGE 1	Resets consumption meter 1 or the pellet consumption within a specific period of time.
RESET USAGE 2	Resets consumption meter 2 or the pellet consumption since the last commissioning of the system.
RESET ASH	Resets cleaning message W:40 or Empty ash box. The cleaning message is issued after a pellet throughput of: 3 tons for type BioLyt (8), 5 tons for type BioLyt (13) and 6 tons for type BioLyt (15-36)
RESET CLEAN	Resets cleaning message W:41 or Clean boiler and burner. The cleaning message is issued after a pellet throughput of: 3 tons for type BioLyt (8) 5 tons for type BioLyt (13) 6 tons for type BioLyt (15) 8 tons for type BioLyt (23,25) 10 tons for type BioLyt (31) 12 tons for type BioLyt (36)

As an example, the procedure for resetting consumption meter 1 is described from step 12 onwards.

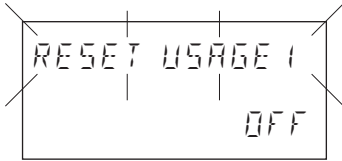

12

"RESET USAGE1" is shown flashing on the display.

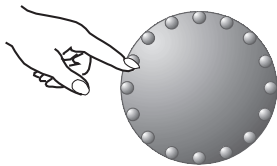

Tap the "push & turn button" to acknowledge the selected value

13

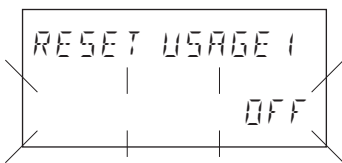

"OFF" is shown flashing on the display.

14

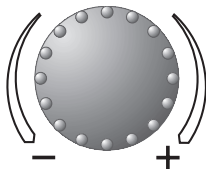

Select "SET" by turning the "push & turn button."

15

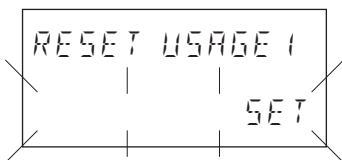

"SET" is shown flashing on the display.

16

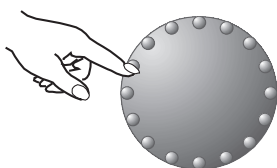

Tap the "push & turn button" to acknowledge the selected value

17

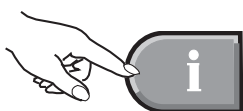

Tap the "Information" key three times.

The start display is shown (basic display).

18

4.11.4 Changing off-periods for the extraction system

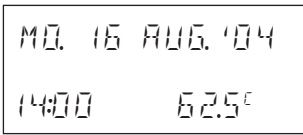

Start - Basic display

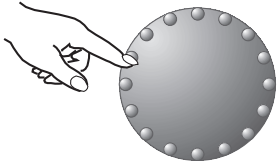

➔ Press the "push & turn button" for 3 seconds.

1

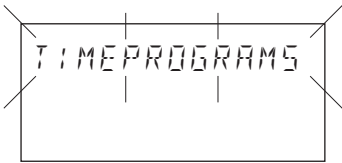

👁️ "SWITCHING TIMES" is shown flashing on the display.

2

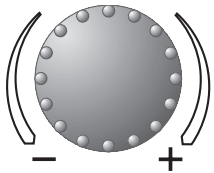

➔ Select "FFA" by turning the "push & turn button."

3

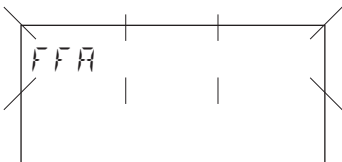

👁️ "FFA" is shown flashing on the display.

4

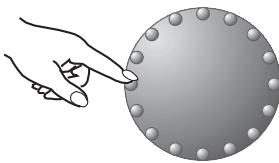

Tap the "push & turn button" to acknowledge the selected value

5

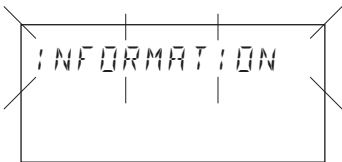

👁️ "INFORMATION" is shown flashing on the display.

6

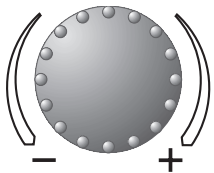

➔ Select "FILLING" by turning the "push & turn button."

7

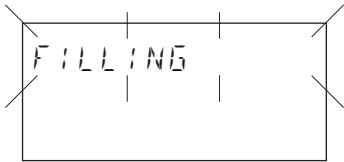

8

 "FILLING" is shown flashing on the display.

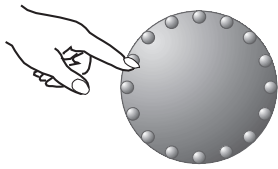

9

 Tap the "push & turn button" to acknowledge the selected value

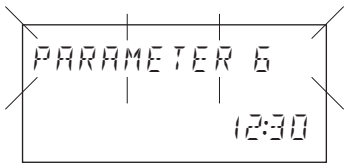

10

 "PARAMETER 6" is shown flashing on the display.

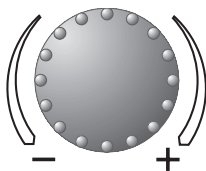

11

 Turn the "push & turn button" to find the following values:

Changing the off-periods		Time
PARAMETER 6	Begin filling off-period 1	12:30
PARAMETER 7	End filling off-period 1	15:30
PARAMETER 8	Begin filling off-period 2	22:00
PARAMETER 9	End filling off-period 2	07:00

The extraction system can be disabled during two periods of time per day. You will find preset values in the table "Changing the off-periods." That is, the extraction system is disabled from 12.30 to 15.30 and from 22.00 to 7.00.

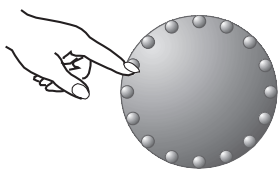

12

 Tap the "push & turn button" to acknowledge the selected value

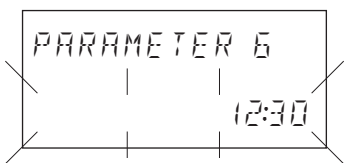

13

 Time "12:30" is shown flashing on the display.

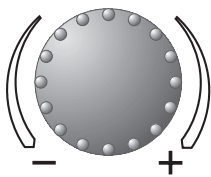

⇒ Set the desired time by turning the "push & turn button."

ⓘ Repeat steps 11-15 if you wish to enter further off-periods.

14

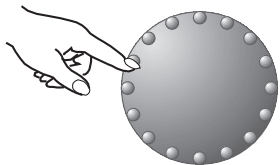

⇒ Tap the "push & turn button" to acknowledge the selected value

15

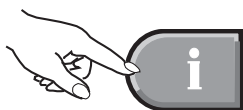



⇒ Tap the "Information" key three times.

ⓘ The start display is shown (basic display).

16

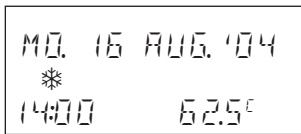
4.11.5 Special symbols



 Ice crystal symbol:
System frost protection activated

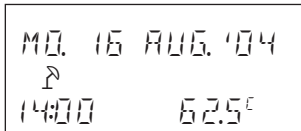

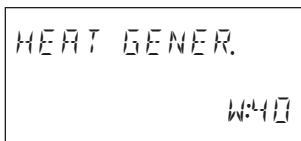

 Sunshade symbol:
Summer disconnection active (heating switched off, DHW according to program).

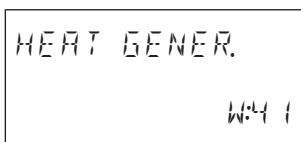

 Cleaning the ash box:
Empty the ash box and then reset counter
"RESET ASH"

BioLyt (8-36)
Cleaning (Chapter 8.1)
Reset counter (Chapter 4.11.3)





 Cleaning the boiler:
Clean boiler and burner and then
reset counter "RESET CLEAN."

BioLyt (8-36)
Cleaning (Chapter 8.2)
Reset counter (Chapter 4.11.3)

4.11.6 Maintenance message



 Maintenance message (optional):
If the basic display screen and the maintenance prompt are displayed in alternation, please call the Customer Service centre. To temporarily suppress this message, press the Manual mode/Emission key  and acknowledge the display "RESET SET" by pressing (3 seconds) the push & turn button.

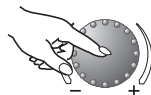

4.11.7 Optional accessories

**Room station RS-T**

The Room station RS-T offers additional operating convenience through de-centralised monitoring and intervention options, since every heating circuit can be assigned with its own individual room station.

Moreover, the central unit contains various control and regulating functions which can only be activated in conjunction with a room station. These include:

- Optimisation functions
- Automatic heating curve adaptation

System-specific temperatures and switching times can be checked and modified via five control keys, also allowing the definition of individual system programs.

The operation of the room station and the boiler control unit is identical.

**Remote setting device with room sensor RFF-T**

This auxiliary device monitors the current room temperature and allows the desired room temperature to be corrected.

With the integrated operating mode key, you can select continuous heating, reduced heating or automatic mode according to a preset automatic program stored in the central unit.

5. Fault repair

5.1 Blocking switch and reset button

i The controller comprises a comprehensive alarm logic which displays the fault type by means of the corresponding error code, depending on the unit version.

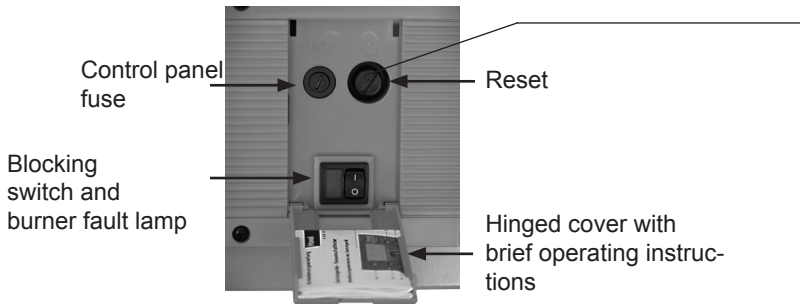

If the display shows "Error," press the Reset button under the hinged cover. If this happens frequently, notify your Customer Service centre.

For further information, see the overview of alarms (Chapter 5.4/ 5.5).

5.2 Display of heating regulator alarms

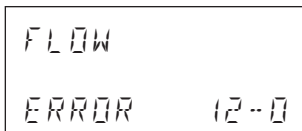

i Example of sensor alarms (short-circuit or interruption)
Error code 10-20 and index 0 or 1

see Chapter 5.4

5.3 Display of boiler controller alarms

If the display shows a fault message with "HEAT GENER," a boiler malfunction has occurred.

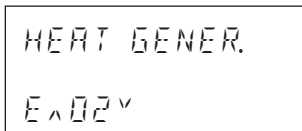

i Example of pellet boiler alarms (interruption/ short-circuit flue gas sensor)

see Chapter 5.5

5.4 Overview of alarms, heating regulator TopTronic®T

Status	Designation	Fault type	Code	Remark
System	External sensor	Interruption	10-0	
System	External sensor	Short-circuit	10-1	
System	Boiler sensor	Interruption	11-0	
System	Boiler sensor	Short-circuit	11-1	
System	Flow sensor 1	Interruption	12-0	MC1=off, YK1=no current
System	Flow sensor 1	Short-circuit	12-1	MC1=off, YK1=no current
System	Storage sensor	Interruption	13-0	
System	Storage sensor	Short-circuit	13-1	
System	VE 2	Interruption	14-0	
System	VE 2	Short-circuit	14-1	
System	VE 2	Alarm	14-7	
System	VE 3	Interruption	15-0	
System	VE 3	Short-circuit	15-1	
System	VE 3	Alarm	15-7	
System	VE 1	Interruption	16-0	
System	VE 1	Short-circuit	16-1	
System	VE 1	Alarm	16-7	
System	Solar tank sensor	Interruption (KSPF)	17-0	
System	Solar tank sensor	Short-circuit (KSPF)	17-1	
System	Flow sensor 2	Interruption	18-0	MC2=off, YK2=no current
System	Flow sensor 2	Short-circuit	18-1	MC2=off, YK2=no current
System	Collector sensor	Interruption (KVLFF)	19-0	
System	Collector sensor	Short-circuit (KVLFF)	19-1	
System	Room sensor (RS)	Interruption	20-0	
System	Room sensor (RS)	Short-circuit	20-1	
System	Burner 1	No switching off (1 min)	30-2	With par. log. alarm can be switched off
System	Burner 1	No switching on (10 min)	30-3	With par. log. alarm can be switched off
System	Burner 2	No switching off (1 min)	31-2	With par. log. alarm can be switched off
System	Burner 2	No switching on (10 min)	31-3	With par. log. alarm can be switched off
System	Exhaust gas temperature	Exceeding	33-5	
System	Exhaust gas temperature	SLT triggered	33-8	
System	Cleaning stage 1	Triggering by date	40-1	
System	Cleaning stage 1	Triggering by interval	40-2	
System	Cleaning stage 1	Triggering by counter	40-4	
System	Maintenance stage 1	Triggering by date	41-1	
System	Maintenance stage 1	Triggering by interval	41-2	
System	Maintenance stage 1	Triggering by counter	41-4	
System	Cleaning stage 2	Triggering by date	42-1	
System	Cleaning stage 2	Triggering by interval	42-2	
System	Cleaning stage 2	Triggering by counter	42-4	
System	Maintenance stage 2	Triggering by date	43-1	
System	Maintenance stage 2	Triggering by interval	43-2	
System	Maintenance stage 2	Triggering by counter	43-4	

Status	Designation	Fault type	Code	Remark
Logical	Boiler temperature	Not reached (90 min)	50-4	
Logical	Tank temperature	Not reached (4 h)	51-4	
Logical	Flow temperature MC1	Not reached (1 h)	52-4	
Logical	Flow temperature MC2	Not reached (1 h)	53-4	
Logical	Room temperature HC	Not reached (3 h)	54-4	
Logical	Room temperature MC1	Not reached (3 h)	55-4	
Logical	Room temperature MC2	Not reached (3 h)	56-4	
System	Lock by energy supply company ST 2	Address collision	70-0	
System	Activity	No T2B signal	70-1	
System	Activity	No FA signal	70-6	
System	Activity	Regulator with address 10 is missing	70-8	
System	Activity	Data bus error	70-9	No Hoval regulator
System	HP return sensor	Return min. temp. below setpoint	85-4	
System	HP return sensor	Return max. temp. exceeded	85-5	
System	QF	Heat source min. temp. below setpoint	86-4	
System	QF	Heat source max. temp. exceeded (cooling operation)	86-5	
System	QF	Fault heat source sensor	--	Standard signal «VE-x»
System	WPS	Variable input HP fault	87-7	
System	Pulse counter	No pulse (5 min)	90-0	
System	Fault	Warning	W:XX	Warning in automatic firing device
System	Fault	Lock-out	E:XX	Fault in automatic firing device
System	Fault	Blocking	B:XX	Fault in automatic firing device

5.5 Overview of alarms, boiler controller

Error code	Description	What should be done?
E:01	STB (safety temperature limiter)	1. Boiler STB has tripped To unlock, open the front door; STB is located on the underside of the control box. Remove cover and press the button in. Then acknowledge the fault by pressing the reset button.
E:02/ E:03	Interruption/ short-circuit, flue gas sensor	Contact Hoval heating engineer
E:04/ E:05	Interruption/ short-circuit, combustion chamber sensor	Contact Hoval heating engineer
E:06/ E:07	Interruption, boiler sensor	Contact Hoval heating engineer
E:12	Feed signal, stoker/feeder screw: screw at a standstill	Contact Hoval heating engineer
E:16	Number of start attempts exceeded (minimum combustion chamber temperature not reached after fire-bed build-up)	Clean boiler (see Chapter "Maintenance"); if fault occurs repeatedly, contact Hoval heating engineer
E:29	Vacuum not OK	Clean burner and boiler (see Chapter "Maintenance"); if fault occurs repeatedly at short intervals, contact Hoval heating engineer
E:33	Ignition not successful (no increase in combustion chamber temperature during the ignition process)	Clean boiler (see Chapter "Maintenance"); if fault occurs repeatedly, contact Hoval heating engineer
E:37	Filling time exceeded, but pellet hopper is empty	1. Check whether there are pellets left in the storage room 2. Check whether the suction hoses are clogged with pellets at some point Otherwise: Contact Hoval heating engineer.
E:38	Filling process aborted due to: 1. Screw motor overheating (if fitted) 2. Suction turbine overheating 3. Storage room door contact switch (if fitted) opened	1./ 3.: Check suction hoses and screw transfer station for blockages and remove if necessary. 2. Close the door to the storage room
E(45)	Only when using switchover unit with suction probes: All available suction probes have been approached and the maximum filling time has expired, but the pellet hopper is not completely full	1. Check whether the conveyor hoses are blocked at some point 2. Check whether there are pellets available at the suction probes in the storage room 3. Otherwise: Contact Hoval heating engineer
E:46	Only when using switchover unit with suction probes: Switchover unit is blocked, the maximum time for the switchover process has been exceeded 2x	Contact Hoval heating engineer
B:20	Maximum boiler temperature exceeded	
B:21	1. Blocking switch active or 2. Ash box not fitted or not fitted correctly	Set blocking switch to "1" or fit ash box correctly
B:32	Filling level sensors, wrong signal order	1. Check pellet hopper for bridging (lower sensor is "in the open" although the upper sensor is still covered with material) as a result of too much dust in the fuel 2. Empty pellet hopper and clean it, remove dust from the sensors 3. Otherwise: Contact Hoval heating engineer
W:08/ W:09	Interruption/ short-circuit, return sensor	Contact Hoval heating engineer
W:10/ W:11	Interruption/short-circuit burner buffer sensor (if fitted)	Contact Hoval heating engineer
W:17	Filling time exceeded	1. Check whether pellets are available in the storage room 2. Check if pellets are blocking the vacuum hoses at some point Otherwise: Contact Hoval heating engineer.
W:18	Storage room empty (only if filling level monitoring is fitted in the storage room)	Order pellets
W:19	Lambda probe test failed	
W:22	Filling blocked through off-period	
W:23	Fire-bed extinguished during operation	
W:24	Lambda probe test aborted as a result of flue gas temperature	
W:30	Low vacuum (10% increase active)	
W:34	Value measured by the lambda probe does not recover	
W:40	Empty ash box	Empty ash box and reset counter
W:41	Boiler cleaning necessary	Clean boiler and burner and reset counter
W:42	Only with manual filling without autom. filling system: pellet hopper empty.	Top up with pellets

5.6 Checklist in case of faults

Fault	Check/cause	Remedy	Chapter
Pellet boiler does not start	- Is current present?	- Check fuses. Turn on main switch	
	- Is the red fault indicator lit?	- Press the reset button (12) - Contact customer service	4.4.4
Radiators do not heat up	- Are the slide valves in the heating flow and return open?	- Open them	
	- Is the TopTronic®T timer set correctly?	- Check as described in operating instructions for the heating regulator	4.7
	- Check water level and pressure	- Top up and vent heating	
	- Are the radiator valves open?	- Open	
	- The heating circulation pump is not running	- Open locking screw Turn end of shaft vigorously with a screwdriver until there is no longer resistance	
	- Mixer does not open automatically	- Open manually; Call Customer Service	
No hot water	- The charging pump is not running	- Unscrew the locking screw Turn shaft end vigorously with a screwdriver until there is no longer resistance	
	- Is there air in the charging pipe?	- If so, vent by hand - Actuate automatic air vent by hand	

Please note!



Please use the above checklist when carrying out the checks in the case of malfunctions.

If you are not able to resolve the fault, please contact the heating engineer or Hoval Customer Service.

6. Checking the water level



If the system pressure is too low (check pressure gauge), inform your installer or top it up with water.

Refilling the heating system

The heating system can normally be filled and topped up with mains water. In exceptional cases, the water quality may vary strongly and it might not always be suitable for filling the heating system (highly corrosive or very hard water). Please contact a certified specialist company in such cases.

Follow the procedure below

- Set main switch to "O."
- The shut-off valves in the flow and return lines must be open.
- The boiler filling and drain cock is accessible from the back of the boiler (right at the bottom, in the centre).
- Connect a hose between the filling cock and the water tap:
 - Fill the hose with water before establishing the connection to prevent any air from entering the heating system.
 - Unscrew the hose again after filling to break the connection reliably.
- Slowly fill with water while checking the water level on the hydrometer or manometer.
- Open the bleed valves briefly after topping up until all the air has been vented from the radiator.

7. Commissioning

When commissioning the system, also observe the notes in the installation manual.

1. Checks:

- Are the slide valves in the heating flow and return lines open?
- Is the combustion air supply into the boiler room adequate?
- Is the main switch on the boiler control unit set to "ON"?
- Is the combustion chamber closed?
- Is the ash box fitted?
- Is the cleaning cover (top) closed?
- Is the pellet hopper full?
- Is the pellet hopper cover closed?

2. Starting the burner:

- Takes place automatically via the heating regulator when there is a heat demand.

8. Maintenance

Your Hoval BioLyt (8-36) pellet boiler is equipped with a fully automatic cleaning device. Both the ash from the burner and the fly ash in the heat exchanger are discharged automatically into the ash box. Thus, the only cleaning work you need to perform regularly is to empty the ash box. All other cleaning and maintenance work should be performed once per year (or more frequently, depending on the pellet throughput) by a heating engineer.

8.1 Cleaning the ash box

8.1.1 Empty the ash box

Check the fill level in the ash box regularly. The ash box must be emptied at the latest when W:40 appears on the display (if activated in the boiler controller).

Depending on the boiler output, the ash box must be emptied at the latest after the following amount of pellets has been consumed:

- 3 tons for type BioLyt (8)
- 5 tons for type BioLyt (13)
- 6 tons for type BioLyt (15-36)

8.1.2 Removing the ash box

1. Open the front door and then release the spring clips (1, Fig. 02) on both sides of the ash box.
2. As soon as you pull the ash box away from the boiler, the system is switched off and error code B:21 appears on the display.



Fig. 02

3. Rotate the cover on the back of the ash box over the opening (Fig. 03).



Fig. 03



Do not empty the ash until it is cold (danger of fire as a result of glowing embers)!



When filled right to the rim, the ash box can weigh up to 40 kg!

Use the extendible handle only to pull out the ash box!

4. To do this, fully extend the handle (2, Fig. 04) until it engages.

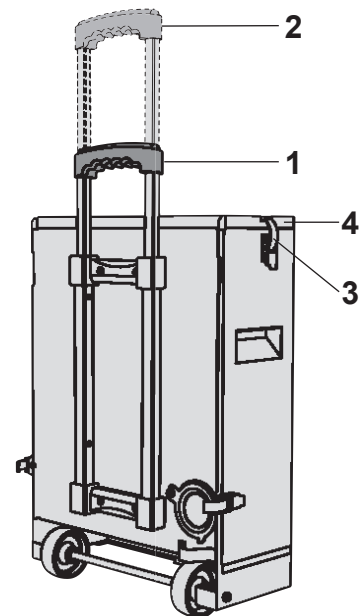

Fig. 04

5. To lift the ash box, move the extendible handle to first position (1, Fig. 04) until it engages and place your second hand under the ash box.

6. To empty the box, release the two top spring clips (3) and remove the lid (4).
7. When you have emptied the box, ensure that the lid closes tight (check sealing)!

8.1.3 Fitting the ash box

1. Open the cover (Fig. 03) on the back.
2. Remove the excess ash from the ash discharge screw. If you use a vacuum cleaner, be careful not to draw in any ember particles, as otherwise, your vacuum cleaner may be destroyed.
3. Slide the ash box onto the system and position it with the help of the stop on the top right (2, Fig. 02). The system detects that the ash box has been replaced and switches on again.
4. Lock the ash box in position by closing the two bottom spring clips (1, Fig. 02)!

8.1.4 Resetting the special display "W:40"

The message "W:40" must be reset in the boiler controller. This deletes the pellet consumption meter reading (since the last time the ash box was emptied, Chapter 4.11.3).

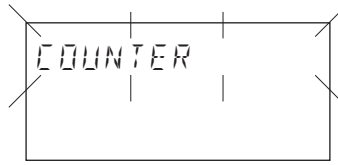

Acknowledge the selected value.

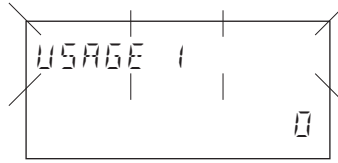
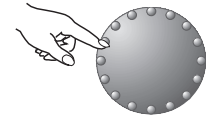

Turn the push & turn button to "RESET ASH."

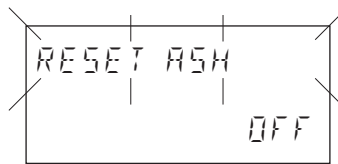
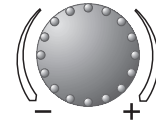

Acknowledge the selected value.

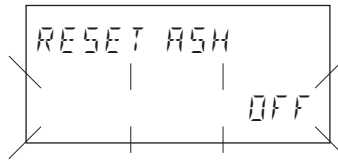
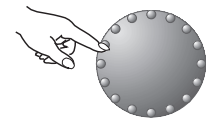

Turn the push & turn button to "SET."

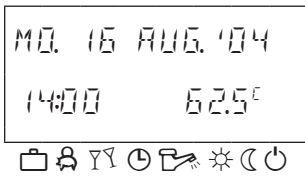
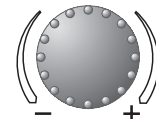

Press for three seconds.

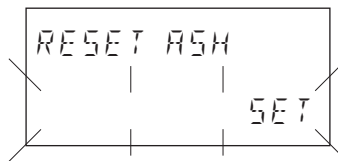
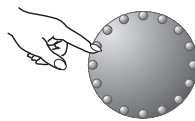

Acknowledge the selected value.

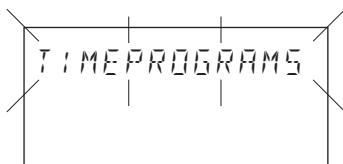
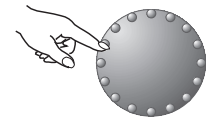

Turn the push & turn button to "FFA."

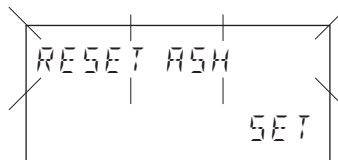
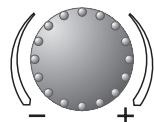

Return to the basic display, briefly press the "Information" key three times.

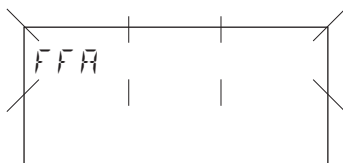

Acknowledge the selected value.

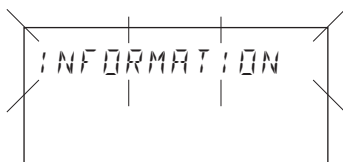
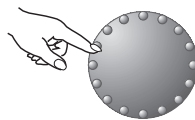

Turn the push & turn button to "COUNTER."

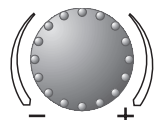

8.2 Annual maintenance or major maintenance

Once per year or at the latest when the message W:41 appears on the display (if activated in the boiler controller), «annual maintenance» must be carried out by a heating engineer.

! Only by heating engineers

Depending on the boiler output, major maintenance must be performed at the latest after the following amounts of pellets have been consumed (even if this is the case before one year has expired): BioLyt (8) after 3 tons, BioLyt (13) after 5 tons, BioLyt (15) after 6 tons, BioLyt (23,25) after 8 tons, BioLyt (31) after 10 tons, BioLyt (36) after 12 tons.

Some of the following tasks may need to be performed earlier, depending on the pellet quality and the boiler operating mode.

8.2.1 Preparation

- Switch the boiler off with the blocking switch (see 4.4.4)
- Allow the boiler to cool down for at least 30 minutes.
- Remove the ash box.

Tip: The front door can be easily unhooked at the two hinges; this allows easier access to the burner and the combustion chamber for maintenance purposes.

⚡ The boiler must be disconnected from the mains before performing annual maintenance (all pole main switch, main fuse or in Switzerland the mains plug).

8.2.2 Cleaning the flue gas collector

1. Open the cover of the flue gas collector:
 - Release four screws (1, Fig. 05).
 - Grip the cover by the handles (1a), turn it slightly in anti-clockwise direction and lift off.

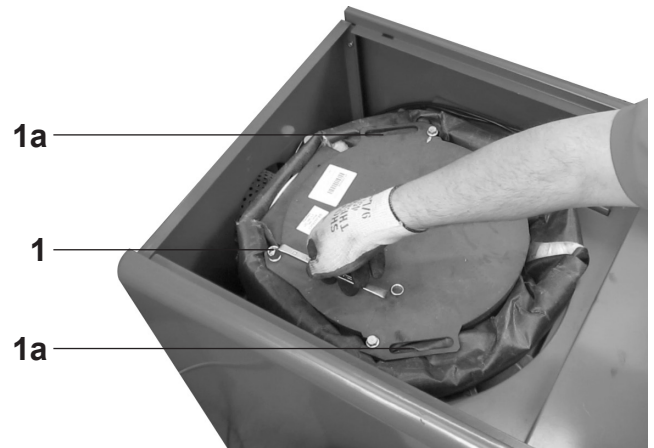

Fig. 05

2. Extend the regulator unit upwards approx. 20 cm (Fig. 06) and move it up and down firmly several times (approx. 10...20 cm)
3. Hook the regulator unit back in correctly!
4. Clean the impeller (4) of the induced-draught fan using a brush and vacuum cleaner; use a scraper to remove any encrusted deposits.
5. Vacuum clean the entire flue gas collector

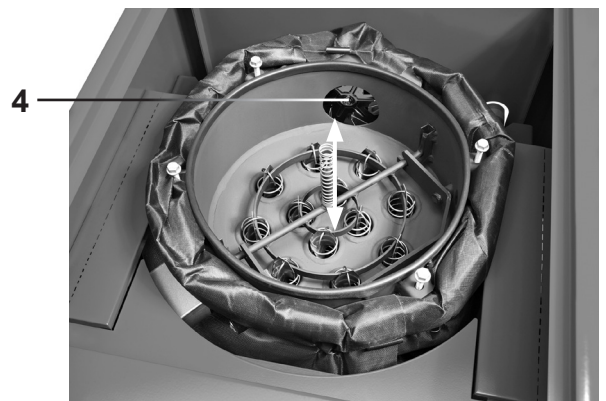

Fig. 06

6. Lubricate the following components (Fig. 07) with adhesive lubricating grease:
 - Guide rails (A)
 - Lever-shaping pipe contact points (B)
 - Lever pivot points (C)
 - Eccentric disc (D)
7. Refit the flue gas collector cover so that it is sealed!

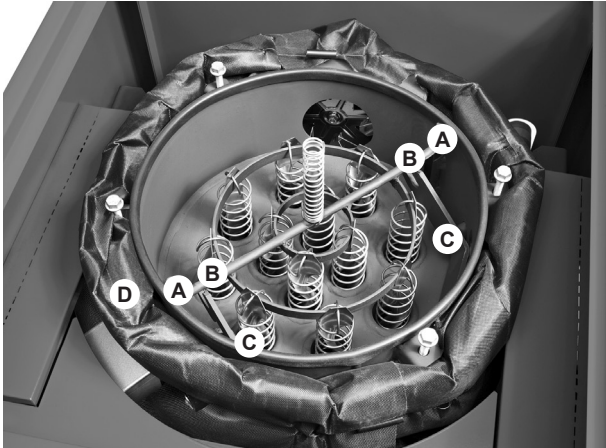

Fig. 07

8.2.3 Cleaning the flue gas sensors

1. Remove the rear casing panels
2. Remove the lambda probe (2, Fig. 08) and clean using a brush and vacuum cleaner
3. Remove flue gas temperature sensor with immersion sleeve and clean

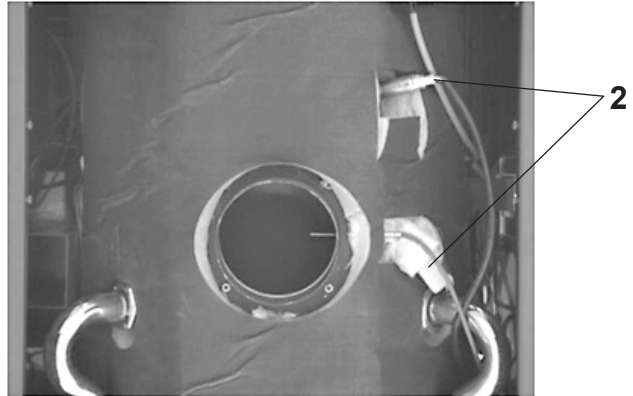

Fig. 08

8.2.4 Cleaning/ checking the post-combustion ring and dust separator

Overview

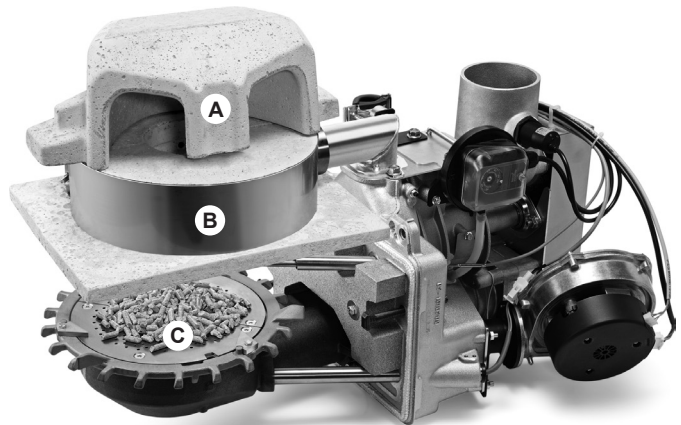

Fig. 09

Legend

A	Dust separator
B	Post-combustion ring
C	Burner

1. Remove the burner cover after first releasing the self-tapping screw on the back of the pellet hopper.
2. Dismantle the secondary air connection (1, Fig. 10) (release screws and remove).



Fig. 10

3. The refractory bricks are removed as described in the installation instructions, see Chapter 2.2.1.1.
4. Clean the post-combustion ring (B, Fig. 09) incl. air nozzles and check the seal for the secondary air pipe.
5. Clean dust separator (A, Fig. 09).

8.2.5 Cleaning the combustion chamber, burner and ignition tube

Overview

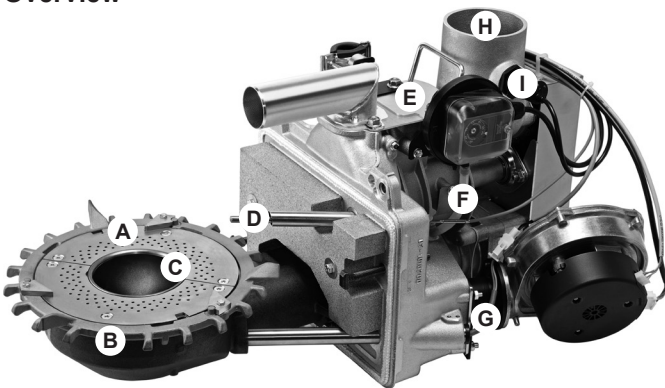

Fig. 11

Legend

Burner	A	Burner plate with primary air bore holes
	B	Rotating grate with wiper
	C	Ignition tube
	D	Tube with combustion chamber temperature sensor
Burner mechanism	E	Maintenance aperture
	F	Hose for negative pressure measurement
	G	Ignition rod with glow igniter
	H	Pellet drop-shaft
	I	Filling level sensor

1. Clean the combustion chamber:
 - Use the vacuum cleaner to remove the ash above the burner plate in the combustion chamber.

Tip: Leave the ash in the bottom section, as the cushion of ash provides insulation and leads to more effective combustion.
 - Carefully clean and vacuum clean the combustion chamber temperature sensor (1, Fig. 12).
2. Clean the burner and ignition tube:
 - Use the steel brush to clean the burner plate (2). Use a pointed object, e.g. a drawing pin, to scrape deposits from the primary air apertures and remove using a vacuum cleaner.
 - Using a hammer and/or screwdriver, carefully remove any deposits in the burner pan (2a).

CAUTION: Do not damage the ignition tube.
 - Carefully vacuum the area around the ignition tube. Pull the ignition tube out, clean it and reinsert it.



Fig. 12

8.2.6 Cleaning/ checking the burner mechanism

1. Open the maintenance aperture (E, Fig. 11) of the burner mechanism via the rotary valve and remove fine particles using a vacuum cleaner.
2. Remove fine particles from the pellet drop-shaft (H) using a vacuum cleaner and remove dust adhering to the filling level sensor.
3. Disconnect the hose for negative pressure measurement (F) and clean the filter.
4. Carefully remove the glow igniter from the ignition rod (G), remove ash residue and vacuum clean.

8.2.7 Cleaning/checking the pellet hopper and suction module (if present)

1. Disconnect conveyor hoses (1, Fig. 13) and remove the suction module (1a).
2. Remove fine particles and dust deposits from the pellet hopper and vacuum clean
3. Check/ clean the seal between the suction module and the pellet hopper (3)

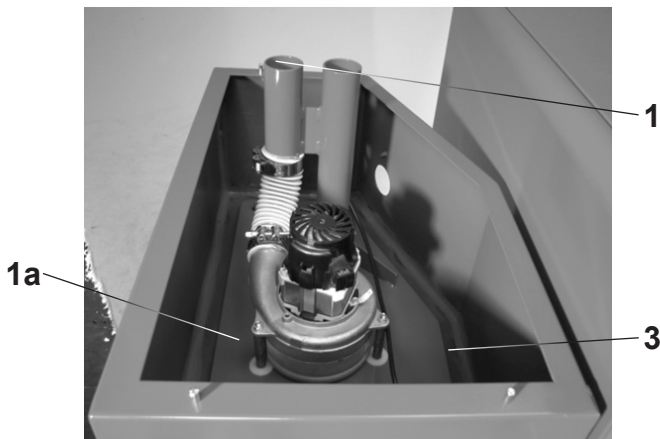

Fig. 13

4. Clean filling level sensor (4, Fig. 14) and inspect the sensor cable for damage.
5. Clean the grille of the suction turbine (5).
6. Remove dust adhering to the sealing surface.

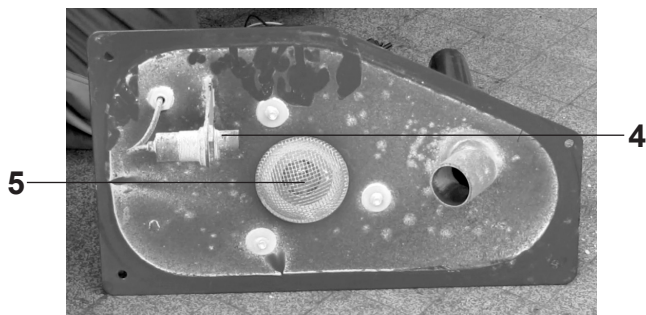

Fig. 14

8.2.8 Further information ...

The following components are maintenance-free and do not require servicing:

- Primary air blower
- Rotary valve
- Motor and chain drive for metering screw, rotary valve and modulating stoker
- Motor, ash screw and cross-feeding auger
- Suction turbine

After completing annual maintenance:

- Carry out relay test and check all components for correct functioning
- Clean the boiler casing
- Fill out the maintenance log
- Note the operating hours and number of burner starts

8.3 Cleaning / checking the storage room

- Empty the storage room regularly, at the latest every 3 years, to remove fine residue.
- Check the storage area ventilation annually (opening on the filling and suction cover) and clean the ventilation apertures if necessary.
- Check that the warning sticker is attached to the storage room access door as prescribed in the note under 2.3. All persons with access to the storage room must be informed of the possible hazards.

9. How you can save energy

The room temperatures and the operating periods of the heating system have a significant influence on fuel consumption.

Lowering room temperature by 1°C will result in a fuel saving of up to 6%. For this reason, bear in mind the following tips:

- It pays to turn off the radiators in unused rooms, as long as there is no risk of frost and no moisture damage to the building structure or furniture is to be expected.
- Set the switch on your heating regulator to “Summer” as soon as the daily average outside temperature exceeds 12°C.
- In the main living areas, additional heat is often generated by people, televisions, fire places, tiled stoves and also direct sunlight. These cannot be compensated for by a weather-dependent regulator. It may be worth installing thermostatic radiator valves in these rooms (if not already fitted).

Draughts in the home are not only unpleasant, but also indicate that heating energy is being lost.

You can save fuel if you ...

- Keep the doors and windows closed in winter.
- Operate kitchen and bathroom ventilation fans only when vapours and smells need to be extracted.
- Ventilate only briefly, but thoroughly.
- Seal doors and windows to prevent constant leakage losses.

Insulation will help retain precious heat.

Take advantage of these possibilities and...

- Close the window and door shutters at night.
- Draw the curtains in the evening.
- Make sure that heating and hot water pipes are insulated in unheated rooms.

Keeping the temperature of the radiators as low as possible will prevent unnecessary heat losses. For this reason, it is important to ensure that the radiator can release its heat into the room without any obstructions. You should therefore avoid:

- Covered radiators
- Floor-length curtains in front of radiators
- Windowsills covered with objects that prevent any air ingress.

Savings are also possible for water heating.

- Set the domestic hot water temperature as low as possible. Find out at what temperature there is still sufficient hot water available.
- If you have installed a hot water circulation pump, it is worth switching it off during the night with a timer.

10. Instructions concerning proper disposal of individual system components

The individual components (particularly boiler body, refractory bricks, casing panels, insulation mats and electric control) must be disposed of separately.

United Kingdom

Hoval Ltd.

Northgate
Newark
Nottinghamshire NG24 1JN
Phone +44 1636 67 27 11
Fax +44 1636 67 35 32
www.hoval.co.uk

Switzerland

Hoval AG

General Wille-Strasse 201
CH-8706 Feldmeilen
Phone +41 44 925 61 11
Fax +41 44 923 11 39
www.hoval.ch

Germany

Hoval GmbH

Humboldtstrasse 30
D-85609 Aschheim-Dornach
Phone +49 89 92 20 97-0
Fax +49 89 92 20 97-77
www.hoval.de

Austria

Hoval Gesellschaft mbH

Hovalstrasse 11
A-4614 Marchtrenk
Phone +43 50 365 - 0
Fax +43 50 365 - 5005
www.hoval.at

Italy

Hoval s.r.l.

Via per Azzano San Paolo, 26/28
I-24050 Grassobbio (BG)
Phone +39 035 52 50 69
Fax +39 035 52 69.59
www.hoval.it

France

Hoval SAS

6, rue des Bouleaux
F-67100 Strasbourg
Phone +33 3 88 60 39 52
Fax +33 3 88 60 53 24
www.hoval.fr