



The design hinge with integrated Silent System:
Sensys

Technik für Möbel

Hettich

Benefits at a glance: Sensys



High quality Silent System invisibly integrated in the hinge arm

Elegant cover cap for the hinge cup, also available for the hinge arm



Sensys makes your furniture safer.

The fast release button is elegantly concealed by the hinge arm. This reliably prevents the door from being released unintentionally.

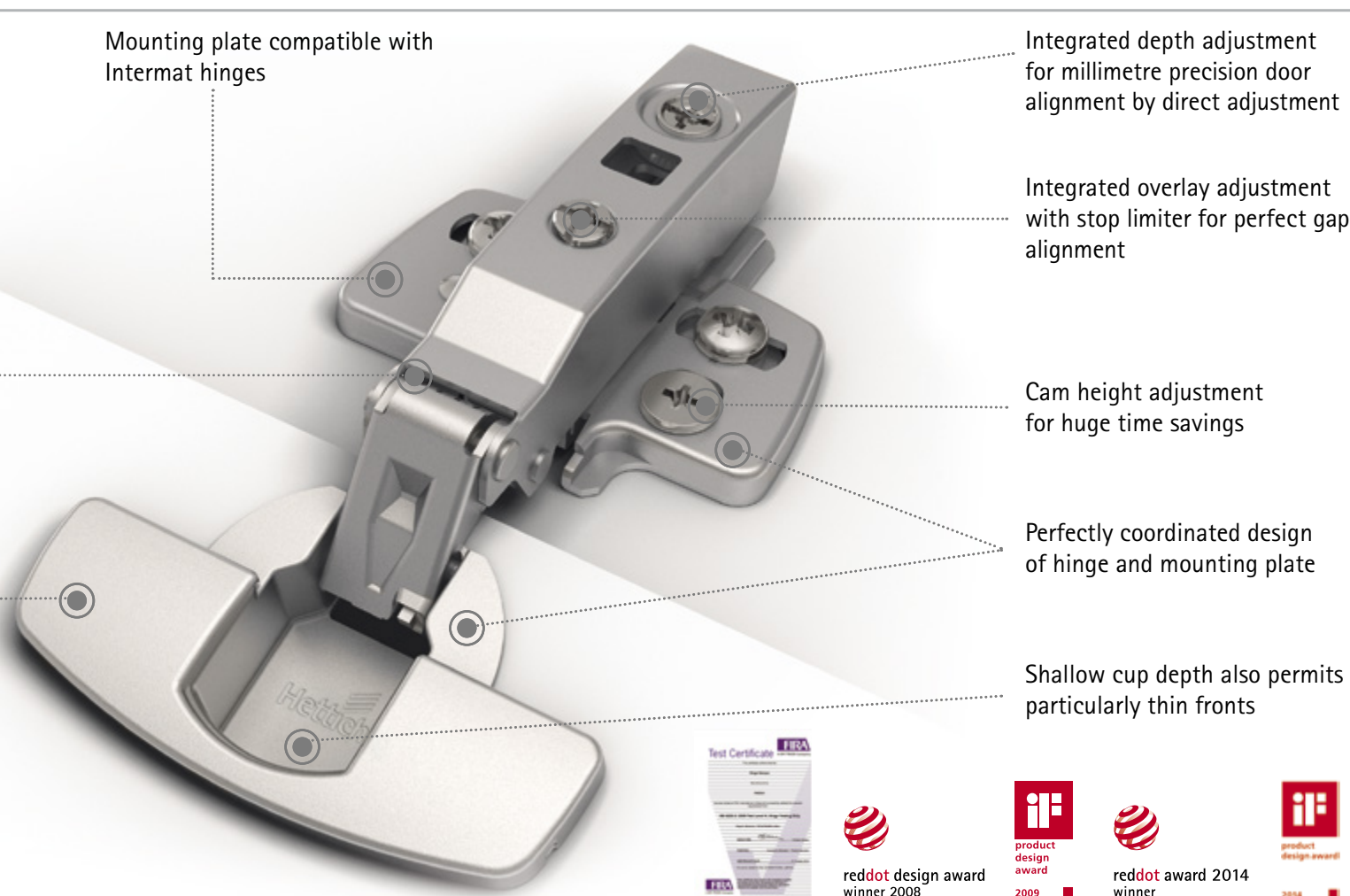

Mounting plate compatible with Intermat hinges

Integrated depth adjustment for millimetre precision door alignment by direct adjustment

Integrated overlay adjustment with stop limiter for perfect gap alignment

Cam height adjustment for huge time savings

Perfectly coordinated design of hinge and mounting plate

Shallow cup depth also permits particularly thin fronts

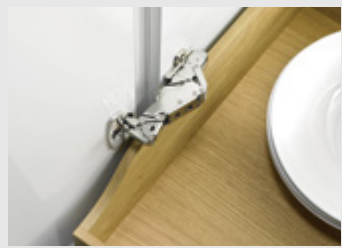

Zero protrusion hinge for optimum use of storage space
Plan internal pot-and-pan drawers in maximum width and without spacers. The Sensys zero protrusion hinge opens the door so wide that it does not get in the way of the internal pot-and-pan drawer.



Narrow gaps between thick doors? Not a problem!
The Sensys thick door hinge confidently moves even heavy doors in a way that's noticeably felt. As a capable performer, it gives you creative design flexibility – for furniture design to tick all the boxes with your clients.

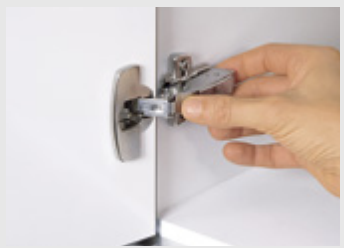

Time saving assembly
Tool-less clip on assembly means hinge and mounting plate can be put together in almost record breaking time. Direct adjustment of gap alignment also saves a lot of time. Fast assembly options for the cup additionally facilitates installation.

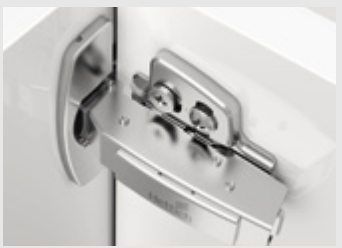

Differentiation despite lower inventory costs
Sensys mounting plates are also compatible with Intermat hinges. This means you can fit standardised carcass elements with fronts / hinges of different qualities. And set your furniture range apart with minimal effort.

Fast assembly concealed hinge

- ▶ Sensys with integrated Silent System
- ▶ Key selling points



Put the final touch to your furniture design with Sensys

Sensys helps to bring a look of harmony to your furniture. The hinge's multiple award winning design is not only ideal for complementing your furniture from a practical aspect but also in terms of aesthetic appeal. With Sensys, you are sure to excite customers with an eye for detail. If you wish, you can be part of the product with your own logo on the hinge's cover cap.



Optimum Silent System performance all automatically – without the effort of adjustment

The Sensys hinge's Silent System always closes any door gently and reliably. Whether small and light, or large and heavy. The exceptionally wide automatic closing angle of 35° effortlessly slows down heavy doors even closed with a hard push.



Avoid complaints – with Sensys

Heat from direct sunlight or low temperatures in unheated new buildings can impair the performance of hinges – and also the perceived quality of your furniture as a result. Not so with Sensys: The Silent System is designed for perfect operation across an exceptionally wide temperature range from +5°C to +40°C.



Better Silent System performance reduces your costs

On large cabinet doors, the best in class performance you get with Sensys pays particular dividends: compared to other hinges, you often need one or two Sensys hinges less to obtain constant Silent System excellence.

Fast assembly concealed hinge



- ▶ Sensys
- ▶ Range summary



Sensys 110° standard hinge
▶ Sensys 8645i / 8645 / 8675
▶ 110° opening angle

6 - 9



Sensys 95° thick door hinge
▶ Sensys 8631i / 8631 / 8661
▶ For narrow gaps between thick doors

10 - 15



Sensys 165° wide angle hinge
▶ Sensys 8657i / 8657 / 8687
▶ For unobstructed access to storage space

16 - 19



Sensys W30 angle hinge
▶ Sensys 8639i W30 / 8639 W30 / 8669 W30
▶ For 30° face angles

20 - 23



Sensys W45 angle hinge
▶ Sensys 8639i W45 / 8639 W45 / 8669 W45
▶ For 45° face angles

24 - 29



Sensys W90 angle hinge
▶ Sensys 8639i W90 / 8639 W90 / 8669 W90
▶ For 90° face angles

30 - 33



Sensys aluminium frame hinge
▶ Sensys 8638i / 8638 / 8668
▶ For aluminium framed doors

34 - 37



Intermat corner unit hinge
▶ Intermat 9930
▶ For folding doors

38 - 39



Mounting plates
▶ System 8000 / 8099
▶ For Sensys and Intermat hinges

42 - 47



Accessories

48 - 50

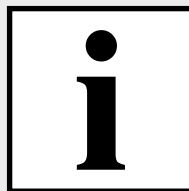

Technical information

52 - 59



Legend

CAD design data

- ▶ Available for downloading from www.hettich.com

Fast assembly concealed hinge with integrated Silent System



- ▶ Sensys 8645i
- ▶ 110° opening angle



- ▶ Concealed clip on hinge with integrated Silent System
- ▶ Quality classification in accordance with EN 15570, Level 3
- ▶ For door thickness of 15 - 24 mm
- ▶ Cup diameter 35 mm
- ▶ Cup depth 12.8 mm
- ▶ Integrated overlay adjustment + 2 mm / - 2 mm
- ▶ Integrated depth adjustment + 3 mm / - 2 mm
- ▶ Height adjustment at mounting plate
- ▶ Hinge arm material: nickel plated steel
- ▶ Hinge cup material: nickel plated steel

Sensys 8645i, 110° opening angle

Cup installation	Drilling pattern	Fixing hole ø x T mm	Full overlay	Half overlay	Inset	PU
			Basis B 12.5 mm	Basis B 3 mm	Basis B - 4 mm	
Screw on version TH 52		-	9 071 205	9 071 206	9 071 207	200 ea.
Press in version TH 53		ø 10 x 11	9 071 208	9 071 209	9 071 210	200 ea.
Flash fast assembly TH 54		ø 10 x 11	9 071 211	9 071 212	9 071 213	200 ea.
Fix fast assembly THS 55		ø 10 x 6	9 071 220	9 071 221	9 071 222	200 ea.
With prem. Euro screws TH 56		ø 5 x 11	9 071 214	9 071 215	9 071 216	200 ea.
Screw on version TB 52		-	9 071 223	9 071 224	9 071 225	200 ea.
Press in version TB 53		ø 8 x 11	9 071 226	9 071 227	9 071 228	200 ea.
Flash fast assembly TB 54		ø 8 x 11	9 071 229	9 071 230	9 071 231	200 ea.
Fix fast assembly TB 55		ø 8 x 6	9 071 238	9 071 239	9 071 240	200 ea.
With prem. Euro screws TH 56		ø 5 x 11	9 071 232	9 071 233	9 071 234	200 ea.



Fast assembly concealed hinge without integrated Silent System

- ▶ Sensys 8645
- ▶ 110° opening angle

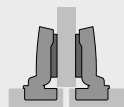

- ▶ Concealed clip on hinge without integrated Silent System
- ▶ Quality classification in accordance with EN 15570, Level 3
- ▶ For door thickness of 15 - 24 mm
- ▶ Cup diameter 35 mm
- ▶ Cup depth 12.8 mm
- ▶ Integrated overlay adjustment + 2 mm / - 2 mm
- ▶ Integrated depth adjustment + 3 mm / - 2 mm
- ▶ Height adjustment at mounting plate
- ▶ Hinge arm material: nickel plated steel
- ▶ Hinge cup material: nickel plated steel

Sensys 8645, 110° opening angle

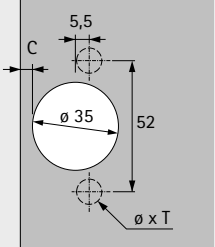
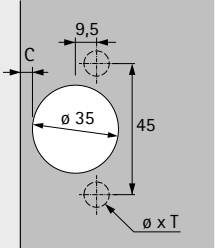
Cup installation	Drilling pattern	Fixing hole ø x T mm	Full overlay	Half overlay	Inset	PU
						
Screw on version TH 52		-	9 071 259	9 071 260	9 071 261	200 ea.
Press in version TH 53		ø 10 x 11	9 071 262	9 071 263	9 071 264	200 ea.
Fix fast assembly THS 55		ø 10 x 6	9 071 274	9 071 275	9 071 276	200 ea.
Screw on version TB 52		-	9 071 277	9 071 278	9 071 279	200 ea.
Press in version TB 53		ø 8 x 11	9 071 280	9 071 281	9 071 282	200 ea.
Fix fast assembly TB 55		ø 8 x 6	9 071 292	9 071 293	9 071 294	200 ea.



Fast assembly concealed hinge without automatic closing function

- ▶ Sensys 8675
- ▶ 110° opening angle

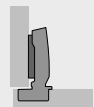
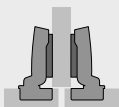

- ▶ Clip on hinge without automatic closing function
- ▶ For example, for Push to open applications
- ▶ Quality classification in accordance with EN 15570, Level 3
- ▶ For door thickness of 15 - 24 mm
- ▶ Cup diameter 35 mm
- ▶ Cup depth 12.8 mm
- ▶ Integrated overlay adjustment + 2 mm / - 2 mm
- ▶ Integrated depth adjustment + 3 mm / - 2 mm
- ▶ Height adjustment at mounting plate
- ▶ Hinge arm material: nickel plated steel
- ▶ Hinge cup material: nickel plated steel

Sensys 8675, 110° opening angle

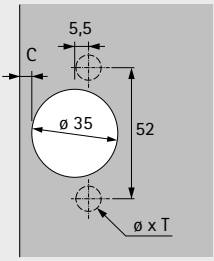
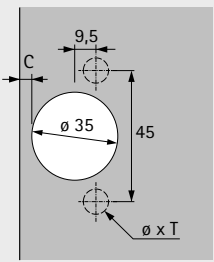
Cup installation	Drilling pattern	Fixing hole ø x T mm	Full overlay	Half overlay	Inset	PU
						
			Basis B 12.5 mm	Basis B 3 mm	Basis B - 4 mm	
Screw on version TH 52		-	9 071 313	9 071 314	9 071 315	200 ea.
Press in version TH 53		ø 10 x 11	9 071 316	9 071 317	9 071 318	200 ea.
Fix fast assembly THS 55		ø 10 x 6	9 071 328	9 071 329	9 071 330	200 ea.
Screw on version TB 52		-	9 071 331	9 071 332	9 071 333	200 ea.
Press in version TB 53		ø 8 x 11	9 071 334	9 071 335	9 071 336	200 ea.
Fix fast assembly TB 55		ø 8 x 6	9 071 346	9 071 347	9 071 348	200 ea.

Fast assembly concealed hinge

- ▶ Sensys 8645i / Sensys 8645 / Sensys 8675
- ▶ 110° opening angle

Minimum reveal per door

Door thickness mm	Cup distance C mm					
	3.0	4.0	4.5	5.0	6.0	7.0
15	0.2	0.2	0.2	0.2	0.2	0.2
16	0.3	0.3	0.3	0.3	0.3	0.3
17	0.4	0.4	0.4	0.4	0.4	0.4
18	0.6	0.6	0.6	0.6	0.6	0.5
19	0.8	0.8	0.8	0.8	0.7	0.7
20	1.1	1.0	1.0	1.0	1.0	0.9
21	1.4	1.3	1.3	1.3	1.2	1.2
22	2.2	1.8	1.7	1.6	1.6	1.5
23	3.0	2.6	2.4	2.2	2.0	1.9
24	3.9	3.4	3.2	3.0	2.6	2.4

Note:

The values in the table refer to doors with an edge radius of 1 mm.

On doors with other radii, the minimum reveal changes as follows:

Radius 0 mm:

Value in table + 0.4 mm

Radius 3 mm:

Value in table - 0.6 mm

Installation dimensions

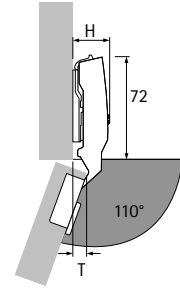

Hinge protrusion H / door protrusion T for distance D = 0 mm and cup distance C = 3 mm

Door mounting option	H mm	T mm
Full overlay	25.0	8.5
Half overlay	31.0	18.0
Inset	38.0	25.0

Full overlay

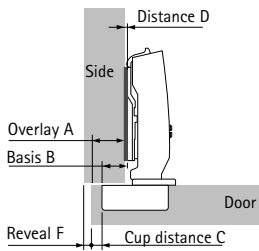

$$\text{Distance D} = \text{C} + \text{B} - \text{A}$$

$$= \text{cup distance C} + 12.5 \text{ mm} - \text{overlay A}$$

Overlay mm	Cup distance C mm					
	3.0	4.0	4.5	5.0	6.0	7.0
Distance D mm						
10	5.5	6.5	7.0	7.5	8.5	9.5
11	4.5	5.5	6.0	6.5	7.5	8.5
12	3.5	4.5	5.0	5.5	6.5	7.5
13	2.5	3.5	4.0	4.5	5.5	6.5
14	1.5	2.5	3.0	3.5	4.5	5.5
15	0.5	1.5	2.0	2.5	3.5	4.5
16		0.5	1.0	1.5	2.5	3.5
17			0.0	0.5	1.5	2.5
18					0.5	1.5
19						0.5

Half overlay

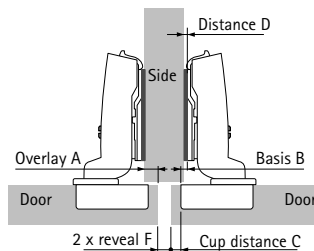

$$\text{Distance D} = \text{C} + \text{B} - \text{A}$$

$$= \text{cup distance C} + 3 \text{ mm} - \text{overlay A}$$

Overlay mm	Cup distance C mm					
	3.0	4.0	4.5	5.0	6.0	7.0
Distance D mm						
0.5	5.5	6.5	7.0	7.5	8.5	9.5
1.5	4.5	5.5	6.0	6.5	7.5	8.5
2.5	3.5	4.5	5.0	5.5	6.5	7.5
3.5	2.5	3.5	4.0	4.5	5.5	6.5
4.5	1.5	2.5	3.0	3.5	4.5	5.5
5.5	0.5	1.5	2.0	2.5	3.5	4.5
6.5		0.5	1.0	1.5	2.5	3.5
7.5			0.0	0.5	1.5	2.5
8.5					0.5	1.5
9.5						0.5

Inset

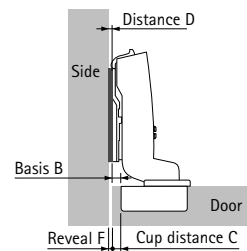

$$\text{Distance D} = \text{C} + \text{B} + \text{F}$$

$$= \text{cup distance C} - 4 \text{ mm} + \text{reveal F}$$

Door thickness mm	Cup distance C mm					
	3.0	4.0	4.5	5.0	6.0	7.0
Distance D mm						
15	0.2	0.7	1.2	2.2	3.2	
16	0.3	0.8	1.3	2.3	3.3	
17	0.4	0.9	1.4	2.4	3.4	
18	0.6	1.1	1.6	2.6	3.5	
19	0.8	1.3	1.8	2.7	3.7	
20	0.1	1.0	1.5	2.0	3.0	3.9
21	0.4	1.3	1.8	2.3	3.2	4.2
22	1.2	1.8	2.2	2.6	3.6	4.5
23	2.0	2.6	2.9	3.2	4.0	4.9
24	2.9	3.4	3.7	4.0	4.6	5.4

Advice

For mounting plates, see pages 42 - 47

For accessories, see pages 48 - 50

For technical information, see pages 52 - 59

Fast assembly concealed hinge with integrated Silent System

- ▶ Sensys 8631i for thick doors
- ▶ 95° opening angle



- ▶ Concealed clip on hinge with integrated Silent System
- ▶ Quality classification in accordance with EN 15570, Level 2
- ▶ For door thickness of 15 – 32 mm
- ▶ Cup diameter 35 mm
- ▶ Cup depth 12.8 mm
- ▶ Integrated overlay adjustment + 2 mm / - 2 mm
- ▶ Integrated depth adjustment + 3 mm / - 2 mm
- ▶ Height adjustment at mounting plate
- ▶ Hinge arm material: nickel plated steel
- ▶ Hinge cup material: nickel plated steel

Sensys 8631i, 95° opening angle

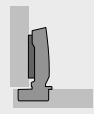
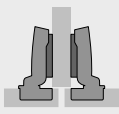
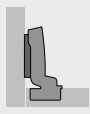
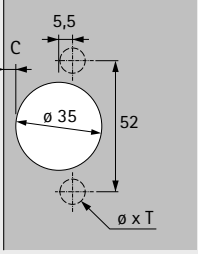
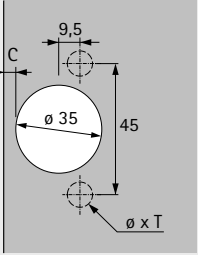
Cup installation	Drilling pattern	Fixing hole ø x T mm	Full overlay	Half overlay	Inset	PU
						
			Basis B 12.5 mm	Basis B 3 mm	Basis B - 4 mm	
Screw on version TH 52		-	9 090 260	9 090 270	9 090 280	200 ea.
Press in version TH 53		ø 10 x 11	9 090 261	9 090 271	9 090 281	200 ea.
Flash fast assembly TH 54		ø 10 x 11	9 090 262	9 090 272	9 090 282	200 ea.
With prem. Euro screws TH 56		ø 5 x 11	9 090 264	9 090 274	9 090 284	200 ea.
Screw on version TB 52		-	9 090 290	9 090 300	9 090 310	200 ea.
Press in version TB 53		ø 8 x 11	9 090 291	9 090 301	9 090 311	200 ea.
Flash fast assembly TB 54		ø 8 x 11	9 090 292	9 090 302	9 090 312	200 ea.
With prem. Euro screws TH 56		ø 5 x 11	9 090 294	9 090 304	9 090 314	200 ea.



Fast assembly concealed hinge without integrated Silent System

- ▶ Sensys 8631 for thick doors
- ▶ 95° opening angle

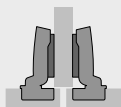

- ▶ Concealed clip on hinge without integrated Silent System
- ▶ Quality classification in accordance with EN 15570, Level 2
- ▶ For door thickness of 15 – 32 mm
- ▶ Cup diameter 35 mm
- ▶ Cup depth 12.8 mm
- ▶ Integrated overlay adjustment + 2 mm / - 2 mm
- ▶ Integrated depth adjustment + 3 mm / - 2 mm
- ▶ Height adjustment at mounting plate
- ▶ Hinge arm material: nickel plated steel
- ▶ Hinge cup material: nickel plated steel

Sensys 8631, 95° opening angle

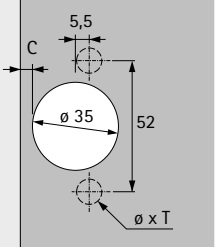
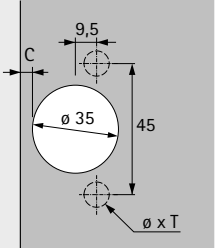
Cup installation	Drilling pattern	Fixing hole ø x T mm	Full overlay	Half overlay	Inset	PU
						
Screw on version TH 52		-	9 090 350	9 090 360	9 090 370	200 ea.
Press in version TH 53		ø 10 x 11	9 090 351	9 090 361	9 090 371	200 ea.
Screw on version TB 52		-	9 090 380	9 090 390	9 090 400	200 ea.
Press in version TB 53		ø 8 x 11	9 090 381	9 090 391	9 090 401	200 ea.

Fast assembly concealed hinge without automatic closing function

- ▶ Sensys 8661 for thick doors
- ▶ 95° opening angle



- ▶ Clip on hinge without automatic closing function
- ▶ For example, for Push to open applications
- ▶ Quality classification in accordance with EN 15570, Level 2
- ▶ For door thickness of 15 – 32 mm
- ▶ Cup diameter 35 mm
- ▶ Cup depth 12.8 mm
- ▶ Integrated overlay adjustment + 2 mm / - 2 mm
- ▶ Integrated depth adjustment + 3 mm / - 2 mm
- ▶ Height adjustment at mounting plate
- ▶ Hinge arm material: nickel plated steel
- ▶ Hinge cup material: nickel plated steel

Sensys 8661, 95° opening angle

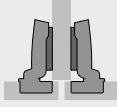
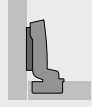
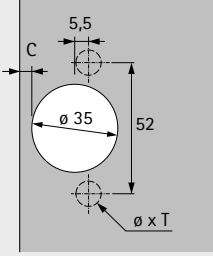
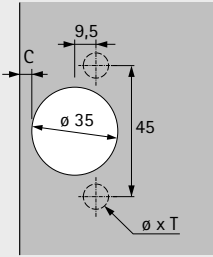
Cup installation	Drilling pattern	Fixing hole ø x T mm	Full overlay	Half overlay	Inset	PU
						
Screw on version TH 52		-	9 090 440	9 090 450	9 090 460	200 ea.
Press in version TH 53		ø 10 x 11	9 090 441	9 090 451	9 090 461	200 ea.
Screw on version TB 52		-	9 090 470	9 090 480	9 090 490	200 ea.
Press in version TB 53		ø 8 x 11	9 090 471	9 090 481	9 090 491	200 ea.

Fast assembly concealed hinge

- ▶ Sensys 8631i / Sensys 8631 / Sensys 8661 for thick doors
- ▶ 95° opening angle

Minimum reveal per door

Door thickness mm	Cup distance C mm							
	3.0	4.0	4.5	5.0	6.0	7.0	8.0	
15	0.1	0.1	0.1	0.1	0.1	0.1	0.1	
16	0.1	0.1	0.1	0.1	0.1	0.1	0.1	
17	0.2	0.2	0.2	0.2	0.2	0.2	0.2	
18	0.2	0.2	0.2	0.2	0.2	0.2	0.2	
19	0.3	0.3	0.3	0.3	0.3	0.3	0.3	
20	0.4	0.4	0.4	0.4	0.4	0.4	0.4	
21	0.6	0.6	0.6	0.6	0.6	0.6	0.6	
22	0.7	0.7	0.7	0.7	0.7	0.7	0.7	
23	0.9	0.9	0.9	0.9	0.9	0.9	0.9	
24	1.1	1.0	1.0	1.0	1.0	1.0	1.0	
25	1.3	1.2	1.2	1.2	1.2	1.2	1.2	
26	1.5	1.5	1.4	1.4	1.4	1.4	1.4	
27	1.7	1.7	1.7	1.7	1.6	1.6	1.6	
28	2.0	2.0	1.9	1.9	1.9	1.8	1.8	
29	2.9	2.3	2.2	2.2	2.2	2.1	2.1	
30	3.8	3.2	3.0	2.7	2.5	2.4	2.4	
31	4.8	4.1	3.8	3.6	3.1	2.7	2.7	
32	5.7	5.1	4.8	4.5	3.9	3.4	3.0	

Note:

The values in the table refer to doors with an edge radius of 1 mm.

On doors with other radii, the minimum reveal changes as follows:

Radius 0 mm:
Value in table + 0.4 mm

Installation dimensions

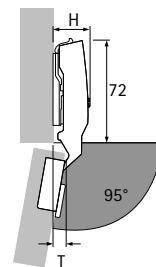

Hinge protrusion H / door protrusion T for distance D = 0 mm and cup distance C = 3 mm

Door mounting option	H mm	T mm
Full overlay	24.0	12.5
Half overlay	28.3	22.0
Inset	35.3	29.0

Full overlay

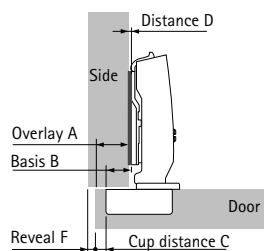

$$\text{Distance D} = \text{C} + \text{B} - \text{A}$$

$$= \text{cup distance C} + 12.5 \text{ mm} - \text{overlay A}$$

Overlay mm	Cup distance C mm							
	3.0	4.0	4.5	5.0	6.0	7.0	8.0	
	Distance D mm							
10	5.5	6.5	7.0	7.5	8.5	9.5	10.5	
11	4.5	5.5	6.0	6.5	7.5	8.5	9.5	
12	3.5	4.5	5.0	5.5	6.5	7.5	8.5	
13	2.5	3.5	4.0	4.5	5.5	6.5	7.5	
14	1.5	2.5	3.0	3.5	4.5	5.5	6.5	
15	0.5	1.5	2.0	2.5	3.5	4.5	5.5	
16		0.5	1.0	1.5	2.5	3.5	4.5	
17			0.0	0.5	1.5	2.5	3.5	
18					0.5	1.5	2.5	
19						0.5	1.5	
20							0.5	

Half overlay

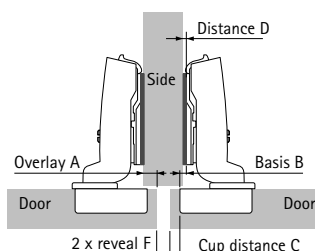

$$\text{Distance D} = \text{C} + \text{B} - \text{A}$$

$$= \text{cup distance C} + 3 \text{ mm} - \text{overlay A}$$

Overlay mm	Cup distance C mm							
	3.0	4.0	4.5	5.0	6.0	7.0	8.0	
	Distance D mm							
0.5	5.5	6.5	7.0	7.5	8.5	9.5	10.5	
1.5	4.5	5.5	6.0	6.5	7.5	8.5	9.5	
2.5	3.5	4.5	5.0	5.5	6.5	7.5	8.5	
3.5	2.5	3.5	4.0	4.5	5.5	6.5	7.5	
4.5	1.5	2.5	3.0	3.5	4.5	5.5	6.5	
5.5	0.5	1.5	2.0	2.5	3.5	4.5	5.5	
6.5		0.5	1.0	1.5	2.5	3.5	4.5	
7.5			0.0	0.5	1.5	2.5	3.5	
8.5					0.5	1.5	2.5	
9.5						0.5	1.5	
10.5							0.5	

Inset

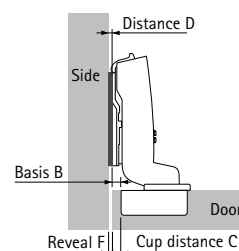

$$\text{Distance D} = \text{C} + \text{B} + \text{F}$$

$$= \text{cup distance C} - 4 \text{ mm} + \text{reveal F}$$

Door thickness mm	Cup distance C mm							
	3.0	4.0	4.5	5.0	6.0	7.0	8.0	
	Distance D mm							
15	0.1	0.6	1.1	2.1	3.1	4.1		
16	0.1	0.6	1.1	2.1	3.1	4.1		
17	0.2	0.7	1.2	2.2	3.2	4.2		
18	0.2	0.7	1.2	2.2	3.2	4.2		
19	0.3	0.8	1.3	2.3	3.3	4.3		
20	0.4	0.9	1.4	2.4	3.4	4.4		
21	0.6	1.1	1.6	2.6	3.6	4.6		
22	0.7	1.2	1.7	2.7	3.7	4.7		
23	0.9	1.4	1.9	2.9	3.9	4.9		
24	0.1	1.0	1.5	2.0	3.0	4.0	5.0	
25	0.3	1.2	1.7	2.2	3.2	4.2	5.2	
26	0.5	1.5	1.9	2.4	3.4	4.4	5.4	
27	0.7	1.7	2.2	2.7	3.6	4.6	5.6	
28	1.0	2.0	2.4	2.9	3.9	4.8	5.8	
29	1.9	2.3	2.7	3.2	4.2	5.1	6.1	
30	2.8	3.2	3.5	3.7	4.5	5.4	6.4	
31	3.8	4.1	4.3	4.6	5.1	5.7	6.7	
32	4.7	5.1	5.3	5.5	5.9	6.4	7.0	

Advice

- For mounting plates, see pages 42 - 47
- For accessories, see pages 48 - 50
- For technical information, see pages 52 - 59
- For example applications, see page 52 - 53

Fast assembly concealed hinge

- ▶ Sensys 8631i / Sensys 8631 / Sensys 8661 for thick doors
- ▶ Opening angle 95°

Door contours for minimum reveal application - scale 1:1

The values shown in the Minimum reveal table refer to an edge radius of 1 mm. Smaller reveal values apply if door edges are more rounded. To obtain a minimum reveal application, the chosen door contour must lie within the template illustrated below. All contours protruding beyond the template will increase the reveal accordingly.

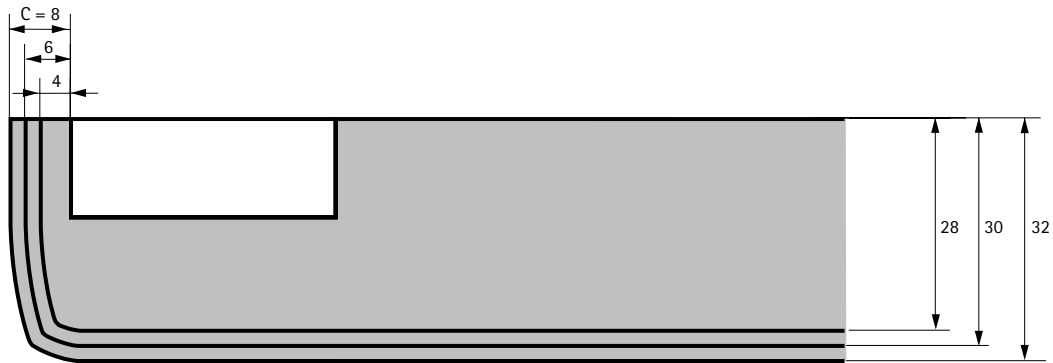

Examples of minimum reveal application

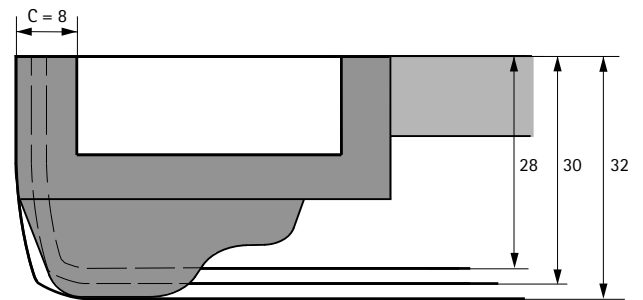
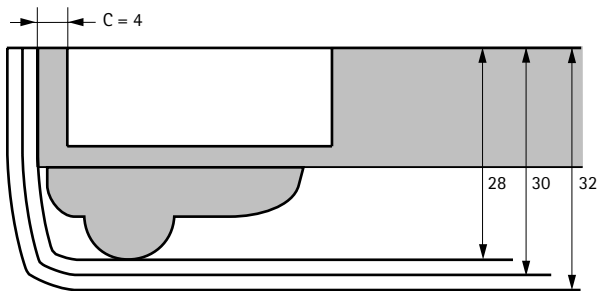

Example of minimum reveal application

Door thickness	16 mm
Profile thickness	12 mm
Overall thickness	28 mm
Cup distance C	4 mm

Example of minimum reveal application

Door thickness	19 mm
Profile thickness	13 mm
Overall thickness	32 mm
Cup distance C	8 mm

Fast assembly concealed hinge with integrated Silent System

- ▶ Sensys 8657i, zero protrusion hinge
- ▶ 165° opening angle



- ▶ Concealed clip on hinge with integrated Silent System
- ▶ Quality classification in accordance with EN 15570, Level 3
- ▶ For door thickness of 15 – 32 mm
- ▶ Cup diameter 35 mm
- ▶ Cup depth 11.6 mm
- ▶ Integrated overlay adjustment + 2 mm / - 2 mm
- ▶ Integrated depth adjustment + 3 mm / - 2 mm
- ▶ Height adjustment at mounting plate
- ▶ Opening angle can be reduced by means of optional accessory
- ▶ Zero protrusion hinge
- ▶ Hinge arm material: nickel plated steel
- ▶ Hinge cup material: nickel plated steel

Sensys 8657i, 165° opening angle

Cup installation	Drilling pattern	Fixing hole ø x T mm	Full overlay	Half overlay	PU
			Basis B 12.5 mm	Basis B 3 mm	
Screw on version TH 52		-	9 099 540	9 099 550	50 ea.
Press in version TH 53		ø 10 x 11	9 099 541	9 099 551	50 ea.
Flash fast assembly TH 54		ø 10 x 11	9 099 542	9 099 552	50 ea.
Fix fast assembly THS 55		ø 10 x 6	9 099 543	9 099 553	50 ea.
With prem. Euro screws TH 56		ø 5 x 11	9 099 544	9 099 554	50 ea.
Screw on version TB 52		-	9 099 560	9 099 570	50 ea.
Press in version TB 53		ø 8 x 11	9 099 561	9 099 571	50 ea.
Flash fast assembly TB 54		ø 8 x 11	9 099 562	9 099 572	50 ea.
Fix fast assembly TB 55		ø 8 x 6	9 099 563	9 099 573	50 ea.
With prem. Euro screws TH 56		ø 5 x 11	9 099 564	9 099 574	50 ea.

Fast assembly concealed hinge without integrated Silent System

- ▶ Sensys 8657, zero protrusion hinge
- ▶ 165° opening angle



- ▶ Concealed clip on hinge without integrated Silent System
- ▶ Quality classification in accordance with EN 15570, Level 3
- ▶ For door thickness of 15 – 32 mm
- ▶ Cup diameter 35 mm
- ▶ Cup depth 11.6 mm
- ▶ Integrated overlay adjustment + 2 mm / - 2 mm
- ▶ Integrated depth adjustment +3 mm / - 2 mm
- ▶ Height adjustment at mounting plate
- ▶ Opening angle can be reduced by means of optional accessory
- ▶ Zero protrusion hinge
- ▶ Hinge arm material: nickel plated steel
- ▶ Hinge cup material: nickel plated steel

Sensys 8657, 165° opening angle

Cup installation	Drilling pattern	Fixing hole ø x T mm	Full overlay	Half overlay	PU
			Basis B 12.5 mm	Basis B 3 mm	
Screw on version TH 52		-			50 ea.
Press in version TH 53		ø 10 x 11	9 099 601	9 099 611	50 ea.
Fix fast assembly THS 55		ø 10 x 6	9 099 603	9 099 613	50 ea.
Screw on version TB 52		-	9 099 620	9 099 630	50 ea.
Press in version TB 53		ø 8 x 11	9 099 621	9 099 631	50 ea.
Fix fast assembly TB 55		ø 8 x 6	9 099 623	9 099 633	50 ea.



Fast assembly concealed hinge without automatic closing function

- ▶ Sensys 8687, zero protrusion hinge
- ▶ 165° opening angle



- ▶ Clip on hinge without automatic closing function
- ▶ For example, for Push to open applications
- ▶ Quality classification in accordance with EN 15570, Level 3
- ▶ For door thickness of 15 – 32 mm
- ▶ Cup diameter 35 mm
- ▶ Cup depth 11.6 mm
- ▶ Integrated overlay adjustment + 2 mm / - 2 mm
- ▶ Integrated depth adjustment + 3 mm / - 2 mm
- ▶ Height adjustment at mounting plate
- ▶ Opening angle can be reduced by means of optional accessory
- ▶ Zero protrusion hinge
- ▶ Hinge arm material: nickel plated steel
- ▶ Hinge cup material: nickel plated steel

Sensys 8687, 165° opening angle

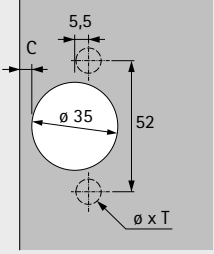
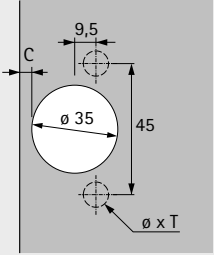
Cup installation	Drilling pattern	Fixing hole ø x T mm	Full overlay	Half overlay	PU
					
			Basis B 12.5 mm	Basis B 3 mm	
Screw on version TH 52		-	9 099 660	9 099 670	50 ea.
Press in version TH 53		ø 10 x 11	9 099 661	9 099 671	50 ea.
Fix fast assembly THS 55		ø 10 x 6	9 099 663	9 099 673	50 ea.
Screw on version TB 52		-	9 099 680	9 099 690	50 ea.
Press in version TB 53		ø 8 x 11	9 099 681	9 099 691	50 ea.
Fix fast assembly TB 55		ø 8 x 6	9 099 683	9 099 693	50 ea.

Fast assembly concealed hinge

- ▶ Sensys 8657i / Sensys 8657 / Sensys 8687, zero protrusion hinge
- ▶ 165° opening angle

Minimum reveal per door

Door thickness mm	Cup distance C mm					
	3.0	4.0	4.5	5.0	6.0	7.0
15	0.0	0.0	0.0	0.0	0.0	0.0
16	0.0	0.0	0.0	0.0	0.0	0.0
17	0.0	0.0	0.0	0.0	0.0	0.0
18	0.0	0.0	0.0	0.0	0.0	0.0
19	0.0	0.0	0.0	0.0	0.0	0.0
20	0.0	0.0	0.0	0.0	0.0	0.0
21	0.0	0.0	0.0	0.0	0.0	0.0
22	0.0	0.0	0.0	0.0	0.0	0.0
23	0.0	0.0	0.0	0.0	0.0	0.0
24	0.0	0.0	0.0	0.0	0.0	0.0
25	0.0	0.0	0.0	0.0	0.0	0.0
26	0.1	0.1	0.1	0.1	0.1	0.1
27	0.1	0.1	0.1	0.1	0.1	0.1
28	0.2	0.2	0.2	0.2	0.2	0.3
29*	0.4	0.4	0.4	0.4	0.5	0.6
30*	0.7	0.7	0.8	0.8	1.0	1.1
31**	1.1	1.2	1.3	1.4	1.6	
32**	1.7	1.9	2.0	2.2		

*when using the opening angle limiter at 120°
 ** when using the opening angle limiter at 105°

Installation dimensions

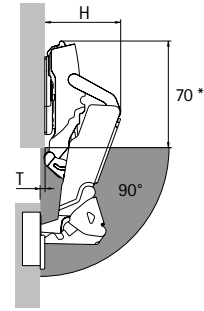

No door protrusion T up to distance D = 3.0, unobstructed interior for pull-outs
 *Hinge closed: 80 mm

Door mounting option	H mm (max. at 30°)	T mm (90°, D0)
Full overlay	66	-3
Half overlay	75.5	6.5

Full overlay

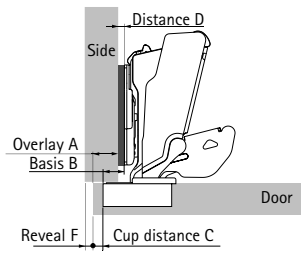

$$\text{Distance D} = \text{C} + \text{B} - \text{A}$$

$$= \text{cup distance C} + 12.5 \text{ mm} - \text{overlay A}$$

Overlay mm	Cup distance C mm					
	3.0	4.0	4.5	5.0	6.0	7.0
Distance D mm						
10	5.5	6.5	7.0	7.5	8.5	9.5
11	4.5	5.5	6.0	6.5	7.5	8.5
12	3.5	4.5	5.0	5.5	6.5	7.5
13	2.5	3.5	4.0	4.5	5.5	6.5
14	1.5	2.5	3.0	3.5	4.5	5.5
15	0.5	1.5	2.0	2.5	3.5	4.5
16		0.5	1.0	1.5	2.5	3.5
17			0.0	0.5	1.5	2.5
18					0.5	1.5
19						0.5

Half overlay

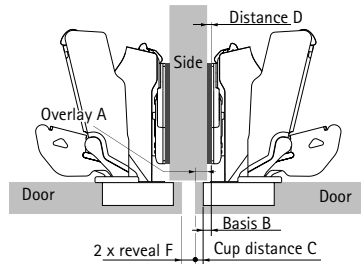

$$\text{Distance D} = \text{C} + \text{B} - \text{A}$$

$$= \text{cup distance C} + 3 \text{ mm} - \text{overlay A}$$

Overlay mm	Cup distance C mm					
	3.0	4.0	4.5	5.0	6.0	7.0
Distance D mm						
- 2	8.0	9.0	9.5	10.0	11.0	12.0
- 1	7.0	8.0	8.5	9.0	10.0	11.0
0	6.0	7.0	7.5	8.0	9.0	10.0
1	5.0	6.0	6.5	7.0	8.0	9.0
2	4.0	5.0	5.5	6.0	7.0	8.0
3	3.0	4.0	4.5	5.0	6.0	7.0
4	2.0	3.0	3.5	4.0	5.0	6.0
5	1.0	2.0	2.5	3.0	4.0	5.0
6	0.0	1.0	1.5	2.0	3.0	4.0
7		0.0	0.5	1.0	2.0	3.0
8				0.0	1.0	2.0
9					0.0	1.0
10						0.0

Advice

- For mounting plates, see pages 42 - 47
- For accessories, see pages 48 - 50
- For technical information, see pages 52 - 59



Fast assembly concealed hinge with integrated Silent System

- ▶ Sensys 8639i W30
- ▶ For 30° face angles, 95° opening angle



- ▶ Concealed clip on hinge with integrated Silent System
- ▶ Quality classification in accordance with EN 15570, Level 3
- ▶ For diagonal cabinets, carcase angle 120°
- ▶ For door thickness of 15 - 28 mm
- ▶ Cup diameter 35 mm
- ▶ Cup depth 12.8 mm
- ▶ Integrated overlay adjustment + 2 mm / - 2 mm
- ▶ Integrated depth adjustment + 3 mm / - 2 mm
- ▶ Height adjustment at mounting plate
- ▶ Hinge arm material: nickel plated die cast zinc
- ▶ Hinge cup material: nickel plated steel

Sensys 8639i W30, 95° opening angle

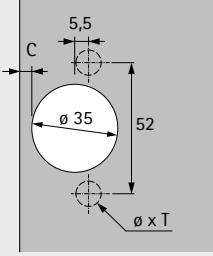
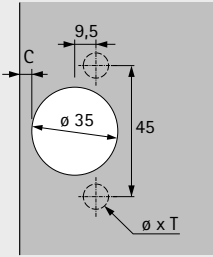
Cup installation	Drilling pattern	Fixing hole ø x T mm	Overlay	Inset	PU
					
			Basis B 2 mm	Basis B - 16 mm	
Screw on version TH 52		-	9 085 166	9 085 167	200 ea.
Press in version TH 53		ø 10 x 11	9 085 171	9 085 172	200 ea.
Flash fast assembly TH 54		ø 10 x 11	9 085 176	9 085 177	200 ea.
Fix fast assembly THS 55		ø 10 x 6	9 085 336	9 085 337	200 ea.
With prem. Euro screws TH 56		ø 5 x 11	9 085 181	9 085 182	200 ea.
Screw on version TB 52		-	9 085 191	9 085 192	200 ea.
Press in version TB 53		ø 8 x 11	9 085 196	9 085 197	200 ea.
Flash fast assembly TB 54		ø 8 x 11	9 085 201	9 085 202	200 ea.
Fix fast assembly TB 55		ø 8 x 6	9 085 341	9 085 342	200 ea.
With prem. Euro screws TH 56		ø 5 x 11	9 085 206	9 085 207	200 ea.



Fast assembly concealed hinge without integrated Silent System

- ▶ Sensys 8639 W30
- ▶ For 30° face angles, 95° opening angle



- ▶ Concealed clip on hinge without integrated Silent System
- ▶ Quality classification in accordance with EN 15570, Level 3
- ▶ For diagonal cabinets, carcass angle 120°
- ▶ For door thickness of 15 - 28 mm
- ▶ Cup diameter 35 mm
- ▶ Cup depth 12.8 mm
- ▶ Integrated overlay adjustment + 2 mm / - 2 mm
- ▶ Integrated depth adjustment + 3 mm / - 2 mm
- ▶ Height adjustment at mounting plate
- ▶ Hinge arm material: nickel plated die cast zinc
- ▶ Hinge cup material: nickel plated steel

Sensys 8639 W30, 95° opening angle

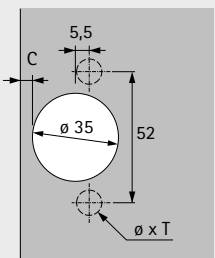
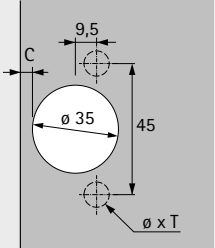
Cup installation	Drilling pattern	Fixing hole ø x T mm	Overlay	Inset	PU
					
Screw on version TH 52		-	Basis B 2 mm	Basis B - 16 mm	200 ea.
Press in version TH 53		ø 10 x 11	9 085 216	9 085 217	200 ea.
Fix fast assembly THS 55		ø 10 x 6	9 085 221	9 085 222	200 ea.
Fix fast assembly TB 55		ø 8 x 6	9 085 381	9 085 382	200 ea.
			9 085 386	9 085 387	200 ea.



Fast assembly concealed hinge without automatic closing function

- ▶ Sensys 8669 W30
- ▶ For 30° face angles, 95° opening angle



- ▶ Clip on hinge without automatic closing function
- ▶ For example, for Push to open applications
- ▶ Quality classification in accordance with EN 15570, Level 3
- ▶ For diagonal cabinets, carcase angle 120°
- ▶ For door thickness of 15 - 28 mm
- ▶ Cup diameter 35 mm
- ▶ Cup depth 12.8 mm
- ▶ Integrated overlay adjustment + 2 mm / - 2 mm
- ▶ Integrated depth adjustment + 3 mm / - 2 mm
- ▶ Height adjustment at mounting plate
- ▶ Hinge arm material: nickel plated die cast zinc
- ▶ Hinge cup material: nickel plated steel

Sensys 8669 W30, 95° opening angle

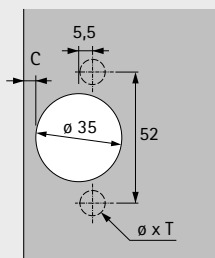
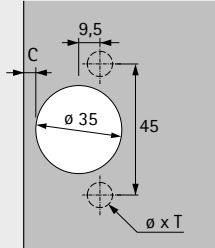
Cup installation	Drilling pattern	Fixing hole ø x T mm	Overlay	Inset	PU
					
Screw on version TH 52		-	Basis B 2 mm	Basis B - 16 mm	200 ea.
Press in version TH 53		ø 10 x 11	9 085 271	9 085 272	200 ea.
Fix fast assembly THS 55		ø 10 x 6	9 085 426	9 085 427	200 ea.
Fix fast assembly TB 55		ø 8 x 6	9 085 431	9 085 432	200 ea.

Fast assembly concealed hinge

- ▶ Sensys 8639i W30 / Sensys 8639 W30 / Sensys 8669 W30
- ▶ For 30° face angles, 95° opening angle

Minimum reveal per door

Door thickness mm	Cup distance C mm							
	3.0	4.0	4.5	5.0	6.0	7.0	8.0	
15	0.2	0.2	0.2	0.2	0.2	0.2	0.2	
16	0.3	0.3	0.3	0.3	0.3	0.3	0.3	
17	0.4	0.4	0.4	0.4	0.4	0.4	0.4	
18	0.6	0.6	0.6	0.6	0.6	0.5	0.5	
19	0.8	0.8	0.8	0.8	0.7	0.7	0.7	
20	1.1	1.0	1.0	1.0	1.0	0.9	0.9	
21	1.4	1.3	1.3	1.3	1.2	1.2	1.2	
22	2.2	1.8	1.7	1.6	1.6	1.5	1.4	
23	3.0	2.6	2.4	2.2	2.0	1.9	1.8	
24	3.9	3.4	3.2	3.0	2.6	2.4	2.2	
25	4.8	4.2	4.0	3.8	3.4	3.0	2.8	
26	5.7	5.1	4.8	4.6	4.2	3.8	3.4	
27	6.6	6.0	5.7	5.5	5.0	4.5	4.2	
28	7.5	6.9	6.6	6.3	5.8	5.3	4.9	

Note:

The values in the table refer to doors with an edge radius of 1 mm.

On doors with other radii, the minimum reveal changes as follows:

- Radius 0 mm: Value in table + 0.4 mm
- Radius 3 mm: Value in table - 0.6 mm

Note

The drawings below show the hinges including mounting plate distances on a scale of 1:1. Allowing for cup distance C (3 - 8 mm) as well as the minimum reveal, the required mounting plate distance and hole line can be determined by drawing in the door and side panel.

You can visit our Hettich channel on YouTube for further information on how to configure cabinets.

Overlay (B 2 mm) - scale 1:1

$$\text{Distance D} = 0.87 \times (C + B - A)$$

$$= 0.87 \times (\text{cup distance C} + 2 \text{ mm} - \text{overlay A})$$

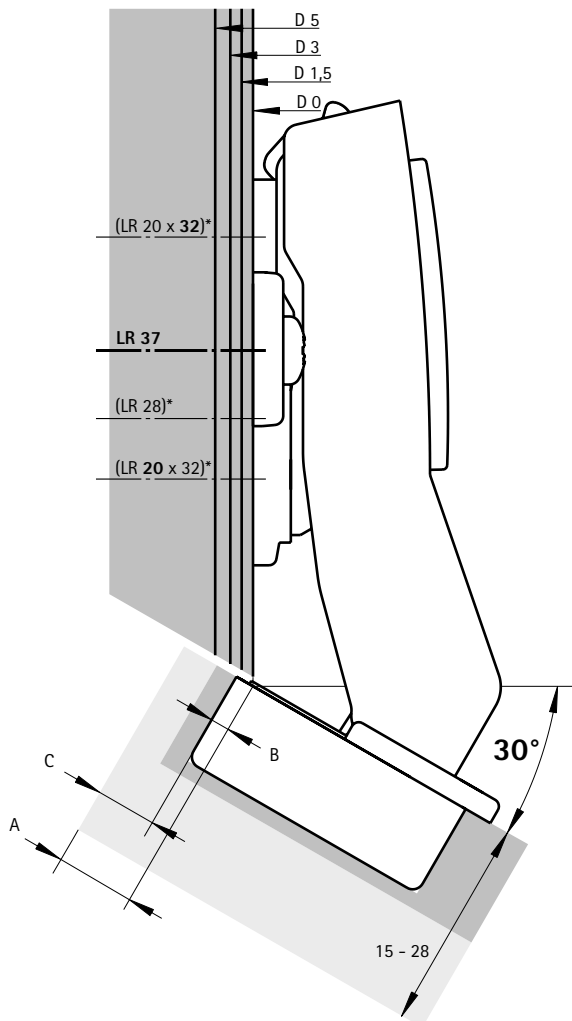

Inset (B -16 mm) - scale 1:1

$$\text{Distance D} = 0.87 \times (C + B + F)$$

$$= 0.87 \times (\text{cup distance C} - 16 \text{ mm} + \text{reveal F})$$

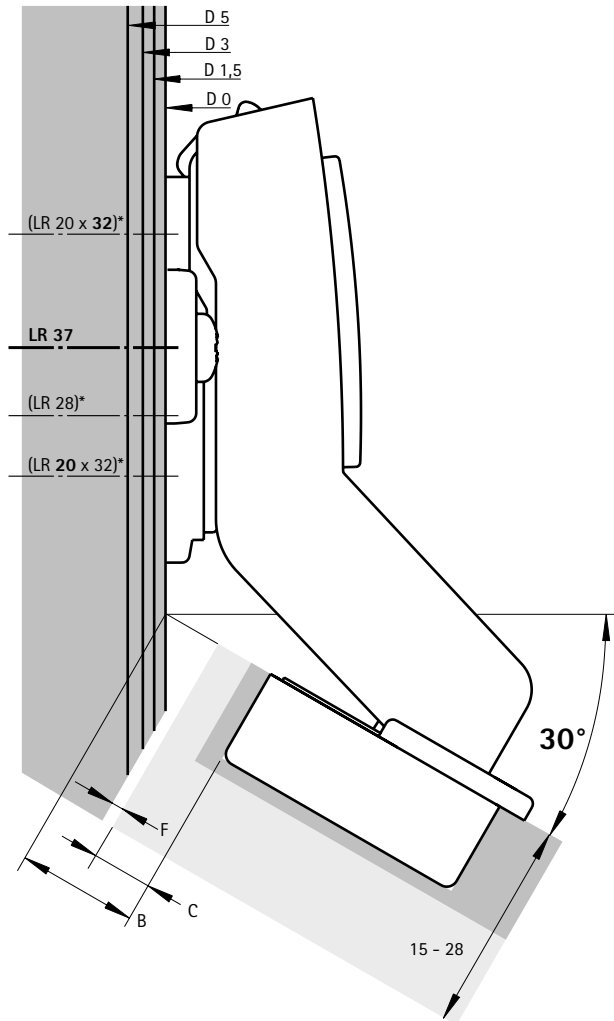

▶ Advice

*not available on all markets
 For mounting plates and accessories, see page 42 - 50
 For example applications and technical information, see pages 52 - 59



Fast assembly concealed hinge with integrated Silent System

- ▶ Sensys 8639i W45
- ▶ For 45° face angles, 95° opening angle



- ▶ Concealed clip on hinge with integrated Silent System
- ▶ Quality classification in accordance with EN 15570, Level 3
- ▶ For diagonal cabinets, carcass angle 135°
- ▶ For door thickness of 15 - 28 mm
- ▶ Cup diameter 35 mm
- ▶ Cup depth 12.8 mm
- ▶ Integrated overlay adjustment + 2 mm / - 2 mm
- ▶ Integrated depth adjustment + 3 mm / - 2 mm
- ▶ Height adjustment at mounting plate
- ▶ Hinge arm material: nickel plated die cast zinc
- ▶ Hinge cup material: nickel plated steel

Sensys 8639i W45, 95° opening angle

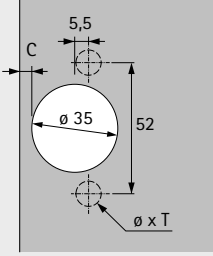
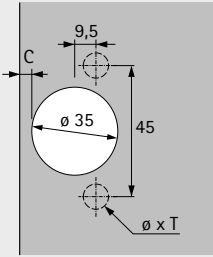
Cup installation	Drilling pattern	Fixing hole ø x T mm	Overlay	Overlay	Inset	PU
						
			Basis B 9 mm	Basis B - 2 mm	Basis B - 25 mm	
Screw on version TH 52		-	9 090 748	9 085 168	9 085 169	200 ea.
Press in version TH 53		ø 10 x 11	9 090 749	9 085 173	9 085 174	200 ea.
Flash fast assembly TH 54		ø 10 x 11	9 091 017	9 085 178	9 085 179	200 ea.
Fix fast assembly THS 55		ø 10 x 6	9 091 027	9 085 338	9 085 339	200 ea.
With prem. Euro screws TH 56		ø 5 x 11	9 091 018	9 085 183	9 085 184	200 ea.
Screw on version TB 52		-	9 091 019	9 085 193	9 085 194	200 ea.
Press in version TB 53		ø 8 x 11	9 091 020	9 085 198	9 085 199	200 ea.
Flash fast assembly TB 54		ø 8 x 11	9 091 021	9 085 203	9 085 204	200 ea.
Fix fast assembly TB 55		ø 8 x 6	9 091 028	9 085 343	9 085 344	200 ea.
With prem. Euro screws TH 56		ø 5 x 11	9 091 022	9 085 208	9 085 209	200 ea.



Fast assembly concealed hinge without integrated Silent System

- ▶ Sensys 8639 W45
- ▶ For 45° face angles, 95° opening angle



- ▶ Concealed clip on hinge without integrated Silent System
- ▶ Quality classification in accordance with EN 15570, Level 3
- ▶ For diagonal cabinets, carcase angle 135°
- ▶ For door thickness of 15 - 28 mm
- ▶ Cup diameter 35 mm
- ▶ Cup depth 12.8 mm
- ▶ Integrated overlay adjustment + 2 mm / - 2 mm
- ▶ Integrated depth adjustment + 3 mm / - 2 mm
- ▶ Height adjustment at mounting plate
- ▶ Hinge arm material: nickel plated die cast zinc
- ▶ Hinge cup material: nickel plated steel

Sensys 8639 W45, 95° opening angle

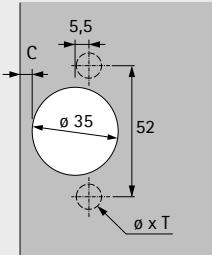
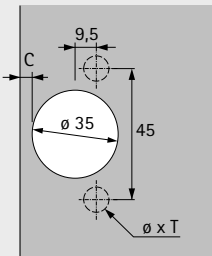
Cup installation	Drilling pattern	Fixing hole ø x T mm	Overlay	Overlay	Inset	PU
						
			Basis B 9 mm	Basis B - 2 mm	Basis B - 25 mm	
Screw on version TH 52		-	9 091 029	9 085 218	9 085 219	200 ea.
Press in version TH 53		ø 10 x 11	9 091 030	9 085 223	9 085 224	200 ea.
Fix fast assembly THS 55		ø 10 x 6	9 091 041	9 085 383	9 085 384	200 ea.
Fix fast assembly TB 55		ø 8 x 6	9 091 042	9 085 388	9 085 389	200 ea.

Fast assembly concealed hinge without automatic closing function

- ▶ Sensys 8669 W45
- ▶ For 45° face angles, 95° opening angle



- ▶ Clip on hinge without automatic closing function
- ▶ For example, for Push to open applications
- ▶ Quality classification in accordance with EN 15570, Level 3
- ▶ For diagonal cabinets, carcass angle 135°
- ▶ For door thickness of 15 - 28 mm
- ▶ Cup diameter 35 mm
- ▶ Cup depth 12.8 mm
- ▶ Integrated overlay adjustment + 2 mm / - 2 mm
- ▶ Integrated depth adjustment + 3 mm / - 2 mm
- ▶ Height adjustment at mounting plate
- ▶ Hinge arm material: nickel plated die cast zinc
- ▶ Hinge cup material: nickel plated steel

Sensys 8669 W45, 95° opening angle

Cup installation	Drilling pattern	Fixing hole ø x T mm	Overlay	Overlay	Inset	PU
Screw on version TH 52		-	Basis B 9 mm	Basis B - 2 mm	Basis B - 25 mm	200 ea.
Press in version TH 53		ø 10 x 11	9 091 058	9 085 268	9 085 269	200 ea.
Fix fast assembly THS 55		ø 10 x 6	9 091 059	9 085 273	9 085 274	200 ea.
Fix fast assembly TB 55		ø 8 x 6	9 091 074	9 085 428	9 085 429	200 ea.
			9 091 075	9 085 433	9 085 434	200 ea.

Fast assembly concealed hinge

- ▶ Sensys 8639i W45 / Sensys 8639 W45 / Sensys 8669 W45
- ▶ For 45° face angles, 95° opening angle

Minimum reveal per door

Door thickness mm	Cup distance C mm							
	3.0	4.0	4.5	5.0	6.0	7.0	8.0	
15	0.2	0.2	0.2	0.2	0.2	0.2	0.2	
16	0.3	0.3	0.3	0.3	0.3	0.3	0.3	
17	0.4	0.4	0.4	0.4	0.4	0.4	0.4	
18	0.6	0.6	0.6	0.6	0.6	0.5	0.5	
19	0.8	0.8	0.8	0.8	0.7	0.7	0.7	
20	1.1	1.0	1.0	1.0	1.0	0.9	0.9	
21	1.4	1.3	1.3	1.3	1.2	1.2	1.2	
22	2.2	1.8	1.7	1.6	1.6	1.5	1.4	
23	3.0	2.6	2.4	2.2	2.0	1.9	1.8	
24	3.9	3.4	3.2	3.0	2.6	2.4	2.2	
25	4.8	4.2	4.0	3.8	3.4	3.0	2.8	
26	5.7	5.1	4.8	4.6	4.2	3.8	3.4	
27	6.6	6.0	5.7	5.5	5.0	4.5	4.2	
28	7.5	6.9	6.6	6.3	5.8	5.3	4.9	

Note:

The values in the table refer to doors with an edge radius of 1 mm.

On doors with other radii, the minimum reveal changes as follows:

Radius 0 mm:

Value in table + 0.4 mm

Radius 3 mm:

Value in table - 0.6 mm

Note

The drawings below show the hinges including mounting plate distances on a scale of 1:1.

Allowing for cup distance C (3 - 8 mm) as well as the minimum reveal, the required mounting plate distance and hole line can be determined by drawing in the door and side panel.

You can visit our Hettich channel on YouTube for further information on how to configure cabinets.

Overlay (B 9 mm) - scale 1:1

$$\text{Distance D} = 0.71 \times (C + B - A)$$

$$= 0.71 \times (\text{cup distance C} + 9 \text{ mm} - \text{overlay A})$$

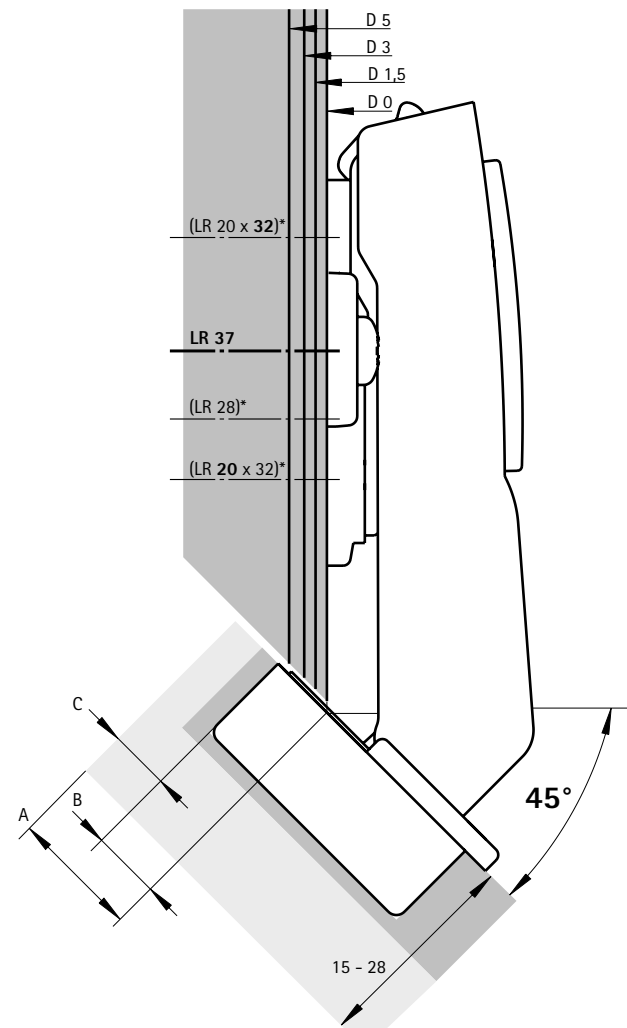

Overlay (B -2 mm) - scale 1:1

$$\text{Distance D} = 0.71 \times (C + B - A)$$

$$= 0.71 \times (\text{cup distance C} + 2 \text{ mm} - \text{overlay A})$$

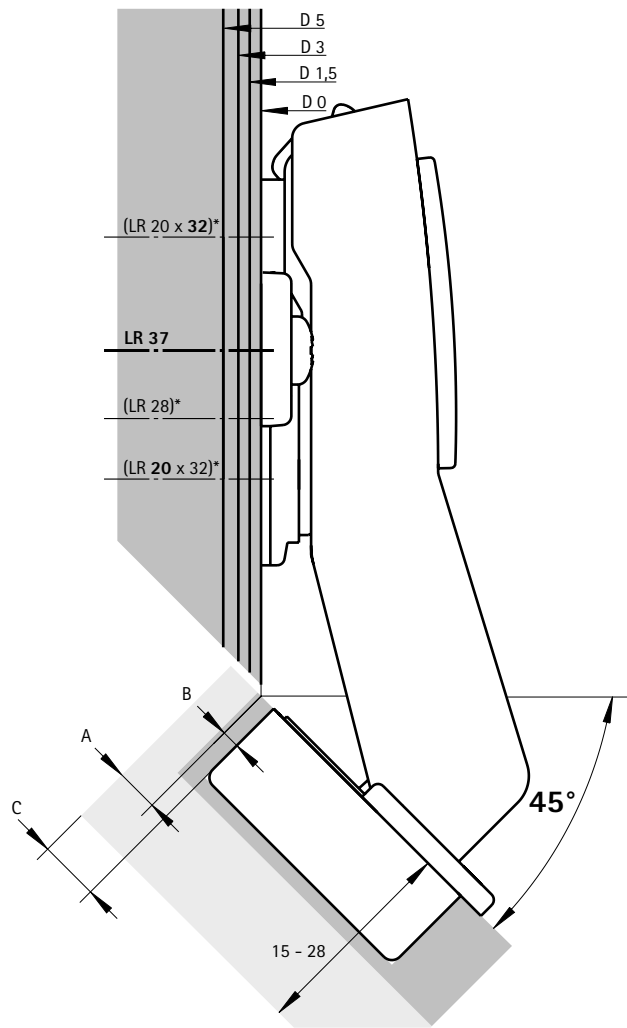

▶ Advice

*not available on all markets

For mounting plates and accessories, see page 42 - 50

For example applications and technical information, see pages 52 - 59

Fast assembly concealed hinge

- ▶ Sensys 8639i W45 / Sensys 8639 W45 / Sensys 8669 W45
- ▶ For 45° face angles, 95° opening angle

Minimum reveal per door

Door thickness mm	Cup distance C mm							
	3.0	4.0	4.5	5.0	6.0	7.0	8.0	
15	0.2	0.2	0.2	0.2	0.2	0.2	0.2	
16	0.3	0.3	0.3	0.3	0.3	0.3	0.3	
17	0.4	0.4	0.4	0.4	0.4	0.4	0.4	
18	0.6	0.6	0.6	0.6	0.6	0.5	0.5	
19	0.8	0.8	0.8	0.8	0.7	0.7	0.7	
20	1.1	1.0	1.0	1.0	1.0	0.9	0.9	
21	1.4	1.3	1.3	1.3	1.2	1.2	1.2	
22	2.2	1.8	1.7	1.6	1.6	1.5	1.4	
23	3.0	2.6	2.4	2.2	2.0	1.9	1.8	
24	3.9	3.4	3.2	3.0	2.6	2.4	2.2	
25	4.8	4.2	4.0	3.8	3.4	3.0	2.8	
26	5.7	5.1	4.8	4.6	4.2	3.8	3.4	
27	6.6	6.0	5.7	5.5	5.0	4.5	4.2	
28	7.5	6.9	6.6	6.3	5.8	5.3	4.9	

Note:

The values in the table refer to doors with an edge radius of 1 mm.

On doors with other radii, the minimum reveal changes as follows:

Radius 0 mm:
Value in table + 0.4 mm

Radius 3 mm:
Value in table - 0.6 mm

Note

The drawings below show the hinges including mounting plate distances on a scale of 1:1. Allowing for cup distance C (3 - 8 mm) as well as the minimum reveal, the required mounting plate distance and hole line can be determined by drawing in the door and side panel.

You can visit our Hettich channel on YouTube for further information on how to configure cabinets.

Inset (B -25 mm) - scale 1:1

Distance D = 0.71 x (C + B + F)
 = 0.71 x (cup distance C - 25 mm + reveal F)

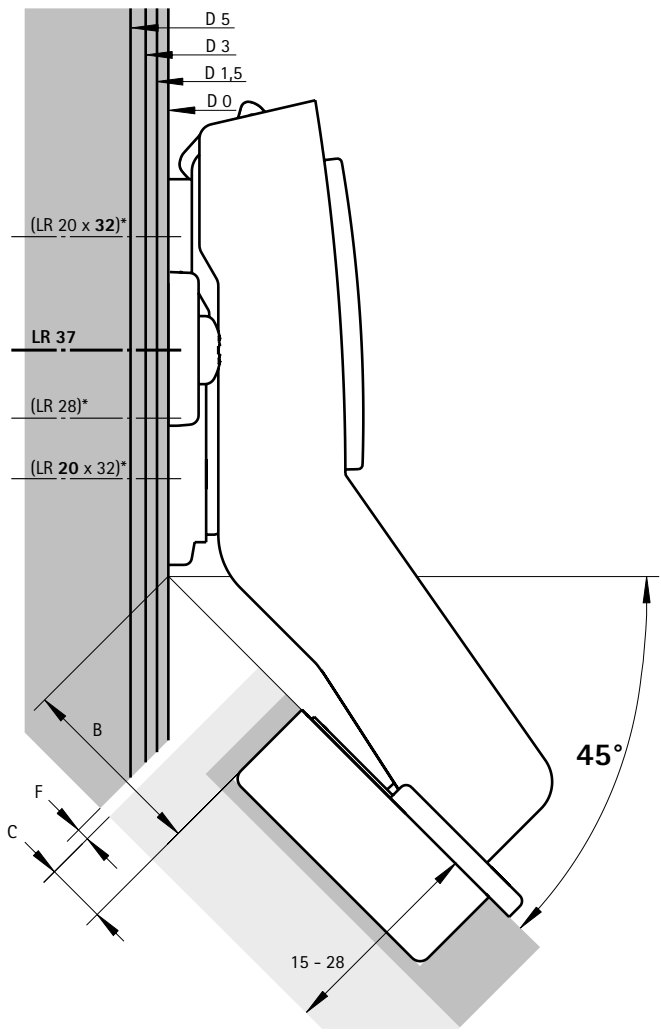

▶ Advice

*not available on all markets
 For mounting plates and accessories, see page 42 - 50
 For example applications and technical information, see pages 52 - 59

Fast assembly concealed hinge with integrated Silent System

- ▶ Sensys 8639i W90
- ▶ For 90° face angles, 95° opening angle



- ▶ Concealed clip on hinge with integrated Silent System
- ▶ Quality classification in accordance with EN 15570, Level 3
- ▶ For corner cabinets
- ▶ For door thickness of 15 - 28 mm
- ▶ Cup diameter 35 mm
- ▶ Cup depth 12.8 mm
- ▶ Integrated adjustment of door offset + 1 mm / - 2 mm
- ▶ Integrated reveal adjustment + 3 mm / - 2 mm
- ▶ Height adjustment at mounting plate
- ▶ Hinge arm material: nickel plated die cast zinc
- ▶ Hinge cup material: nickel plated steel

Sensys 8639i W90, 95° opening angle

Inset	
Basis B 4 mm	PU

Cup installation	Drilling pattern	Fixing hole ø x T mm	Part number	Quantity
Screw on version TH 52		-	9 085 170	200 ea.
Press in version TH 53		ø 10 x 11	9 085 175	200 ea.
Flash fast assembly TH 54		ø 10 x 11	9 085 180	200 ea.
Fix fast assembly THS 55		ø 10 x 6	9 085 340	200 ea.
With prem. Euro screws TH 56		ø 5 x 11	9 085 185	200 ea.
Screw on version TB 52		-	9 085 195	200 ea.
Press in version TB 53		ø 8 x 11	9 085 200	200 ea.
Flash fast assembly TB 54		ø 8 x 11	9 085 205	200 ea.
Fix fast assembly TB 55		ø 8 x 6	9 085 345	200 ea.
With prem. Euro screws TH 56		ø 5 x 11	9 085 210	200 ea.

Fast assembly concealed hinge without integrated Silent System

- ▶ Sensys 8639 W90
- ▶ For 90° face angles, 95° opening angle



- ▶ Concealed clip on hinge without integrated Silent System
- ▶ Quality classification in accordance with EN 15570, Level 3
- ▶ For corner cabinets
- ▶ For door thickness of 15 - 28 mm
- ▶ Cup diameter 35 mm
- ▶ Cup depth 12.8 mm
- ▶ Integrated adjustment of door offset + 1 mm / - 2 mm
- ▶ Integrated reveal adjustment + 3 mm / - 2 mm
- ▶ Height adjustment at mounting plate
- ▶ Hinge arm material: nickel plated die cast zinc
- ▶ Hinge cup material: nickel plated steel

Sensys 8639 W90, 95° opening angle

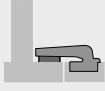
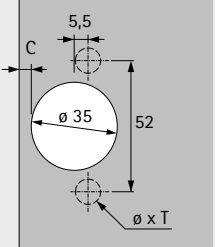
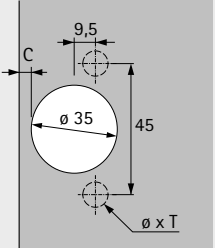
Cup installation	Drilling pattern	Fixing hole ø x T mm	Inset  Basis B 4 mm	PU
Screw on version TH 52		-	9 085 220	200 ea.
Press in version TH 53		ø 10 x 11	9 085 225	200 ea.
Fix fast assembly THS 55		ø 10 x 6	9 085 385	200 ea.
Fix fast assembly TB 55		ø 8 x 6	9 085 390	200 ea.

Fast assembly concealed hinge without automatic closing function

- ▶ Sensys 8669 W90
- ▶ For 90° face angles, 95° opening angle



- ▶ Clip on hinge without automatic closing function
- ▶ For example, for Push to open applications
- ▶ Quality classification in accordance with EN 15570, Level 3
- ▶ For corner cabinets
- ▶ For door thickness of 15 - 28 mm
- ▶ Cup diameter 35 mm
- ▶ Cup depth 12.8 mm
- ▶ Integrated adjustment of door offset + 1 mm / - 2 mm
- ▶ Integrated reveal adjustment + 3 mm / - 2 mm
- ▶ Height adjustment at mounting plate
- ▶ Hinge arm material: nickel plated die cast zinc
- ▶ Hinge cup material: nickel plated steel

Sensys 8669 W90, 95° opening angle

Inset

Cup installation	Drilling pattern	Fixing hole ø x T mm	Basis B 4 mm	PU
Screw on version TH 52		-	9 085 270	200 ea.
Press in version TH 53		ø 10 x 11	9 085 275	200 ea.
Fix fast assembly THS 55		ø 10 x 6	9 085 430	200 ea.
Fix fast assembly TB 55		ø 8 x 6	9 085 435	200 ea.

Fast assembly concealed hinge

- ▶ Sensys 8639i W90 / Sensys 8639 W90 / Sensys 8669 W90
- ▶ For 90° face angles, 95° opening angle

Minimum reveal per door

Door thickness mm	Cup distance C mm					
	3.0	4.0	4.5	5.0	6.0	7.0
15	0.2	0.2	0.2	0.2	0.2	0.2
16	0.3	0.3	0.3	0.3	0.3	0.3
17	0.4	0.4	0.4	0.4	0.4	0.4
18	0.6	0.6	0.6	0.6	0.6	0.5
19	0.8	0.8	0.8	0.8	0.7	0.7
20	1.1	1.0	1.0	1.0	1.0	0.9
21	1.4	1.3	1.3	1.3	1.2	1.2
22	2.2	1.8	1.7	1.6	1.6	1.5
23	3.0	2.6	2.4	2.2	2.0	1.9
24	3.9	3.4	3.2	3.0	2.6	2.4
25	4.8	4.2	4.0	3.8	3.4	3.0
26	5.7	5.1	4.8	4.6	4.2	3.8
27	6.6	6.0	5.7	5.5	5.0	4.5
28	7.5	6.9	6.6	6.3	5.8	5.3

Note:

The values in the table refer to doors with an edge radius of 1 mm.

On doors with other radii, the minimum reveal changes as follows:

Radius 0 mm:

Value in table + 0.4 mm

Radius 3 mm:

Value in table - 0.6 mm

Note

Calculation of required mounting plate distance D and hole-line distance X to be observed: Depending on the required door offset, cup distance C (3 - 7 mm) and reveal F, the dimensions can be seen in the drawing or table below. The values stated for the hole line distance X apply when using a cross mounting plate for hole line 37.

Hole line distance X must be adjusted when using other mounting plates.

- LR 28: X - 9 mm

- LR 20 x 32: X - 17 mm / X + 15 mm

A door offset of 1 mm is recommended. Door offset can subsequently be corrected with the adjusting screw.

Determining hole line distance X mm when using mounting plate with hole line 37

Reveal mm	Cup distance C mm							
	3.0	3.5	4.0	4.5	5.0	5.5	6.0	7.0
0.5	35.0	34.5	34.0	33.5	33.0	32.5	32.0	31.0
1.5	34.0	33.5	33.0	32.5	32.0	31.5	31.0	30.0
2.5	33.0	32.5	32.0	31.5	31.0	30.5	30.0	29.0
3.5	32.0	31.5	31.0	30.5	30.0	29.5	29.0	28.0
4.5	31.0	30.5	30.0	29.5	29.0	28.5	28.0	27.0
5.5	30.0	29.5	29.0	28.5	28.0	27.5	27.0	26.0
6.5	29.0	28.5	28.0	27.5	27.0	26.5	26.0	25.0
7.5	28.0	27.5	27.0	26.5	26.0	25.5	25.0	24.0

Hole line distance X = 38.5 - C - F

Inset (B 4 mm) - scale 1:1

Distance D = 4 mm - door offset
(recommended door offset is 1 mm)

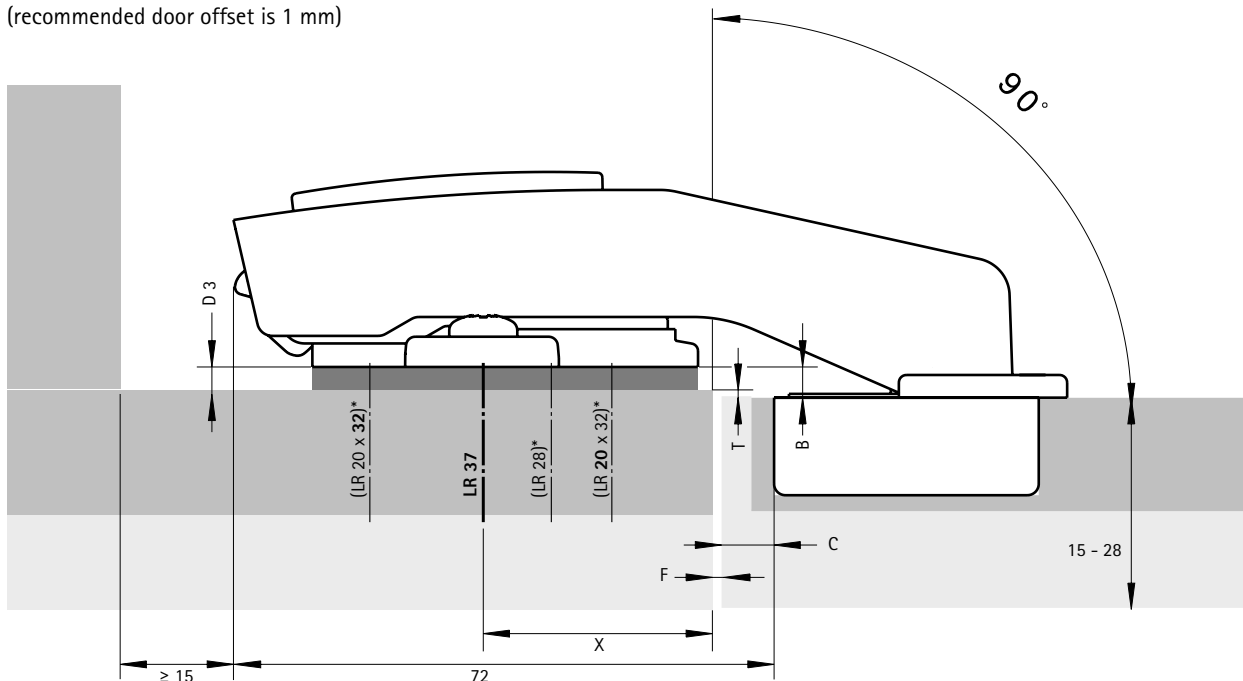

Advice

*not available on all markets

For mounting plates, see pages 40 - 47

For accessories, see pages 48 - 50

For technical information, see pages 52 - 59

Fast assembly concealed hinge with integrated Silent System

- ▶ Sensys 8638i for aluminium framed doors
- ▶ 95° opening angle



- ▶ Concealed clip on hinge with integrated Silent System
- ▶ Quality classification in accordance with EN 15570, Level 3
- ▶ For 19 mm wide aluminium framed profiles
- ▶ Integrated overlay adjustment + 2 mm / - 2 mm
- ▶ Integrated depth adjustment + 3 mm / - 2 mm
- ▶ Height adjustment at mounting plate
- ▶ Hinge arm material: nickel plated steel
- ▶ Hinge cup material: nickel plated die cast zinc
- ▶ Including 2 fixing screws

Sensys 8638i, 95° opening angle

	Full overlay	Half overlay	Inset	
Cup installation	Basis B 12.5 mm	Basis B 3 mm	Basis B - 4 mm	PU
Screw on version TA 32	9 071 421	9 071 422	9 071 423	200 ea.



Fast assembly concealed hinge without integrated Silent System

- ▶ Sensys 8638 for aluminium framed doors
- ▶ 95° opening angle

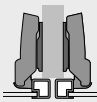

- ▶ Concealed clip on hinge without integrated Silent System
- ▶ Quality classification in accordance with EN 15570, Level 3
- ▶ For 19 mm wide aluminium framed profiles
- ▶ Integrated overlay adjustment + 2 mm / - 2 mm
- ▶ Integrated depth adjustment + 3 mm / - 2 mm
- ▶ Height adjustment at mounting plate
- ▶ Hinge arm material: nickel plated steel
- ▶ Hinge cup material: nickel plated die cast zinc
- ▶ Including 2 fixing screws

Sensys 8638, 95° opening angle

	Full overlay	Half overlay	Inset	
				
Cup installation	Basis B 12.5 mm	Basis B 3 mm	Basis B - 4 mm	PU
Screw on version TA 32	9 071 424	9 071 425	9 071 426	200 ea.



Fast assembly concealed hinge without automatic closing function

- ▶ Sensys 8668 for aluminium framed doors
- ▶ 95° opening angle

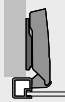
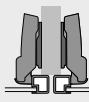

- ▶ Clip on hinge without automatic closing function
- ▶ For example, for Push to open applications
- ▶ Quality classification in accordance with EN 15570, Level 3
- ▶ For 19 mm wide aluminium framed profiles
- ▶ Integrated overlay adjustment + 2 mm / - 2 mm
- ▶ Integrated depth adjustment + 3 mm / - 2 mm
- ▶ Height adjustment at mounting plate
- ▶ Hinge arm material: nickel plated steel
- ▶ Hinge cup material: nickel plated die cast zinc
- ▶ Including 2 fixing screws

Sensys 8668, 95° opening angle

	Full overlay	Half overlay	Inset	
				
Cup installation	Basis B 12.5 mm	Basis B 3 mm	Basis B - 4 mm	PU
Screw on version TA 32	9 071 427	9 071 428	9 071 429	200 ea.

Fast assembly concealed hinge

- ▶ **Intermat 9930 for corner cabinet folding doors**
- ▶ **50° / 65° opening angle**



- ▶ Clip on concealed hinge
- ▶ Quality grades to EN 15570, Level 2
- ▶ Cup diameter 35 mm
- ▶ Cup depth 12.8 mm
- ▶ Diagonal adjustment + 9.5 mm / - 9.5 mm
- ▶ For integrated overlay adjustment, see sketch
- ▶ For integrated depth adjustment, see sketch
- ▶ Height adjustment at mounting plate
- ▶ Hinge arm material: nickel plated die cast zinc
- ▶ Hinge cup material: nickel plated steel

Intermat 9930, 50° / 65° opening angle

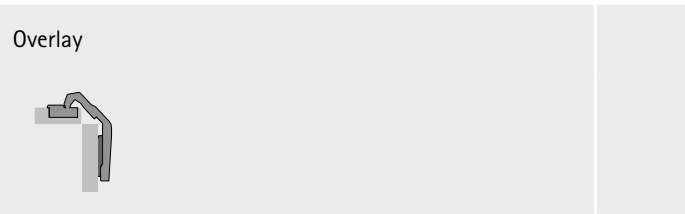

Cup installation	Drilling pattern	Fixing hole ø x T mm	Basis B 24 mm	PU
Screw on version TH 52		-	9 090 045	200 ea.
Press in version TH 53		ø 10 x 11	9 090 046	200 ea.
Flash fast assembly TH 54		ø 10 x 11	9 090 047	200 ea.
Fix fast assembly THS 55		ø 10 x 6	9 090 053	100 ea.
With prem. Euro screws TH 56		ø 5 x 11	9 090 101	200 ea.
Screw on version TB 52		-	9 090 048	200 ea.
Press in version TB 53		ø 8 x 11	9 090 049	200 ea.
Flash fast assembly TB 54		ø 8 x 11	9 090 050	200 ea.
Fix fast assembly TB 55		ø 8 x 6	9 090 057	100 ea.
With prem. Euro screws TH 56		ø 5 x 11	9 090 102	200 ea.

Fast assembly concealed hinge

- ▶ **Intermat 9930 for corner cabinet folding doors**
- ▶ **50° / 65° opening angle**

Version A - Cup drill holes in one door

- ▶ All cup drill holes in one door
- ▶ Minimum reveal can be provided between door elements
- ▶ No cutaway necessary in cup holes
- ▶ Same door width for both elements
- ▶ Diagonal adjustment capability for easy adjustment to door thickness
- ▶ Same cup distance on both sides of side mounted door
- ▶ Hole line distance in the folding door panel: 37 mm
- ▶ For door thickness of 15 - 21 mm
- ▶ Cup distance C 3 - 6 mm

Version A - Calculation of door width

Door width = carcass width - reveal F - door thickness

Version A - Calculation of mounting plate distance

For cup distance C = 4.5 mm: distance D = 0 mm
 For cup distance C = 3.0 mm: distance D = 1.5 mm

Cup distances other than these can be evened out by depth and diagonal adjustment.

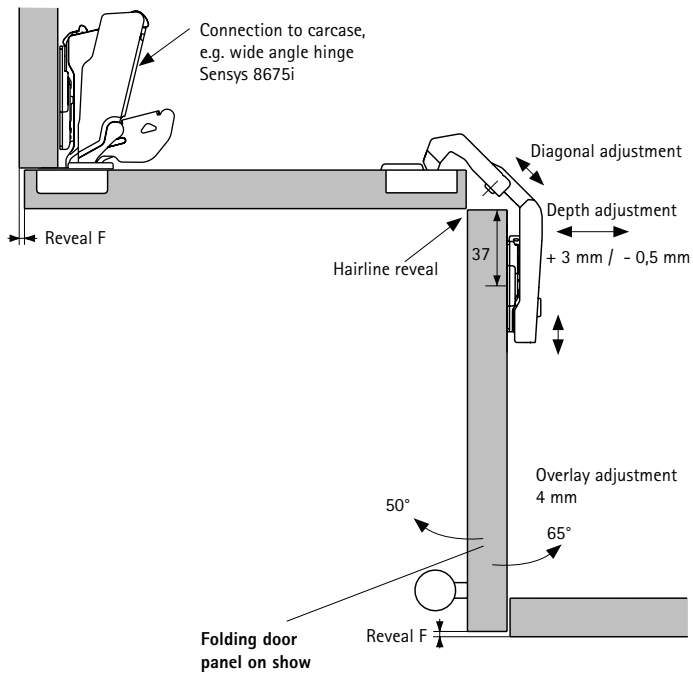

▶ Advice

For mounting plates, see pages 42 - 47
 For accessories, see pages 48 - 50
 For technical information, see pages 52 - 59

Version B - Cup drill holes in both doors

- ▶ Both door elements are the same
- ▶ No cutaway necessary in cup holes
- ▶ Diagonal adjustment capability for easy adjustment to door thickness
- ▶ Hole line distance in the side mounted door: 41 mm
- ▶ For door thickness of 15 - 21 mm
- ▶ Cup distance C 3 - 6 mm

Version B - Calculation of door width

Door width = carcass width - reveal F - door thickness - 5 mm

Version B - Calculation of mounting plate distance

For cup distance C = 4.5 mm: distance D = 0 mm
 For cup distance C = 3.0 mm: distance D = 1.5 mm

Cup distances other than these can be evened out by depth and diagonal adjustment.

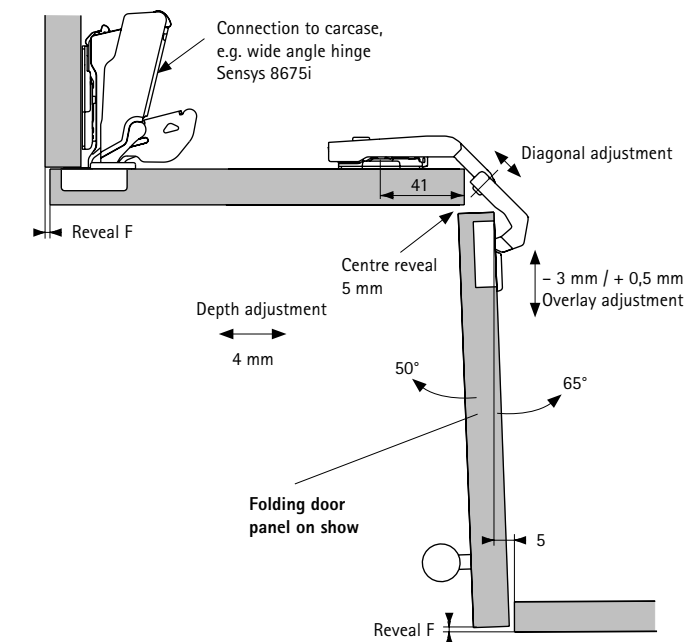

Fast assembly concealed hinge

- ▶ Adapter for glue mounting Sensys
- ▶ For Sensys



- ▶ Adapter for glue mounting Sensys
- ▶ Quality classification defined by the hinges used
- ▶ For use with
 - Sensys 8645i, B -4 mm, TH 52
 - Sensys 8631i, B -4 mm, TH 52
 - Sensys 8657i, B 3 mm, TH 52
 - the relevant product version without integrated Silent System, or without automatic closing function, can be used in the same way
- ▶ For glass doors
- ▶ For glass on a thickness of 3 - 7 mm
- ▶ For use with UV hardening adhesive
- ▶ Supplied without adhesive
- ▶ Material: nickel plated die cast zinc

Adapter for glue mounting Sensys

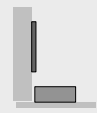
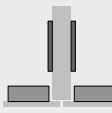
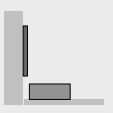
		Full overlay	Half overlay	Inset	
					
	Cup				PU
Sensys 8657i B 3 mm, 165° opening angle	TH 52	9 099 550	9 099 550		50 ea.
Sensys 8631i B -4 mm, 95° opening angle	TH 52			9 090 280	200 ea.
Sensys 8645i B -4 mm, 110° opening angle	TH 52			9 071 207	200 ea.
Adapter (small pack, including fixing screws)	TH	9 081 923	9 081 923	9 081 923	2 ea.
Adapter (large pack, without fixing screws)	TH	9 076 738	9 076 738	9 076 738	50 ea.
Fixing screws		9 076 418	9 076 418	9 076 418	100 ea.

Fast assembly concealed hinge

- ▶ Adapter for glue mounting Sensys
- ▶ For Sensys

Gluing dimension K

Gluing dimension K	A	F	D1.5	D3	D5	D8
Inset		2	2.5	4		
Full overlay /	0					4
Half overlay	1				2	5
	2				3	6
	3				4	7
	4				5	8
	5				6	9
	6				7	10
	7				8	11
	8				9*	12*
	9				10*	13*
	10				11*	14*
	11				12*	15*
	12				13*	16*
	13				14*	17*
	14				15*	18*
	15				16*	19*
	16				17*	20*
	17				18*	21*
	18				19*	22*
	19				20*	23*

Abbreviations

- K = gluing dimension
- A = overlay
- F = reveal
- D = distance
- T = door thickness
- X = hole line

Minimum reveal per door

When calculating door mounting, allowance must be made for a minimum reveal of 2mm per door.
 The edges of the glass door must be bevelled:
 - at least 1 mm
 - max. gluing dimension K - 1 mm

- Sensys 8645i or 8631i
- Sensys 8631i
- Sensys 8657i
- * When using the opening angle limiter at 120°

Full overlay

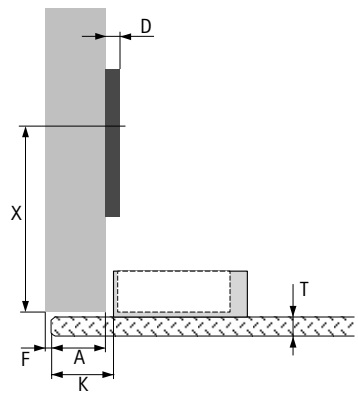

Half overlay

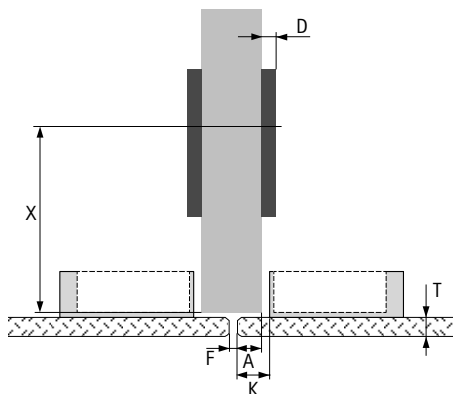

Inset

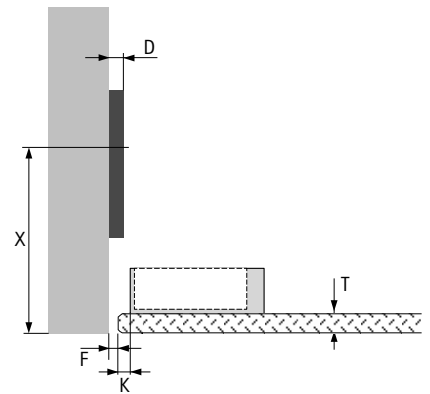

Hole-line distance X

Door mounting option	Mounting plate		
	LR 37	(LR 28)*	(LR 20 x 32)**
Full overlay	50 mm	41 mm	33 mm**
Half overlay	50 mm	41 mm	33 mm**
Inset	T + 52 mm	T + 43 mm	T + 35 mm**

* not available on all markets
 ** Distance for front hole position in 32 mm hole line pattern

Fitting information

The adapter must be glued to a glass door by a specialised fabricator who must also select an adhesive and gluing method suitable for the door's specific properties. Details on the exact size and finish of the surface for gluing the adapter to are shown in the installation advice provided with the product. Hettich accepts no responsibility for gluing the adapter on incorrectly.

For safety reasons, the hinge cup must only be screwed on using the fixing screws offered. Two screws are required per hinge.

▶ Advice

- For mounting plates, see pages 42 - 47
- For accessories, see pages 48 - 50
- For technical information, see pages 52 - 59
- For example applications, see page 52 - 53

- ▶ System 8099 mounting plates with oblong hole height adjustment capability
- ▶ For Sensys and Intermat

Screw on cross mounting plate

- ▶ For \varnothing 4.5 x 16 mm countersunk wood screws
- ▶ Quality classification in accordance with EN 15570, Level 3
- ▶ Hole spacing 32 mm
- ▶ Oblong hole height adjustment \pm 3 mm
- ▶ Steel, nickel plated

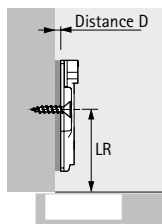

Distance D mm	Hole line distance LR mm 37	PU
0.0	9 071 575	200 ea.
1.5	9 071 576	200 ea.
3.0	9 071 577	200 ea.
5.0	9 071 578	200 ea.



Press in cross mounting plate

- ▶ For \varnothing 10 x 12 mm holes
- ▶ Quality classification in accordance with EN 15570, Level 3
- ▶ Hole spacing 32 mm
- ▶ Oblong hole height adjustment \pm 2 mm
- ▶ Steel, nickel plated

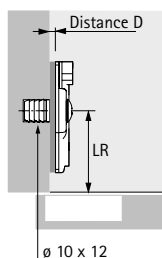

Distance D mm	Hole line distance LR mm 37	PU
0.0	9 071 615	200 ea.
1.5	9 071 616	200 ea.
3.0	9 071 617	200 ea.
5.0	9 071 618	200 ea.



Cross mounting plate with expanding sockets and special screws

- ▶ For \varnothing 10 x 12 mm holes
- ▶ Quality classification in accordance with EN 15570, Level 3
- ▶ Hole spacing 32 mm
- ▶ Oblong hole height adjustment \pm 2 mm
- ▶ Steel, nickel plated

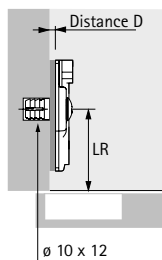

Distance D mm	Hole line distance LR mm 37	PU
0.0	9 071 605	200 ea.
1.5	9 071 606	200 ea.
3.0	9 071 607	200 ea.
5.0	9 071 608	200 ea.



Cross mounting plate with expanding sockets and special screws

- ▶ For \varnothing 5 x 12 mm holes
- ▶ Quality classification in accordance with EN 15570, Level 3
- ▶ Hole spacing 32 mm
- ▶ Oblong hole height adjustment \pm 2.5 mm
- ▶ Steel, nickel plated

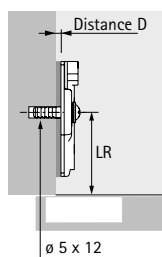

Distance D mm	Hole line distance LR mm 37	PU
0	9 071 595	200 ea.
1.5	9 071 596	200 ea.
3.0	9 071 597	200 ea.
5.0	9 071 598	200 ea.



Fast assembly concealed hinge

- ▶ System 8099 mounting plates with oblong hole height adjustment capability
- ▶ For Sensys and Intermat

Cross mounting plate with premounted Euro screws

- ▶ For $\varnothing 5 \times 12$ mm holes
- ▶ Quality classification in accordance with EN 15570, Level 3
- ▶ Hole spacing 32 mm
- ▶ Oblong hole height adjustment ± 3 mm
- ▶ Steel, nickel plated

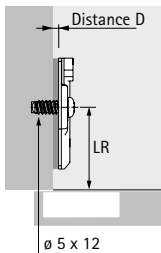

Distance D mm	Hole line distance LR mm 37	PU
0.0	9 071 625	200 ea.
1.5	9 071 626	200 ea.
3.0	9 071 627	200 ea.
5.0	9 071 628	200 ea.



Patented "Hettich Direkt" cross mounting plate with pilot pin and special screws

- ▶ For $\varnothing 5 \times 7.5$ mm holes
- ▶ Quality classification in accordance with EN 15570, Level 2
- ▶ Hole spacing 32 mm
- ▶ Half overlay door, from 15 mm side panel thickness
- ▶ Oblong hole height adjustment ± 2.5 mm
- ▶ Steel, nickel plated

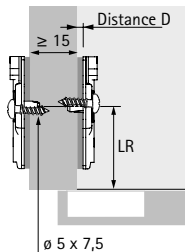

Distance D mm	Hole line distance LR mm 37	PU
0.0	9 071 585	200 ea.
1.5	9 071 586	200 ea.
3.0	9 071 587	200 ea.
5.0	9 071 588	200 ea.



Screw on linear mounting plate

- ▶ For $\varnothing 3.5 \times 16$ mm countersunk wood screws
- ▶ Quality classification in accordance with EN 15570, Level 3
- ▶ Oblong hole height adjustment ± 1.6 mm
- ▶ Die cast zinc, nickel plated

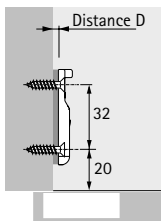

Distance D mm	Hole line distance LR mm 20 x 32	PU
0.5	9 084 993	200 ea.
3.0	9 084 994	200 ea.



Press in linear mounting plate

- ▶ For $\varnothing 10 \times 12$ mm hole
- ▶ Quality classification in accordance with EN 15570, Level 3
- ▶ Oblong hole height adjustment ± 1.6 mm
- ▶ Die cast zinc, nickel plated

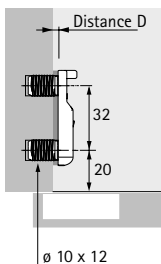

Distance D mm	Hole line distance LR mm 20 x 32	PU
0.5	9 084 991	200 ea.
3.0	9 084 992	200 ea.



Fast assembly concealed hinge

- ▶ System 8000 mounting plates with oblong hole height adjustment capability
- ▶ For Sensys

System 8000 screw on face frame mounting plate

- ▶ For $\varnothing 4 \times 20$ mm countersunk wood screws
- ▶ Quality classification in accordance with EN 15570, Level 3
- ▶ Hole spacing 40 mm
- ▶ Oblong hole height adjustment ± 2 mm
- ▶ Can only be used with Sensys hinges
- ▶ Die cast zinc, nickel plated

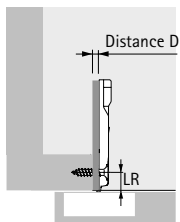

Distance D mm	Hole line distance LR mm	PU
	9.5	
0.0	9 084 930	200 ea.
1.5	9 085 598	200 ea.
4.5	9 084 931	200 ea.



Fast assembly concealed hinge

- ▶ System 8099 mounting plates with cam height adjustment capability
- ▶ For Sensys and Intermat

Press in cross mounting plate

- ▶ For $\varnothing 10 \times 12$ mm holes
- ▶ Quality classification in accordance with EN 15570, Level 3
- ▶ Hole spacing 32 mm
- ▶ Cam height adjustment ± 2 mm
- ▶ Steel, nickel plated

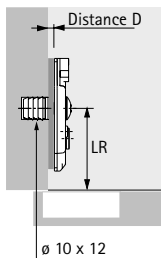

Distance D mm	Hole line distance LR mm	PU
	37	
0.0	9 071 680	200 ea.
1.5	9 071 681	200 ea.
3.0	9 071 682	200 ea.
5.0	9 071 683	200 ea.

Cross mounting plate with expanding sockets and special screws

- ▶ For $\varnothing 10 \times 12$ mm holes
- ▶ Quality classification in accordance with EN 15570, Level 3
- ▶ Hole spacing 32 mm
- ▶ Cam height adjustment ± 2 mm
- ▶ Steel, nickel plated

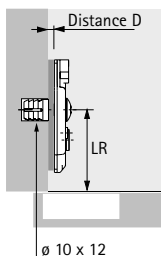

Distance D mm	Hole line distance LR mm	PU
	37	
0.0	9 071 660	200 ea.
1.5	9 071 661	200 ea.
3.0	9 071 662	200 ea.
5.0	9 071 663	200 ea.

Cross mounting plate with expanding sockets and special screws

- ▶ For $\varnothing 5 \times 12$ mm holes
- ▶ Quality classification in accordance with EN 15570, Level 3
- ▶ Hole spacing 32 mm
- ▶ Cam height adjustment ± 2 mm
- ▶ Steel, nickel plated

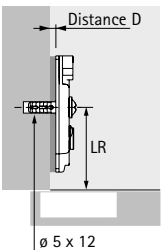

Distance D mm	Hole line distance LR mm	PU
	37	
0.0	9 071 655	200 ea.
1.5	9 071 656	200 ea.
3.0	9 071 657	200 ea.
5.0	9 071 658	200 ea.

Cross mounting plate with premounted chipboard screws

- ▶ For holes with max. $\varnothing 2.5$ mm
- ▶ Quality classification in accordance with EN 15570, Level 3
- ▶ Hole spacing 32 mm
- ▶ Cam height adjustment ± 2 mm
- ▶ Steel, nickel plated

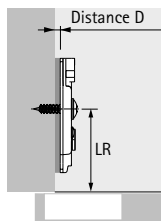

Distance D mm	Hole line distance LR mm	PU
	37	
0.0	9 071 670	200 ea.
1.5	9 071 671	200 ea.
3.0	9 071 672	200 ea.
5.0	9 071 673	200 ea.

- ▶ System 8099 mounting plates with cam height adjustment capability
- ▶ For Sensys and Intermat

Cross mounting plate with premounted Euro screws

- ▶ For $\varnothing 5 \times 12$ mm holes
- ▶ Quality classification in accordance with EN 15570, Level 3
- ▶ Hole spacing 32 mm
- ▶ Cam height adjustment ± 2 mm
- ▶ Steel, nickel plated

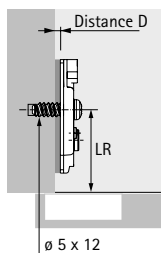

Distance D mm	Hole line distance LR mm	PU
	37	
0.0	9 071 665	200 ea.
1.5	9 071 666	200 ea.
3.0	9 071 667	200 ea.
5.0	9 071 668	200 ea.



Cross mounting plate with premounted Euro screws

- ▶ For $\varnothing 5 \times 8$ mm holes
- ▶ Quality classification in accordance with EN 15570, Level 3
- ▶ Hole spacing 32 mm
- ▶ Half overlay door, from 16 mm side panel thickness
- ▶ Cam height adjustment ± 2 mm
- ▶ Steel, nickel plated

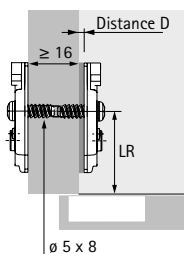

Distance D mm	Hole line distance LR mm	PU
	37	
0.0	9 071 645	200 ea.
1.5	9 071 646	200 ea.
3.0	9 071 647	200 ea.
5.0	9 071 648	200 ea.



Patented "Hettich Direkt" cross mounting plate with pilot pin and special screws

- ▶ For $\varnothing 5 \times 7.5$ mm holes
- ▶ Quality classification in accordance with EN 15570, Level 2
- ▶ Hole spacing 32 mm
- ▶ Half overlay door, from 15 mm side panel thickness
- ▶ Cam height adjustment ± 2 mm
- ▶ Steel, nickel plated

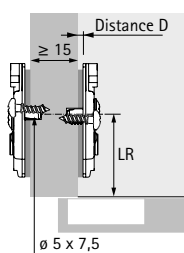

Distance D mm	Hole line distance LR mm	PU
	37	
0.0	9 071 650	200 ea.
1.5	9 071 651	200 ea.
3.0	9 071 652	200 ea.
5.0	9 071 653	200 ea.



Screw on linear mounting plate

- ▶ For $\varnothing 3.5 \times 16$ mm countersunk wood screws
- ▶ Quality classification in accordance with EN 15570, Level 3
- ▶ Cam height adjustment ± 2 mm
- ▶ Steel, nickel plated

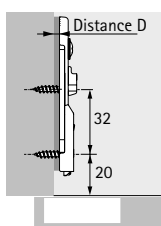

Distance D mm	Hole line distance LR mm	PU
	20 x 32	
1.5	9 071 687	200 ea.
3.0	9 071 688	200 ea.
5.0	9 071 689	200 ea.



Fast assembly concealed hinge

- ▶ System 8099 mounting plates with cam height adjustment capability
- ▶ For Sensys and Intermat

Press in linear mounting plate

- ▶ For $\varnothing 10 \times 12$ mm holes
- ▶ Quality classification in accordance with EN 15570, Level 3
- ▶ Cam height adjustment ± 2 mm
- ▶ Steel, nickel plated

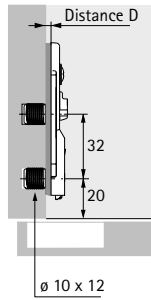

Distance D mm	Hole line distance LR mm 20 x 32	PU
1.5	9 071 697	200 ea.
3.0	9 071 698	200 ea.
5.0	9 071 699	200 ea.

Mounting plate solution for inframe applications

- ▶ For attachment with premounted Euro screws
- ▶ Hole distance: 32 mm
- ▶ Height adjustment: ± 2 mm
- ▶ For 1/2 overlay hinge application only
- ▶ Total height 34 mm

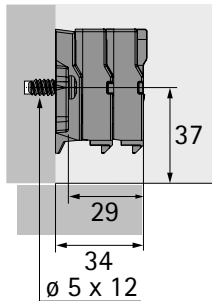

Distance D mm	Total height mm 34	PU
29	9 072 296	200 ea.

- ▶ Sensys
- ▶ Accessories

Parallel adapter for cross mounting plates

- ▶ For increasing the mounting plate distance by a maximum of 22 mm
- ▶ Including fixing screw
- ▶ A trial door mounting is recommended
- ▶ Die cast zinc, nickel plated

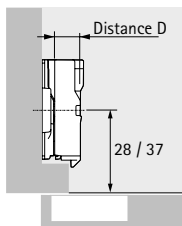

Distance D mm	Order no.	PU
8.0	9 072 231	200 ea.
12.0	9 072 232	200 ea.
22.0	9 072 233	200 ea.

Can only be used with Intermat System 9000 cross mounting plates with oblong hole height adjustment, see page Intermat catalogue (www.hettich.com / service / media library)

Angle adapter for cross mounting plates

- ▶ For producing angled mounting options
- ▶ 5° angle adapter can be stacked on the other angle adapters
- ▶ A trial door mounting is recommended
- ▶ Die cast zinc, nickel plated

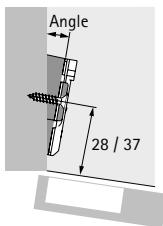

Angle °	Order no.	PU
5	9 072 214	200 ea.
10	9 072 215	200 ea.
15	9 072 216	200 ea.
20	9 072 217	200 ea.

Can only be used with screw on cross mounting plates, see page 42; screw length is defined by the specific configuration

Cover cap for Sensys hinge arm



- ▶ Can be used with Sensys hinges apart from 8657i / 8657 / 8687
- ▶ Cover caps with customised imprint available on request
- ▶ Steel, nickel plated

Type	Order no.	PU
Embossed with Hettich logo	9 082 774	200 ea.
Neutral	9 082 612	200 ea.

Cover cap for hinge cup

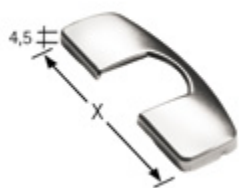

- ▶ Can be used for Sensys and Intermat 9930 with cup in Sensys design
- ▶ Steel, nickel plated

Type	Dim. X mm	Order no.	PU
for TH52, TH53, TH54, TH56, TS52, TS53, TS54, TS56	68.2	9 082 614	200 ea.
for TB52, TB53, TB54, TB56	61.4	9 084 924	200 ea.

Fixing screw



- ▶ Countersunk head
- ▶ Pozidrive screw
- ▶ Steel, nickel-plated

Version	Dimensions mm	Order no.	PU
For screw on cup	ø 3.5 x 16	0 071 925	200 ea.
For aluminium frame hinge	ø 3.5 x 9.5	0 041 296	200 ea.

- ▶ Sensys
- ▶ Accessories

Adapter for reducing drilling depth

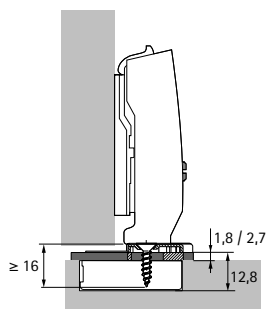

- ▶ To reduce the required depth of the cup drilling in thin or highly softened doors
- ▶ Can be used with screw on hinge cup
- ▶ The gap between carcass and door increases by the thickness of the adapter
- ▶ Mounting with $\varnothing 4 \times 16$ mm countersunk wood screws
- ▶ Transparent plastic

Type	Thickness mm	Order no.	PU
For cup TH, TS	1.8	9 072 980	200 ea.
For cup TH, TS	2.7	9 072 981	200 ea.
For cup TB	1.8	9 072 982	200 ea.
For cup TB	2.7	9 072 983	200 ea.

Opening angle limiter



- ▶ For reducing the opening angle of doors to avoid collisions with adjoining elements
- ▶ This avoids damaging the front
- ▶ For assembly advice, see pages 56 - 57

Type	Opening angle limiter	Order no.	PU
1 For Sensys 8645i / 8645 / 8675	from 110° to 85°	9 071 468	200 ea.
2 For Sensys 8631i / 8631 / 8661	from 95° to 85°	9 100 039	200 ea.
3 For Sensys 8657i / 8657 / 8687	from 165° to 105° / 120°	9 090 756	50 ea.
4 For Sensys 8639i W / 8639 W / 8669 W	from 95° to 85°	9 071 469	200 ea.
5 For Sensys 8638i / 8638 / 8668	from 95° to 85°	9 071 470	200 ea.

Aid for installing opening angle limiter



- Can be used with the following opening angle limiters
- Order no. 9 071 468 for Sensys 8645i / 8645 / 8675
 - Order no. 9 071 469 for Sensys 8639i W / 8639 W / 8669 W

Order no.	PU
9 081 657	100 ea.

Fast assembly concealed hinge

- ▶ Sensys
- ▶ Accessories

Cover cap ø 35 mm

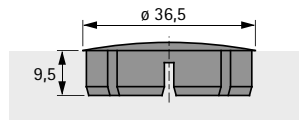

- ▶ For hole dia. 35 x 9.5 mm
- ▶ Plastic

Colour	Order no.	PU
White	0 025 204	100 ea.
Brown	0 025 205	100 ea.

Press-in buffer

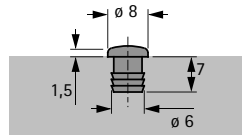

- ▶ For hole ø 6 x 7 mm
- ▶ Plastic

Colour	Order no.	PU
Brown	0 021 154	1000 ea.
White	0 025 048	1000 ea.
Beige	0 047 353	1000 ea.

Press-in buffer

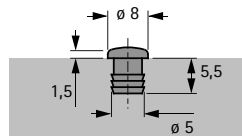

- ▶ For hole ø 5 x 5.5 mm
- ▶ Transparent plastic

Order no.	PU
9 079 298	1000 ea.

Stick-on buffer

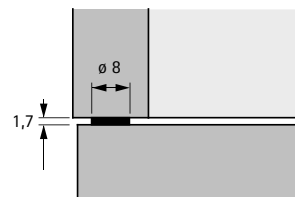

- ▶ Self-adhesive
- ▶ Transparent plastic

Order no.	PU
0 072 120	50 ea.
0 046 695	1000 ea.

Technical information

- ▶ Sensys
- ▶ Example applications

Example applications for Sensys 8639i W30

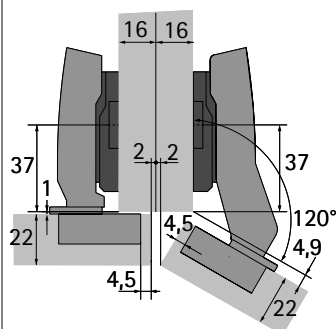

Sensys 8639i W30 B2
for overlay front
Mounting plate* distance = 3 mm

Sensys 8645i B12.5
for overlay front
Mounting plate* distance = 3 mm

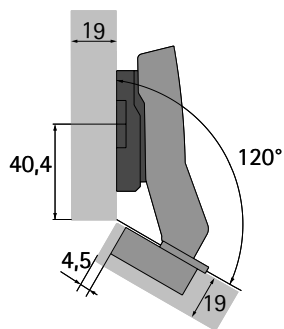

Sensys 8639i W30 B2
for overlay front
Mounting plate* distance = 5 mm

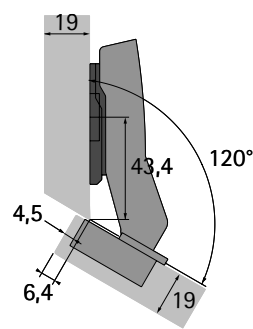

Sensys 8639i W30 B2
for overlay front
Mounting plate* distance = 0 mm

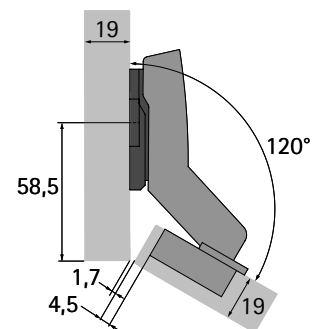

Sensys 8639i W30 B-16
for inset front
Mounting plate* distance = 1.5 mm

* The position shown in the drawing for screw mounting the mounting plate refers to the use of a mounting plate with hole line distance LR = 37 mm

Example applications for Sensys 8639i W45

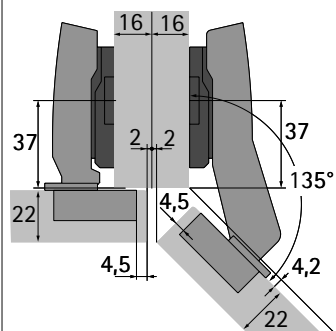

Sensys 8639i W45 B-2
for overlay front
Mounting plate* distance = 3 mm

Sensys 8645i B12.5
for overlay front
Mounting plate* distance = 3 mm

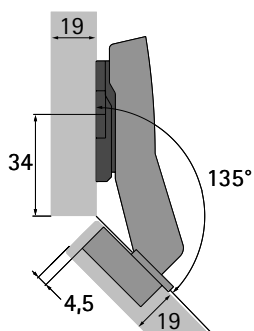

Sensys 8639i W45 B-2
for overlay front
Mounting plate* distance = 1.5 mm

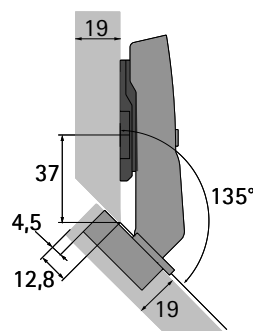

Sensys 8639i W45 B9
for overlay front
Mounting plate* distance = 0 mm

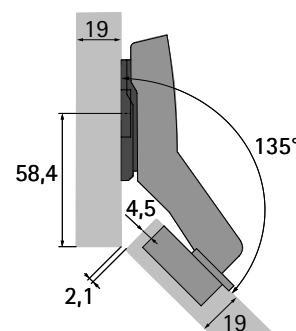

Sensys 8639i W45 B-25
for inset front
Mounting plate* distance = 0 mm

* The position shown in the drawing for screw mounting the mounting plate refers to the use of a mounting plate with hole line distance LR = 37 mm

Technical information

- ▶ Sensys
- ▶ Example applications

Example applications for Sensys 8631i

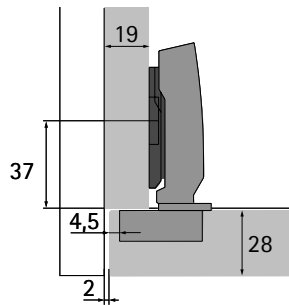

Sensys 8631i B12.5
Thick door
 for full overlay front
 Mounting plate* distance = 0 mm

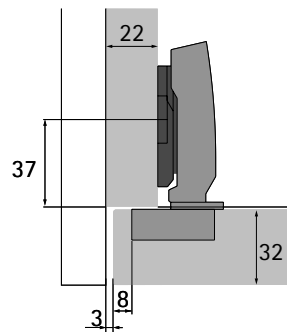

Sensys 8631i B12.5
Thick door
 for full overlay front
 Mounting plate* distance = 1.5 mm

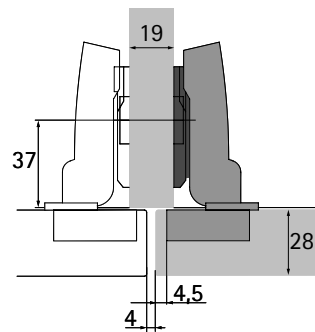

Sensys 8631i B3
Thick door
 for half overlay front
 Mounting plate* distance = 0 mm

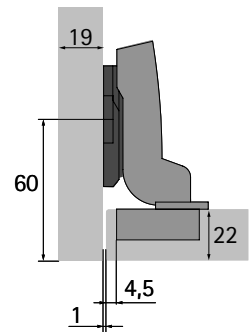

Sensys 8631i B-4
Thick door
 for inset front
 Mounting plate* distance = 1.5 mm

* The position shown in the drawing for screw mounting the mounting plate refers to the use of a mounting plate with hole line distance LR = 37 mm

Example applications for adapter for glue mounting Sensys

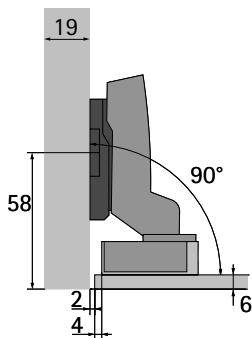

Sensys 8645i B-4 / 8631i B-4
with adapter for glue mounting Sensys
 for inset front
 Mounting plate* distance = 3 mm

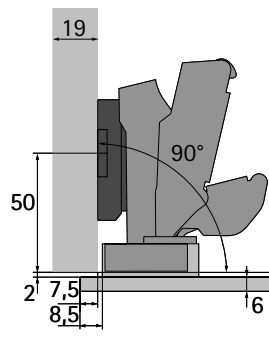

Sensys 8657i B3
with adapter for glue mounting Sensys
 for half overlay front
 Mounting plate* distance = 5 mm
 120° opening angle limiter

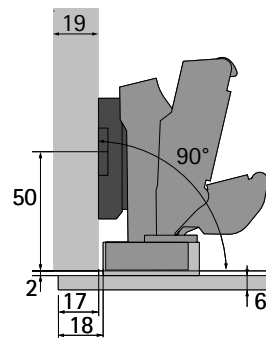

Sensys 8657i B3
with adapter for glue mounting Sensys
 for full overlay front
 Mounting plate* distance = 5 mm
 120° opening angle limiter

* The position shown in the drawing for screw mounting the mounting plate refers to the use of a mounting plate with hole line distance LR = 37 mm

Technical information

- ▶ Sensys
- ▶ Fitting information

Full overlay door

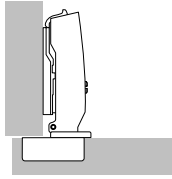

The door is in front of the carcass side and only a small gap remains at the side within which the door can open reliably. Alternatively, the door can also be overlaid fully, in which case sufficient space must be allowed at the side for the required minimum reveal. Straight hinges are used.

Half overlay door

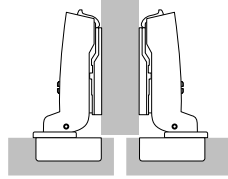

This is where two doors are positioned in front of a cabinet center panel. With the required overall reveal between them (at least 2 x minimum reveal). In other words, each door has a smaller overlay and cranked hinges are therefore used.

Inset door

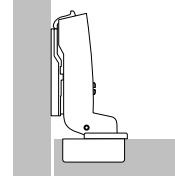

The door is positioned inside the carcass, i.e. next to the carcass side. Here too, a gap is needed so that the door can open reliably. Highly cranked hinges are used here. For an inset door, the mounting plate must be set back by the thickness of the door + 1 mm as well as by any any chosen door offset.

Minimum reveal

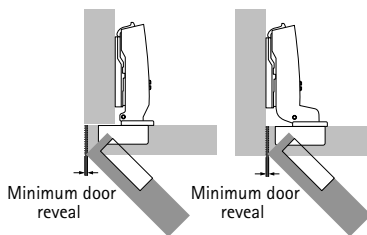

For overlay and inset door

The minimum reveal (also known as the door clearance or minimum clearance) is the space required at the side for opening the door. The size of the minimum reveal depends on the cup distance C, the door thickness and the type of hinge selected. Radii on the door edges reduce the door clearance. The minimum reveal is shown in the table for the respective hinge types.

Minimum reveal

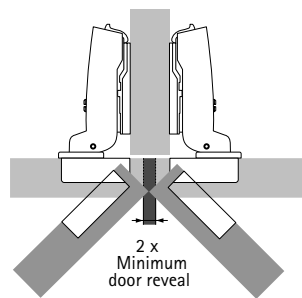

For half-overlay doors

The total reveal selected between the doors must be at least twice the door clearance. Both doors can then be opened at the same time.

Cup distance C

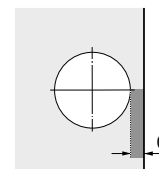

Cup distance C is the distance between door edge and the edge of the cup drilling. The greater the distance selected for cup distance C, the smaller door clearance will be, i.e. the minimum reveal required.

Overlay / Basis

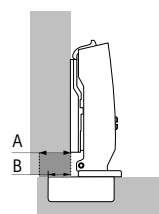

A = Overlay
B = Basis

Overlay refers to the projection of the door in front of the carcass side. Basis refers to the projection of the cup in front of the carcass side for a mounting plate distance of 0 mm.

Number of hinges per door

Door width, height and weight as well as the material quality of the door are decisive factors determining the number of hinges required.

The factors encountered in practice differ widely from case to case. For this reason, the number of hinges specified in the diagram must be understood as a guide only. If in doubt, it is recommended to carry out a trial door mounting and adjust the number of hinges as necessary. For reasons of stability, space X between the hinges must always be made as large as possible. Distance X must be at least 280 mm.

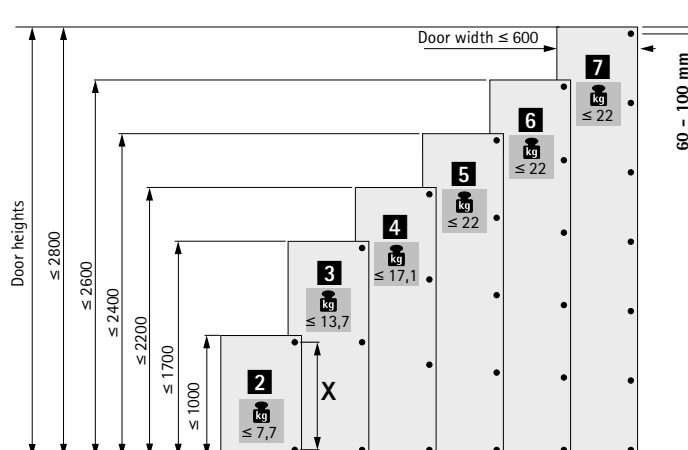

Technical information

- ▶ Sensys
- ▶ Fitting information

General calculation of distances

Mounting plates are available in various distances. The effective height of the mounting plate is defined by distance D. Distance D is embossed on the top of each mounting plate. A larger distance D reduces overlay for full and half overlay applications. On inset doors, a larger distance D increases the door reveal. Before determining the required distance, check whether the desired

reveal is equal to or greater than the required minimum reveal. If the desired reveal is less than the required minimum reveal, the required minimum reveal can be reduced by increasing cup distance C or by producing radii on the door edges.

Calculating distances

For overlay and half overlay doors

The required distance D can be determined after checking the minimum reveal. Ideally, door reveal and value C should be selected to produce distance D that is available as mounting plate.

Example: Determine distance from table

Overlay = 14 mm and cup distance C = 4.5 mm yield a distance of 3.0 mm.

Example: Distance determined according to calculation formula

Hinge for overlay door, basis B = 12.5 mm

Distance D = Cup distance C + Basis B - Overlay A

Distance D = 4.5 mm + 12.5 mm - 14 mm = 3.0 mm

Intermediate distances, which are not available as mounting-plate distance, are achieved by adjusting the hinge overlay.

Overlay mm	Cup distance C mm					
	3,0	4,0	4,5	5,0	6,0	7,0
	Distance D mm					
10	5,5	6,5	7,0	7,5	8,5	9,5
11	4,5	5,5	6,0	6,5	7,5	8,5
12	3,5	4,5	5,0	5,5	6,5	7,5
13	2,5	3,5	4,0	4,5	5,5	6,5
14	1,5	2,5	3,0	3,5	4,5	5,5
15	0,5	1,5	2,0	2,5	3,5	4,5
16		0,5	1,0	1,5	2,5	3,5
17			0,0	0,5	1,5	2,5
18					0,5	1,5
19						0,5

Calculating distances

For inset doors

When calculating the mounting-plate distance using the table for inset doors, allowance is automatically made for the reveal that is shown as the minimum reveal produced by cup distance C and door thickness in the table of minimum reveals. If a reveal is to be produced that is larger than this minimum reveal, select a mounting plate distance of the appropriate size.

Example: Determining distance from table

From the table, a door thickness = 20 mm and cup distance C = 4.5 mm produces a mounting-plate distance of 1.5 mm. This creates the required minimum reveal of, e.g., 1 mm. If a reveal of 2.5 mm is required instead, select a mounting-plate distance 1.5 mm larger. In this example, that means a distance of 3 mm instead of 1.5 mm.

Example: Using calculation formula to determine distance

Hinge for inset application, basis B = - 4 mm

Distance D = cup distance C + basis B + reveal F

Distance D = 4.5 mm - 4 mm + 1 mm = 1.5 mm

Intermediate values, which are not available as mounting-plate distances, are achieved by adjusting the hinge overlay.

Door thickness mm	Cup distance C mm					
	3,0	4,0	4,5	5,0	6,0	7,0
	Distance D mm					
15		0,2	0,7	1,2	2,2	3,2
16		0,3	0,8	1,3	2,3	3,3
17		0,4	0,9	1,4	2,4	3,4
18		0,6	1,1	1,6	2,6	3,5
19		0,8	1,3	1,8	2,7	3,7
20	0,1	1,0	1,5	2,0	3,0	3,9
21	0,4	1,3	1,8	2,3	3,2	4,2
22	1,2	1,8	2,2	2,6	3,6	4,5

Technical information

- ▶ Sensys
- ▶ Installation advice

Clip on hinge arm

Assembly

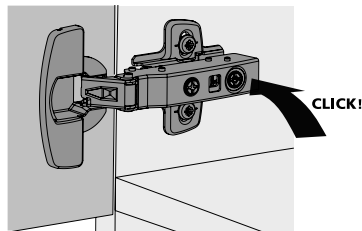
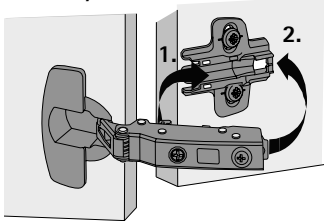

Removal

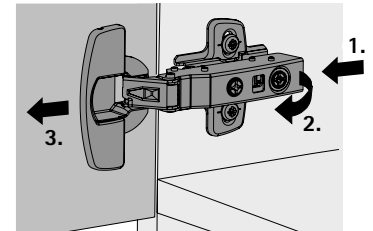

Adjustment

Overlay adjustment

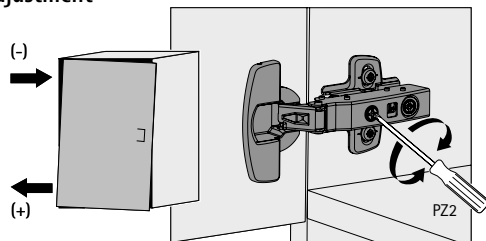

Depth adjustment (-) (+)

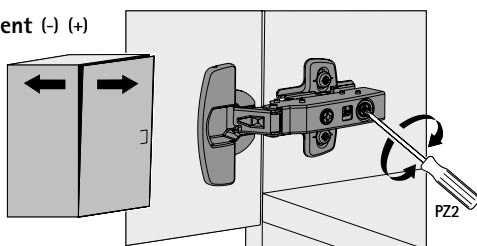

Height adjustment

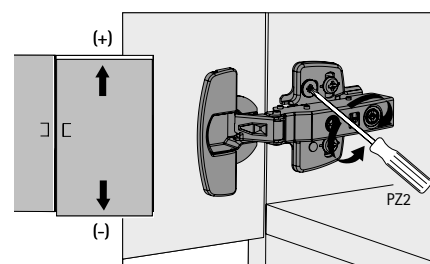
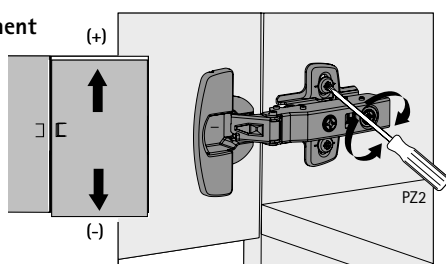

Screw on cup mounting method

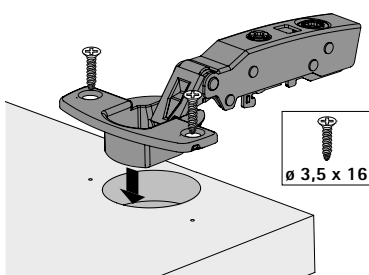

Technical information

- ▶ Sensys
- ▶ Installation advice

Press in cup mounting method

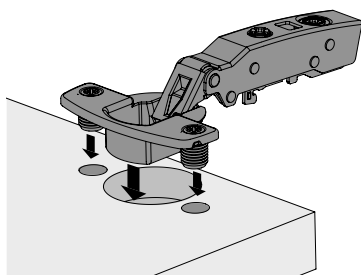

Flash fast installation method

Installation

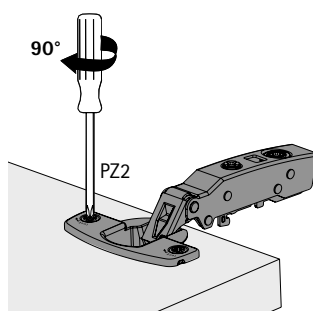
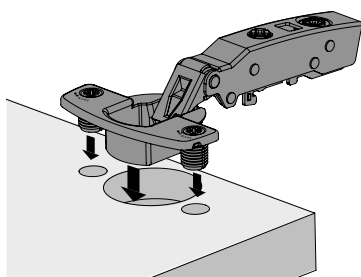

Removal

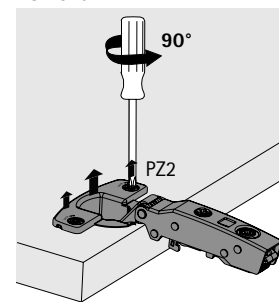

Fix tool-less fast assembly method

Installation

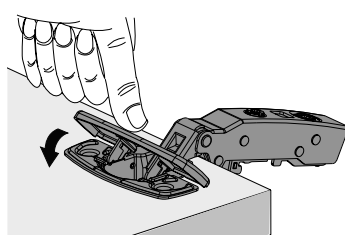
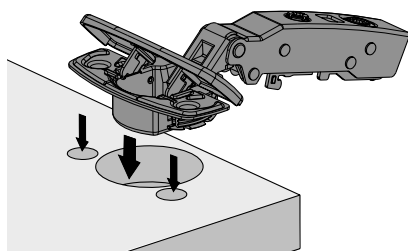

Removal

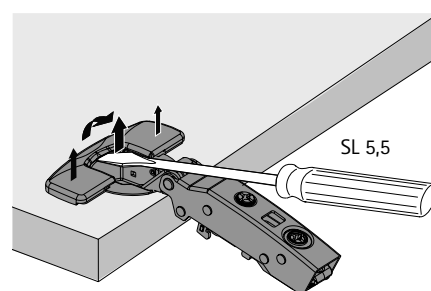

Premounted Euro screw installation method

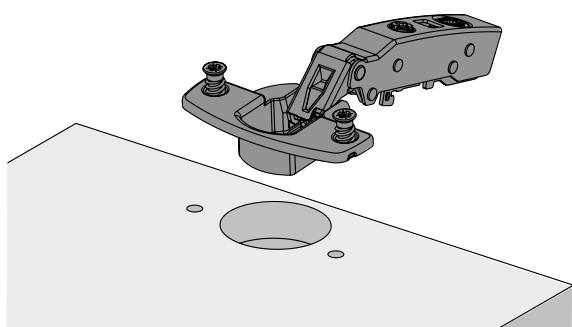

Technical information

- ▶ Sensys
- ▶ Installation advice

Using installation aid for mounting opening angle limiter for Sensys 8645i, 8639i W

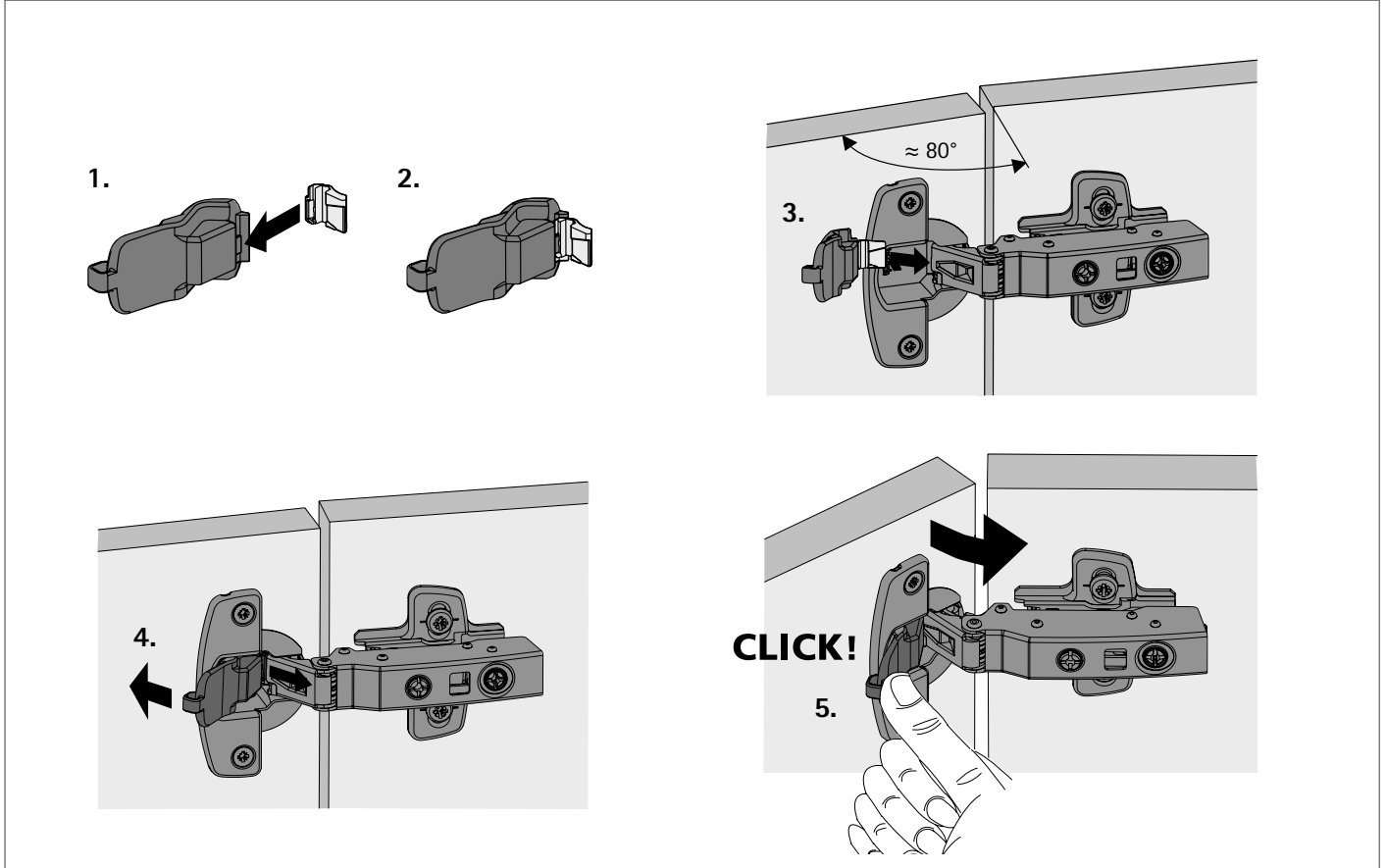

Using screwdriver for mounting opening angle limiter for Sensys 8645i, 8639i W

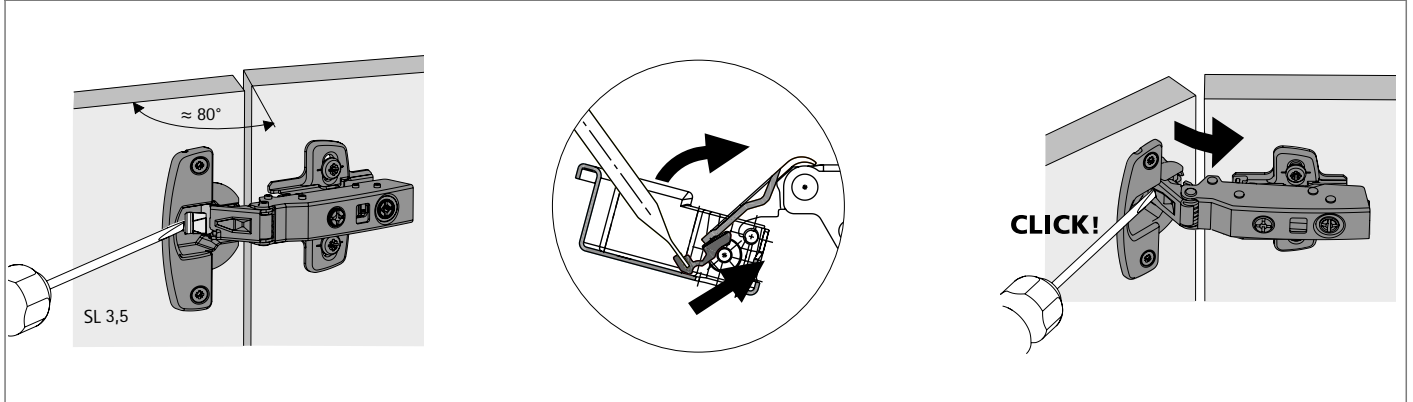

Mounting the opening angle limiter for Sensys 8638i aluminium framed doors

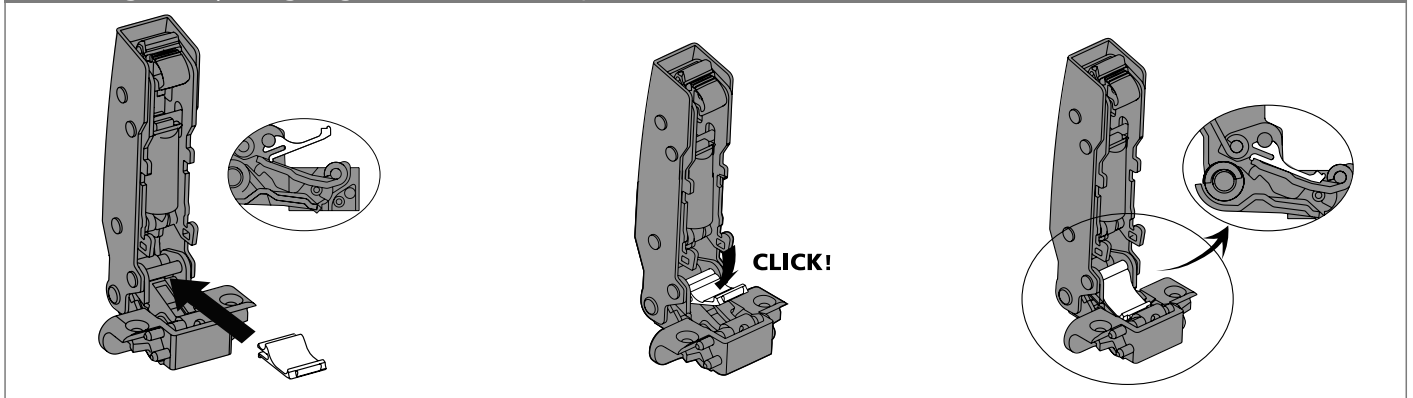

Technical information

- ▶ Sensys
- ▶ Installation advice

Mounting opening angle limiter for thick door hinge 8631i

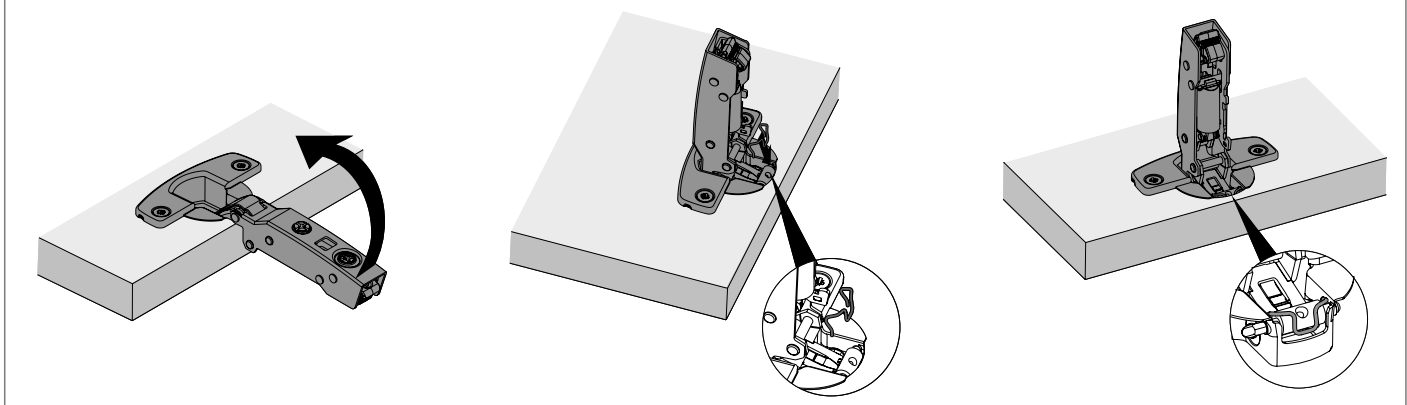

Mounting opening angle limiter for wide angle hinge 8657i

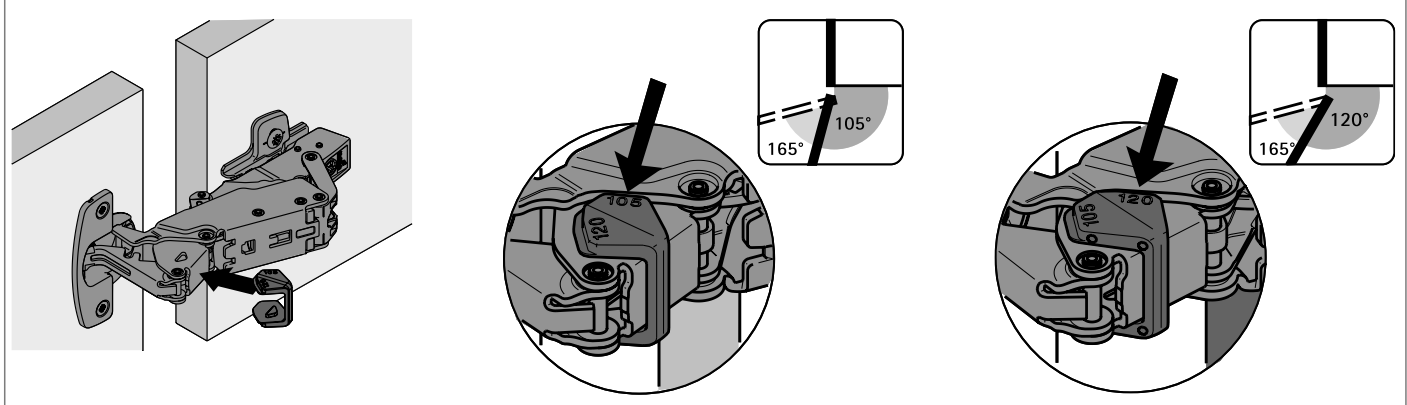

Quality criteria: concealed hinges

Quality that meets all the demands

The quality of hinges is subject to a process of continuous monitoring. Hettich fittings comply with the national and international quality standards of the markets our customers operate in. The diagrams below show examples of the principles behind some of the testing processes.

Application

Hettich hinges can be used in living room, kitchen, bathroom and office furniture both in the home and business environment.

Loading capacity

The quality levels indicated on products comply with the requirements of EN 15570 and satisfy the overload tests

at the specified level. We will be pleased to provide any further information you may require.

Corrosion test

Hettich hinges satisfy the corrosion requirements under EN ISO 9227-2012 in accordance with the 48 h neutral salt spray test (NSS) as well as DIN EN ISO 6270-2-2012 in accordance with the 96 h alternating condensation water climate test with alternating humidity and air temperature (AHT).

Quality assurance

The processes for assuring the quality of Hettich hinges are certified under EN ISO 9001, Cert. No. DE8000209.

Endurance test

The door is subjected to a specific number of opening and closing cycles.

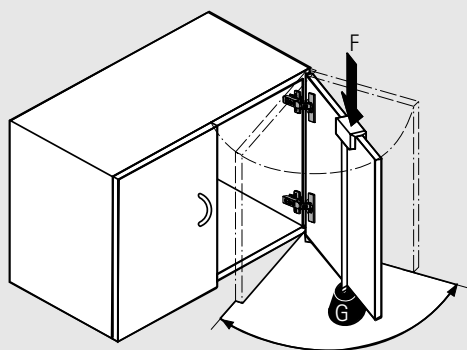

Closing test

The door is opened by 30° and pushed closed from this position by means of a pulley and falling weight.

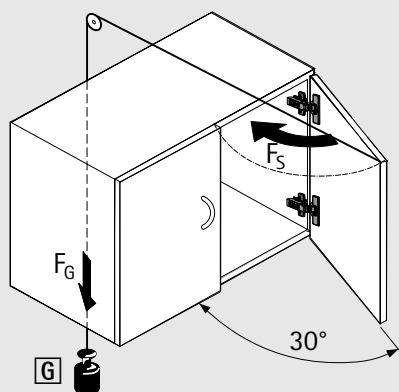

Horizontal test

The door is over opened with a defined test force F . (This test only applies to hinges with an opening angle $< 135^\circ$.)

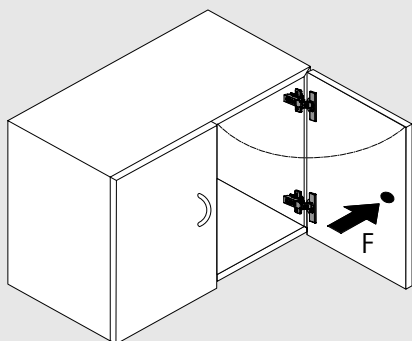

Vertical test

The door is subjected to a specific number of opening and closing cycles under a defined additional load G .

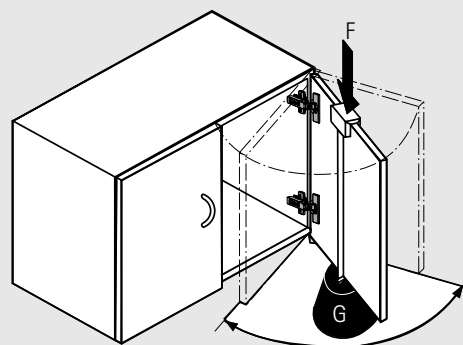

Hettich and the environment: committed to responsible practice, active protection, innovative thinking.

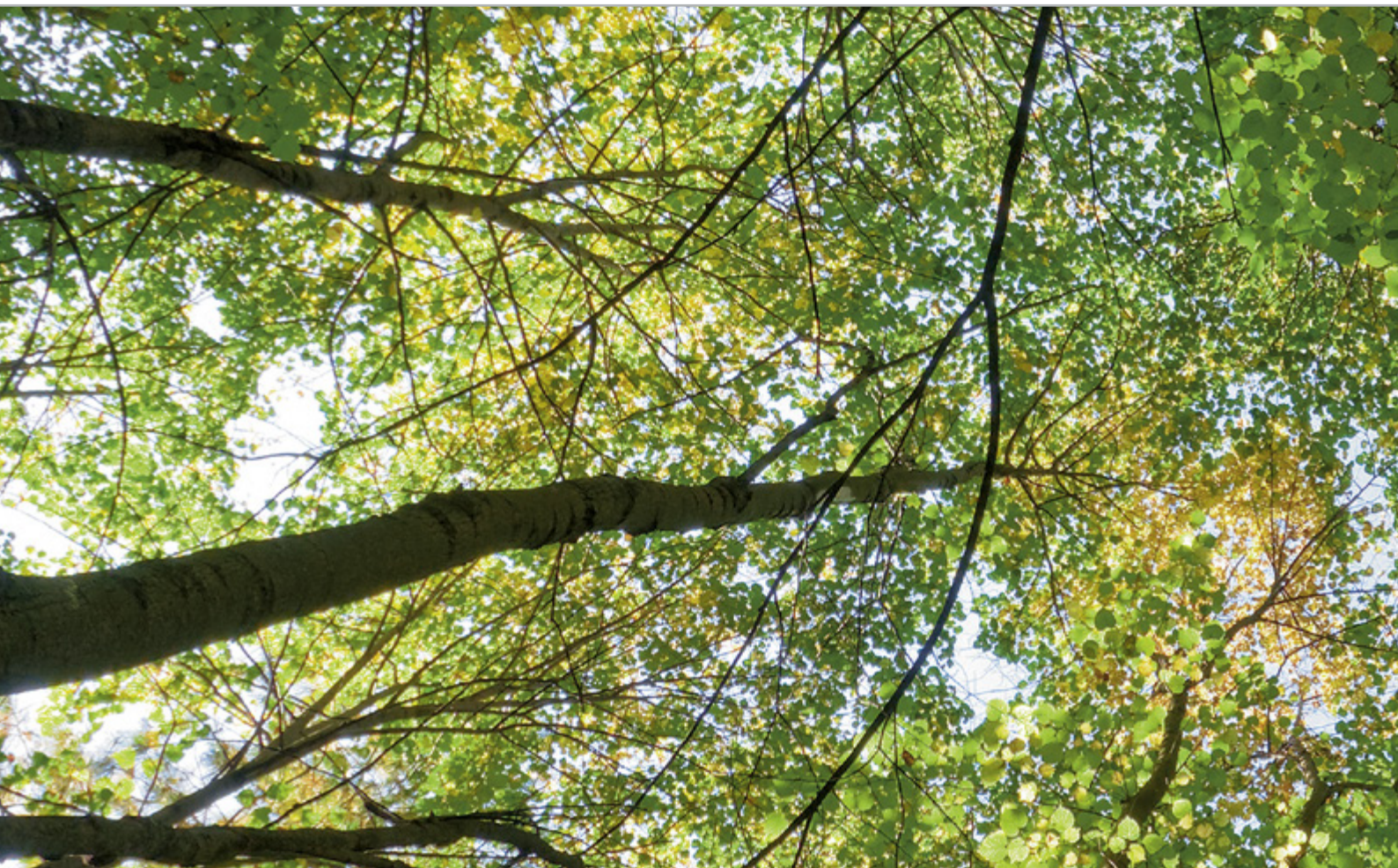

Hettich takes a responsibility for the world we live in. This awareness defines the strict policy of environmental management we practise. Our environmental officer has taken personal responsibility for these aspects throughout the group of companies over a period of many years. In addition, a separate environment committee has been established for each production site. We regard statutory provisions as minimum requirements. At significant sites we also implement the stringent EMAS Regulation. And we drive forward developments that in future will help to save even more raw materials and support the necessary endeavours towards sustainability.



Hettich environmental management

In 1996 Hettich started introducing effective environmental management systems under the stringent EMAS Regulation (currently: EC Regulation No. 761/2001, including EN ISO 14001/2004). This not only enables us to improve our environmental performance on a broad front but also achieve a high level of safety which, not least, also benefits our customers. This is why we also require our suppliers to meet the necessary minimum standards of environmental protection, industrial safety, health care and social welfare. The results achieved in the drawer-runner and drawer-system product segment at the Kirchlengern operation illustrate the impressive effects these measures have and verifiably demonstrate our tireless endeavours to translate words into action:

Relief to the environment between 1997 and 2008:

Specific water consumption:	56 per cent
Specific power consumption:	21 per cent
Specific heat consumption:	84 per cent
Specific CO ₂ emissions:	29 per cent



Hettich standard for product materials

Hettich underpins its commitment by applying an internal standard for product materials. This ensures that every product – from production to disposal – satisfies all environmental requirements. Hettich products are durable. Appropriately foresighted, our rigorous standards are formulated to ensure that international legislation is met as well. This provides a reliable basis for marketing furniture world-wide.



Zero-energy building – Hettich Forum

The Hettich Forum building with its neutral energy balance is a shining example of future-proof building design. Photovoltaic panels and solar collection system providing hot water as well as extensive roof greening and use of rain water underscore this building's overall sustainability concept in just the same way as the broad use of cellulose insulation material from recycled newspapers, highly efficient heat recovery and the bulb-free lighting concept do.

With the Hettich Group having acquired European Commission GreenBuilding Partner status on 5 March 2009, the comprehensive approach demonstrated by the Hettich Forum has also convinced the adjudicating panel of the national "Green Building Award 2009". Hettich received the first prize to be presented in the "New Building" category.

Technik für Möbel



www.hettich.com

1411-073_Sensys_0215_HUK/en

Technik für Möbel

