

# LC1x70-E-CC

## 1x70 W Constant Current LED driver

**70 W 220-240 VAC 50-60 Hz**

- Adjustable constant current output: 700 mA (default) - 1400 mA
- Protected up to 4 kV power network fast transients
- High efficiency, 0.91
- High power factor, 0.98
- Overload, open & short circuit protection
- Suitable for Class I, II or SELV luminaire
- External NTC thermal input
- Auxiliary 12 V output for cooling fan (not for independent use)
- Current setting resistor input
- Optional strain relief for independent use (LC1x70-SR)



### Connections

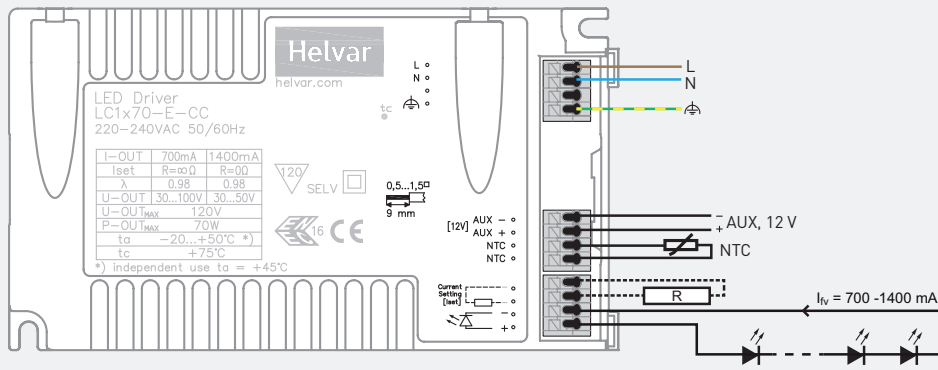

Current setting (p.2)	
Resistor R	output I <sub>v</sub>
open	700 mA
3.9kΩ	1050 mA
0 Ω	1400 mA

Note: Not suitable for load side switching operation.

### Mains Characteristics

Voltage range	198 - 264 VAC
DC range	176 - 280 VDC, starting voltage > 190 VDC
Max mains current at full load	0.31-0.39 A
Frequency	0 / 50 - 60 Hz
U-OUT <sub>max</sub> (abnormal)	120 V

### Load Output

Output current (I-OUT)	700 mA (default) - 1400 mA
Max output power	70 W
Auxiliary output *	12 V, ≤ 250 mA *

\* Not allowed to be used in independent use

Efficiency, at full load, typical 0.91

	700 mA	1400 mA
I-OUT	700 mA	1400 mA
P-out (max)	70 W	70 W
U-OUT	30 - 100 V	30 - 50 V
λ	0.98	0.98
η @ max	0.91	0.89

### Operating Conditions and Characteristics

Max.temperature at t <sub>c</sub> point	75 °C
Ambient temperature range	-20...+50 °C **
	(** Independent use t <sub>a</sub> max = +45 °C)
Storage temperature range	-40...+80 °C
Maximum relative humidity	no condensation
Life time (90 % survival rate)	50 000h, at TC max

### Connections and Mechanical Data

Wire size	0.5 - 1.5 mm <sup>2</sup>
Wire type	solid core and fine-stranded
Maximum driver to LED wire length	5m (1 m with NTC)
Weight	300 g (+25 g, strain relief LC1x70-SR)
Thermal sensor input	Input for external NTC thermal sensor
NTC trigger point	8.2 kΩ
IP rating	IP20

### Conformity & Standards

General and safety requirements	EN 61347-1
Particular safety requirements for d.c. or a.c. supplied electronic controlgear for LED modules, acc. to	EN 61347-2-13
Thermal protection class	EN61347, C5e
Mains current harmonics, acc. to	EN 61000-3-2
Limits for Voltage Fluctuations and Flicker, acc to	EN 61000-3-3
Radio Frequency Interference, acc. to	EN 55015
Immunity standard, acc. to	EN 61547
Performance requirements, acc to	EN 62384

Compliant with relevant EU directives  
ENEC, CE & SELV marked

Note: See page 2 for dimensions,

# Dimensions

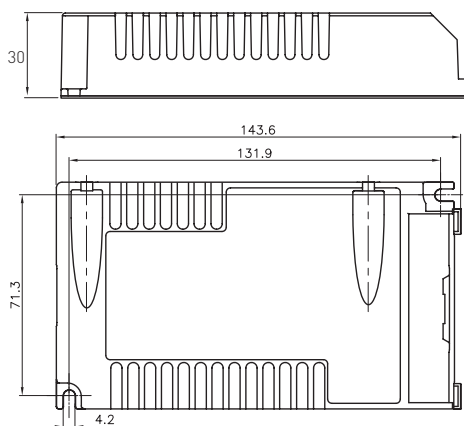

With strain relief (LC1x70-SR)

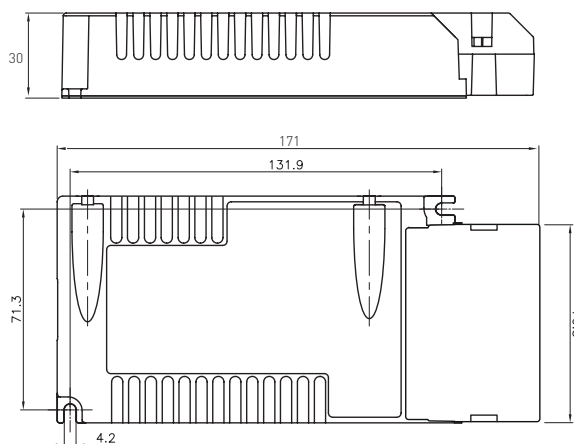

The LC1x70-E-CC LED driver is suited for either in-built and independent luminaire usage. In order to have safe and reliable LED driver operation, the LED luminaires will need to comply with the relevant standards and regulations (e.g. IEC/EN 60598-1). The LED luminaire shall be designed to adequately protect the LED driver from dust, moisture and pollution. The luminaire manufacturer is responsible for the correct choice and installation of the LED drivers according to the application and product datasheets. Specifications of the LED drivers may never exceed the operating conditions as per the product datasheets.

## Wiring considerations

### Wire type and cross section

- Please refer to datasheets connections & mechanical data

### Wiring insulation

- According to recommendations in EN 60598

### Maximum wire lengths

- Please refer to datasheets connections & mechanical data

### Wire connections

- Please refer to datasheets connections diagram

### Miniature Circuit Breakers (MCB)

- Type-C MCB's with trip characteristics in according to EN 60898 are recommended.

### LED driver earthing

- LED drivers are designed to support different luminaire classifications, like Class I or Class II fittings (no earth required). Please check the individual LED driver type for its exact safety class rating.
- For Helvar LED drivers to have a reliable operation and EMC performance, the luminaires are expected to have an earth connection.
- When using a SELV-rated LED driver, then the SELV driver output has to be insulated from the luminaire earth connection (ref. EN60598-1 luminaire standard).

## Installation & operational considerations

### Maximum tc temperature

- Reliable operation and lifetime is only guaranteed if the maximum tc point temperature is not exceeded under the conditions of use.

### Strain Relief for independent use

- The LC1x70-E-CC LED driver allow use both inside the luminaire and outside the luminaire, via the LC1x70-SR strain relief. The strain relief provides reliable fastening method for the mains and LED output wiring.
- Ensure that the LED driver does not exceed temperature higher than specified on the product datasheets.
- The general preferred installation position of LED drivers is to have the top cover facing upwards.

### Current setting resistor

The Helvar LC1x70 driver platform features an adjustable constant current output.

- An external resistor can be inserted in to the current setting terminal, allowing the user to adjust the LED driver output current.
- When no external resistor is connected, then the LED drivers will operate at their default lowest current level.
- A standard through-hole resistor can be used for the current setting. To achieve the most accurate output current it is recommended to select a quality low tolerance resistor.
- For the resistor / current value selection, please refer to the enclosed table below.

### Auxiliary output for cooling fan

LC1x70-E-CC driver features an auxiliary output for cooling fan

- Auxiliary output is not allowed to be used in independent installation
- In-built luminaire use: Check auxiliary maximum loading (cooling fan) by actual luminaire temperature measurements.

## Current setting resistor values

R (Ω)	0	1k	1.2K	1.5K	1.8K	2.2K	2.7K	3.3K	3.9K	4.7K	5.6K	6.8K	8.2K	10K	12K	15K	22K	27K	33K	39K	47K	56K	100K	150K	330K	1M
I <sub>out</sub> (mA)	1400	1260	1230	1190	1160	1130	1100	1070	1050	1020	980	950	920	890	860	830	800	790	780	770	750	740	720	715	710	700