

LC1x50-E-CC

1x50 W **Constant Current** LED driver

- Adjustable constant current output: 1050 (default) to 1400 mA
- Maximum 50 W load
- SELV < 60V output protection
- Overload, open & short circuit protection
- Accept DC mains in case of central emergency battery
- High efficiency 0.90
- Suitable for Class I, Class II and Class III luminaires
- Current setting resistor input
- Optional strain relief for independent use (LC1x70-SR)

50 W 220-240 VAC 50-60 Hz



Connections

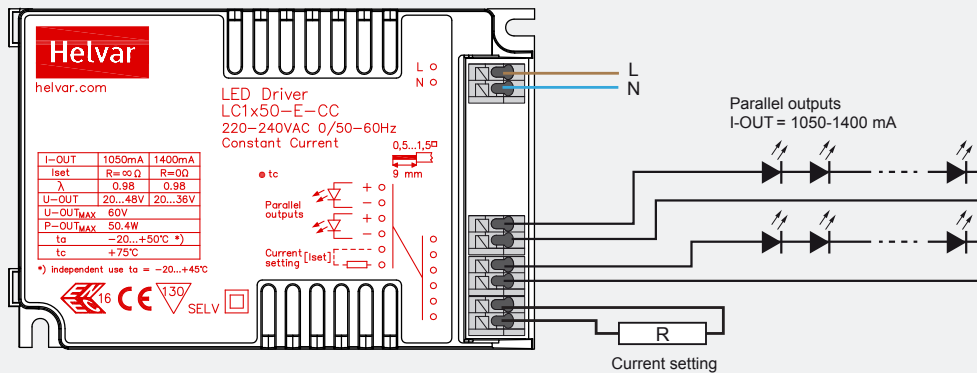

Current setting (p.2)	
Resistor R	output I _v
open	1050 mA
0 Ω	1400 mA

Note:

* Not suitable for load side switching operation.

Mains Characteristics

Voltage range	198-264 VAC,
DC range	176-280 VDC,
	starting voltage > 190 VDC
Max mains current at full load	0.23-0.30 A
Frequency	0 / 50 - 60 Hz
U-OUT _{max} (abnormal)	60 V

Load Output (SELV <60 V)

Output current (I-OUT)	1050 mA (default) - 1400 mA
Max output power	50.4 W
Efficiency, at full load, typical	0.90

	1050 mA	1400 mA
P-out (max)	50.4 W	50.4 W
U-OUT	20 - 48 V	20 - 36 V
λ	0.98	0.98
η @ max	0.90	0.88

Operating Conditions and Characteristics

Max.temperature at t _c point	75 °C
Ambient temperature range	-20...+50 °C, built-in use
	-20...+45 °C, independent use
Storage temperature range	-40...+80 °C
Maximum relative humidity	no condensation
Life time	50 000h, at TC max
	(90 % survival rate)

Connections and Mechanical Data

Wire size	0.5 - 1.5 mm ²
Wire type	solid core and fine-stranded
Maximum driver to LED wire length	5 m
Weight	180 g
	(+25 g, strain relief LC1x70-SR)
IP rating	IP20

Conformity

General and safety requirements	EN 61347-1
Particular safety requirements for d.c. or a.c. supplied electronic controlgear for LED modules, acc. to	EN 61347-2-13
Thermal protection class	EN61347, C5e
Mains current harmonics, acc. to	EN 61000-3-2
Limits for Voltage Fluctuations and Flicker, acc to	EN 61000-3-3
Radio Frequency Interference, acc. to	EN 55015
Immunity standard, acc. to	EN 61547
Performance requirements, acc to	EN 62384

Compliant with relevant EU directives
ENEC, CE and SELV marked

Note: See page 2 for dimensions

Dimensions

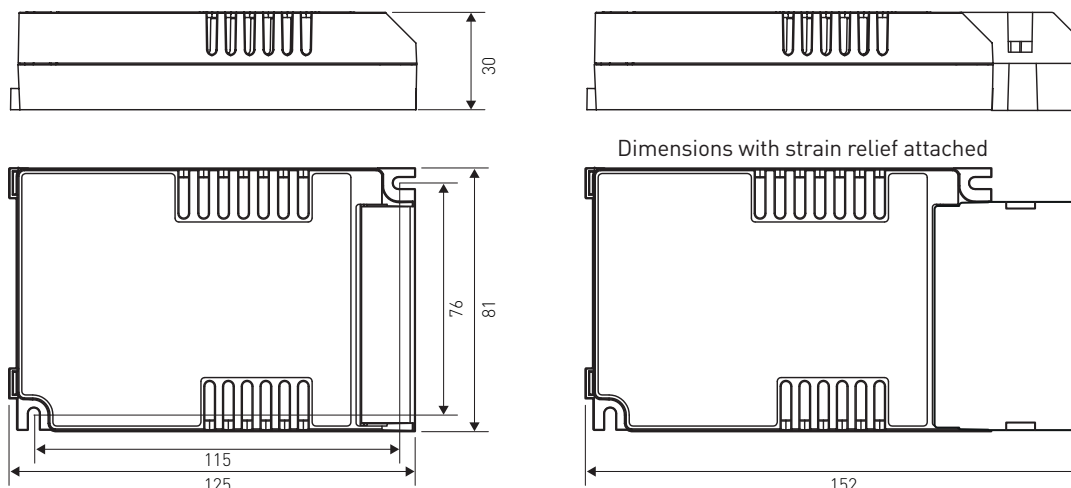

Wiring & connectivity

LC1x50-E-CC LED driver is suited for either in-built and independent luminaire usage. In order to have safe and reliable LED driver operation, the LED luminaires will need to comply with the relevant standards and regulations (e.g. IEC/EN 60598-1). The LED luminaire shall be designed to adequately protect the LED driver from dust, moisture and pollution. The luminaire manufacturer is responsible for the correct choice and installation of the LED drivers according to the application and product datasheets. Specifications of the LED drivers may never exceed the operating conditions as per the product datasheets.

Wiring considerations

Wire type and cross section

Please refer to datasheets connections & mechanical data

Wiring insulation

- According to recommendations in EN 60598

Maximum wire lengths

- Please refer to datasheets connections & mechanical data

Wire connections

- Please refer to datasheets connections diagram

Miniature Circuit Breakers (MCB)

- Type-C MCB's with trip characteristics in according to EN 60898 are recommended.

LED driver earthing

- LED drivers are designed to support different luminaire classifications, like Class I or Class II fittings (no earth required). Please check the individual LED driver type for its exact safety class rating.
- For Helvar LED drivers to have a reliable operation and EMC performance, the luminaires are expected to have an earth connection.

Installation & operational considerations

Maximum tc temperature

- Reliable operation and lifetime is only guaranteed if the maximum tc point temperature is not exceeded under the conditions of use.

Strain Relief for independent use

- LC1x50-E-CC LED driver allow use both inside the luminaire and outside the luminaire, via the LC1x70-SR strain relief. The strain relief provides reliable fastening method for the mains and LED output wiring.
- Ensure that the LED driver does not exceed temperature higher than specified on the product datasheets.

- The general preferred installation position of LED drivers is to have the top cover facing upwards.

Installation site

- Ensure that the LED driver does not exceed temperature higher than specified on the product datasheets.
- The general preferred installation position of LED drivers is to have the top cover facing upwards.

Current setting resistor

The Helvar LC1x50-E-CC LED driver feature an adjustable constant current output.

- An external resistor can be inserted in to the current setting terminal, allowing the user to adjust the LED driver output current.
- When no external resistor is connected, then the LED driver will operate at their default lowest current level (1050 mA).
- A standard through-hole resistor can be used for the current setting. To achieve the most accurate output current it is recommended to select a quality low tolerance resistor.
- For the resistor / current value selection, please refer to the enclosed table below.

Quantity of drivers per miniature circuit breaker 16 A Type C

Based on I_{cont} (pcs.)	Based on I_{peak} (pcs.)	Typ.inrush current I_{peak} (A)	1/2 value time Δt (μs)	Calculated energy $I_{peak}^2 \Delta t$ (A ² s)
43	57	29	156.0	0.1041

Current setting resistor values (Nominal Iout (±5 % tol.))

R (Ω)	0	1k	2k2	3k3	4k7	8k2	10k	15k	22k	33k	47k	68k	100k	220k	∞
I _{out} (mA)	1400	1380	1360	1340	1320	1290	1270	1240	1200	1170	1140	1120	1100	1070	1050