



## Havwoods Installation Guide: Glued Down Installations

These guidelines are designed to complement the current British Standard BS8201 or the relevant standards in the country of installation.

Safety must be paramount on every installation. All electrical equipment must be PAT tested and labelled and all cutting tools such as jigsaws, circular and bench saws must have guards fitted and cutting must be carried out on a suitable bench. You must also wear suitable work wear and remove or make safe any loose items such as jewellery. Safety is your responsibility.

The installer must be suitably trained and knowledgeable with wood flooring installations.

Engineered wood flooring can be installed as a floating floor, fully bonded or nailed. This document covers fully bonded installation. The following topics are covered by this document, for further information or for advice on any subject not covered here, please contact Havwoods:

### Environmental Conditions

### Subfloor Preparation

### Installation

### Underfloor Heating

### HVAC heating/climate control

### Floor Protection

*N.B: The final responsibility for the installation lies with the installer. It is the duty of the installer to inspect materials prior to installation and notify Havwoods of any potential material defects prior to installation. Installed materials are deemed to have been accepted.*

Havwoods International, Carnforth Business Park, Oakwood Way, Carnforth, Lancashire, LA5 9FD

Tel: +44 (0)1524 737 000

Fax: +44 (0)1524 737 001

Email: [info@havwoods.com](mailto:info@havwoods.com)

[www.havwoods.com](http://www.havwoods.com)

## ENVIRONMENTAL CONDITIONS

The building must be watertight with all windows and doors fitted and all wet trades complete before taking delivery of materials and before any wood flooring installation can take place.

Always check the ambient room temperature and humidity, which should be maintained at a constant level between 18°C (64°F) and 22°C (72°F) with a relative humidity between 45% - 65%RH prior to, during and for the whole life of the wood flooring. Try to avoid extremes of low or high temperatures as this will negatively affect the stability of the wood flooring.

Acclimatise the wood flooring in the room where the wood is to be fitted for at least 72 hours prior to the installation. The timber material should be maintained in their original packaging in this period. Only remove the materials from their packaging just before installation. The wood should be stored out of direct sunlight, away from walls and radiators and on battens fully supporting the wood to prevent a build of heat on the bottom boards.

Acclimatising is used to balance the wood flooring with the environment in the installation area.

If the temperature of the wood is at an equilibrium balance (the same as the room) and the moisture level of the wood is 8%(±2%) then you can assume that the timber does not require any further acclimatisation.

Keep the room temperature constant by using the heating set at minimum 15°C (59°F) or if there are problems with the permanent heating other forms of heating such as convector heaters can be used.

Do not use gas-type heaters as these will generate extra moisture in the air.

Infra-red type heaters do not generally warm the fabric of the room or the wood, they tend to only warm the person or item close to the heater.

Low humidity can cause the wood to shrink and high levels can cause expansion. Common causes of low humidity are using the heating at too high temperature, open fires and wood burners. High humidity is commonly caused by poor ventilation.

We recommend using a Digital Gauge, which can be purchased through Havwoods, to monitor the humidity and temperature level that can be easily adjusted by either placing moisture in the room (plants that are watered regularly or receptacles of water) or ventilating the room to reduce high levels of humidity. A humidifier/de-humidifier can also be used to control the atmosphere.

As a general rule, rooms/areas should be adequately ventilated to prevent a build of moisture in the environment. Care must also be given to rooms that are only heated when in use and with the heating switched fully off at other times. This can cause a build-up of humidity if the room is closed and not ventilated immediately after usage. The build of humidity / moisture will generally increase the moisture level of the wood flooring. The next time the room is used, the heating can dry out the moisture in the surface of the wood, causing cupping.

Wood will naturally change in size during seasonal variations in temperature and humidity.

During summer the humidity is generally at its highest level, hence the wood joins should be reasonably tight together. During the winter, when heating is commonly used, the humidity levels are generally lower and will produce small gaps between the joins. This occurrence is not a manufacturing or installation fault.

**Havwoods International, Carnforth Business Park, Oakwood Way, Carnforth, Lancashire, LA5 9FD**

**Tel: +44 (0)1524 737 000**

**Fax: +44 (0)1524 737 001**

**Email: [info@havwoods.com](mailto:info@havwoods.com)**

**[www.havwoods.com](http://www.havwoods.com)**

## SUBFLOOR PREPARATION

The subfloor must be sound, dry, free from contamination and flat to British Standard SR1 tolerance: maximum 3mm of level variance under a 2m long straight edge, at any point across the subfloor.

Where a wooden floor is to be installed using a glued down method, a structural substrate of adequate density must always be in place beneath the floor finishes. Please consult Havwoods if there is any question relating to substrate suitability.

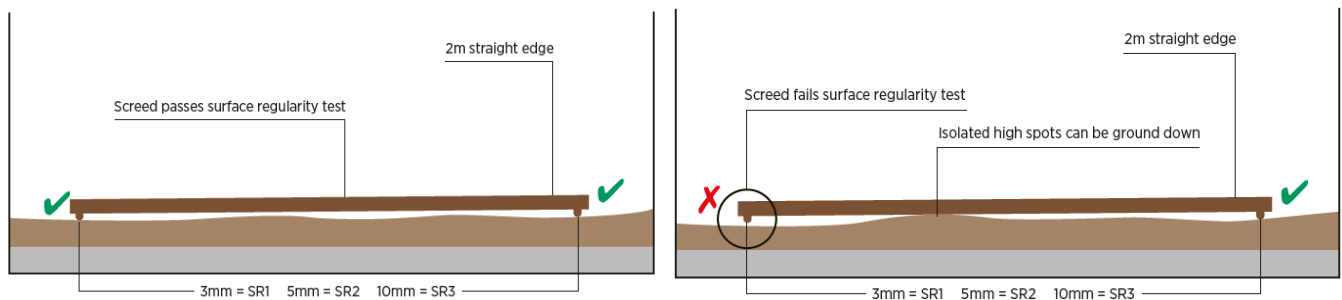

### Screeded Substrates

Cementitious (sand and cement) / Calcium Sulphate (Anhydrite):

The subfloor must be sound with no friable areas, free of laitance and dry. The moisture content of solid sub-floors must be checked in accordance with British Standards Annex A.

Moisture Testing is carried out using a Hygrometer set on top of the screed or by inserting a sleeve into the screed, (the sleeve method is not recommended with underfloor heating to avoid the risk of damage to the pipes).

For screed substrates, the moisture reading must be less than 65% Relative Humidity (RH) or (2.0%CM) for glued down installations.

Where there is a cementitious substrate, if the reading is above 65% RH and below 95% RH, we recommend using the Marldon MXS 140 two-part epoxy damp proof membrane (DPM). The DPM must be applied in accordance with the manufacturer's instructions. Marldon MXS 140 DPM (or any other epoxy DPM) cannot be used on anhydrite-type screeds.

A poured or pumped screed rarely achieves the required SR1 levels and it is recommended that a self-levelling compound be used prior to timber flooring installation. Self-levelling compounds also provide a more uniform surface for the best level of adhesion to the flooring.

If bonding directly to a screed, first prime the subfloor with an acrylic or polyurethane floor primer to ensure maximum bond strength and eliminate uneven drying of the adhesive due to varying substrate porosity. Havwoods recommend Marldon Universal Primer MXS120 for all screed types.

Structural movement joints in the concrete must be mirrored in the finished timber floor using a suitable flexible expansion detail.

*Note: For advice on the installation of Havwoods products over screeds with embedded or overlaid Underfloor Heating, please also see below section on Underfloor Heating.*

### Timber Substrates

The timber sub-floor must be sound, tested for vertical movement (which should be less than 5mm) and tested using a spike-type meter to ensure that they are dry. The moisture content of the subfloor should be less than 14% and within  $\pm 2\%$  of the wood floor being installed.

All suspended wood floors must have suitable through ventilation normally delivered by air bricks in the outside walls. Any wood sub-floor that has a higher moisture level than 14% should be investigated. They must also be free of infestations such as wood-rotting fungi and wood boring insects.

Solid timber floors bonded to a timber subfloor require a substrate of plywood in an equivalent or greater thickness than the solid flooring which is to be installed.

**Havwoods International, Carnforth Business Park, Oakwood Way, Carnforth, Lancashire, LA5 9FD**

**Tel: +44 (0)1524 737 000**

**Fax: +44 (0)1524 737 001**

**Email: [info@havwoods.com](mailto:info@havwoods.com)**

**[www.havwoods.com](http://www.havwoods.com)**

Suitable timber substrates for engineered floors are flooring-grade plywood and P5 flooring-grade particleboard. Timber substrates can be bonded to directly with a suitable MS Polymer adhesive (Havwoods recommend Marldon MXA200 adhesive), provided that they are sound, level to SR1 level requirements and free from contamination.

For existing suspended timber floors (where planks are securely fixed to joists/bearers), these can be over-boarded with flooring-grade plywood of a minimum 6mm thickness, fixed at 300mm centres, in a direction perpendicular to the run of the existing planks. Any loose sections of the existing planks must first be secured and any repairs to the existing bearers completed before over-plying may be considered.

Kingley bitumen paper can be sandwiched between the plywood and the wood sub-floor to reduce/prevent residual moisture affecting the wood flooring or adhesive.

*Note: For advice on the installation of Havwoods products over timber substrates with incorporated Underfloor Heating Pipes, please also see below section on Underfloor Heating.*

#### **Dry Screed Panels**

Structural or overlay dry screed flooring panels are generally suitable substrates for Havwoods timber flooring. All dry screed flooring panels should be primed with Marldon MXS120 Universal Primer before being fixed with Marldon MXA200 adhesive.

#### **Raised Access Floors**

Havwoods Floors may be bonded to new steel-encapsulated raised access floor panels using Marldon MXA200 adhesive. This is provided that any contaminants, such as oil residues from the manufacture of the panels, are removed prior to installation.

All access floors must have pedestals adjusted to remove any rocking action and be levelled, with pedestals locked in position, to best avoid the potential for deflection in the finished flooring. Access panels should be fixed to pedestals.

Existing raised access panels must be thoroughly cleaned and degreased with appropriate cleaning agents to remove any adhesive residues and other contaminants prior to direct installation of Havwoods timber flooring. If all existing contaminants can't be removed, then the access panels may be over-boarded with flooring-grade plywood of a minimum 6mm thickness, suitably fixed at centres of no wider than 300mm.

**Havwoods International, Carnforth Business Park, Oakwood Way, Carnforth, Lancashire, LA5 9FD**

**Tel: +44 (0)1524 737 000**

**Fax: +44 (0)1524 737 001**

**Email: [info@havwoods.com](mailto:info@havwoods.com)**

**[www.havwoods.com](http://www.havwoods.com)**

## INSTALLATION

The wood should be fully bonded to the prepared sub-floor using a suitable flexible adhesive. Havwoods recommend Marldon MXA200 MS polymer flexible adhesive.

This should be applied using a notched trowel (please see adhesive manufacturer's instructions for trowel notch size). Always lift an occasional board to see if there is at least an 80% coverage to the back of the board, if not then increase the notch size.

Be sure to install into wet adhesive and break the installation down into workable areas which can be installed within the open working time of the adhesive. If the adhesive is allowed to skin-over then it must be scraped from the subfloor and fresh adhesive laid.

Avoid standing or kneeling on elements which are sitting on wet adhesive as they may shift and result in gaps within the finished floor.

*Note: Do not use adhesive to level a sub-floor.*

In order to achieve a harmonious blend of tones throughout the floor, material should be taken from several packs and mixed during the installation. Working from 3-4 packs at a time creates a blend of tones from the variation in the raw material. Colour variety is inherent to all wooden floors and is a key feature in the choice of real wood material for any interior scheme.

It is also important to keep the atmosphere constant during and for at least 24 hours after the installation (particularly overnight) when temperatures can drop causing variations in the atmosphere and may not allow the glue to cure effectively in glued T&G installations.

Always create an unfilled perimeter expansion gap of a minimum 12mm on areas of less than 25 m<sup>2</sup> and a minimum of 15mm on larger areas.

Place spacers between the boards and the wall to keep the expansion gap whilst the adhesive is curing.

If the installation is over more than one day, strap or wedge the last row to prevent movement overnight. Weight (you will have packs of boards at this stage) down the last few rows to prevent them from lifting off the adhesive. If the boards do not close easily, you may need to use a knocking block or lever bar to assist in the placement. If you are installing a click system board fully bonded, locate the header join first at an angle and then lower the long join so that the short join is over the groove (longer protrusion). Once laid, use a knocking block or lever bar to knock the join into place.

Areas in excess of 10 linear meters x 8m width of the boards may require extra expansion between the boards and intermediate expansion in the length. Expansion gaps can be covered using a skirting board or beading/scotia.

Threshold profiles should be installed in all doorways, arches or narrow sections that lead from one room/area to the next. Perimeter details which do not allow for a skirting or scotia must have a threshold detail which covers the expansion gap.

In cases where these products cannot be used, an alternative is placing a low-density foam strip (low density meaning it can easily be crushed between your fingers) leaving it approximately 2mm below the height of the wood floor and then use a flexible acrylic mastic-type filler, or similar, to bridge over the foam.

All thresholds must allow for the required expansion and contraction. Door frames and architraves can be undercut to allow the wood to slide underneath, still allowing for the expansion.

*Note: Never undercut newel posts as these are structural sections of the stairs.*

### Specific to Plank Format Installations

Plank format flooring is designed to be installed in a randomly staggered pattern where the off-cut from the end of the previous row is used to start the following row. If another pattern is required for the project, then Havwoods must be consulted prior to order of the materials.

When planning the area, try to balance the board width against the two most prominent walls, considering focal points such as fireplaces. You must always try to have at least half a board at each opposing wall because smaller width boards are difficult to fit and may not give the adequate level of finish, particularly if the wall is not straight.

**Havwoods International, Carnforth Business Park, Oakwood Way, Carnforth, Lancashire, LA5 9FD**

**Tel: +44 (0)1524 737 000**

**Fax: +44 (0)1524 737 001**

**Email: [info@havwoods.com](mailto:info@havwoods.com)**

**[www.havwoods.com](http://www.havwoods.com)**

We recommend dry-laying the first two or three rows and adjusting the first row to the wall contours and adjusting for the width you have planned. Make sure you have at least a 300mm distance between header joins, ideally 500mm. Once done, mark a glue line on the sub-floor and move the boards whilst applying the adhesive. Immediately place the boards into the adhesive, which must be prior to the adhesive skinning over.

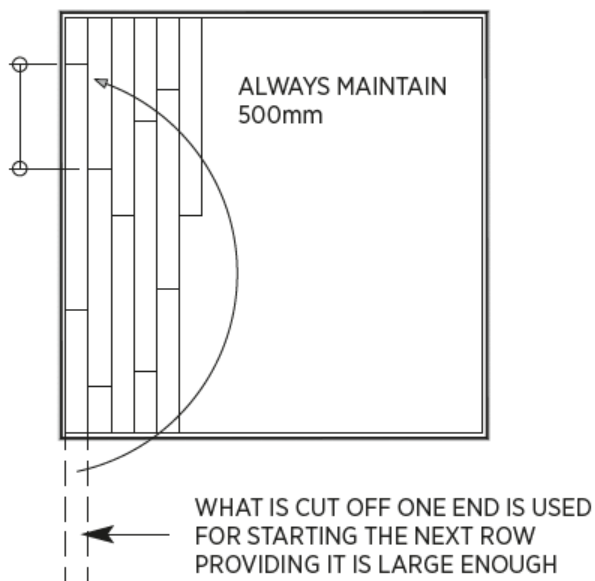

#### Specific to Patterned Installations

Patterned floors (such as herringbone and chevron formats) should be set out using a line of one run of left-hand and one run of right-hand blocks either side of a determined line from the centre of the room/area using a string or laser along the desired centre point of the installation. This is referred to as a crown line or row.

Herringbone patterned floors require that a section of left and right blocks is dry-laid prior to installation in order to establish the alignment of the blocks for the left- and right-hand elements. A working line is then drawn either side of the centre in order to keep the alignment of the herringbone pattern.

Crown rows must be left until the adhesive is fully cured before the remainder of the flooring installation may be completed.

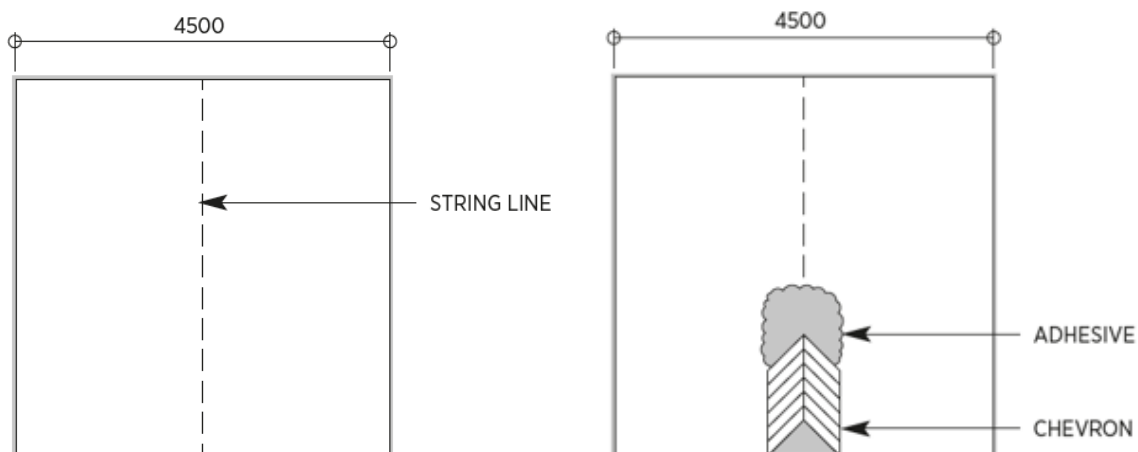

Havwoods International, Carnforth Business Park, Oakwood Way, Carnforth, Lancashire, LA5 9FD

Tel: +44 (0)1524 737 000

Fax: +44 (0)1524 737 001

Email: [info@havwoods.com](mailto:info@havwoods.com)

[www.havwoods.com](http://www.havwoods.com)

### Herringbone Working Lines:

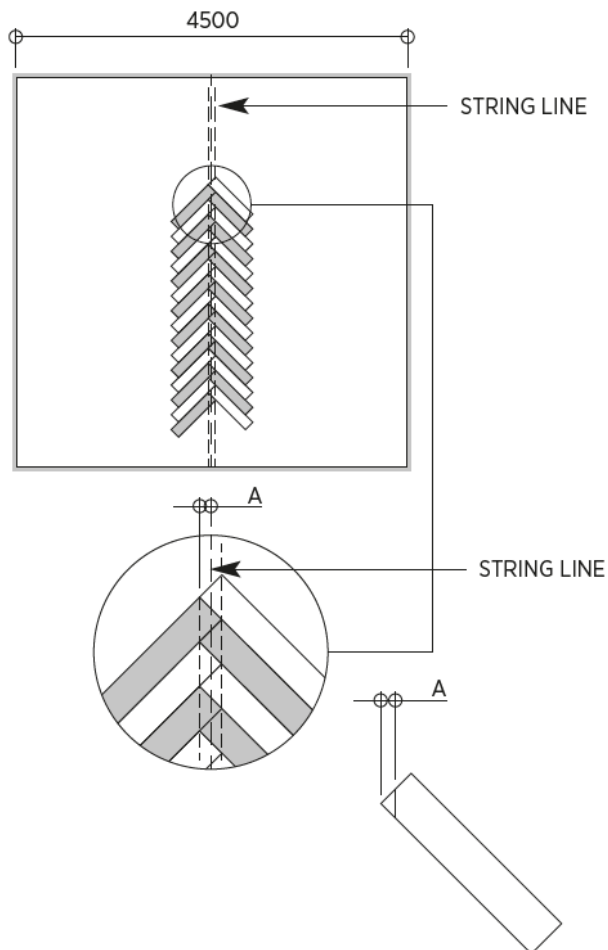

Where a border is to be installed to the perimeter of the pattern, draw the junction line of the pattern and border onto the subfloor. Glue up to but not over this line and continue the pattern installation over the line to the nearest full block. Once the adhesive is fully cured, use a plunge saw with a guide rail to cut along the junction line between pattern and border. Either route a complementary groove into the cut side of the pattern around the perimeter to receive the tongue of the border elements or use biscuit joints to form a join between the patterned field and the border.

### Border Installation:

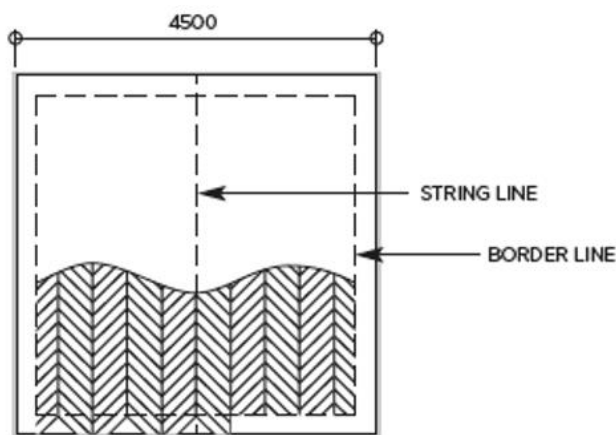

Havwoods International, Carnforth Business Park, Oakwood Way, Carnforth, Lancashire, LA5 9FD

Tel: +44 (0)1524 737 000

Fax: +44 (0)1524 737 001

Email: [info@havwoods.com](mailto:info@havwoods.com)

[www.havwoods.com](http://www.havwoods.com)

Versailles panel installations (and installations of other repeating elements) should be planned to ensure even cuts are present to all perimeter walls. Once the layout of the floor is established, either a crown row may be installed as above, or the installation can be brought outwards from a defined square corner. This does not need to be in the centre of the room and temporary battens may be fixed to the subfloor to allow the elements to remain aligned during installation if preferred.

Patterns which use elements of differing size and shape, such as mansion weave, should be dry-laid to define a central repeating line to be used as a crown row.

### **Underlays**

Where additional sound-dampening is required, bonded installations of wood flooring can be carried out over a high-density double-stuck underlay. Havwoods recommend the use of Stratabase cork-rubber resilient acoustic mat 3mm, 5mm, 10mm as the preferred method of incorporating a sound-reducing resilient layer. This underlay is bonded to the substrate with Marldon MXA200 adhesive, which must be allowed to fully cure prior to timber flooring installation. The timber flooring is then bonded to the Stratabase layer with the same Marldon MXA200 adhesive.

Gun-applied flexible adhesives (Such as Marldon MXA200 600ml sausages) may be used with slatted underlays to install in a glue batten method. The pre-cut reservoirs in the underlay are filled with adhesive at the manufacturer's designated coverage before floor placement. This installation method is only appropriate for plank formats.

Neither of the above underlay types offer a moisture vapour barrier or DPM. Where substrate moisture is measured at above 65%RH (approx. 2.0%CM), an appropriate moisture-suppressant primer or surface DPM must be installed prior to underlay or flooring installation.

*Note: For detailed installation advice and training on best practices, Havwoods Academy training courses are available. Please contact Havwoods for further information.*

**Havwoods International, Carnforth Business Park, Oakwood Way, Carnforth, Lancashire, LA5 9FD**

**Tel: +44 (0)1524 737 000**

**Fax: +44 (0)1524 737 001**

**Email: [info@havwoods.com](mailto:info@havwoods.com)**

**[www.havwoods.com](http://www.havwoods.com)**

## UNDERFLOOR HEATING (UFH)

We advise using a water pipe UFH systems that is set into a screed or electric type set into a smoothing compound under wood flooring.

Electric cable systems must have a minimum of 8mm coverage above the cables using a reinforced smoothing compound.

Heating elements (pipes or cables) should not be in direct contact with the reverse of the plank or the underlay. This is to avoid over-drying of the timber materials through direct transfer of heat into the wood. Electric mats or water pipes that are placed on top of screeds in routed panels must have a distribution board fitted above them to ensure an even heat distribution to the underside of the engineered board. This is typically a layer of plywood, particleboard or dry-screed panel. Aluminium spreader plates sit below pipes and do not offer separation of heating elements from the underside of the flooring.

Note: Some systems can create hot spots (when rugs or other items not on feet are placed directly onto the wood floor) which will negatively affect the stability of the wood flooring.

To ensure the surface of the wood flooring does not exceed 27°C (81°F), we recommend temperature probe(s) be installed within the subfloor build up to regulate the surface temperature. These should be located in each room / zone.

Note: Wall mounted, or free-standing thermostats placed >500 mm off the floor surface can allow higher temperatures at floor level.

### Embedded UFH Systems in Screeds

Prior to delivery, the underfloor heating must be commissioned and have been working for at least three weeks. Our advice is to gradually build up the UFH temperature to maximum for the first 5 days, run for 3-5 days and then allow the heating to cool gradually to the off position.

We would recommend carrying out at least two cycles to ensure any moisture is released. Once these cycles have been undertaken, switch off the heating and any artificial drying aids four days prior to setting and taking humidity readings. Never take humidity (or any other moisture tests) readings with the heating or other drying aids such as de- humidifiers on.

### UFH Systems Within or Beneath a Structural Deck

Unlike embedded water pipe subfloor heating systems, those heating systems situated within or beneath a structural deck are not generally commissioned prior to the installation of the floor coverings.

Where commissioning is to be undertaken with Havwoods flooring installed over this type of system, the below steps should be followed in order to prevent the occurrence of an excessive moisture and temperature gradient between the Havwoods timber flooring and the surrounding environment and/or substrate:

- All screeds situated beneath bearers should be tested for moisture to ensure that they do not have levels higher than 75%RH (2.5%CM)
- The environment should be tested and recorded to ensure that the environmental RH remains in the range of 45-65%.
- Floor protection must always be lifted prior to the commissioning process and should not be placed on the flooring at any stage while the heating system is in operation.
- Flow temperature should be set at the lowest possible setting and not above 30°C in the first instance.
- Temperature should be increased by a maximum of 2°C per day or 5°C every 3 days if the controls do not allow adjustments in 2°C increments.
- Surface temperature readings should be taken and recorded in the morning and evening of each day during the commissioning process to ensure that a surface temperature of 27°C is not exceeded in the flooring.
- 

Once the maximum flow temperature has been established to ensure surface temperatures are within permissible levels, tamper-proof controls should be implemented to ensure that this upper flow temperature is not exceeded.

Underfloor heating systems should be connected to a surface probe routed into the underside of the flooring or surface of the structural deck to give true surface readings. Those systems controlled by ambient thermostats generally offer an inadequate measure of control.

The care manual handed to the end user should highlight the requirement for heating systems to be increased gradually when moving into the colder months.

**Havwoods International, Carnforth Business Park, Oakwood Way, Carnforth, Lancashire, LA5 9FD**

**Tel: +44 (0)1524 737 000**

**Fax: +44 (0)1524 737 001**

**Email: [info@havwoods.com](mailto:info@havwoods.com)**

**[www.havwoods.com](http://www.havwoods.com)**

Information on the thermal conductivity/resistance of Havwoods products is available from Havwoods. Any information on the function of underfloor heating systems or exact calculations relating to thermal resistance or conductivity of the flooring build-up as a whole must be provided by the supplier of the heating system or the heating engineer.

The most critical time for the wood flooring is during and for 48 hours after the installation. Allowing the temperature or humidity to alter, particularly overnight when temperatures can drop, can cause excessive dimensional changes in the wood.

We recommend using alternative heat sources to the UFH during the installation period and that UFH systems should remain off for the installation period and for at least 48 hours after the installation. When bringing the UFH back into operation, increase the temperature by a maximum of 2°C (3.5°F) each 24-hour period until the normal room temperature is reached.

*Note: This also applies when using the UFH after periods of not being used. We would also recommend a cool down period using the same formula 2°C (3.5°F) each 24-hour period until switched off. Always set the heating to a frost temperature of minimum 12°C (54°F) when not in full usage.*

**Havwoods International, Carnforth Business Park, Oakwood Way, Carnforth, Lancashire, LA5 9FD**

**Tel: +44 (0)1524 737 000**

**Fax: +44 (0)1524 737 001**

**Email: [info@havwoods.com](mailto:info@havwoods.com)**

**[www.havwoods.com](http://www.havwoods.com)**

## COMMISSIONING & USAGE of HEATING, VENTILATION and AIR CONDITIONING (HVAC) SYSTEMS

This relates specifically to the transition from construction-phase environmental conditions to normal operating conditions where Havwoods timber floors are to be installed.

The concern relating to this project type is detailed in the expected Equilibrium Moisture Content (EMC) in the timber material as dictated by its environment:

### Construction-Phase Environment Example

Temperature: 15°C

Ambient Relative Humidity (RH): 60%

EMC: 11.14%

### Operational Environment Example

Temperature: 21°C

Ambient RH: 35%

EMC: 6.95%

Under the example transition above, the timber flooring will lose over 4% of moisture content once the environmental control system is brought into operation. This equates to ~1% of dimensional contraction (typical 0.22% dimensional change per 1% change in EMC). If this transition is made too quickly, the timber will be subjected to a high level of stress and this can result in surface cracking, gaps between timber elements, distortion of timber elements and other undesired actions.

Because of this, there is a requirement to bring the heating/ac system into operation slowly in order to allow staged-adaptation of the timber to the environment. This should be done as follows:

- Environmental conditions measured and recorded, and the temperature of the system set to that which is present in the environment at that time.
- The system should be allowed to operate at this temperature for at least 24 hours. RH should be monitored and recorded in the environment in this time.
- No more than 2°C increase in the system per 24-hour period with recordings to be made of RH.
- System brought up to operating temperature with each stage recorded and documented over several days with RH to also be recorded.
- An environmental measure should be in place (such as a LogTag temperature and humidity device) to monitor RH and provide an alert when RH levels fall below 35% so that plants or other moisture sources may be introduced.

The optimum performance of the timber flooring will remain between 40-60% RH and between 18-22°C due to the 8% (±2%) moisture content at the time of manufacture. The above process is designed to prevent failure of the timber flooring under sudden exposure to altered environmental conditions. BS8201:2011 states that acceptable seasonal gapping can be expected.

Requirements for temporary heating (during the installation at construction phase) in colder months to be operational 24 hours a day remain. All efforts should be made to achieve temperatures of 18°C at the time of timber flooring installation and until the project completion. If RH levels are found to be above 65% at the time of installation, works should be postponed until ventilation and/or dehumidifiers have been introduced in order to provide suitable installation conditions.

**Havwoods International, Carnforth Business Park, Oakwood Way, Carnforth, Lancashire, LA5 9FD**

**Tel: +44 (0)1524 737 000**

**Fax: +44 (0)1524 737 001**

**Email: [info@havwoods.com](mailto:info@havwoods.com)**

**[www.havwoods.com](http://www.havwoods.com)**

## FLOOR PROTECTION

When Havwoods floors are installed in a construction environment, they should be adequately protected in order to prevent damage from any following trades.

Havwoods recommend that a layer of building paper or another suitable breathable membrane is first installed prior to an impact protection layer. The building paper should be installed over the whole floor area and overlapped at joins before being taped on the surface, ensuring not to tape the protection to the wood floor surface. An impact protection layer of fire-retardant hardboard can then be installed over the building paper, leaving the hardboard 50-100mm short of the perimeter to allow ventilation of moisture.

Caution should be taken if using corrugated plastic floor protection (i.e. Corex) because this is non-permeable to moisture and can cause construction moisture to be trapped in the timber, leading to excessive expansion or telegraphing of the floor surface. If this type of protection must be used, always install a layer of overlapped building paper (or another suitable breathable layer) first and ensure Corex is not left on the floor for any extended period.

Any floor protection should be lifted regularly, ideally every 2-3 weeks, to allow ventilation to the floor on projects with elongated periods between flooring installation and project completion.

Never tape flooring protection directly to the flooring surface because tape adhesive can cause irreparable damage to the floor finish. Overlap paper layer and tape sheets to one another and/or walls and tape impact protection to the paper layer.

Never run underfloor heating systems while floor protection is in place because the protection layers can trap moisture or generate elevated surface temperatures, potentially leading to problems such as excessive expansion or over-drying and shrinkage of the wood material respectively.

*©This information Sheet was written by Havwoods International, Carnforth Business Park, Oakwood Way, Carnforth, Lancashire, LA5 9FD.*

*At the time of writing and publication of this sheet, all information is specified correctly. The photographs used in this sheet are intended only as illustrations. No rights can be derived from them.*

07/01/2020

**Havwoods International, Carnforth Business Park, Oakwood Way, Carnforth, Lancashire, LA5 9FD**

**Tel: +44 (0)1524 737 000**

**Fax: +44 (0)1524 737 001**

**Email: [info@havwoods.com](mailto:info@havwoods.com)**

**[www.havwoods.com](http://www.havwoods.com)**