

# Fig. 953 & 953G Ductile Iron with Double Regulating Feature



## FEATURES & BENEFITS

- Robust iron body materials for long service life
- Precise flow regulation
- Flanged with handwheel – easy to install and operate
- Positive flow control at all handwheel settings



## MATERIAL SPECIFICATION

Component	Material	Specification	
		BS EN	ASTM
Body	Ductile Iron	-	-
Shaft	Stainless Steel	10088-1 X17CrNi16-2	AISI 431
Disc	Aluminium Bronze	1982 CC333G	B148 C95800
Disc	Stainless Steel	10270 X10CrNr18-8	A276 304
Liner	EPDM	-	-
Bearings	PTFE Coated Steel	-	-

## PRESSURE/TEMPERATURE RATING

EPDM Seat  
16 bar from -10 up to 120°C

## SERVICE RATING

Suitable for Chilled Water, LTHW and MTHW

## TEST PRESSURES

Shell: 24 bar  
Seat: 17.6 bar

## SPECIFICATION

Valves up to and including 200mm can be supplied lever operated or fully enclosed gear operated.

All operators fitted with double regulating feature.

Flow charts available.

## NOTE

Butterfly valves should not be less than 30° open when used for regulation duties.

## DIMENSIONAL DRAWINGS

Fig. 953

Nom Size	mm	50	65	80	100	125	150	200
A	mm	195	207	213	232	245	257	305
B	mm	83	95	102	124	136	150	197
C	mm	44	48	48	54	57	57	63
D	mm	32	32	32	32	32	32	44
E	mm	102	121	130	171	197	219	268
F	mm	260	260	260	260	260	260	356
G	mm	32	46	64	90	111	145	193
Weight	kg	3.5	4	5.4	6.7	9	9.9	16.4

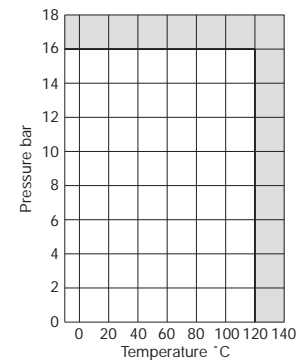
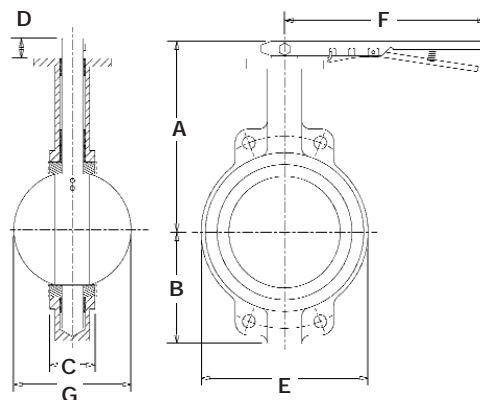
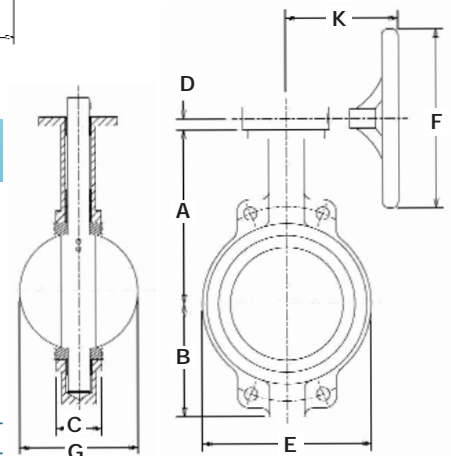

Fig. 953G

Nom Size	mm	50	65	80	100	125	150	200	250	300	350	400	450	500	600
A	mm	162	175	181	200	213	225	260	292	337	368	400	422	479	562
B	mm	83	95	102	124	136	150	197	210	248	279	305	381	381	457
C	mm	44	48	48	54	57	57	63	70	79	79	89	108	133	156
D	mm	42	42	42	42	42	42	40	40	40	40	-	-	-	-
E	mm	102	121	130	171	197	219	268	332	410	435	508	543	592	708
F	mm	150	150	150	150	300	300	300	300	300	300	450	450	450	450
G	mm	32	46	64	90	111	145	193	241	290	325	380	427	474	574
K	mm	240	240	240	240	240	240	230	230	230	230	277	277	321	335
Weight	kg	15	15.5	16.9	18.2	20.5	21.4	29	33.5	45.8	56.2	88.4	110.2	160.5	260



For Commissioning Valve Coefficients please refer to pages 45-47.

Every effort has been made to ensure that the information contained in this publication is accurate at the time of publishing. Hattersley Ltd assumes no responsibility or liability for typographical errors or omissions or for any misinterpretation of the information within the publication and reserves the right to change without notice.