

Fig. 950W & 950WG Semi-lugged Wafer Pattern



FEATURES & BENEFITS

- Ductile Iron Body
- Aluminium Bronze Disc
- Liner bonded to steel backing ring
- High strength, low friction bearings for upper and lower shafts, to restrain shaft deflection and ensure effective stem sealing
- Long neck for insulation
- Maintenance free



MATERIAL SPECIFICATION

Component	Material	Specification	
		BS EN	ASTM
Body	Ductile Iron	1563 EN-JS 1030	A536 65-45-12
Shaft	Stainless Steel	10088-1 X5CrNiMo17-12-2	A532 Gr316
Disc	Bronze	1982 CC333G	B148-C95300
Bushes (up to 100mm)	PTFE	-	-
125mm and above	Bronze (lubricated)	-	-
O-Ring	Buna N	-	-
Liner	EPDM	-	-

PRESSURE/TEMPERATURE RATING

PN16 from -10 to 85°C (WRAS)
PN16 from -10 to 120°C (NON-WRAS)

TEST PRESSURES

Each valve is individually hydrostatically tested to BS EN 12266-1 at the following test pressures.

Shell: 24 bar
Seat: 17.6 bar

SPECIFICATION

Conforms to BS EN 593:2009.

Semi-lugged.

Aluminium bronze or stainless steel disc.

WRAS Approved.

Lever or gearbox.

Valves DN250 and larger supplied as standard with fully enclosed gear operator.

Valves may be used for flow regulation.

DIMENSIONS & WEIGHTS

Fig. 950W

Nom Size	mm	50	65	80	100	125	150	200
A	mm	195	207	213	232	245	257	305
B	mm	83	95	102	124	136	150	197
C	mm	44	48	48	54	57	57	63
D	mm	32	32	32	32	32	32	44
E	mm	102	121	130	171	197	219	268
F	mm	260	260	260	260	260	260	356
G	mm	32	46	64	90	111	145	193
Weight	kg	3.5	4	5.4	6.7	9	9.9	16.4

Fig. 950WG

Nom Size	mm	50	65	80	100	125	150	200	250	300
A	mm	162	175	181	200	213	225	260	292	337
B	mm	83	95	102	124	136	150	197	210	248
C	mm	44	48	48	54	57	57	63	70	79
D	mm	42	42	42	42	42	42	40	40	40
E	mm	102	121	130	171	197	219	268	332	410
F	mm	150	150	150	150	300	300	300	300	300
G	mm	32	46	64	90	111	145	193	241	290
K	mm	240	240	240	240	240	240	230	230	230
Weight	kg	15	15.5	16.9	18.2	20.5	21.4	29	33.5	45.8

DIMENSIONAL DRAWINGS

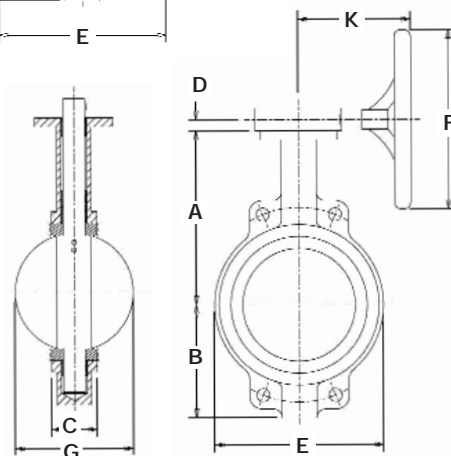
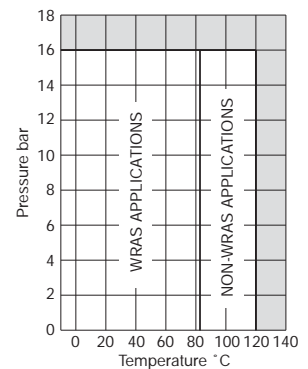
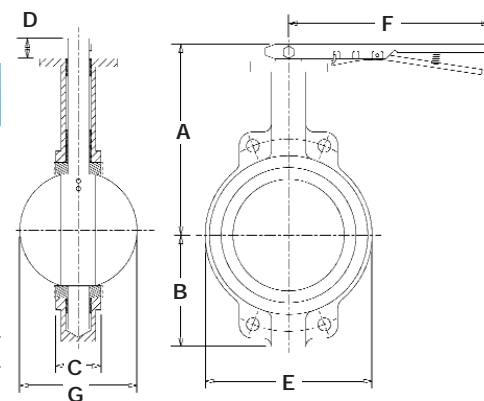

Every effort has been made to ensure that the information contained in this publication is accurate at the time of publishing. Hattersley Ltd assumes no responsibility or liability for typographical errors or omissions or for any misinterpretation of the information within the publication and reserves the right to change without notice.