

Fig. 907
Bronze Y-Type



FEATURES & BENEFITS

- Eliminate the problems caused by foreign matter within piping systems
- Perforated stainless steel screen with robust design, low flow resistance and high quality materials
- WRAS approved for use on hot and cold water systems up to 85°C
- 0.75mm screen perforations
- Supplied with two fig. 631 test points to measure the pressure drop across the strainer

MATERIAL SPECIFICATION

Component	Material	Specification BS EN
Body	Bronze	BS EN 1982 CC491K
Cap	Bronze	BS EN 1982 CC491K
Strainer Mesh	Stainless Steel	Type 304
Gasket	Klingsil	C4430
ID Plate	Anodised Aluminium	
Test Point (Fig.631)	DZR Brass	BS EN 12165 CW602N



PRESSURE/TEMPERATURE RATING

25 bar from -10 to 120°C

END CONNECTION

UK: TAPER THREADED TO BS EN 10226-2
US: ANSI B1.20.1

SPECIFICATION

Strainers fitted with stainless steel perforated strainer element with 0.75mm diameter holes.

Screens fitted into Hattersley Strainers and workmanship associated with all Hattersley products.

This strainer is not suitable for use on group 1 gases, group 2 gases or unstable fluids, as defined by the Pressure Equipment Directive 97/23/EC.

DIMENSIONS & WEIGHTS

Size (in)	A (mm)	B (mm)	C (mm)	D (mm)	E (mm)	F (mm)	G (mm)	H (mm)	Weight (kg)
1/2	71	29	42	49	100	27	35	144	0.27
3/4	86	35	51	60	114	33	44	176	0.44
1	101	45	55	67	127	42	54	202	0.78
1 1/4	134	54	80	93	157	50	63	294	1.30
1 1/2	148	63	87	103	171	58	73	322	1.81
2	176	77	97	119	194	71	93	367	3.10

DIMENSIONAL DRAWINGS

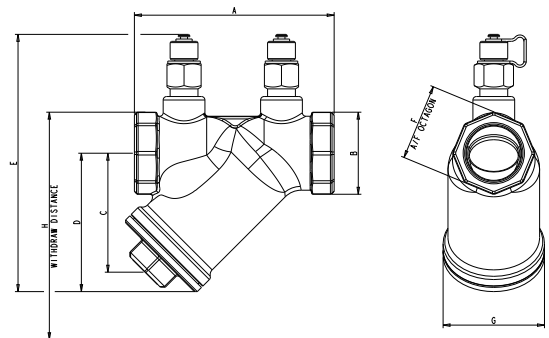

PRESSURE/TEMPERATURE RATING

Temperature °C	-10 to 100	110	120
Pressure bar	25	23.4	21.8

Every effort has been made to ensure that the information contained in this publication is accurate at the time of publishing. Hattersley Ltd assumes no responsibility or liability for typographical errors or omissions or for any misinterpretation of the information within the publication and reserves the right to change without notice.

1213_1/4